



(86) Date de dépôt PCT/PCT Filing Date: 2002/03/27
 (87) Date publication PCT/PCT Publication Date: 2002/10/10
 (45) Date de délivrance/Issue Date: 2009/08/11
 (85) Entrée phase nationale/National Entry: 2003/09/26
 (86) N° demande PCT/PCT Application No.: US 2002/009775
 (87) N° publication PCT/PCT Publication No.: 2002/078549
 (30) Priorité/Priority: 2001/03/28 (US60/279,477)

(51) Cl.Int./Int.Cl. *A61B 17/122* (2006.01),
A61B 8/06 (2006.01), *A61B 17/00* (2006.01),
A61B 17/128 (2006.01), *A61B 17/42* (2006.01),
A61B 5/026 (2006.01)

(72) Inventeurs/Inventors:
 BURBANK, FRED H., US;
 JONES, MIKE, US;
 SERRA, R. J., US;
 ALTIERI, GREIG, US;
 UYENO, JILL, US;
 WONG, YU-TUNG, US;
 WERNETH, RANDY, US

(73) Propriétaire/Owner:

(54) Titre : PROCÉDE ET APPAREIL POUR DETECTER ET LIGATURER DES ARTERES UTERINES
 (54) Title: METHOD AND APPARATUS FOR THE DETECTION AND LIGATION OF UTERINE ARTERIES

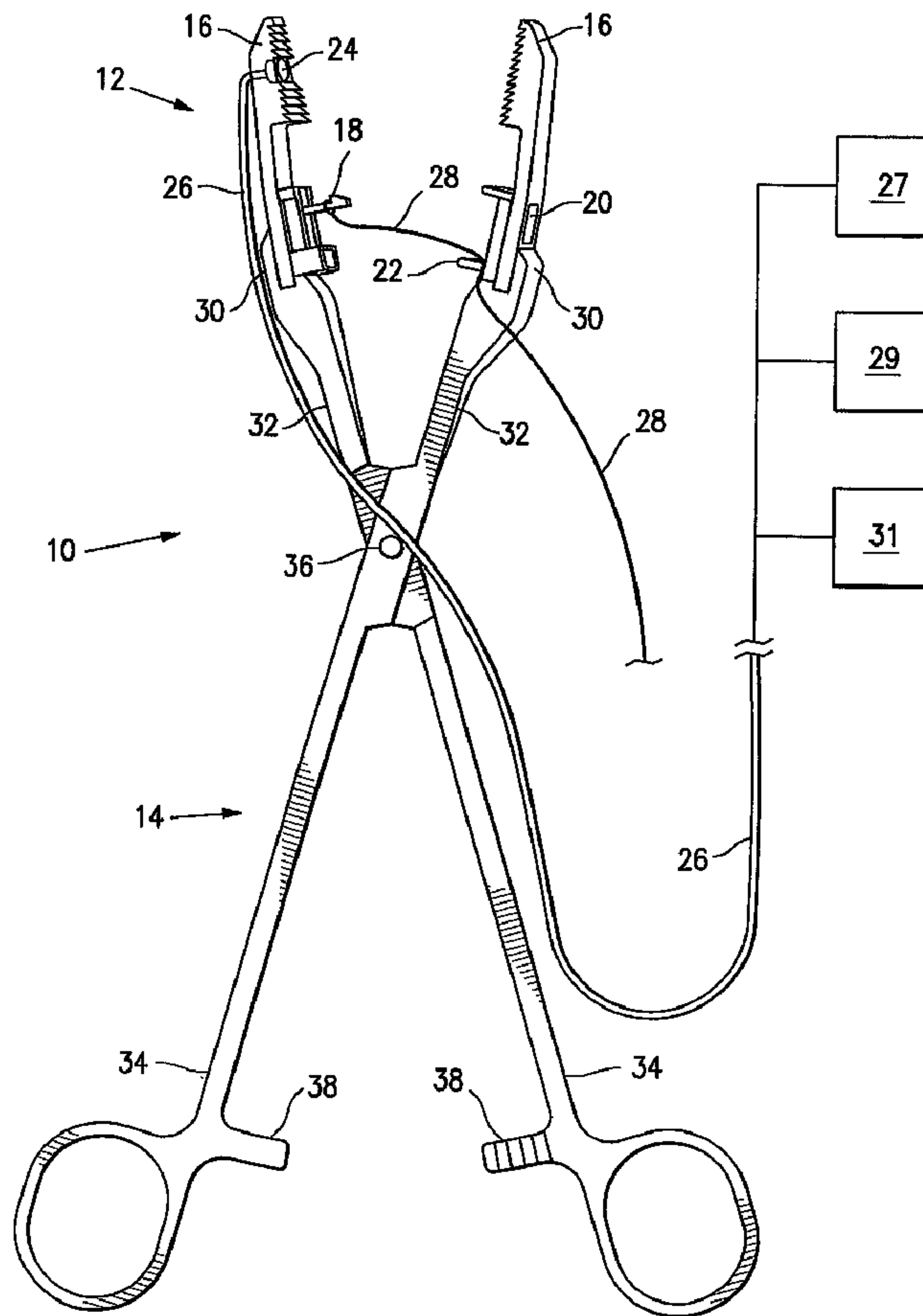

(57) Abrégé/Abstract:

The invention provides devices, systems and methods for occluding arteries without puncturing skin or vessel walls. The devices, systems and methods for occluding arteries are configured to be applied to arteries externally of the arteries. Occlusion may be

(73) Propriétaires(suite)/Owners(continued):VASCULAR CONTROL SYSTEMS, INC., US

(74) Agent: DENNISON ASSOCIATES

(57) Abrégé(suite)/Abstract(continued):

temporary or permanent, and may be partial or complete. Clamping a device to tissue near to an artery is effective to compress tissue around the artery and to indirectly compress the artery. The methods, devices and systems of the invention find use in, for example, treatment of uterine disorders and conditions which may be treated by occlusion of the uterine arteries. A uterine artery may be access via a patient's vagina by compressing a portion of the vaginal wall around a portion of a uterine artery to occlude a uterine artery. Clamping of an artery may also be performed by clamping a device directly onto an artery.

(12) INTERNATIONAL APPLICATION PUBLISHED UNDER THE PATENT COOPERATION TREATY (PCT)

(19) World Intellectual Property Organization
International Bureau(43) International Publication Date
10 October 2002 (10.10.2002)

PCT

(10) International Publication Number
WO 02/078549 A3(51) International Patent Classification⁷: **A61B 17/122**

(21) International Application Number: PCT/US02/09775

(22) International Filing Date: 27 March 2002 (27.03.2002)

(25) Filing Language: English

(26) Publication Language: English

(30) Priority Data:
60/279,477 28 March 2001 (28.03.2001) US(71) Applicant (for all designated States except US): **VASCULAR CONTROL SYSTEMS, INC.** [US/US]; 32236-E Paseo Adelanto, San Juan Capistrano, CA 92675 (US).

(72) Inventors; and

(75) Inventors/Applicants (for US only): **BURBANK, Fred,****H.** [US/US]; 12 Old Ranch Road, Laguna Niguel, CA 92677 (US). **JONES, Mike** [US/US]; 34441 Camino El Malino, Capistrano Beach, CA 92624 (US). **SERRA, R., J.** [US/US]; 17 Misty Meadow, Irvine, CA 92612 (US). **ALTIERI, Greig** [US/US]; 1102 Temple Hills Drive, Laguna Beach, CA 92977 (US). **UYENO, Jill** [US/US]; 27550 Hillcrest #4Q, Mission Viejo, CA 92691 (US). **WONG, Yu-Tung** [US/US]; 16891 Bolero Lane, Huntington Beach, CA 92649 (US). **WERNETH, Randy** [US/US]; 13422 Little Dawn Lane, Poway, CA 92064 (US).(74) Agent: **LYNCH, Edward, J.**; Coudert Brothers LLP, 600 Beach Street, 3rd Floor, San Francisco, CA 94109 (US).

(81) Designated States (national): AE, AG, AL, AM, AT, AU, AZ, BA, BB, BG, BR, BY, BZ, CA, CH, CN, CO, CR, CU, CZ, DE, DK, DM, DZ, EC, EE, ES, FI, GB, GD, GE, GH, GM, HR, HU, ID, IL, IN, IS, JP, KE, KG, KP, KR, KZ, LC, LK, LR, LS, LT, LU, LV, MA, MD, MG, MK, MN, MW,

[Continued on next page]

(54) Title: METHOD AND APPARATUS FOR THE DETECTION AND LIGATION OF UTERINE ARTERIES

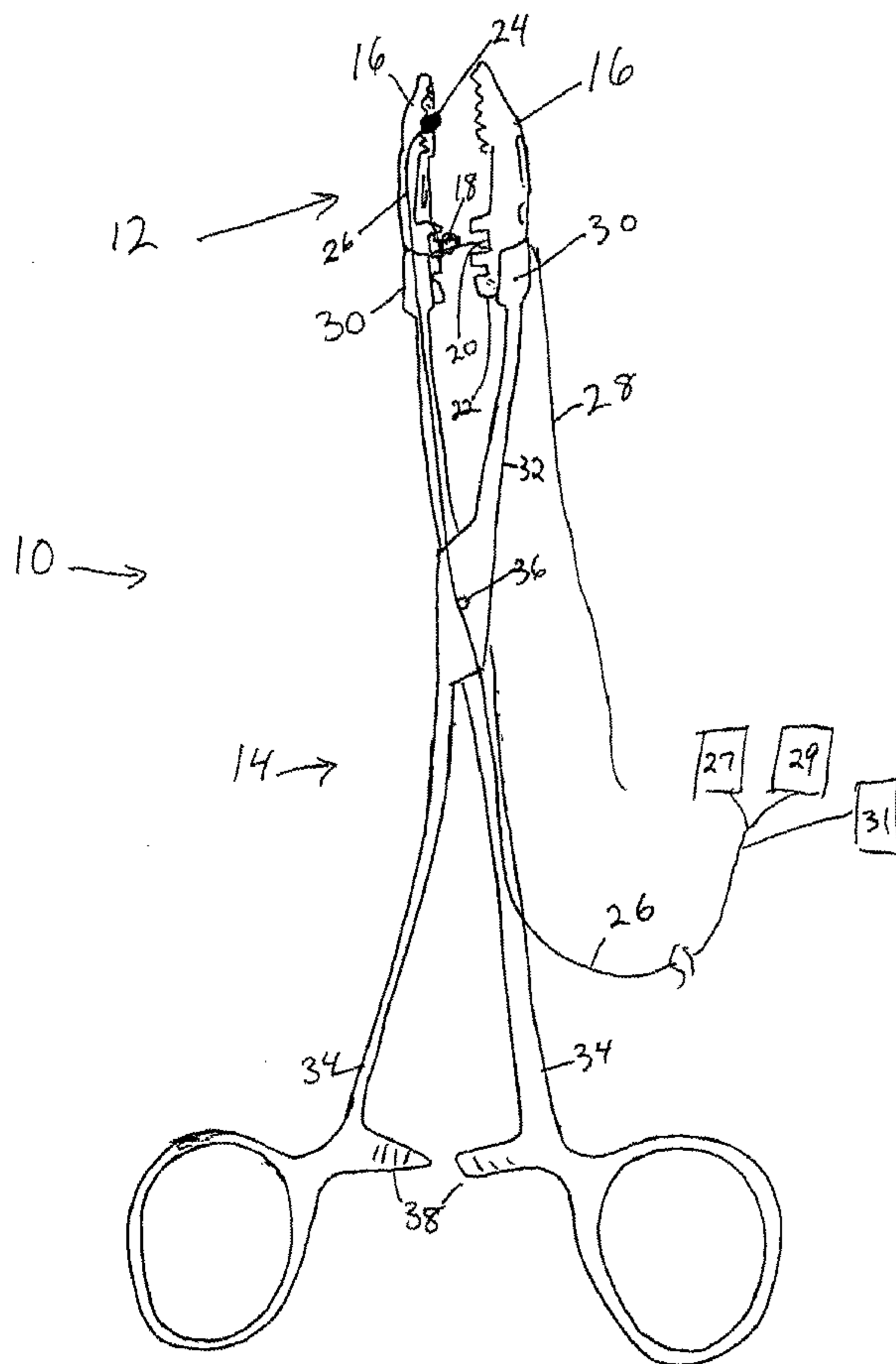
**(57) Abstract:** The invention provides devices, systems and methods for occluding arteries without puncturing skin or vessel walls. The devices, systems and methods for occluding arteries are configured to be applied to arteries externally of the arteries. Occlusion may be temporary or permanent, and may be partial or complete. Clamping a device to tissue near to an artery is effective to compress tissue around the artery and to indirectly compress the artery. The methods, devices and systems of the invention find use in, for example, treatment of uterine disorders and conditions which may be treated by occlusion of the uterine arteries. A uterine artery may be access via a patient's vagina by compressing a portion of the vaginal wall around a portion of a uterine artery to occlude a uterine artery. Clamping of an artery may also be performed by clamping a device directly onto an artery.

WO 02/078549 A3



MX, MZ, NO, NZ, OM, PH, PL, PT, RO, RU, SD, SE, SG,
SI, SK, SL, TJ, TM, TN, TR, TT, TZ, UA, UG, US, UZ,
VN, YU, ZA, ZM, ZW.

Published:

— *with international search report*

(84) Designated States (regional): ARIPO patent (GH, GM, KE, LS, MW, MZ, SD, SL, SZ, TZ, UG, ZM, ZW), Eurasian patent (AM, AZ, BY, KG, KZ, MD, RU, TJ, TM), European patent (AT, BE, CH, CY, DE, DK, ES, FI, FR, GB, GR, IE, IT, LU, MC, NL, PT, SE, TR), OAPI patent (BF, BJ, CF, CG, CI, CM, GA, GN, GQ, GW, ML, MR, NE, SN, TD, TG).

(88) Date of publication of the international search report:

3 January 2003

For two-letter codes and other abbreviations, refer to the "Guidance Notes on Codes and Abbreviations" appearing at the beginning of each regular issue of the PCT Gazette.

METHOD AND APPARATUS FOR THE DETECTION AND LIGATION OF UTERINE ARTERIES

FIELD OF THE INVENTION

[0001] The invention relates generally to the field of treatment of diseases and conditions by regulation of blood flow; in particular, the treatment of a uterus by regulating blood flow thereto.

BACKGROUND OF THE INVENTION

[0002] Hysterectomy (surgical removal of the uterus) is performed on approximately 600,000 women annually in the United States. For approximately 340,000 women, hysterectomy is probably the best current therapeutic choice for the treatment of their diseases (uterine cancer, endometriosis, menorrhagia, and prolapse). For approximately 60,000 women with dysfunctional uterine bleeding (abnormal menstrual bleeding that has no discrete anatomic explanation such as a tumor or growth), newer endometrial ablation techniques may be an alternative to hysterectomy. For approximately 200,000 women with benign but symptomatic (excessive bleeding, pain, and "bulk" sensations) muscular tumors of the uterus, known as leiomyoma or fibroids, newer treatment methods have been developed which may spare these women a hysterectomy, as well.

[0003] Hysterectomy for treating uterine fibroid disorders, though effective, has many undesirable characteristics. Thus, any method which can approximate the therapeutic result of a hysterectomy without removing the uterus (and commonly the ovaries since they are closely adjacent to the uterus) would be a significant improvement in this field.

[0004] The undesirable characteristics of hysterectomy include a known mortality rate of 0.5 deaths per 1000 hysterectomies. Stated another way, the risk

of death within 30 days of hysterectomy is thirty times greater for women who have had a hysterectomy than for women of similar ages and backgrounds who have not had a hysterectomy. Morbidity (medical symptoms and problems short of death) associated with hysterectomy include possible injury to adjacent organs (the bladder, the ureters, and bowel), hospital stay of approximately one week, five to six weeks of slow recovery to normal activity, three weeks of absence from work, direct medical expenses of at least \$10,000, indirect cost of time away from work, a future three-fold increase in the incidence of cardiovascular disease, decreased sexual pleasure in approximately thirty percent of women, and depression and anxiety for many years after the hysterectomy for approximately eight percent of women.

[0005] The endometrium is a glandular mucous membrane of the uterus, the thickness and structure of which varies with the phase of the menstrual lining. It is normal for portions of the lining to slough off and bleed during menstruation, but many women suffer from painful dysfunctional uterine bleeding or endometritis. Thus, endometrial ablation (removal or destruction of the endometrium) may be an alternative to hysterectomy for approximately 60,000 women. A great many new devices have been invented to perform endometrial ablation to treat dysfunctional uterine bleeding. To distinguish the present invention and its applications from endometrial ablation devices, the endometrial ablation devices will be briefly described. Endometrial devices can be categorized into two major groups: devices which require direct visualization of the endometrium to apply an energy source to ablate the endometrium; and those that do not require visualization for their application.

[0006] Direct visualization of the lining of the uterus is accomplished by placing a hysteroscope through the vagina and into the uterus via the cervical os (opening). The hysteroscope image is then displayed as a color image on a TV monitor adjacent to the patient. The gynecologist then manipulates the hysteroscope and endometrial ablation instrument to ablate the lining of the uterus. Endometrial lining ablation instruments directed by hysteroscope include radiofrequency or electrosurgery loops, roller-balls, and lasers. The goal of all of these hysteroscopic endometrial ablation instruments is to transfer heat energy to the endometrium sufficiently to heat and thereby destroy it. An ablated endometrium cannot respond physiologically or pathologically to hormonal stimulation and cannot, therefore, proliferate and bleed.

[0007] To treat all of the endometrium, it must be entirely visible through the hysteroscope. However, visualization of all of the endometrium is difficult. The uterus must be distended like a water balloon to allow adequate visualization. In this distension process, some women become water intoxicated and hyponatremic. Furthermore, the uterine cavity is an awkward shape, somewhat triangular and often angulated. Directly visualizing each and every square millimeter of endometrial surface and ablating each and every square millimeter is seldom achieved. Consequently, portions of the dysfunctional endometrium may persist and dysfunctional bleeding may continue.

[0008] Because of these hysteroscopic visualization and ablation limitations, alternative methods have been invented to destroy the lining of the uterus without the need at all for visualization of the uterine lining. On such method uses a prototypic instrument, the ThermaChoice.TM. balloon, which is produced by GyneCare, a division of Ethicon, Inc. (see U.S. Pat. No. 5,776,129,

incorporated in its entirety herein). This device is inserted through the vagina into the uterus via the cervical os. The balloon is shaped like a triangle to conform to the shape of the uterus. Once in place, hot fluid is added to the balloon to heat and destroy the uterine lining. Treatment only occurs where the balloon is in adequate contact with the uterine lining. As an alternative, hot fluids can be directly introduced into the uterus (e.g., ENABL brand system manufactured by Innerdyne, Inc., and marketed by U.S. Surgical Corporation).

[0009] Endometrial destruction can also be brought about with chemical damage, photochemical injury, or thermal damage (heat or cold). Energy that reaches and destroys the cells of the endometrial lining of the uterus potentially destroys the uterine lining and thereby treats dysfunctional uterine bleeding.

[0010] Surgically removing fibroids or in situ ablation of uterine fibroids is a bit like eradicating ants in the pantry--they are not all seen from one perspective and there may be a lot of them. Commonly, a diagnosis of uterine fibroids involves the presence of multiple fibroids, often averaging ten fibroids or more per afflicted uterus. Consequently, it is difficult to know which fibroid is causing symptoms to the patient (bleeding, pain, and bulk effects on adjacent organs). Furthermore, fibroids occur at different layers in the uterus. Uterine fibroids can occur adjacent to the lining of the uterus (submucosal fibroid), in the myometrium (intramural fibroid), or adjacent to the outer layer of the uterus (subserosal fibroid). Consequently, if one is directly observing the uterus from the peritoneal cavity, only subserosal fibroids would be seen. If one is directly observing the uterus from the endometrial surface of the uterus, only the submucosal would be seen. Fibroids deep within the wall of the uterus are poorly visualized from either

WO 02/078549

PCT/US02/09775

surface. Finally, since fibroids come in all sizes, only the larger fibroids will be seen in any case.

[0011] Clearly, the strategy of identifying which individual fibroid is causing symptoms (when there are often many), finding that fibroid, and then either removing or destroying that individual fibroid is a rather complex strategy. It is therefore easy to understand why the hysterectomy is such a common surgical choice. With hysterectomy, all uterine fibroids are removed in one stroke.

[0012] In 1995, it was demonstrated that fibroids, in a uterus that contained one or multiple fibroids, could be treated without hysterectomy using a non-surgical therapy, specifically comprising bilateral intraluminal occlusion of the uterine arteries (Ravina et al., "Arterial Embolization to Treat Uterine Myomata", Lancet Sept. 9, 1995; Vol. 346; pp. 671-672, incorporated in its entirety herein). This technique is known as "uterine artery embolization". The technique uses standard interventional radiology angiographic techniques and equipment, whereby the uterine arteries are accessed via a transvascular route from a common femoral artery into the left and right uterine arteries.

[0013] Three facts explain the success of uterine artery embolization. First, it has been established that pelvic bleeding from a wide variety of sources (e.g., auto accidents, surgical errors, and post partum hemorrhage) can be effectively controlled with embolization techniques using coils placed in arterial and venous lumens (U.S. Pat. No. 4,994,069, 5,226,911, and 5,549,824, all of which are incorporated in their entireties herein) (available from Target Therapeutics), or particles (GELFOAM^{*} pledgets, available from Upjohn, Kalamazoo, Mich., or IVALON particles, available from Boston Scientific).

*-trademark

WO 02/078549

PCT/US02/09775

[0014] Second, fibroids live a tenuous vascular life with very little ability to recruit a new blood supply from the host when the primary blood supply is compromised. Third, the uterus has a dual (or redundant) blood supply, the primary blood supply being from the bilateral uterine arteries, and the secondary blood supply from the bilateral ovarian arteries.

[0015] Consequently, when both uterine arteries are occluded, i.e. bilateral vessel occlusion, the uterus and the fibroids contained within the uterus are both deprived of their blood supply. However, as demonstrated by Ravina et al., the effect on the fibroid is greater than the effect on the uterus. In most instances, the fibroid withers and ceases to cause clinical symptoms.

[0016] The uterine artery embolization technique utilized by Ravina et al. uses standard transvascular equipment, available in typical interventional radiology angiography suite. This equipment includes guide catheters to selectively enter the tortuous right and left uterine arteries, Ivalon or Gelfoam^{*} particles, and intravascular coils. With skill and these standard angiographic tools, the uterine arteries can be occluded bilaterally and fibroid disease treated through a 2 mm hole in the right groin and through the right common femoral artery. Following the procedure, the arterial puncture site is held with manual pressure for fifteen minutes. While post-procedural pain is often significant, and requires intravenously delivered pain medication, the patient is typically fully recovered in a few days.

[0017] One problem with present methods of uterine artery embolization is that many physicians do not possess the skill or equipment necessary to perform catheter-based uterine artery embolization under radiologic direction.

Accordingly, only hundreds of uterine artery embolizations have been performed,

*-trademark

worldwide, over the past three years, whereas hundreds of thousands of hysterectomies have been performed each year for uterine fibroids which are symptomatic.

[0018] What is needed, therefore, are devices and methods to occlude arteries such as the uterine arteries.

SUMMARY OF THE INVENTION

[0019] The invention is directed to devices, systems and methods for occluding arteries such as the uterine arteries. In particular, the invention is directed to devices, systems and methods for occluding arteries from outside the arteries; that is, to devices, systems and methods configured to be applied to arteries externally of the arteries. Occlusion may be temporary or permanent, and may be partial or complete. One method of occluding an artery comprises clamping the artery so that blood flow through the artery is reduced, or is completely stopped. Such clamping of an artery may be direct or may be indirect. Thus, clamping of an artery may be accomplished by applying a clamping device directly onto an artery effective to compress the artery, or may be accomplished by applying a clamping device to tissue near to an artery effective to compress the artery.

[0020] Clamping devices embodying features of the invention include clamping devices having a clamping member configured to apply pressure to a blood vessel and a blood flow sensor. A clamping member may have a distal portion configured to engage tissue. Clamping devices embodying features of the invention may have two, or more, clamping members. Two clamping members may be disposed opposite each other and configured to move or apply pressure

towards each other, such as to close together, effective to engage tissue and to clamp a blood vessel between them.

[0021] A blood flow sensor preferably includes doppler ultrasound sensor. A blood flow sensor may be disposed on a clamping member, preferably on a distal portion configured to engage tissue, more preferably near the middle of the distal portion. A blood flow sensor disposed on a clamping member may be configured to detect blood flow in a blood vessel near said clamping member, and may be configured to detect blood flow in a blood vessel clamped by a clamping member. Clamping devices embodying features of the invention may include more than one blood flow sensor.

[0022] Clamping devices may be configured to be held by a clamping device applicator. A clamping device applicator embodying features of the invention may be used to deliver a clamping device to a desired location. A clamping device applicator includes an engagement member configured to hold and to release a clamping device, and a delivery member configured to deliver a clamping device to a desired location. A clamping device applicator may be used to close together clamping members of a clamping device, to apply pressure to clamping members, and to apply pressure to tissue disposed between clamping members of a clamping device. A clamping device applicator may include an elongated arm or arms effective to place a clamping device at a desired location within a patient's body, such as adjacent a vaginal wall within a vagina near to a uterine artery.

[0023] Clamping device embodying features of the invention may be configured to lock into a clamping position. Such a locked configuration may be temporary and releasable, or may be permanent. Clamping devices embodying

features of the invention may have a ratchet mechanism configured to hold at least one clamping member in a clamping position; such ratchet mechanisms may be releasable ratchet mechanisms.

[0024] Clamping devices embodying features of the invention may include a release mechanism configured to release a locking mechanism such as a ratchet effective to release the clamping of a blood vessel. Clamping devices embodying features of the invention may include a recovery member configured to aid the removal of the clamping device from a patient and the recovery of the device after release of the clamping of a blood vessel. For example, a recovery member may include a lanyard or other cord or cable device.

[0025] The invention further provides systems for occluding a blood vessel, including a clamping device having a clamping member configured to apply pressure to a blood vessel, and a blood flow sensor, and a clamping device applicator configured to engage a clamping device. The blood flow sensor in such systems is preferably a doppler ultrasound sensor.

[0026] Methods and devices embodying features of the invention may be used to occlude any artery; in the following discussion, the uterine artery is used as an example. It will be understood that the methods and devices discussed in regard to this example may also be applied to any other artery.

[0027] One method of occluding a uterine artery includes applying a clamping device to the artery so that blood flow through the artery is reduced, or is completely stopped. Such clamping of a uterine artery may be direct or may be indirect. Clamping of the artery may be accomplished by applying a clamping device directly onto a uterine artery effective to compress the uterine artery, or

may be accomplished by applying a clamping device to tissue near to a uterine artery effective to compress the uterine artery.

[0028] A method of occluding an artery includes sensing an artery, and compressing an artery with a clamping device having a blood flow sensor. Sensing an artery may include sensing blood flow, such as blood flow in an artery. Compressing an artery may include grasping tissue near to an artery, and may include compressing tissue surrounding an artery effective to compress the artery.

[0029] Thus, a method of occluding a uterine artery includes sensing a uterine artery, and compressing a uterine artery with a clamping device having a blood flow sensor. Accessing a uterine artery may include accessing a uterine artery via the vagina of a patient with a uterine artery. Compressing a uterine artery may include grasping tissue near to a uterine artery, and may include compressing tissue surrounding a uterine artery effective to compress the uterine artery. A method of occluding a uterine artery includes accessing a uterine artery via a vagina, and compressing a portion of a vagina wall with a clamping device having a blood flow sensor. A method of occluding uterine artery may also include sensing blood flow in a uterine artery. Sensing blood flow in a uterine artery may include sensing blood flow in a uterine artery through a wall of a vagina. A method of occluding blood flow in a uterine artery may include sensing a reduction or cessation of blood flow following application of a clamp.

[0030] A method of occluding a uterine artery includes applying a clamping device having a blood flow sensor to the artery so that blood flow through the artery is reduced, or is completely stopped, and the reduction or cessation of blood flow is sensed by the blood flow sensor. A blood flow sensor is also effective to locate the artery by sensing blood flow before application of the

clamping device. A particularly suitable blood flow sensor is a doppler ultrasound sensor. A uterine artery may be clamped effective to compress the uterine artery by applying a clamping device directly onto a uterine artery, or by applying a clamping device to tissue near to a uterine artery.

[0031] A method of occluding a uterine artery of a patient includes compressing a portion of a uterine artery with a clamping device comprising a blood flow sensor, and sensing a level of blood flow in the artery with said blood flow sensor. For example, the method may include sensing blood flow in a uterine artery effective to locate a uterine artery. A uterine artery may be accessed via the vagina of a patient, and compressing a uterine artery may be accomplished by compressing a portion of the vaginal wall around a portion of a uterine artery. A clamping device suitable for use in a method embodying features of the invention may be a releasable clamping device, so that a uterine artery may remain occluded for only a limited time. A suitable limited time may be between about 0.2 hours and about 12 hours, or preferably between about 0.5 hours and about 4 hours.

[0032] The devices, systems and methods of the present invention may be used to occlude blood flow in arteries without need for invasive procedures such as puncturing skin or vessel walls. For example, clamping a vaginal wall around a uterine artery is effective to occlude blood flow in that uterine artery without puncturing the skin or a blood vessel of the patient. Such occlusion may be used to treat uterine disorders such as, for example, uterine fibroids, dysfunctional uterine bleeding, and other uterine disorders.

[0033] The devices, systems and methods of the present invention provide the advantages of allowing for the occlusion of an artery without puncture of bodily

tissue, and allowing for arterial occlusion without need for radiographic equipment or skill in the use of radiographic techniques. The devices and methods are simpler and more readily used and removed than other methods and devices, and provide improved treatments for serious conditions and diseases.

BRIEF DESCRIPTION OF THE DRAWINGS

[0034] Figure 1 is a perspective view of a system embodying features of the invention including a clamping device and a clamping device applicator embodying features of the invention.

[0035] Figure 2 is a perspective view of a two portions of a clamping device embodying features of the invention.

[0036] Figure 3 is an elevational view of a clamping device embodying features of the invention.

[0037] Figure 4A is a plan view of a portion of a clamping member of the clamping device of Figure 3 embodying features of the invention.

[0038] Figure 4B is a transverse cross-sectional view of the clamping device of Figure 3 taken at line 4B-4B.

DETAILED DESCRIPTION OF THE PREFERRED EMBODIMENTS

[0039] Figure 1 shows a system 10 embodying features of the invention including a clamping device 12 and a clamping device applicator 14 embodying features of the invention. The clamping device shown in Fig. 1 is a clamp 12 having clamp jaws 16 which act as clamping members. The clamp jaws 16 are shown separated, but may be locked together by action of the clamp device applicator 14 bringing together locking mechanism components detent 18 and catch 20 effective to lock jaws 16 together. Placement of jaws 16 against tissue, such as vaginal wall tissue, surrounding an artery, such as a uterine artery, is

effective to compress an artery between jaws 16 and to clamp and lock together jaws 16 to maintain such compression for a desired length of time. Clamp 12 also has a mounting portion 22 configured to engage a clamp device applicator.

[0040] Fig. 1 further illustrates blood flow sensor 24 located on a jaw 16 where it may sense blood flow in an artery within tissue near a clamp 12. Blood flow sensor cable 26 is effective to carry electrical power and electrical signals to and from power apparatus 27, sensing apparatus 29 and control apparatus 31 all of which are operably connected to the blood flow sensor 24 via a cable 26. As is known in the art, such power, sensing and control apparatus are effective to operate a blood flow sensor 24 and to provide an operator with blood flow information sensed by a blood flow sensor 24. Release and recovery of the clamp 12 may be effected by a lanyard 28, as illustrated in Fig. 1, or by other suitable means.

[0041] A clamp device applicator 14 is configured to hold a clamp 12 and to deliver it to a desired location, and optionally to apply force effective to compress tissue and optionally to lock a clamp 12 into a desired configuration. The clamp applicator 14 shown in Fig. 1 has clamp holders 30 configured to engage a clamp 12, mounted on arms 32 which are operably connected to handles 34, as by applicator pivot 36 shown in Fig. 1, to provide mechanical support for and to allow the application of force to a clamp 12. A clamp device applicator may be locked into a desired configuration with an applicator lock, such as the applicator lock 38 illustrated in Fig. 1.

[0042] Figure 2 is a perspective view of a two portions of a clamping device 12 embodying features of the invention, shown free of a clamp applicator 14.

Jaws 16 are configured to engage and hold tissue, and may be locked together by

a locking mechanism shown here comprising detent 18 and catch 20. Also shown are guide members 40 and 42 configured to guide the engagement of jaws 16 together. Extending guide member 40 is configured to fit within enclosing guide member 42 and to aid in the proper location and fitting of jaws 16 when jaws 16 approach one another in a compressing engagement effective to compress tissue, including vascular tissue, between jaws 16.

[0043] Figure 3 illustrates an alternative embodiment of a clamp 12 embodying features of the invention. This clamp 12 comprises a single clamp 12 with two jaws 16 connected by clamp pivot 48. A locking mechanism including a pawl 44 and a ratchet 46 are configured to engage with each other to lock jaws 16 in a desired configuration. Also shown are a blood flow sensor 24 with cable 26, and a lanyard 28.

[0044] Figure 4A is a plan view of a portion of a portion of a jaw 16 of the clamping device 12 illustrated in Figure 3 embodying features of the invention. A clamping surface 50 is shown, with a blood flow sensor 24 disposed on the clamping surface 50.

[0045] Figure 4B is a transverse cross-sectional view of the clamping device 12 of Figure 3 taken at line 4B-4B showing portions of the jaws 16, clamping surface 50 and blood flow sensor 24.

[0046] Clamping devices embodying features of the invention include clamps, ratchets, jaws, clips, wires, sutures, coils, or other structures or devices. Clamping devices preferably include at least one clamping member configured to directly or indirectly apply pressure to a blood vessel or to urge movement of a blood vessel. Clamping devices may also include a clamping surface, such as an anvil, against which a blood vessel may be directly or indirectly urged. A clamping

member may serve as a clamping surface for another clamping member. A clamping member may be configured to urge a blood vessel towards a clamping surface or towards another clamping member. Methods for applying clamping devices include grasping, probing, penetrating, deflecting, invaginating, and dilating tissue or vessels.

[0047] Clamping devices embodying features of the invention may also include at least one blood flow sensor configured to sense blood flow in vessels. A blood flow sensor is preferably disposed on a clamping member, such as a jaw of a clamp, in a position to sense blood flow near a clamping member when the clamping device is near to a blood vessel, and in a position to contact a blood vessel when the clamping device is applied directly to a blood vessel. Alternatively, a blood flow sensor may be disposed on a clamping surface, or other location on a clamping device effective to sense blood flow in vessels near the clamping device and to aid in guiding the clamping device to a desired location near a blood vessel. A particularly suitable blood flow sensor is a doppler ultrasound sensor.

[0048] A clamping device may be applied alone, or may be applied with a clamping device applicator. A clamping device that is applied to a blood vessel using a clamping device applicator may be configured to be received by the applicator, and to be applied by it. A clamping device applied by an applicator may have a clamping member configured to move under the influence of a clamping device applicator. Where a clamping device has a plurality of clamping members, some clamping members may be configured to close or to close together under the influence of a clamping device applicator.

[0049] Clamping devices embodying features of the invention may be made from any suitable material or combination of materials, including metals such as stainless steel and shape memory alloys such as nickel titanium alloys, plastics, ceramics, and other biocompatible materials known in the art. Biocompatible polymers, such as for example, polycarbonate, polysulfone, polyester, polyacetal, and other polymers may be particularly suitable for embodiments of the invention.

[0050] Blood flow sensors may be any blood flow sensor. Preferred blood flow sensors include doppler or near infra-red blood flow sensors. A sensing box may be included to receive and process data in the analysis of blood flow. A clamping system may be configured to provide Doppler, near infra-red spectrometric imaging of arteries to non-destructively locate and ligate or occlude identified arteries. The device or system may be designed for single use (disposable) or may be sterilizable and capable of multiple use.

CLAIMS

We Claim:

1. An intravaginal clamping device for occluding a female patient's uterine artery, comprising: a) a pair of releasable clamping members which are configured to press against the patient's vaginal tissue, which have opposed clamping surfaces and which are releasably lockable in a clamped configuration to apply pressure to the patient's vaginal tissue to occlude an underlying uterine artery, b) an ultrasonic blood flow sensor on at least one of the clamping surfaces for locating the patient's uterine artery or for detecting blood flow therethrough, and c) a delivery mechanism comprising connected handles, wherein each of the clamping members is releasably secured to clamp applicators on distal portions of said handles.
2. The clamping device of claim 1, wherein said blood flow sensor comprises a doppler ultrasound sensor.
3. The clamping device of claim 1 wherein the pair of clamping members are disposed with clamping surfaces thereof in an opposing relationship with respect to each other.
4. The clamping device of claim 3, wherein the clamping members are configured to be closed together so that at least one clamping surface thereof applies sufficient pressure to the patients uterine artery to at least partially occlude the artery.
5. The clamping device of claim 3, wherein the two clamping members are configured to be closed together by said clamp applicators.
6. The clamping device of claim 1, wherein the clamping members are lockable by a ratchet mechanism configured to hold the clamping members in a clamping position.
7. The clamping device of claim 6, wherein said ratchet mechanism has an unlocking mechanism.
8. The device of claim 7 wherein the unlocking mechanism is a cord.
9. The device of claim 8 wherein the cord is a lanyard.

10. The clamping device of claim 1, wherein the clamping surfaces of the clamping members are on distal portions of the clamping members.
11. The clamping device of claim 10, wherein the blood flow sensor is disposed on a clamping surface of at least one of the clamping members.
12. The device of claim 1 wherein the pair of releasable clamping members has an extending guide member configured to fit within an enclosing guide member.
13. The clamping device of claim 1 including a clamping device applicator configured for intravaginal delivery and having one elongated member configured to releasably engage one clamping member and one elongated member configured to releasably engage the other clamping member.
14. The device of claim 13, wherein said blood flow sensor comprises a doppler ultrasound sensor.
15. The device of claim 13, comprising a plurality of blood flow sensors.
16. The device of claim 13 wherein at least one of the clamping members has a recovery member.
17. The device of claim 16, wherein said recovery member comprises a lanyard.
18. The system of claim 13 wherein the releasable clamping assembly has an extending guide member configured to fit within an enclosing guide member.
19. The uterine artery occluding device of claim 18 wherein the blood flow sensor on the pressure applying surface of one of the releasable clamping elements has a sensing direction toward the pressure applying surface of the other releasable clamping element.
20. A uterine artery occluding device, comprising: a. a first elongated pressure applying member which has a proximal handle portion, a distal handle portion and a first clamping element which is releasably disposed on the distal handle portion and which has a pressure applying surface; b. a second elongated pressure applying member which has a proximal handle portion, a distal handle portion and a second clamping element which is releasably disposed on the distal handle portion and

which has a pressure applying surface; c. a pivotal connection between the first and second pressure applying members at a location proximal to the releasable clamping element and distal to the proximal handle portions thereof; and d. an ultrasonic blood flow sensor disposed on the pressure applying surface of at least one of the releasable clamping elements.

21. The uterine artery occluding device of claim 20 wherein the releasable clamping elements are configured to engage the patient's vaginal fornix and clamp against the tissue thereof to occlude an underlying uterine artery.

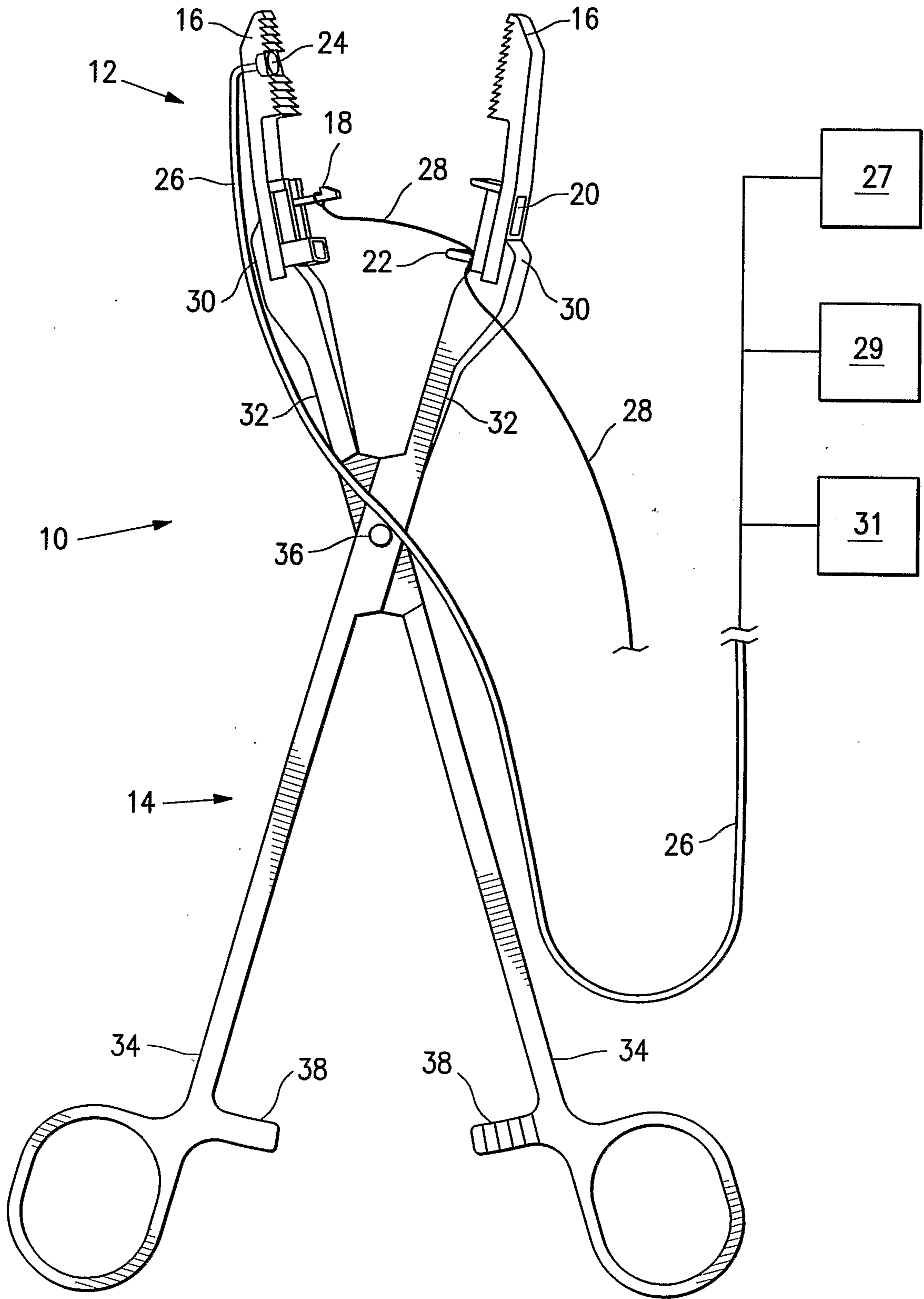

FIG. 1

AMENDED SHEET

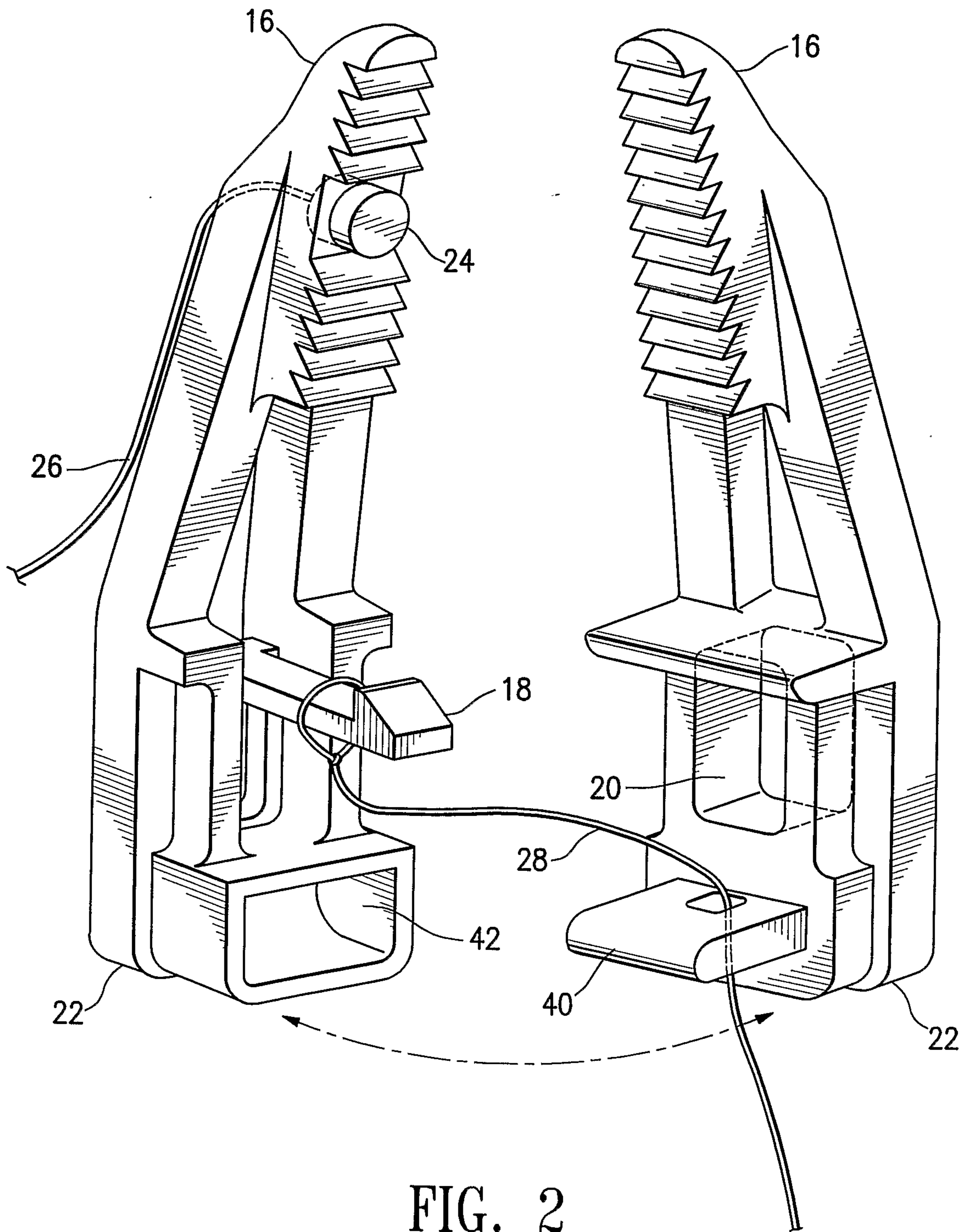

FIG. 2

3/3

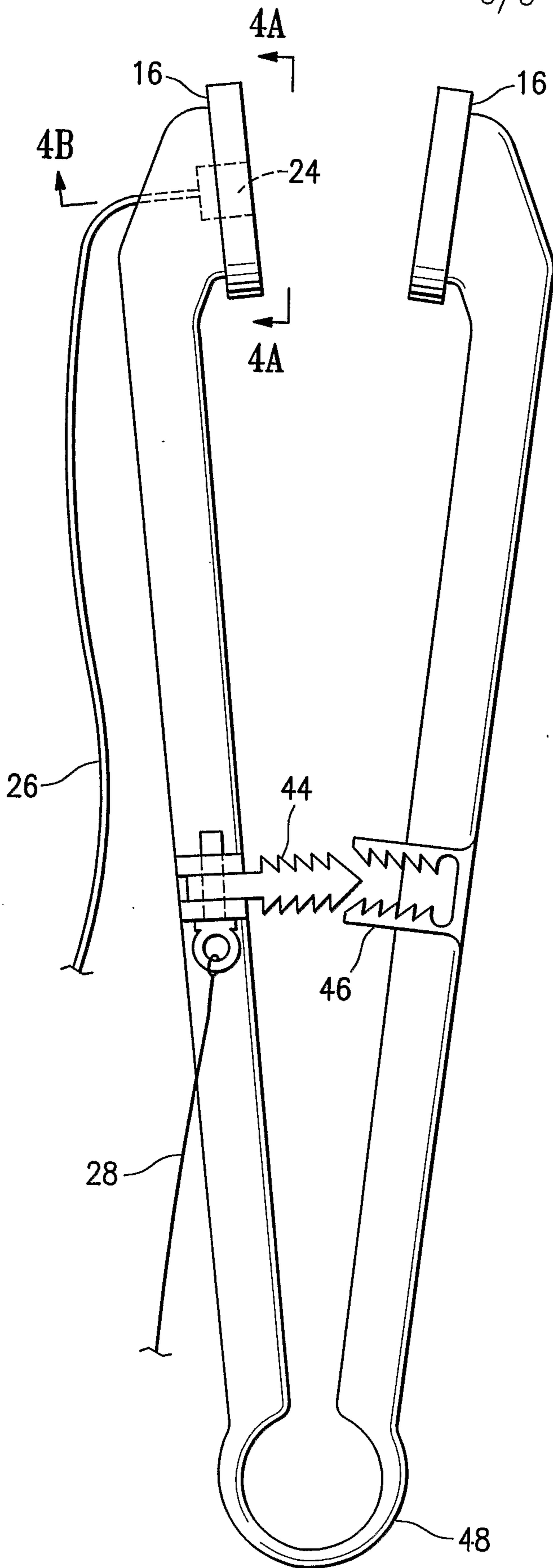

FIG. 3

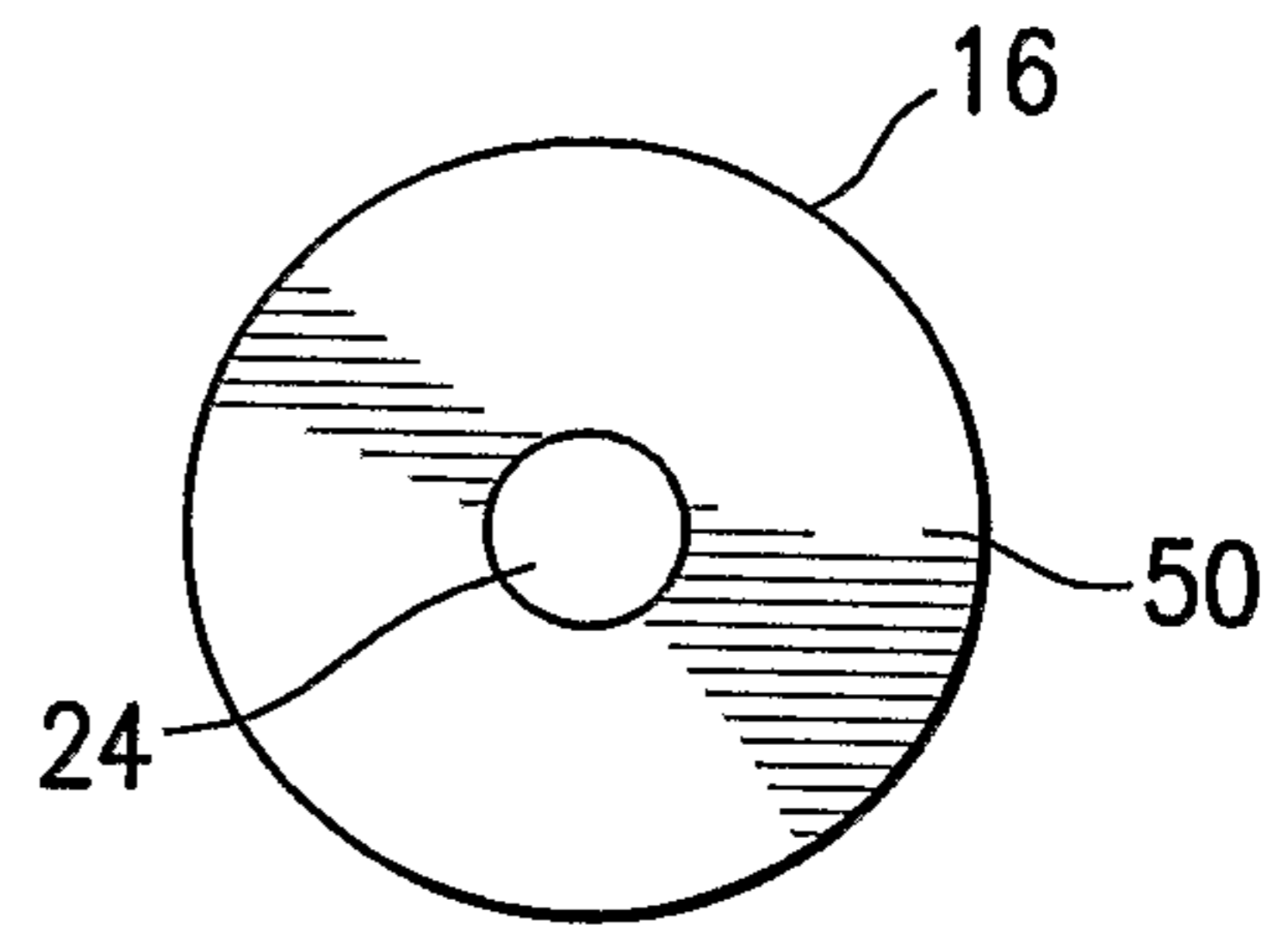

FIG. 4A

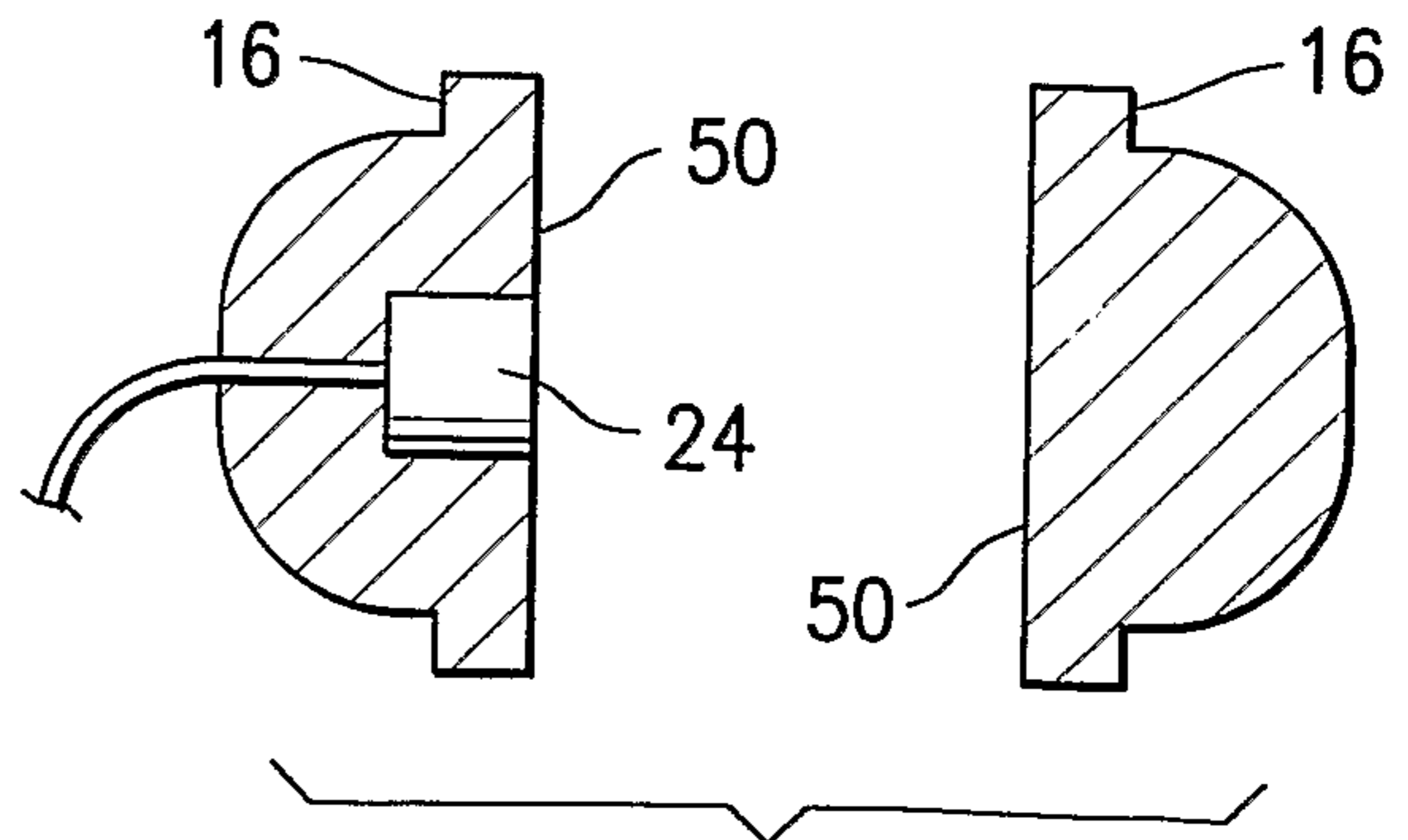

FIG. 4B

