

81890/87  
601242 Form 9

APPLICATION FOR A STANDARD PATENT

I/We HOUSE FOOD INDUSTRIAL COMPANY LIMITED,  
a corporation incorporated under the laws of Japan,  
and whose registered office is situate at 5-7, Sakae-machi  
1-chome, Mikuriya, Higashiosaka-shi, Osaka-fu, JAPAN

hereby apply for the grant of a ~~Patent of Addition~~ Standard Patent for an invention entitled

"METHOD AND APPARATUS FOR FEEDING SOLID-LIQUID MIXTURE"

which is described in the accompanying ~~provisional~~ complete specification.

For a Convention application — details of basic application(s) —

LODGED AT SUB-OFFICE

27 NOV 1987

Adelaide

NUMBER	COUNTRY	DATE OF APPLICATION
283925/1986	JAPAN	28th November, 1986
153134/1987	JAPAN	19th June, 1987

— For an application made by virtue of section 51 —

Original Application No. —

by

~~I request that the Patent may be granted as a Patent of Addition~~

~~the Patent applied for on Application No.~~ APPLICATION ACCEPTED AND AMENDMENTS

to

Patent No. —

in the name of

ALLOWED

28-6-90

~~I request that the term of the Patent of Addition be the same as that for the main invention or so much of the term of the patent for the main invention as is unexpired.~~

Our My address for service is COLLISON & CO., Patent Attorneys, ~~Savings Bank Building, 97 King William Street, Adelaide, South Australia, 5000.~~ 117

Dated this 19th day of November, 19 87  
HOUSE FOOD INDUSTRIAL COMPANY LIMITED

*Ko Sugisawa*

Ko SUGISAWA, Managing Director  
(Signature)

~~(To be completed where application is made by a person other than the applicant for, or the patentee under, the patent for the main invention.)~~

~~applicant for Application No. —~~

~~the~~

~~patentee of Patent No. —~~

~~— hereby consent to this application.~~

Dated this

FEE STAMP TO VALUE OF  
\$ 270 ATTACHED  
MAIL OFFICER.....

day of

19

To:

(Signature)

THE COMMISSIONER OF PATENTS

#o/4374



Patents Act 1952

**DECLARATION IN SUPPORT OF A CONVENTION  
APPLICATION FOR A PATENT**

In support of the Convention application made for a patent for an invention entitled:

"METHOD AND APPARATUS FOR FEEDING SOLID-LIQUID MIXTURE"

1. Ko SUGISAWA, Managing Director of HOUSE FOOD INDUSTRIAL COMPANY LIMITED, a corporation incorporated under the laws of Japan and whose registered office is situate at 5-7, Sakae-machi 1-chome, Mikuriya, Higashiosaka-shi, Osaka-fu, JAPAN  
do solemnly and sincerely declare as follows:

~~1. I am the applicant for the patent.~~

*(or, in the case of an application by a body corporate)*

1. I am authorized by HOUSE FOOD INDUSTRIAL COMPANY LIMITED, the applicant for the patent to make this declaration on its behalf.

2. The basic application as defined by section 141 of the Act was made in JAPAN on the 28th day of November, 1986, by HOUSE FOOD INDUSTRIAL COMPANY LIMITED  
19th day of June, 1987, by HOUSE FOOD INDUSTRIAL COMPANY LIMITED

~~3. I am the actual inventor of the invention referred to in the basic application.~~

*(or, where a person other than the inventor is the applicant)*

3. Hiroshi SAWADA, Masayuki NAKATANI, Hitoshi IWATA and Katsuaki NAMBA, respectively of : 243-21, Oaza-Uchiage, Neyagawa-shi, Osaka-fu, JAPAN; 57-204, Heijou-2nd-Danchi, 2, Ukyo 2-chome, Nara-shi, Nara-ken, JAPAN; 2-32, Koaza-Kuwanoki, Oaza-Takigi, Tanabe-cho, Tsuzuki-gun, Kyoto-fu, JAPAN; and 201, Nakai-Haitsu, 1173-1, Ichibu-cho, Ikoma-shi, Nara-ken, JAPAN  
are ~~is~~ the actual inventor of the invention and the facts upon which ~~I am entitled~~ the applicant company is entitled to make the application are as follows:

The applicant company is the assignee of the actual inventors Hiroshi SAWADA, Masayuki NAKATANI, Hitoshi IWATA and Katsuaki NAMBA.

4. The basic application referred to in paragraph 2 of this Declaration was the first application made in a Convention country in respect of the invention the subject of the application.

~~(or where a request is made under section 142AA of the Patents Act 1952, for an earlier application made in a Convention country to be disregarded)~~

~~4. (1.) The basic application referred to in paragraph 2 of this Declaration was not the first application made in a Convention country in respect of the invention the subject of the application.~~

~~(2.) An earlier application in respect of the invention the subject of the application was made in~~

~~or~~

~~(3.) A request has been made to you under section 142AA of the Patents Act 1952 to disregard that earlier application.~~

~~(Here set out in succeeding sub-paragraphs the facts that show that section 142AA is applicable)~~

Except as stated in this paragraph, the basic application referred to in paragraph 2 of this Declaration was the first application made in a Convention country in respect of the invention the subject of the application.

Declared at Osaka-fu, Japan, this 19th day of November, 1987

HOUSE FOOD INDUSTRIAL COMPANY LIMITED

*Ko Sugisawa*

*(Signature of Declarant)*

Ko SUGISAWA, Managing Director

THE COMMISSIONER OF PATENTS.

(IMPORTANT - Cross out inapplicable words in above Form.)

**(12) PATENT ABRIDGMENT (11) Document No. AU-B-81890/87**  
**(19) AUSTRALIAN PATENT OFFICE (10) Acceptance No. 601242**

(54) Title  
**METHOD AND APPARATUS FOR FEEDING SOLID-LIQUID MIXTURE**

International Patent Classification(s)  
(51)<sup>4</sup> **B65B 003/06**

(21) Application No. : **81890/87** (22) Application Date : **27.11.87**

(30) Priority Data

(31) Number	(32) Date	(33) Country
<b>61-283925</b>	<b>28.11.86</b>	<b>JP JAPAN</b>
<b>62-153134</b>	<b>19.06.87</b>	<b>JP JAPAN</b>

(43) Publication Date : **02.06.88**

(44) Publication Date of Accepted Application : **06.09.90**

(71) Applicant(s)  
**HOUSE FOOD INDUSTRIAL COMPANY LIMITED**

(72) Inventor(s)  
**HIROSHI SAWADA; MASAYUKI NAKATANI; HITOSHI IWATA; KATSUAKI NAMBA**

(74) Attorney or Agent  
**COLLISON & CO.**

(56) Prior Art Documents  
**US 3029069**  
**GB 2146617**

(57) Claim

1. A method for feeding a solid-liquid mixture comprising at least one liquid component and at least one solid component having a specific gravity greater than that of the liquid component into a receiving container, comprising the steps of:

(a) providing a mixing container having a feed opening at the bottom thereof;

(b) providing a receiving container in fluid communication with the feed opening the mixing container;

(c) introducing the solid-liquid mixture into the mixing container;

(d) allowing the solid component of the solid-liquid mixture to separate from the liquid component;

(e) depositing the separated solid component around the feed opening in the mixing container; and

(f) feeding the solid-liquid mixture through the feed opening into the receiving container.

4. An apparatus for feeding a solid-liquid mixture comprising at least one liquid component and at least one solid component having a

(11) AU-B-81890/87  
(10) 601242

-2-

specific gravity greater than that of the liquid component in a desired and constant mixing ratio, comprising:

a mixing container having a bottom and a feed opening disposed at said bottom thereof;

a feed-controlling device disposed in the vicinity of said feed opening;

rotatable collecting means disposed in said mixing container for collecting the solid component of the mixture around said feed opening; and

drive means for rotating said collecting means at a speed of sufficient slowness that the solid component of the mixture is not propelled up from said bottom of said mixing container by the rotation of said collecting means, wherein the solid component is allowed to separate from the liquid component and is deposited at said bottom of said container.

COMMONWEALTH OF AUSTRALIA

Patents Act 1952-1969

601242<sup>10</sup>

# COMPLETE SPECIFICATION

(ORIGINAL)

FOR OFFICE USE:

Class

Int. Class

Application Number :  
Lodged :

Complete Application No. ;  
Specification Lodged ;  
Published :

Priority:

Related art:

This document contains the amendments made under Section 49 and is correct for printing.

---

TO BE COMPLETED BY APPLICANT

Name of Applicant:

HOUSE FOOD INDUSTRIAL COMPANY LIMITED

Address of Applicant:

5-7, Sakae-machi 1-chome, Mikuriya,  
Higashiosaka-shi, Osaka-fu, JAPAN

Actual Inventor:

Hiroshi SAWADA  
Masayuki NAKATANI

Hitoshi IWATA  
Katsuaki NAMBA

Address for Service: COLLISON & CO., Patent Attorneys, 117 King William Street, Adelaide, South Australia, 5000.

Complete Specification for the invention entitled: "METHOD AND APPARATUS FOR FEEDING SOLID-LIQUID MIXTURE"

The following statement is a full description of this invention, including the best method of performing it known to ~~me~~ us:

---

## SPECIFICATION

### TITLE OF THE INVENTION

Method and Apparatus for Feeding Solid-Liquid Mixture

### BACKGROUND OF THE INVENTION

5

#### Field of the Invention

The present invention relates to a method for feeding a solid-liquid mixture and an apparatus therefor and more particular to a method adapted for feeding or dispensing a solid-liquid mixture such as stew, soup, curry and sauce into a container such as packing bags as well as an apparatus therefor.

#### Description of the Prior Art

Heretofore, apparatuses for feeding a solid-liquid mixture such as those listed above to a container in a desired mixing ratio and a constant amount have been known. For instance, there is known an apparatus in which a solid-liquid mixture is fed to a container while agitating the mixture with blades for agitation. However, in such an apparatus, particles of the solid component present in the mixture collide with each other due to the agitation as well as the blades collide with the solid particles. As a result, the solid particles suffer from damages and are destroyed and moreover, bubbles are formed in the solid-liquid mixture depending on the rotational speed of the blades, which leads to lowering of the commercial value of the resultant goods and the reduction of the precision in the metring of the mixture during filling.

In addition, there is known another apparatus for feeding or dispensing a solid-liquid mixture into a container in a desired mixing ratio, in which the solid-liquid mixture is agitated by blowing air into the solid-liquid mixture. However, in this apparatus, it is difficult to avoid the solid component from causing collisions with each other, which leads to the destruction of the solid component and the formation of bubbles in the mixture becomes more severe problem as compared with the aforementioned apparatus provided with blades for agitation.

#### SUMMARY OF THE INVENTION

Under such circumstances, it has been expected to develop a method and an apparatus for feeding a solid-liquid mixture into a proper container in a desired amount and a constant mixing ratio, which do not suffer from the foregoing drawbacks associated with the conventional methods and apparatuses.

Accordingly, it is a primary object of the present invention to provide a simple method for feeding a solid-liquid mixture to a container, which surely avoids the solid component from being damaged and destroyed and which makes it possible to certainly control and maintain a desired mixing ratio between the solid and liquid components throughout the dispensing operations.

It is another object of the present invention to provide an apparatus for feeding a solid-liquid mixture into a proper container, which does not cause damages and

destruction of the solid component and which permits the easy control and maintenance of the mixing ratio of the mixture.

5 It is still another objection of the present invention to provide an apparatus for feeding a solid-liquid mixture to an apparatus for filling or dispensing the mixture into a proper container without causing the formation of bubbles in the mixture.

10 The aforementioned and other objects of the present invention can certainly be accomplished, on the one hand, by providing an apparatus for feeding a solid-liquid mixture comprising at least one liquid component and at least one solid component having a specific gravity greater than that of the liquid component in a desired and  
15 constant mixing ratio, comprising:

a mixing container having a bottom and a feed opening disposed at said bottom thereof;

a feed-controlling device disposed in the vicinity of said feed opening;

20 rotatable collecting means disposed in said mixing container for collecting the solid component of the mixture around said feed opening; and

drive means for rotating said collecting means at a speed of sufficient slowness that the solid component of the mixture is not  
25 propelled up from said bottom of said mixing container by the rotation of said collecting means, wherein the solid component is allowed to separate from the liquid component and is deposited at said bottom of said container.

30 According to another aspect of the present invention, there is provided a method for feeding a solid-liquid mixture comprising at least one liquid component and at least one solid component having a specific gravity greater than that of the liquid component into a receiving container, comprising the steps of:

35 (a) providing a mixing container having a feed opening at the bottom thereof;



(b) providing a receiving container in fluid communication with the feed opening the mixing container;

5 (c) introducing the solid-liquid mixture into the mixing container;

(d) allowing the solid component of the solid-liquid mixture to separate from the liquid component;

10 (e) depositing the separated solid component around the feed opening in the mixing container; and

(f) feeding the solid-liquid mixture through the feed opening into the receiving container.

15 In addition, according to a specific embodiment of the present invention, the foregoing feed opening may be constituted so that the area of the opening can freely be changed.

#### BRIEF DESCRIPTION OF THE ATTACHED DRAWINGS

20 The present invention will hereunder be described in more detail with reference to the accompanying drawings, in which:

Fig. 1 is a sectional view for illustrating the first embodiment of the apparatus for carrying out the first example of the method of the present invention;

25 Fig. 2 is a sectional view for illustrating a part of the second embodiment of the apparatus used to carry out the second example of the method of the present invention;

Fig. 3 is a sectional view for illustrating a part of the third embodiment of the apparatus used for carrying out the third example of the method according to the present invention;

30 Fig. 4 is a schematic plan view of the apparatus shown in Fig. 3;

Fig. 5 is a sectional view for illustrating the fourth embodiment of the apparatus used for carrying out the fourth example of the method of the present invention;

35 Fig. 6 is a sectional view for illustrating the fifth embodiment of the apparatus used for carrying out the fifth \_\_\_\_\_



example of the method according to the present invention;

Fig. 7 is a sectional view for illustrating the sixth embodiment of the apparatus used for carrying out the sixth example of the method according to the present invention;

5 Fig. 8 is a sectional view for illustrating the ninth embodiment of the apparatus adapted for carrying out the ninth example of the method of the present invention;

Fig. 9 is a graph showing the solid/liquid ratio observed in Test Example 1;

10 Fig. 10 is a graph showing the solid/liquid ratio observed in Test Example 2;

Fig. 11 is a perspective view of the apparatus for feeding solid-liquid mixtures according to the present invention;

15 Fig. 12 is a perspective view of a collecting device used in the present invention;

Figs. 13 to 15 are diagrams for illustrating the functions of the first piston device and the second piston device;

20 Fig. 16 is a schematic plan view of a collecting blade;

Fig. 17 is a side view of a screw type collecting blade;

25 Fig. 18 is a side view of a ribbon-like collecting blade; and

Fig. 19 is a side view of a paddle type collecting blade.

## PREFERRED EMBODIMENTS OF THE INVENTION

The first example of the method of this invention may be carried out using an apparatus shown in Fig. 1 illustrating the first embodiment thereof. As seen from Fig. 1, the apparatus comprises a bell shaped container 1 for mixing a solid-liquid mixture M, a feed and shut-off device 2 for feeding and shutting off the mixture contained in the container 1, which is disposed at the bottom of the container 1 and a feed controlling device 4 for adjusting the minimal sectional area of the path for feeding the mixture M therethrough and disposed below the feed and shut-off device 2, the feed controlling device 4 being connected to a known filling device 6. In this embodiment, the internal surface of the mixing container 1 is constituted by a part of a spheric surface, however, it is also possible to constitute the surface thereof by a member in the form of a reversed truncated cone provided with a feed and shut-off device 2 at its bottom.

The feed and shut-off device 2 comprises a shut-off plate 10 which is inserted in and withdrawn from a feed path 12. The feed controlling device 4 is constructed so that a plurality of plates 16 each having a through hole 14 of a different size, which are previously prepared, can be selectively inserted into the feed path 12 from one side of the feed path.

Using such an apparatus of the foregoing construction, a liquid component 20 is mixed with a solid component 22 of a specific gravity greater than that of the liquid in the

5 mixing container and the solid component 22 is deposited on the bottom of the mixing container. At this stage, the shut-off plate 10 is withdrawn from the feed path 12 while inserting a selected plate 16 having an opening 14 of a desired size into the feed path 12. Thus, the liquid component 20 and the solid component 22 deposited on the bottom of the container 1 are transferred to a filling or dispensing device 6 through the feed path 12 while maintaining a desired mixing ratio of the mixture.

10 Other examples of the method according to the present invention will hereunder be explained. However, these examples are explained simply on the basis of the mixing container 1 and the feed controlling device, and the explanation and the diagrammatic representation of the feed and shut-off device 2 and the filling or dispensing device 6 which are common to the apparatus shown in Fig. 1 and other apparatuses are omitted.

20 The second example of the method according to the present invention may effectively be carried out utilizing an apparatus shown in Fig. 2. In this apparatus, a feed controlling device 30 is constructed so that the feed amount and the mixing ratio of the mixture M can be controlled by adjusting the position of the feed controlling plate 32 to be inserted into the feed path 12. The insertion of the feed controlling plate 32 into the path is achieved by the reciprocating motion or the rotational motion of the feed controlling plate 32 within a plane perpendicular to the

25

feed path 12.

5 The third example of the method according to the present invention may likewise effectively be carried out utilizing an apparatus shown in Figs. 3 and 4. In this apparatus, the feed controlling device 40 comprises a revolver 44 having a plurality of through holes 42 of different diameters, formed on the same circumference thereof and provided with a handle 46. In this respect, any one of the circular holes 42 may selectively be located within the feed path 12 by rotating the handle 46.

10 The fourth example of the method according to the present invention may effectively be carried out using an apparatus shown in Fig. 5. In this apparatus, the feed controlling device 51 is constructed so that a plurality of plates 52 previously prepared, each having a through hole 50 of a different area, may selectively be inserted into the feed path 12 from the side of the mixing container 1. In this apparatus, it is desirable that the feed and shut-off device be placed below the feed controlling device 51.

15 20 The fifth example of the method according to the present invention may be carried out using an apparatus shown in Fig. 6, wherein the feed controlling device 61 is provided with a plurality of plates 62 each having a through hole 60 of a different area, as in the apparatus used in the fourth embodiment. The plates having through holes are arranged at the side of the feed path 12 while they are superposed on one another and are constructed so that any one of them can be selectively inserted into the

feed path 12.

5 The sixth example of the method according to the invention may be carried out utilizing an apparatus shown in Fig. 7, wherein the feed controlling device 71 comprises a cylindrical member 70 having a plurality of circular through holes 72, each being perpendicular to the axial line 73 of the cylindrical member and which are formed within the same cross-section thereof. The cylindrical member is engaged with the feed path 12 so as to be able to freely rotate around the axial line 73. In this embodiment, the minimal cross section of the feed path 12 is determined by selecting any particular through hole 72 and arranging it so as to be parallel to the feed path 12.

10 The seventh example of the method according to the present invention may effectively be carried out with an apparatus in which the feed controlling device comprises a flexible tube constituting a part of the feed path and a variable clamping device disposed outside the flexible tube. In this embodiment, the mixing ratio of the mixture is controlled and/or adjusted by changing the size of the minimal cross section of the flexible tube for feeding the mixture therethrough, which is effected by operating the variable clamping device.

15 The eighth example of the method according to the present invention may be carried out with an apparatus wherein the feed controlling device comprises a variable throttling device like an aris located within the feed path.

If the variable throttling device is one capable of complete shut-off of the feed path, the use of the feed and shut-off device may be omitted. In this embodiment, the mixing ratio may be controlled by adjusting the degree of throttling of the variable throttling device.

The ninth example of the method according to the present invention may effectively be carried out with an apparatus shown in Fig. 8 wherein a cylindrical container 100 is installed horizontally. In this apparatus, there are disposed, on the upper side thereof, a solid-liquid inlet opening 102 for introducing a solid-liquid mixture into the cylindrical container 100 and a sight through window 104 for observing the interior of the container 100. On the other hand, there is disposed, on the lower side thereof, a solid-liquid outlet opening 106 for transferring the mixture, the outlet opening being communicated to the feed controlling device (not shown). Within the container 100, a rotary shaft 108 having an axis coincide with the axial line of the mixing container is placed and two groups of collecting blades 110 and 112, each comprising two blades, are disposed around the shaft symmetrically with respect to the center of the solid-liquid outlet opening 106. A collecting device 114 comprised of the rotary shaft 108 and the collecting blades 110 and 112 fixed around the shaft is rotated at a relatively low speed by the action of a driving device (not shown) and thus the solid component of the mixture deposited on the bottom of the container can be moved along the bottom surface of the container without any



the same manner as in Fig. 9.

The apparatuses for feeding a solid-liquid mixture to a filling device according to the present invention will hereunder be explained in more detail with reference to the accompanying drawings, Figs. 11 to 19. In this respect, it should be noted that the apparatuses shown in Figs. 1 to 8 and explained above associated with the examples of the method of this invention are also the very embodiments of the apparatus according to the present invention.

The first embodiment of the apparatus according to the present invention comprises, as shown in Fig. 11, a mixing container 202 of approximately cylindrical shape, a chute member 204 mounted on a feed opening 203 portion disposed on the bottom of the mixing container 202, a first piston device 206 connected to the lower portion of the chute member 204, a second piston device 208 connected to the first piston device 206 at its one side and a filling or dispensing device 210.

The mixing container 202 is provided with, on the top thereof, a level gage 222 for determining the height of the liquid level of the solid-liquid mixture in the container and a sight through window 224 for observing the interior of the container therethrough, and, on the upper side thereof, a tube 226 for feeding the solid-liquid mixture into the mixing container.

As shown in Figs. 11 and 12, a collecting device 230 is installed within the mixing container 202 and the device

comprises a shaft member 229 on which four collecting blades 228 are disposed and planted perpendicular to the cylindrical side of the member. The shaft member 229 has an axis in common with the mixing container 202 and is disposed within the container in a freely rotatable manner, which is rotated by the operation of a driving device (not shown). The collecting blades 228 are divided into two groups each comprising two blades and these two groups of collecting blades are mounted on the shaft symmetrically with respect to the feed opening 203 so as to form spirals having orientations opposite to one another.

Each collecting blade 228, as shown in Fig. 16, is mounted on the shaft member 229 so as to satisfy the following requirement:

$$0^\circ < \theta < 90^\circ$$

wherein  $\theta$  is an angle made between the axial line L and each one of the collecting blades 228 interested, in the anticlockwise direction with respect to the axial line L of the shaft member 229 when observing them just above the shaft member 229 in the hypothesis that the shaft member 229 is rotated in the clockwise direction upon observing it from the side of the feed opening 203 and the collecting blades 228 are situated just below the shaft member 229. The solid component of the mixture is gradually moved along the bottom surface of the mixing container 202 and transferred towards the feed opening 203 by arranging the collecting blades 228 in such a manner as described above.

As desired examples for the construction of the

collecting blades 228, there may be mentioned such a screw  
type one as shown in Fig. 17, such a ribbon type one as  
shown in Fig. 18 and such a paddle type one as shown in Fig.  
19. The screw type collecting blade provides various  
5 advantages such that it can transfer the solid component to  
the filling device even if the rotational speed is  
substantially low and that it is possible to restrict the  
occurrence of the damages of the solid component since the  
blades, in this case, is comprised of a continuous one. If a  
10 ribbon type or paddle type collecting blade is used, it is  
required to increase the rotational speed thereof in order  
to achieve a desired movement or transfer of the solid  
component, however, these types of blades exhibit advantages  
that they may easily be processed to desired shapes and  
15 thus the manufacturing cost thereof is quite low. In the  
embodiment shown in Fig. 12, the collecting blades 228 are  
arranged along a spiral locus at equal intervals and thus  
they make it possible to transfer the solid component at an  
equal speed over the whole portion of the mixing container  
20 202.

Moreover, it is desirable that the collecting blades  
228 should not be mounted on the upper portion of the feed  
opening 203. This is because the deposits of the solid  
component are disturbed in the vicinity of the feed opening  
25 203 due to the rotation of the collecting blades 228 and  
thus becomes unstable. However, if the chute member 204 of  
relatively depth is used, it is not necessary to restrict

the region at which the collecting blades 228 are disposed since the solid components are always deposited on the chute member 204 stably.

5 The radius of the collecting blades 228 are determined so that the distance between the apex thereof and the internal surface of the mixing container 202 becomes as close as possible. This is required for preventing the fail of collection of the solid component by the collecting device 230.

10 The chute member 204 is in general formed in a cylindrical shape or a funnel like shape and it may integrally be formed together with the mixing container 202 as a part thereof. Furthermore, the collecting blades 228 are mounted on the shaft member 229 approximately  
15 perpendicular with respect to the latter and, therefore, the solid component is not paddled, by the collecting blades 228, towards the upper portion of the mixing container 202 and in turn the solid component is not damaged and destroyed due to the collisions therebetween.

20 The first piston device 206 comprises, as shown in Figs. 13 to 15, a device 242 for switching flow paths and a first piston 244 provided with a first piston member 243. The flow path switching device 242 is provided with inlet portion 240, a piston communicating portion 246 and a  
25 delivery portion 248, and there is disposed a switching member 250 at the communicating portion common to these three portions. The switching member 250 may be located at either the position at which the inlet portion 240 and the

piston communicating portion 246 are communicated to one another, as shown in Fig. 13; or the position at which the piston communicating portion 246 and the delivery portion 248 are communicated to one another as shown in Figs. 14 and 15.

The second piston device 208 comprises a cylinder 260 provided with a tube 262 for communicating the cylinder with the delivery portion 248 of the first piston device 206. The position at which the communicating tube 262 is connected to the cylinder 260 is determined so that the communicating tube 262 is opened to communicate the tube 262 with a filling device 210 when the second piston member 264 is situated at the upper portion as shown in Fig. 14 and that, on the other hand, it is closed when the second piston member 264 is situated at the lower portion as shown in Figs. 13 and 15.

The filling device 210 fills, into packing bags 270, a desired amount of the solid-liquid mixture transferred from the second piston device 208 and then seals the opening 272 of the packing bag for finishing a cycle of the packing operation of the mixture.

Then, the function of the apparatus for supplying solid-liquid mixture having the foregoing construction will hereunder be explained. The solid-liquid mixture is introduced into the mixing container 202 through a tube 226 for filling the same. In the mixing container 2, the shaft member 229 is rotated at a relatively low speed to collect

the solid material around the inlet portion of the chute member 204 and to deposit the solid material within the chute member 204. The rotational speed is determined so that the solid material is not flew about from the bottom of the container by the rotation of the shaft member 229 and it is slowly moved along the bottom surface and transferred towards the chute member 204.

On the other hand, as shown in Fig. 13, the piston member 243 of the first piston device 206 is moved back so that the inlet portion 240 and the piston communicating portion 246 are communicated to one another and a desired volume for receiving the material is assured, thereby the solid-liquid mixture being filled therein.

Subsequently, the switching member 250 is rotated so as to communicate the piston communicating portion 246 and the delivery portion 248, as shown in Fig. 14 and thus the first piston member 243 advances to transfer, under pressure, the solid-liquid mixture present in the first piston device 206 to the second piston device 208.

In the second piston device 208, as shown in Fig. 14, the second piston member 264 ascends to communicate the communicating pipe 262 with the packing bag 270 and thus a part of the solid-liquid mixture is packed into the packing bag 270. Then, the second piston member 264 descends so that the solid-liquid mixture present in the second piston device 208 is further packed in the packing bag 270 until a desired amount of the mixture is finally filled therein.

The aforementioned operations of the first and second

piston devices 206 and 208 are repeated and on the other hand, the packing bags 270 are also continuously supplied one by one thereby the filling of the mixture into the packing bags being continuously effected.

5 In the embodiment of the apparatus having the foregoing construction, the adjustment of the mixing ratio of the solid-liquid mixture can be effected by selectively placing, between the chute member 204 and the inlet portion 240 in the device for switching the flow paths, a throttling plate selected from those having various openings of different sizes. Moreover, the adjustment of the mixing ratio of the solid-liquid mixture may also be effected by changing the cross-section of the flow path of the chute member 204, through which the solid material is transferred, or that of the opening 203 for feeding.

10  
15  
20  
25 Thus, according to the method of the present invention which comprises, as explained above, introducing a solid-liquid mixture into a mixing container, depositing the solid component of the mixture around an opening for feeding mixture, disposed on the bottom portion of the container and feeding the mixture through the opening, it is possible to change the mixing ratio of the resultant mixture by adjusting the area of the opening for feeding. Therefore, the method according to the present invention exhibits a variety of advantages such that the construction thereof is very simple, the solid component is not damaged and destroyed and a desired and constant mixing ratio can

certainly be maintained.

In addition, the apparatus according to the present invention makes it possible to feed the solid component deposited around the opening for feeding together with the liquid component in a desired constant mixing ratio, this is because the apparatus according to the present invention makes it possible to adjust the mixing ratio of the mixture by simply changing the cross-section of the flow path at any positions from the opening for feeding to the chute member.

THE CLAIMS DEFINING THE INVENTION ARE AS FOLLOWS:

1. A method for feeding a solid-liquid mixture comprising at least  
5 one liquid component and at least one solid component having a  
specific gravity greater than that of the liquid component into a receiving  
container, comprising the steps of:
- (a) providing a mixing container having a feed opening at the  
bottom thereof;
  - 10 (b) providing a receiving container in fluid communication with  
the feed opening the mixing container;
  - (c) introducing the solid-liquid mixture into the mixing  
container;
  - (d) allowing the solid component of the solid-liquid mixture to  
15 separate from the liquid component;
  - (e) depositing the separated solid component around the feed  
opening in the mixing container; and
  - (f) feeding the solid-liquid mixture through the feed opening  
into the receiving container.
- 20
2. A method according to claim 1 wherein the feeding of the solid-  
liquid mixture is effected while adjusting the mixing ratio of the mixture  
by changing the area of the opening for feeding.
- 25
3. A method according to claim 1 wherein the feeding of the solid-  
liquid mixture is carried out at a constant mixing ratio which is adjusted  
by changing the minimum cross-section of the feeding path  
communicated with the opening for feeding.
- 30
4. An apparatus for feeding a solid-liquid mixture comprising at  
least one liquid component and at least one solid component having a  
specific gravity greater than that of the liquid component in a desired  
and constant mixing ratio, comprising:
- a mixing container having a bottom and a feed opening  
35 disposed at said bottom thereof;



a feed-controlling device disposed in the vicinity of said feed opening;

rotatable collecting means disposed in said mixing container for  
5 collecting the solid component of the mixture around said feed opening;  
and

drive means for rotating said collecting means at a speed of  
sufficient slowness that the solid component of the mixture is not  
propelled up from said bottom of said mixing container by the rotation of  
10 said collecting means, wherein the solid component is allowed to  
separate from the liquid component and is deposited at said bottom of  
said container.

5. An apparatus according to claim 4 wherein the opening for  
15 feeding is designed so as to be able to change the area thereof.

6. An apparatus according to claim 4 wherein the opening is  
provided with a chute member for depositing the solid component,  
which is communicated with the opening for feeding.

20 7. An apparatus according to claim 6 wherein the chute member is  
designed so as to be able to change the cross-section of the opening  
thereof.

25 8. An apparatus according to claim 4 wherein the collecting device  
is provided with collecting blades.

9. An apparatus according to claim 8 wherein the collecting  
blades are arranged on a shaft so as to make an angle of  $0^{\circ}$  to  $90^{\circ}$   
30 between the axis of the shaft and each one of the collecting blades in  
the anticlockwise direction with respect to the axis of the shaft when  
observing them just above the member in the hypothesis that the  
shaft member is rotated in the clockwise direction upon observing from  
the side of the feed opening and that the collecting blades are situated  
35 just below the shaft.



10. An apparatus according to claim 8 wherein the collecting blades are in the form of screws.

5

11. An apparatus according to claim 8 wherein the collecting blades are in the form of ribbons.

12. An apparatus according to claim 8 wherein the collecting blades are in the form of paddles.

10

13. An apparatus according to claim 8 wherein the collecting blades are disposed in the regions except for that just above the opening for feeding.

15

14. Apparatus for feeding a solid-liquid mixture substantially as hereinbefore described with reference to and as illustrated in the accompanying drawings.

20 Dated this 4th day of January 1990

HOUSE FOOD INDUSTRIAL COMPANY LIMITED  
By their Patent Attorneys  
COLLISON & CO

25

*Collison*

30



FIG. 1

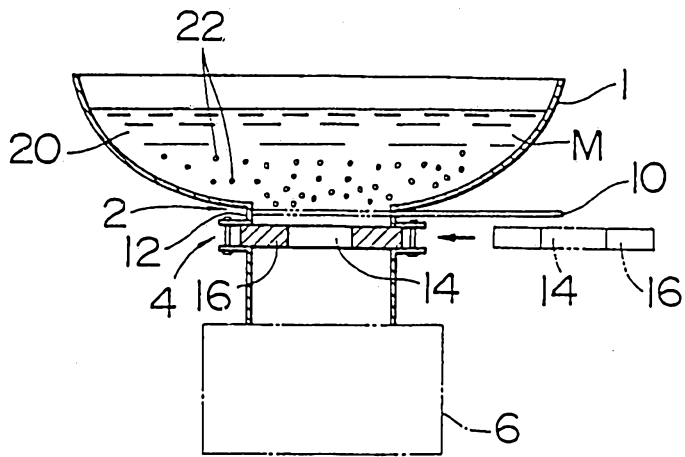
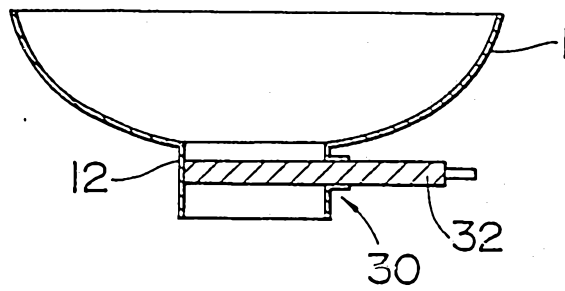

FIG. 2



81890/87

FIG. 3

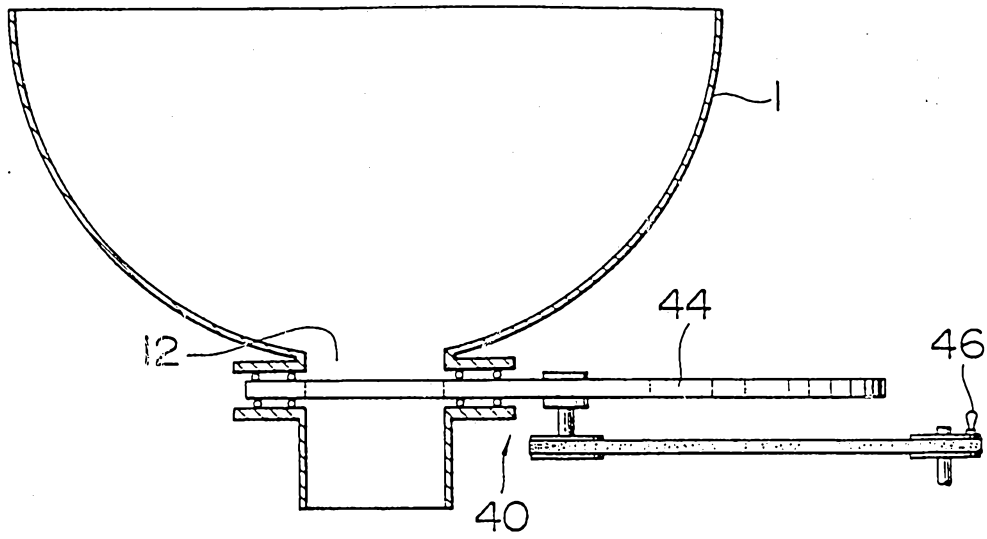
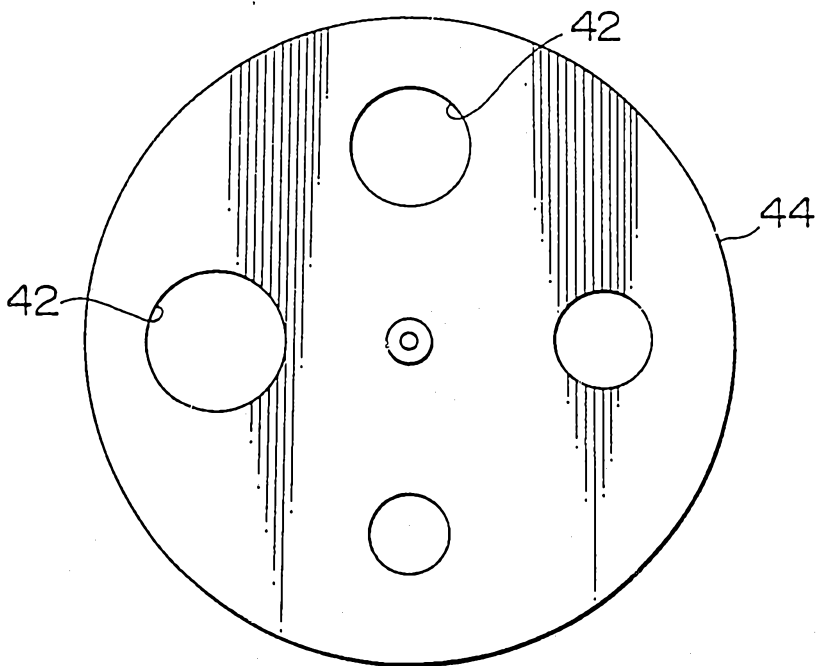

FIG. 4



81890/87

FIG. 5

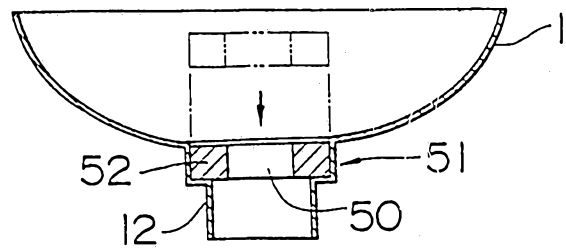

FIG. 6

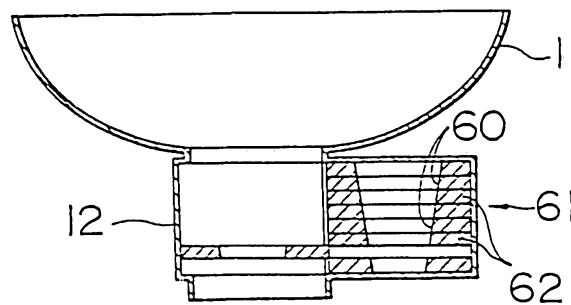

FIG. 7

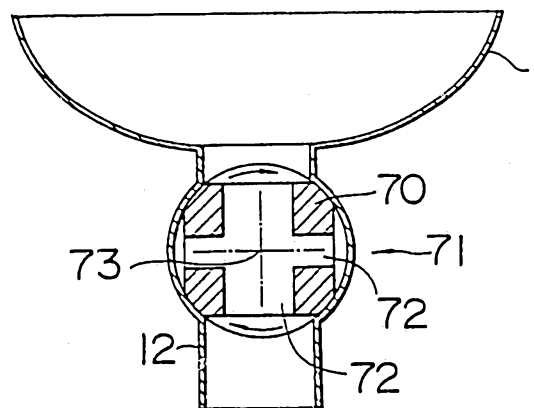

FIG. 8

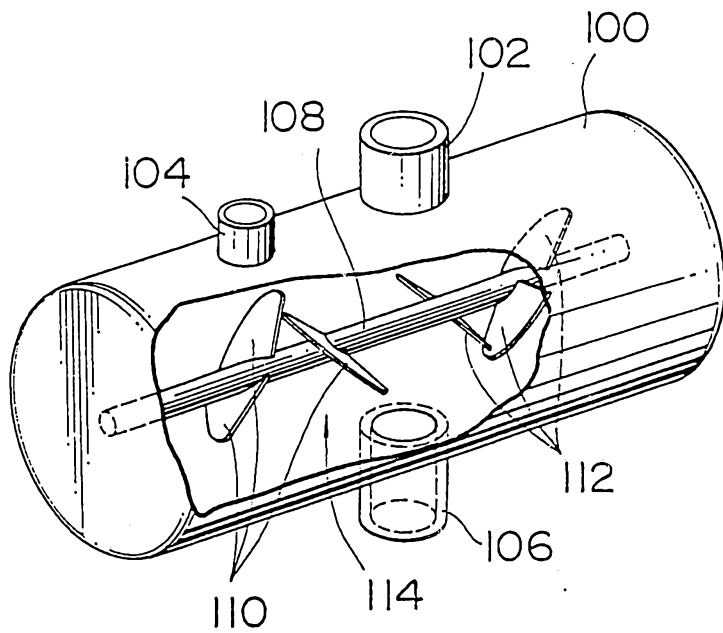

FIG. 9

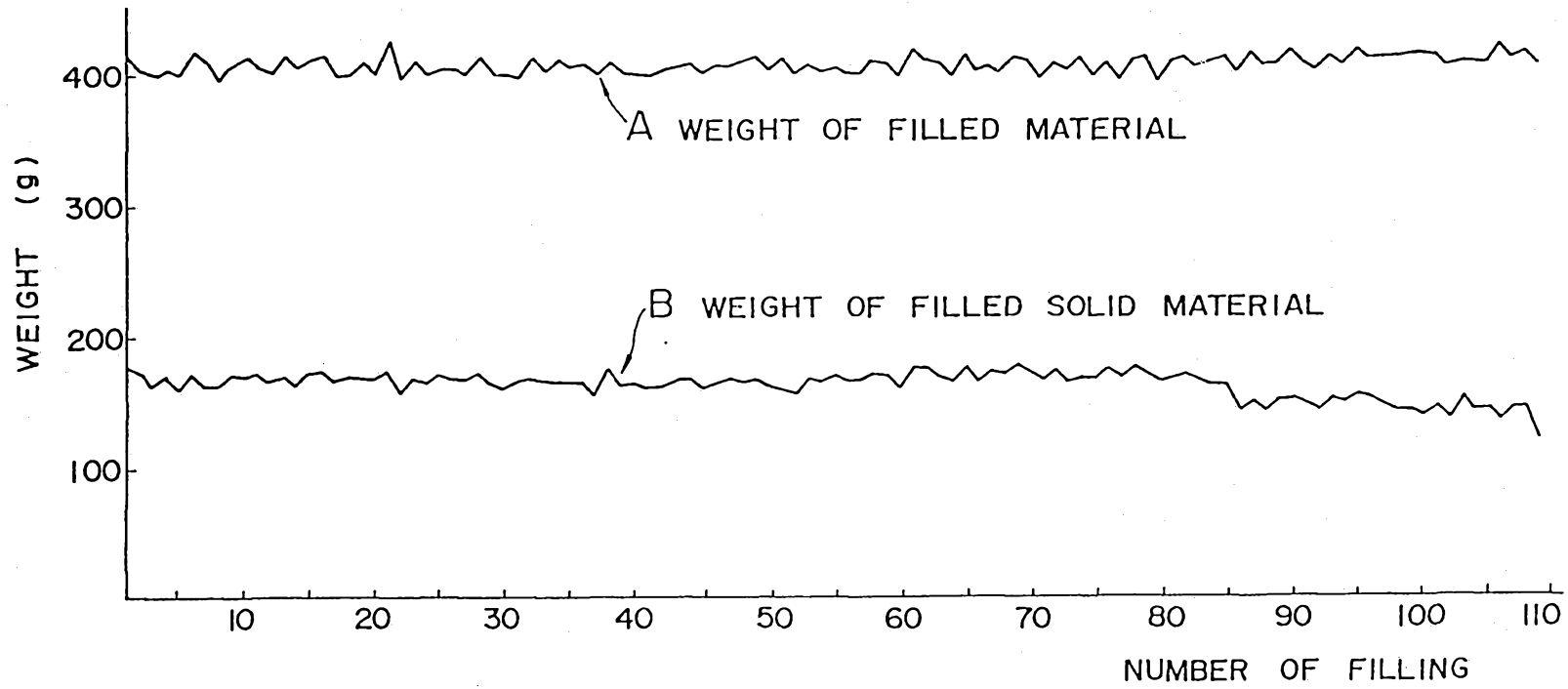

FIG. 10

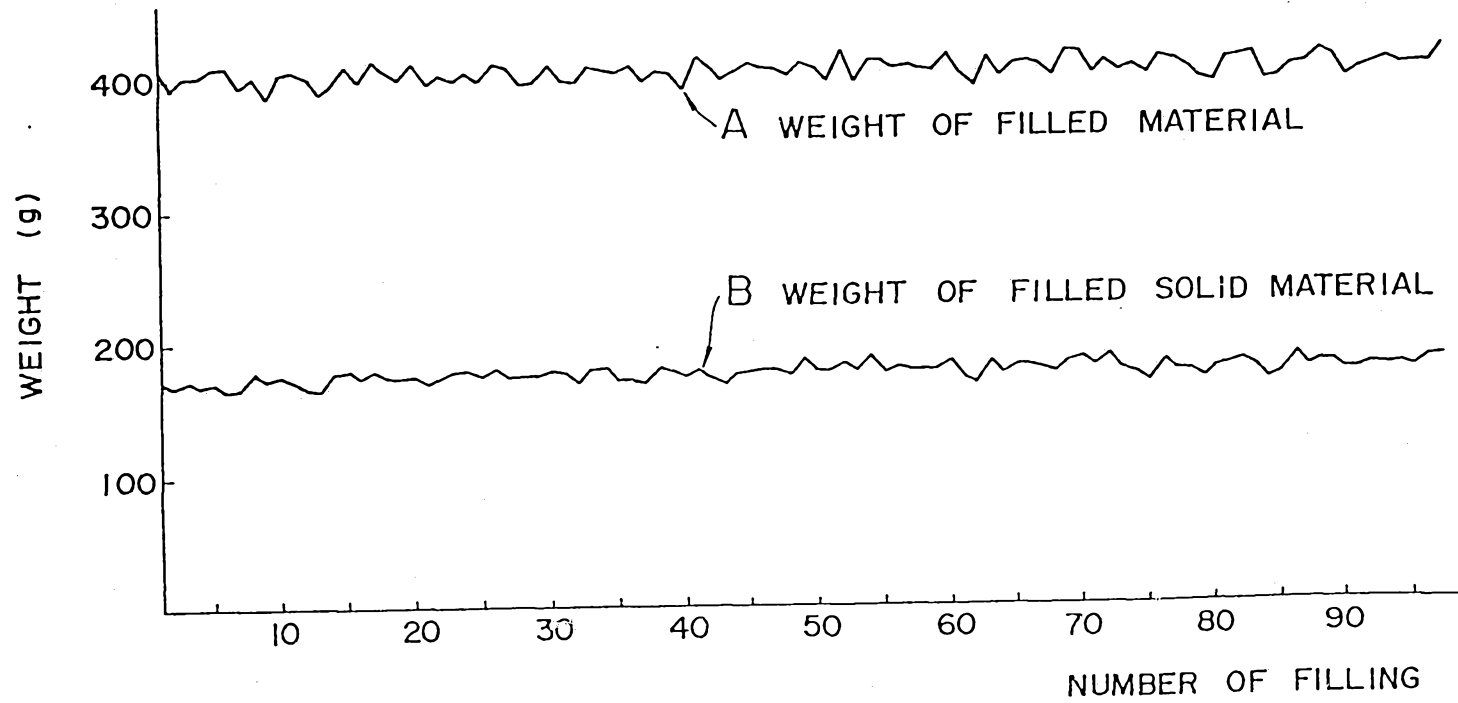

FIG. 11

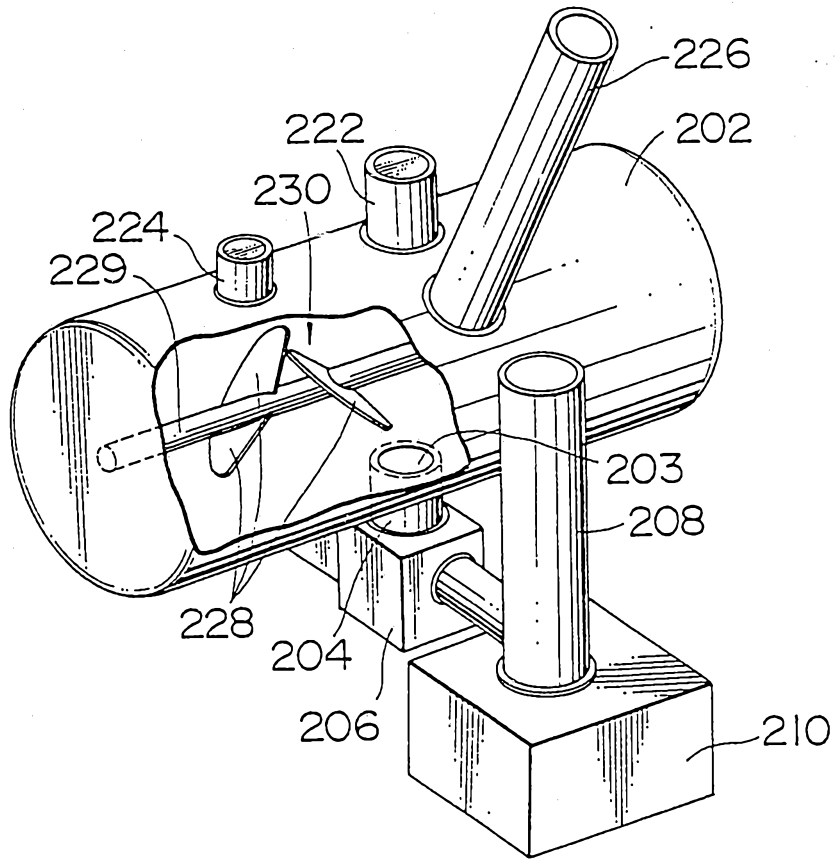

FIG. 12

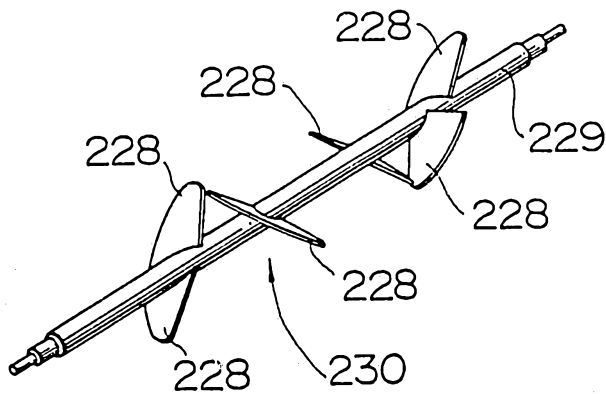

FIG. 13

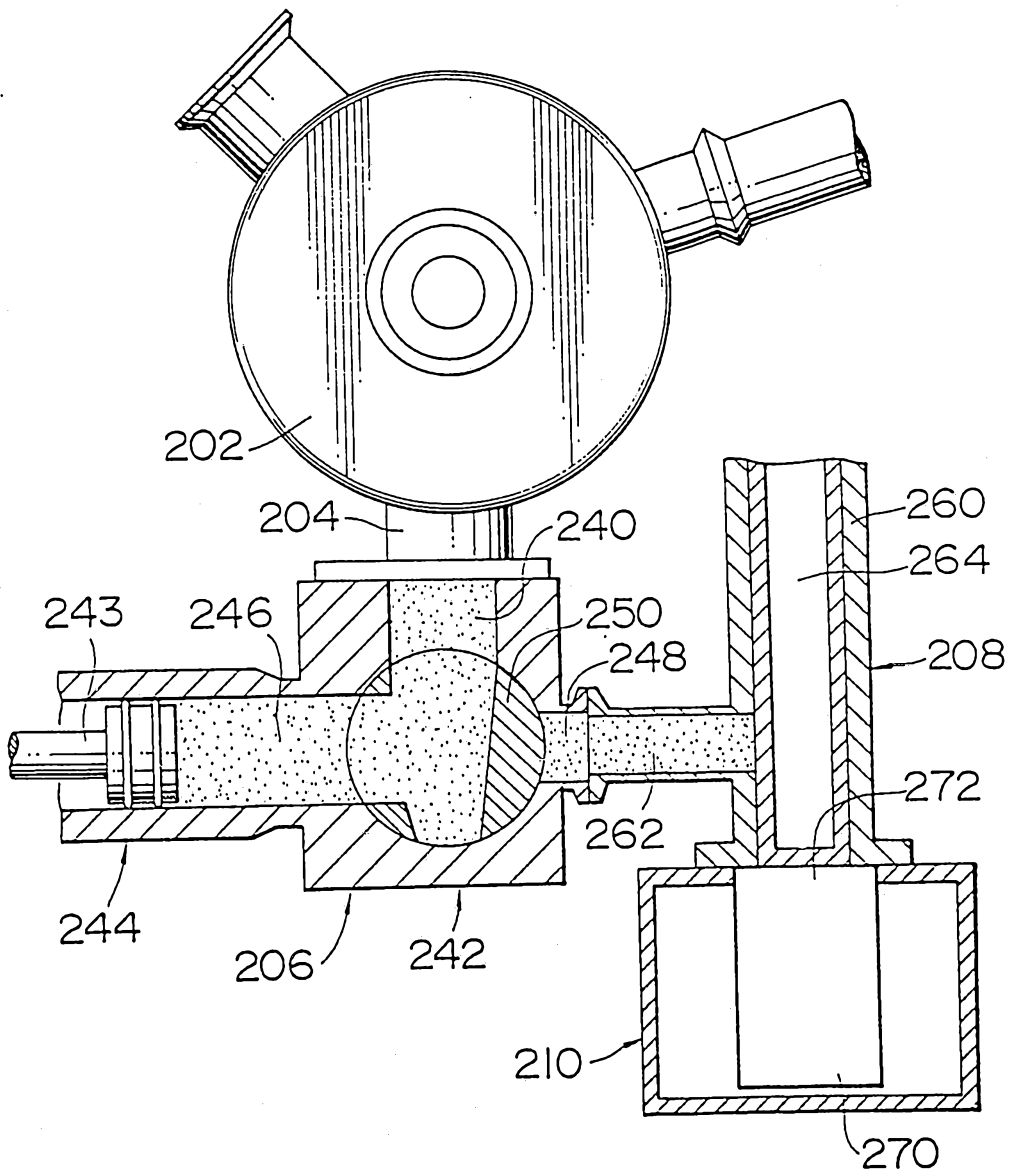

FIG. 14

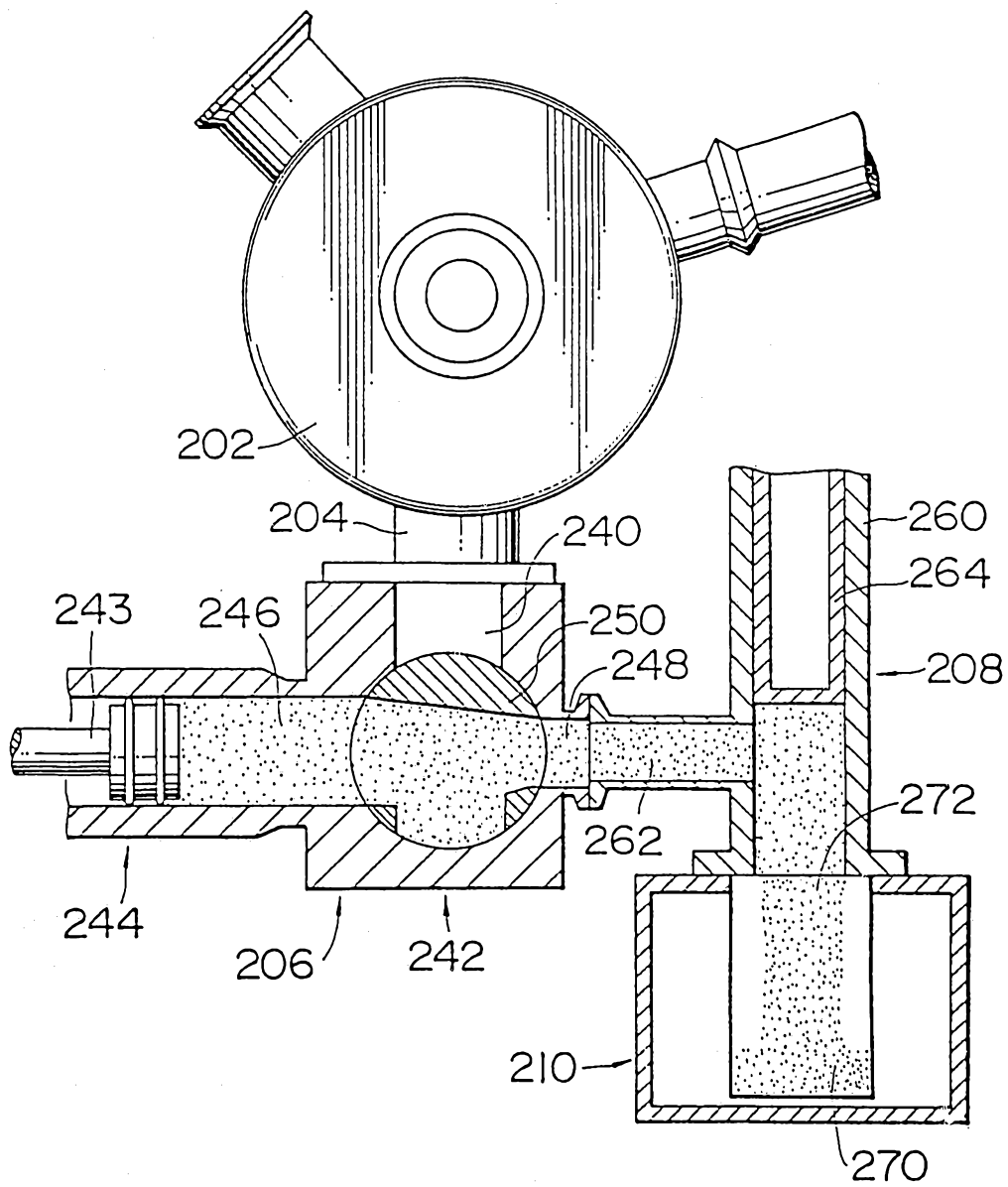

FIG. 15

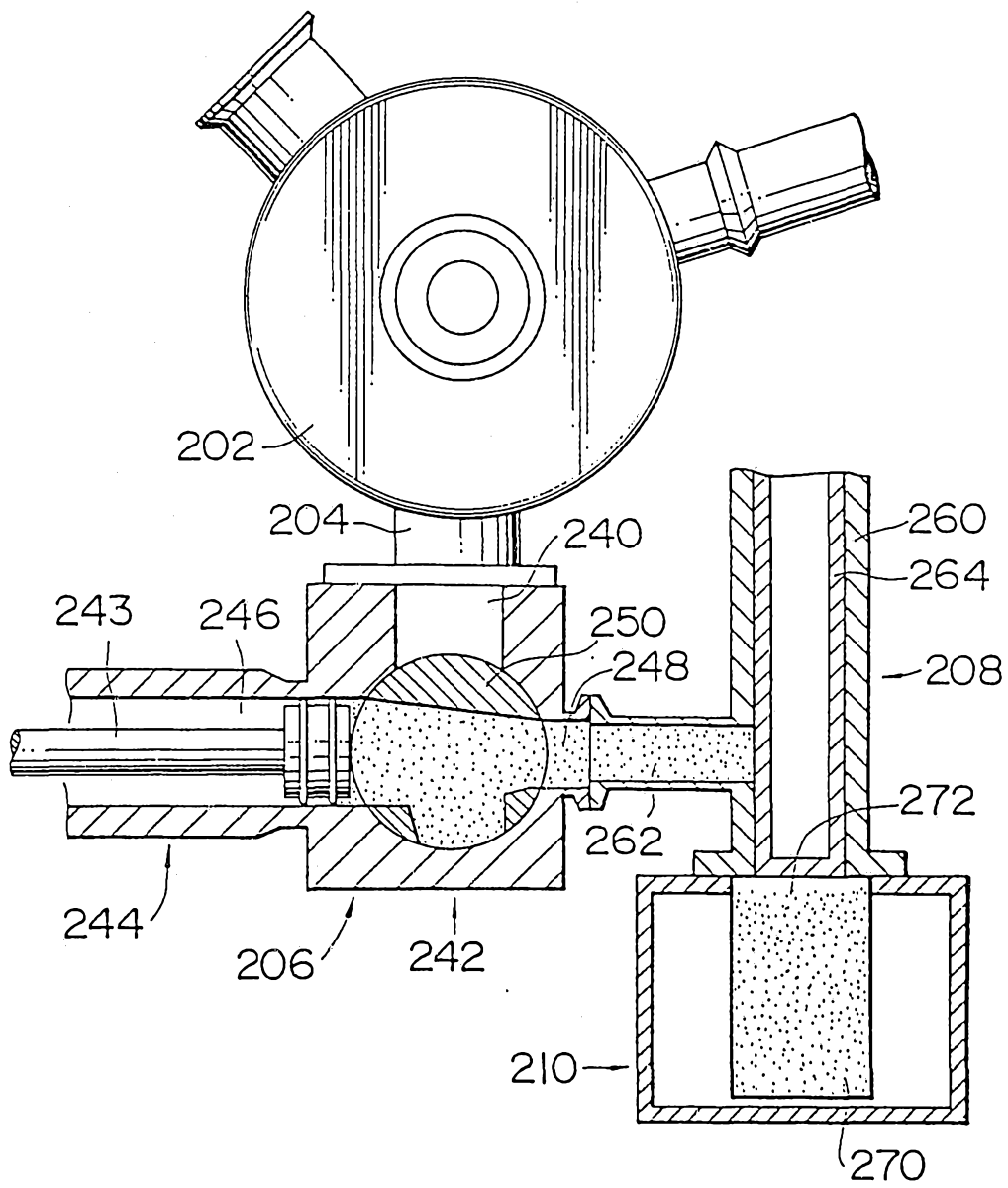

FIG. 16

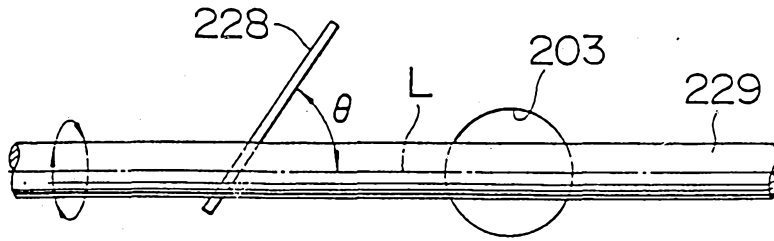

FIG. 17

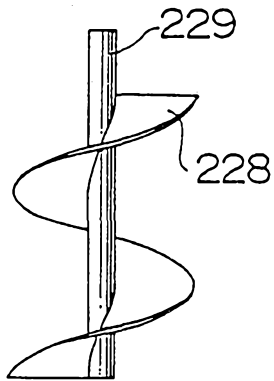

FIG. 18

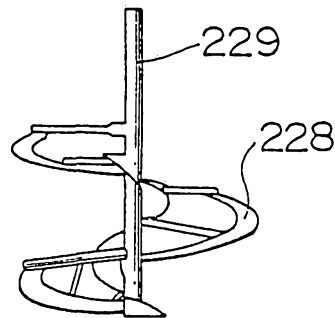

FIG. 19

