

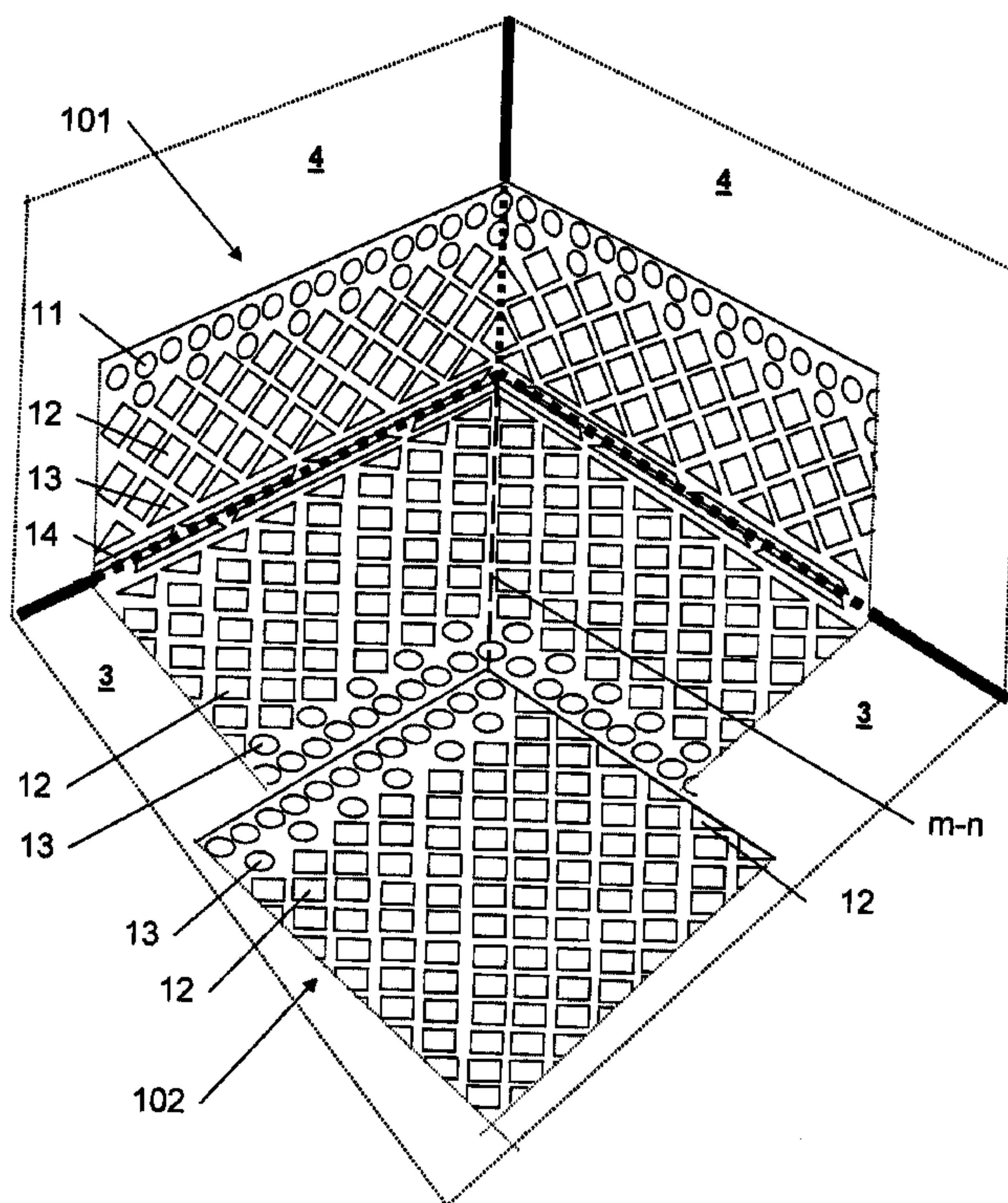

(22) Date de dépôt/Filing Date: 2005/04/14  
 (41) Mise à la disp. pub./Open to Public Insp.: 2005/10/15  
 (30) Priorité/Priority: 2004/04/15 (20041545) NO

(51) Cl.Int.<sup>7</sup>/Int.Cl.<sup>7</sup> E04F 15/18  
 (71) Demandeur/Applicant:  
 ISOLA AS, NO  
 (72) Inventeur/Inventor:  
 JULTON, SVEIN, NO  
 (74) Agent: KIRBY EADES GALE BAKER

(54) Titre : PLAQUE A SURFACE EN RELIEF AVEC LIGNE DE PLIAGE  
 (54) Title: STUDDED PLATE WITH FOLD LINE



(57) **Abrégé/Abstract:**

The present invention concerns a studded plate (1), comprising a first longitudinal edge (60) and a second longitudinal edge (61) between which edges is arranged a main area (90) in the longitudinal direction of the plate (1) comprising a first type of studs (12), characterized in that the main area (90) comprises at least one sub area (100), in the longitudinal direction of the plate (1), comprising at least one first row of a second type of studs (14, 114, 214) which have an oblong shape in the longitudinal direction of the plate (1) and at least one adjacent longitudinal row of a similar stud (14) and/or a third type of studs (13, 113, 213) comprising a longitudinal adjacent border to the first row of studs (12), wherein studs (14) in the first row are offset in the longitudinal direction in relation to the studs in the adjacent row(s).

**Abstract**

The present invention concerns a studded plate (1), comprising a first longitudinal edge (60) and a second longitudinal edge (61) between which edges is arranged a main area (90) in the longitudinal direction of the plate (1) comprising a first type of studs (12), characterized in that the main area (90) comprises at least one sub area (100), in the longitudinal direction of the plate (1), comprising at least one first row of a second type of studs (14, 114, 214) which have an oblong shape in the longitudinal direction of the plate (1) and at least one adjacent longitudinal row of a similar stud (14) and/or a third type of studs (13, 113, 213) comprising a longitudinal adjacent border to the first row of studs (12), wherein studs (14) in the first row are offset in the longitudinal direction in relation to the studs in the adjacent row(s).

**STUDED PLATE WITH FOLD LINE****Area of the Invention**

The present invention concerns a studded plate, such as a plate of a film like material, for use as a support against  
5 floors, walls, ceilings and roofs, and especially as a support for flooring on concrete floors with tiles, floor covering or wooden floors. The invention also concerns the use of the studded plate and a method of placement of the plate.

**10 Technical Background**

Many different types of studded plates which may be used as supporting plates are known. They may be used as ordinary supporting plates, drainage plates, decoupling plates, or plaster plates for plastering or support for adhesive for  
15 tiles for example when flooring with ceramic tiles.

All concrete floors resting on the ground contain moisture. Floor coverings such as wooden floors can therefore not be placed directly on the concrete. Many years may be needed to dry out a concrete floor placed on the ground. The floor  
20 may also be affected by rising damp. Initially, all concrete floors contain residual moisture and the above problem therefore concerns cellars, basement floors, slab on ground floors and floor between different storeys of different types of concrete, including for example floors made  
25 of light expanded clay aggregate concrete and lightweight concrete. The moisture in the concrete is often invisible and difficult to detect. This results in an unawareness of the risks such as rot, moisture damage etc. Without an effective damp proof membrane with sufficient performance  
30 characteristics, moisture from the concrete will for example attack wood materials from underneath. The same problem also concerns tiled floors wherein the filled joints will allow passage of moisture.

The result is damaged floors with cracks, mould and rot. In addition, hazardous mould spores, bad smell and a poor indoor environment may result.

5 The same effect may arise on concrete walls, as in floors, and contain or be affected by rising damp, especially basements with below ground walls.

To solve this problem, studded plates are used for most problems related to moisture in cellars providing "passive" venting towards the room. The studded plates often comprise  
10 hollow studs with circular or rounded cross-section, i.e. the form of the circumference of the studs, with a height from 3 to 5 mm. The studs are often distributed in a diamond pattern or a check-board pattern providing adequate distribution of the loading as well as venting. The studded  
15 plates are placed with the top of the studs facing downwards toward the base floor to obtain an air gap on the underside of the plate, between the studs.

The plates may be joined by sealing tape on the topside of the plates to obtain a sealed floor. In case of severe  
20 problems with moisture, smell or other emissions, the air gap beneath the studded plates may be ventilated mechanically in order to provide air flow over the concrete plate and create a negative pressure in relation to the room. A ventilated air gap may also contribute in the drying out of  
25 the concrete.

Recently, plates have been developed comprising studs with undercuts or overhangs, meaning that the area of the opening of a stud is smaller than the area of the top of the stud, giving a good anchoring of plaster or adhesive, independent of which face the plaster or adhesive is applied.  
30 Such a plate is described in EP 1 068 413 issued on August 10, 2004 to Isola AS for example.

The studs in the above mentioned patent are characterized by a uniform shape of the studs which are distributed on the plate in a repeated pattern. The pattern often allows folding of the plate in the longitudinal and/or transverse direction of the plate, but also in a 45° angle.

However, it is a problem with the above mentioned solution that a plate placed on the floor should be turned up against the wall of the room, in order to guide the humid air out of the air gap. In other words, the air gap must be in contact with the room. In the simplest manner, this is achieved by folding the plate at the transition between the floor and the wall. The problem with this solution is that all the above mentioned plates thereby obtain a folding crease which either inhibits the transport of humid air or for example the plate comes in direct contact with the adhesive used against the floor thereby blocking the air gap.

It is also quite usual to laminate the studded plate with a fabric or a grid on the top of the studs in order to bond the plate temporarily or permanently to the concrete floor, so that the plate is evenly fixed to the substrate during installation of the floor covering or tiles. The fabric, which will be applied with adhesive, will also contribute in blocking the transport of air as it will be stretched against the folding crease of the plate and thereby block the air gap.

One solution to this problem has been to place the plate on the floor at a small distance from the wall and to use a special edge plate which is bonded onto the top face at the edge of the plate on the floor, to finish the venting towards the room. However, there is always a risk that plates on the floor are pushed towards the wall and will remain in contact with the wall, or that adhesive is pressed into the junction between the floor and the wall, thereby blocking the venting.

The present invention is aimed at solving the above problems and to provide a plate and a method for placing it so that transport of moisture is secured away from the substrate, such as a floor, in a simple and sure manner.

5 **Brief Description of the Invention**

The present invention concerns a studded plate wherein at least one edge in the longitudinal direction of the plate has a fold line which maintains airflow even when the plate is folded at 90° along the edge. The described studded  
10 plate thereby secures venting and equalization of the water vapour pressure across the floor, as well as reducing the risk of capillary action.

The present invention therefore concerns a studded plate, comprising a first longitudinal edge and a second longitudinal  
15 edge between which are arranged a main area in the longitudinal direction of the plate comprising a first type of studs, wherein the main area comprises at least one sub area, in the longitudinal direction of the plate, with a second type of stud which have an elongated or oblong  
20 shape in the longitudinal direction of the plate and at least one adjacent longitudinal row of a similar stud and/or a third type of stud comprising a longitudinal adjacent border to the first row of studs, wherein studs in the first row are offset in the longitudinal direction in rela-  
25 tion to the studs in the adjacent row(s).

The main advantage with this system is that a whole room may be covered with one type of plate without the need for other specialty plates and parts other than a jointing tape.

**Description of the Drawings**

In order to explain the invention in more detail, basis is made in four embodiments of the invention and the attached drawings wherein:

- 5 Figure 1 shows a perspective view of a studded plate according to a first embodiment of the invention viewed from underneath.

Figure 2 shows a planar view of a studded plate according to a second embodiment viewed from underneath.

- 10 Figure 3 shows two cross sections of the studded plate in figure 2 along the lines A-A and B-B respectively placed against a floor support.

Figure 4 shows the studded plate in figure 2 with an applied fabric.

- 15 Figure 5 shows two cross sections of the studded plate in figure 4 along the lines C-C and D-D respectively placed against a floor support.

- Figure 6 shows two cross sections of the studded plate in figure 4 along the lines C-C and D-D respectively placed in  
20 a folded up state against a supporting floor and wall.

Figure 7 shows an extended planar view of the studded plate in figure 2.

Figure 8 shows a planar view of a studded plate according to a third embodiment viewed from underneath.

- 25 Figure 9 shows a planar view of a studded plate according to a fourth embodiment viewed from underneath.

Figure 10 shows a perspective view of two studded plates arranged in an interior corner against a supporting floor and wall.

### **Detailed Description**

5 The invention will be further described in greater detail by examples of embodiments which are not meant to limit the scope of the invention, which is defined by the attached set of claims only.

10 The present invention is mainly directed at studded plates having studs protruding only on one surface side of the plate. However, plates containing studs protruding on both surface sides of the plate are also contemplated.

In the further description the following terms will be used:

15 "Longitudinal" is assigned to the direction of a sheet of the plate with the largest dimension which may be the production direction and the direction in which the sheet may be rolled up.

20 "Transverse" is assigned to the direction of a sheet of the plate perpendicular to the longitudinal or production direction.

"Longitudinal edge" is assigned to edges of the plate parallel to the longitudinal direction.

25 "Studs" is assigned to the protrusions extending out of the surface of the plate.

"Bottom face" and "underneath" is meant to refer to the face of the plate where the studs protrude out of the surface of plate, the area being uneven according to the shape, number and height of studs in the plate.

"Top face" is meant to refer to the face of the plate normally visible after placing it on a substrate, the area being relatively smooth with hollows leading into the plate.

5 "Channels" are referred to the spaces formed between the studs protruding out on the bottom face of the plate.

"Undercut" or "overhang" refers to studs having non-perpendicular walls in relation to the surface of the plate. In the following embodiments some of the studs have a smaller opening on the top face of the plate, than the top of the stud, giving the stud an undercut or overhang. In the drawings viewed from underneath, this effect may be seen from the dotted lines of the studs representing the opening hole of the stud on the opposite top face of the plate, which may be smaller than the solid lines of the stud, representing the outer circumference of the top of the stud resting against the substrate. The position of the opening of the stud may in addition be different from the position of the top of the stud, giving a larger or lesser degree of overhang in different parts of the stud.

20 A first embodiment of the invention is shown in figure 1, which is a part of a studded plate according to the invention. The plate has a longitudinal direction L and normally such sheets are rolled up in lengths of 20 meters. The plate has a transverse direction W, and the width of a sheet is normally about 1 or 2 meters. The height of the studs in this example is constant at about 3 millimetres, but may be smaller or larger or possibly of varying height.

In the longitudinal direction, the plate is divided in areas of different widths, comprising different types of studs 11, 12, 13 and 14 of different shapes and sizes when following the line a-b. The width of the different areas may vary and the line c-d designates an unidentified width. The line e-f marks an incomplete longitudinal edge as the plate may have different widths, either with the same type

of studs, or other studs as shown on other parts of the plate in figure 1.

As may be seen from figure 1, an edge area of round small studs 11 is present along one longitudinal edge. These studs 11 have a constant circumference in the whole depth of the stud and the diameter in this example is about 8 millimetres. The width of the area may for example be from about 3 to about 5 centimetres.

In the present invention, an improvement of the plate in EP 1 068 413 is used, wherein the longitudinal edges of the sheet includes another type of studs, as given in the Norwegian registered design 77826 and the corresponding US Design no. 29,178/693. The studs 11 in the longitudinal edges have the object of securing that a continuous air gap is maintained in the joining of plates, and of providing extra load bearing strength at the edges and joints of the plates. The circular studs 11 are smaller and differently shaped than the main studs 12, which in this embodiment are square, and are distributed in a pattern providing more channels than the main studs 12. In the jointing with main studs 12, the small studs 11 will secure that the air gap is continuous across the joint and provide relative good transport for moisture being directed across.

The area of small studs 11 borders an area with the mentioned main studs 12. In this example, the studs have a rounded square form and lie in a diagonal pattern in the longitudinal direction L. The main studs 12 contain undercuts by being truncated at the opening in relation to the top of the stud. These overhangs or undercuts may be used to anchor different types of materials such as plaster or adhesives for tiles on either face of the plate. The studs in this example are of a mean width and length of about 1.7 centimetres and the area containing these studs, is from about 8 to 10 centimetres wide. Part studs 13 with a trian-

gular form are placed along the edge of this area of main studs 12.

The next area has oblong studs 14, placed in rows oriented in the longitudinal direction L of the plate 1. These studs  
5 define a fold line of which the centre is indicated by the line k-k in figure 1. The sub area with oblong studs 14 is in this example about 2.5 centimetres wide.

On the other side of the sub area with studs 14, half studs 13 border another area of main studs 12 which continue past  
10 the line e-f. The width of this area with studs 12 is dependant on the width of the plate 1 and constitutes the main part of the plate placed against the floor. This area may be completed with the same type of main studs 12, or preferably an edge area with small round studs 11 for sim-  
15 plifying possible joints against plates that are cut, or to increase the strength.

As may be seen from figure 1, the rows of the oblong studs 14 provide longitudinal channels 21 with transverse openings 20 in-between, the openings 20 being offset in rela-  
20 tion to each other in the longitudinal direction. The channels 21 are especially designed for the folding of the plate, for example at the transition from a floor to a wall. The oblong studs 14 do not contain undercuts in this embodiment.

25 In order to better understand the shape of the studs, a similar second embodiment of a studded plate 1 is shown in figure 2, viewed from the bottom side with two marked sectional lines A-A and B-B. In figure 3 the profiles of cross sections A-A and B-B are represented with the plate is  
30 placed against a substrate 3.

In order to fasten the studded plate to the substrate, it is an advantage, as mentioned initially, to use a fabric or a grid 2 as shown in figure 4 which may be applied to the

studded plate in advance. The top of the studs 11, 12, 13 and 14 in figure 1 are for example provided with a fabric 2 in figure 4 of a suitable material by adhesive or lamination. This fabric 2 may then be used for fixing the plate to the substrate, such as a concrete floor or a wall, either permanently or temporarily. In figure 5 the profiles of the cross sections C-C and D-D are respectively reproduced when the plate 1 with fabric 2 is placed against a floor 3. As may be seen from the figure 5, the offset positioning in the longitudinal direction of the transverse openings 20, always provide at least one oblong stud 14 in the folding line placed against the substrate, in this case the floor.

The latter is important in the folding of the plate 1 with fabric 2, as shown in figure 6 wherein the cross sectional profiles in figure 5 are represented in a folded up state. The plate 1 is placed against a floor 3 and the longitudinal edge of the plate is folded up against a wall 4, and the fabric 2 may be glued to both the floor 3 and the wall 4. From the profile of C-C it may be seen that the fabric 2 is stretched out by the studs 14 and are prevented from contacting the surface of the plate 1 between studs. In this manner the transverse openings 20 are maintained open as shown by profile D-D in the same figure. It is important that neither the width nor the length of the transverse opening 20 is too large so that the fabric 2 may contact the surface of the plate 1 between studs. In this example the width of the opening is about 5 millimetres, and approximately the same width as the oblong stud 14. However the person skilled in the art will be able to determine the suitable width without undue experimentation based on the disclosure of the present invention. It is also important that there are not too many openings 20 and that they are not in the same position in adjacent rows so that there always is one oblong stud 14 stretching the fabric 2 as shown by the profile D-D. A too long unsupported distance for the fabric will result in the fabric contacting the

plate. In this embodiment of the plate, as shown in figure 4-6, the fabric will be stretched out by two rows of oblong studs 14, and thereby secure continuation of the air gap. As mentioned above the person skilled in the art will also be able to determine this feature without undue experimentation based on the present disclosure.

Figure 7 shows a typical width of a plate 1 cut in the transverse direction with edges 50, with longitudinal edges 60 and 61, wherein the main area 90 with square studs 12 is divided by a sub area 100 with oblong studs 14 making up the fold line, and wherein both longitudinal edges of the plate 1 have areas 80 with small round studs 11. The lines 200 and 300 indicate that the width of the main area 90 is not restricted on either side of the sub area 100.

Figure 8 shows a third embodiment of a plate according to the invention comprising a fold line. In this embodiment the main areas comprise two types of studs, such as circular studs 112 and propeller shaped studs 110, both of which have undercuts, although somewhat offset. The fold line is made up of a central longitudinal row of oblong propeller shaped studs 114, and one row on each side, comprising oblong studs 113. As in the embodiments described earlier, this arrangement also secures a continuous air gap when the plate is folded in 90° along the line k-k which is the centre line of the folding crease. A continuous air gap is secured through the combination of channels 120 generally in the transverse direction and channels 121 generally in the longitudinal direction. The staggering of the studs in the three rows of the fold line will also prevent an optional fabric 2 on the bottom side of the plate in blocking the channels.

Similarly Figure 9 shows a fourth embodiment of a plate according to the invention comprising a fold line. In this embodiment the main areas comprise two types of studs, such as a cross shaped stud 210 and a circular stud 212, both of

which have undercuts, although somewhat offset. The fold line is made up of a central row of oblong propeller studs 214, and two adjacent rows, one on each side, comprising jelly baby-shaped studs 213 that are oblong on the side adjacent to the central row of studs 214. As in the embodiments described earlier, this arrangement also secures a continuous air gap when the plate is folded in 90° along the line k-k, which is the centre line of the fold line. The width of the jelly baby-shaped studs 214, has the advantage of preventing adjacent areas to the fold line in bending when the plate is folded. A continuous air gap is secured through channels 220 and channels 221 generally in the longitudinal and transverse directions respectively. The staggering of the studs in the three rows of the fold line also prevents an optional fabric 2 in blocking the channels.

Figure 10 shows a method of placement of a plate according to the invention.

Figure 10 shows how a first plate 101 is placed against an interior corner by making a cut in the main area, of the part of the plate placed against the floor 3, so that the folded up edge follows the wall 4. In this embodiment the main studs 12 have a diagonal pattern making it simple to adapt the plate to an interior corner in a room by cutting the plate in 45° along two edges, in towards the fold line as indicated in figure 2, by cutting lines m and n. The resulting edges will then be laid edge to edge and may be sealed with sealing tape. Another plate may then be placed adjacent to the first plate so that round studs 11 secure a continuous air gap in the joint against the second plate 102.

The result obtained by the use of a plate according to the present invention is a secure and good venting of the floor wherein the plate may be bonded to the floor and/or the wall either temporarily or permanently.

The studded plate is preferably produced in sheets of a plastic or polymer film like material such as for example polypropylene or polyethylene. The fabric or grid material may be comprised of synthetic material such as a polymer  
5 material.

**Claims**

1. A studded plate, comprising a first longitudinal edge and a second longitudinal edge between which edges is  
5 arranged a main area in the longitudinal direction of the plate comprising a first type of studs;

the main area comprising at least one sub area, in the longitudinal direction of the plate, comprising at least one first row of a second type of studs which have an  
10 oblong shape in the longitudinal direction of the plate and having at least one of at least one adjacent longitudinal row of a similar stud and a third type of studs comprising a longitudinal adjacent border to the first row of studs, wherein studs in the first row are offset in the  
15 longitudinal direction in relation to the studs in the adjacent row.

2. The studded plate according to claim 1, wherein the main area further comprises a fourth type of stud of any  
20 shape in addition to the first type of stud.

3. The studded plate according to claim 1 or 2, wherein at least one of the distance between the first row and adjacent rows, and the distance between the oblong studs in  
25 the longitudinal direction is approximately the same as the width of the oblong studs.

4. The studded plate according to any one of the claims 1-3, wherein the oblong studs have one of a rectangular,  
30 triangular, trapezoid and propeller formed shape.

5. The studded plate according to any one of the claims 1-4, wherein the first type of studs in the main area have

an approximately square shape and optionally are placed in a diagonal pattern in relation to the longitudinal direction.

5 6. The studded plate according to any one of the claims 1-5, wherein at least one of the first type of stud and the third type of stud in the main area have undercuts.

10 7. The studded plate according to any one of the claims 1-6, further comprising a longitudinal edge area adjacent to at least one of the first longitudinal edge and the second longitudinal edge of the plate, comprising a type of studs which are smaller in area than the studs in the main area.

15

8. The studded plate according to any one of the claims 1-7, wherein the studs in the edge area have a circular shape and a constant sectional form through the whole depth of the stud.

20

9. The studded plate according to any one of the claims 1-8, wherein the plate is of a synthetic material, the synthetic material being one of a polymer material and a plastic material.

25

10. The studded plate according to any one of claims 1-9, wherein the plate comprises at least one of a grid and a fabric of suitable material fixed to the top of the studs of the plate for ease of attachment of the plate to a  
30 substrate by the use of an adhesive.

11. The studded plate according to claim 10, wherein the grid or fabric is of a synthetic material, the synthetic material being a polymer material.

5 12. The studded plate according to any one of the claims 1-11, wherein the first type of studs in the main area have a width of from 5 to 50 millimeters, and that the second type of studs in the sub area have a width of from 2 to 25 millimeters and a length of from 10 to 100 millimeters, and  
10 that the studs in the edge area have a diameter of from about 3 to about 30 millimeters.

13. The studded plate according to any one of the claims 1-12, wherein the main area has a width of from 5 to 300  
15 centimeters, and that the sub area has a width of from 2 to 10 centimeters, and that the edge area has a width of from 1 to 30 centimeters.

14. The use of a studded plate according to any one of the  
20 claims 1-13 as a damp proof membrane and underlay for plaster, floor covering and tiles for floors, walls, ceiling and roofs.

15. The use of a studded plate according to any one of the  
25 claims 1-13 as a damp proof membrane and underlay for laminate flooring, floor covering, linoleum, wooden floor, parquet and screed of concrete.

16. A method for placement of a studded plate according to  
30 any one of the claims 1-13 as a underlay for flooring, wherein the plate is placed with a fold line in the sub area, with one part of the main area against a wall, and the second part of the main area against the floor.

17. A method for placement of the studded plate according to claim 16 in an interior corner of a room, wherein the part of the main area placed against the wall follows the wall in the corner and that the part of the main area placed against the floor is cut with a suitable cut, the suitable cut being  $90^\circ$  or  $45^\circ$  in relation to the longitudinal direction of the plate, so that the cut edges meet edge to edge on the floor.

Application number: numéro de demande: 2,504,105

Figures: 1

Pages: 1

DRW-IP

Unscannable items  
received with this application  
(Request original documents in File Prep. Section on the 10th Floor)

Documents reçus avec cette demande ne pouvant être balayés  
(Commander les documents originaux dans la section de préparation des dossiers au  
10ième étage)

2/8

**Fig 2**

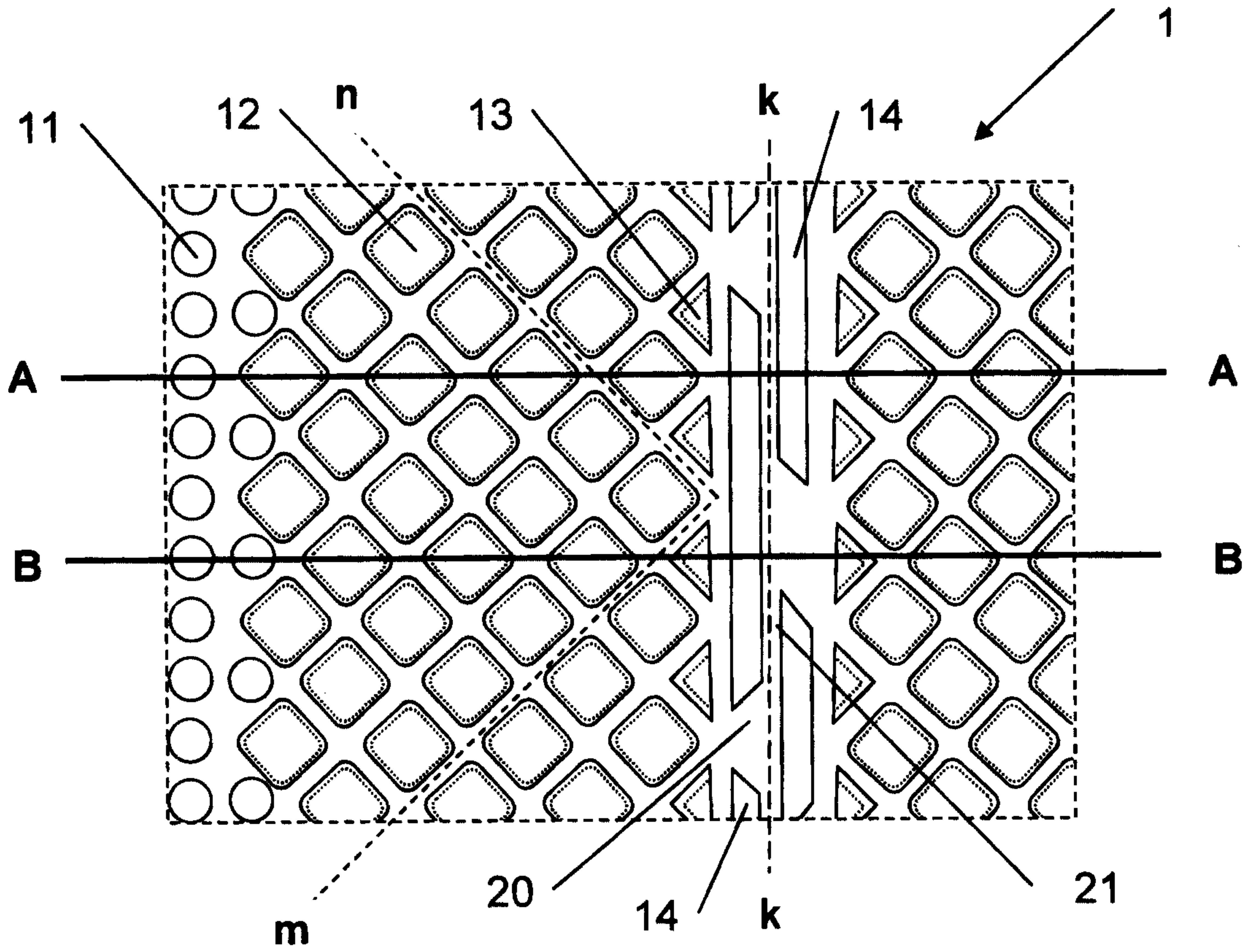

**Fig 3**

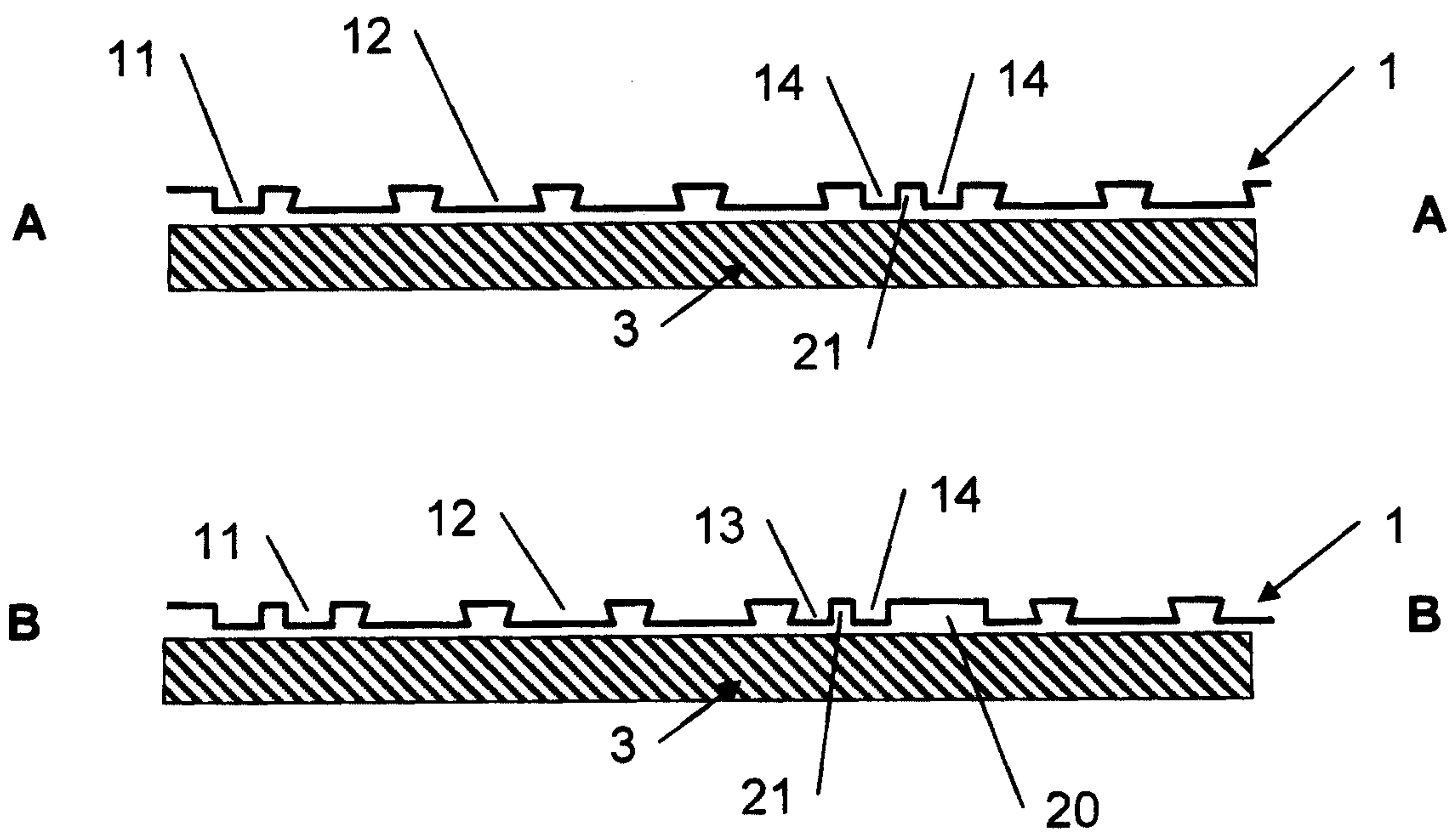

**Fig 4**

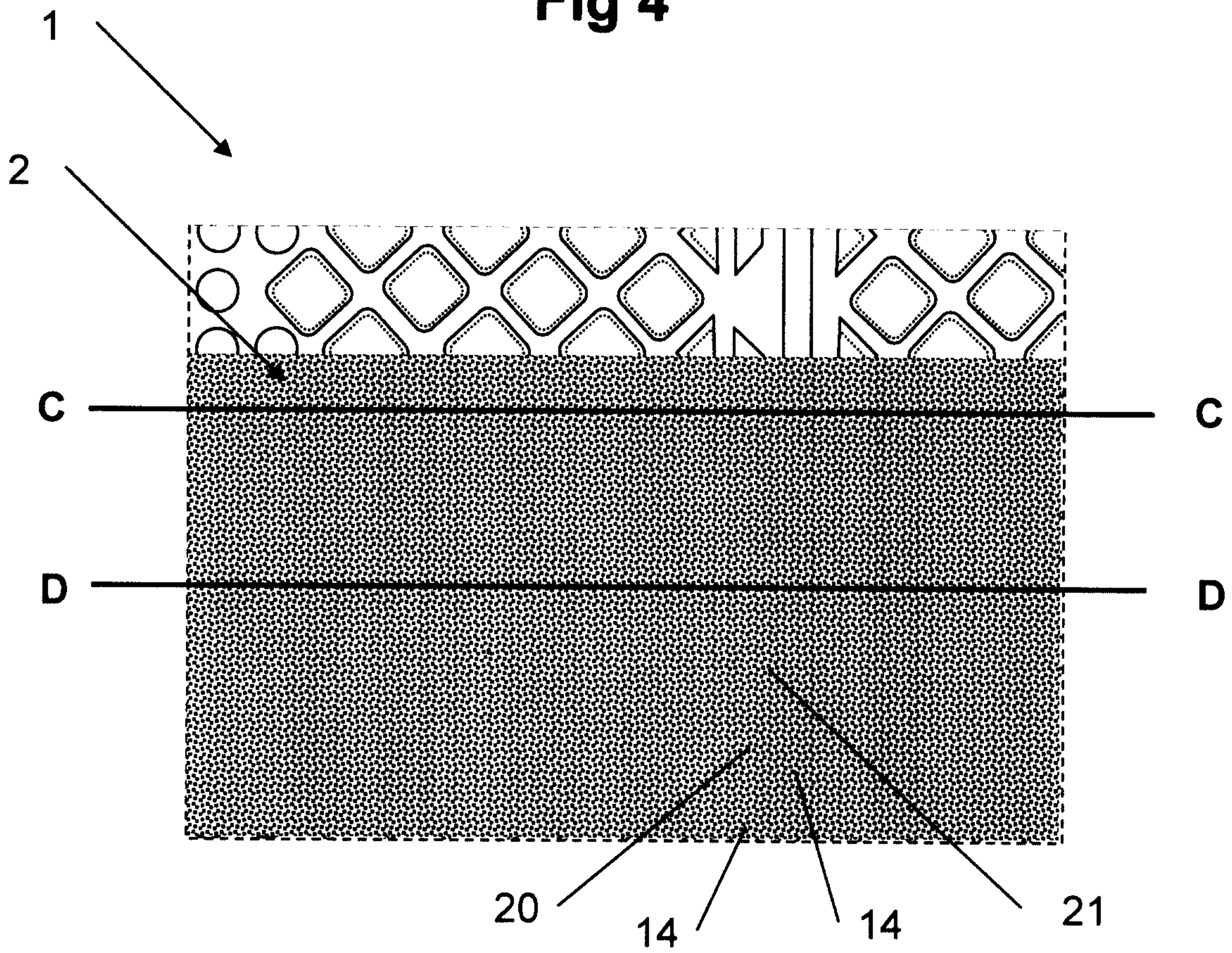

**Fig 5**

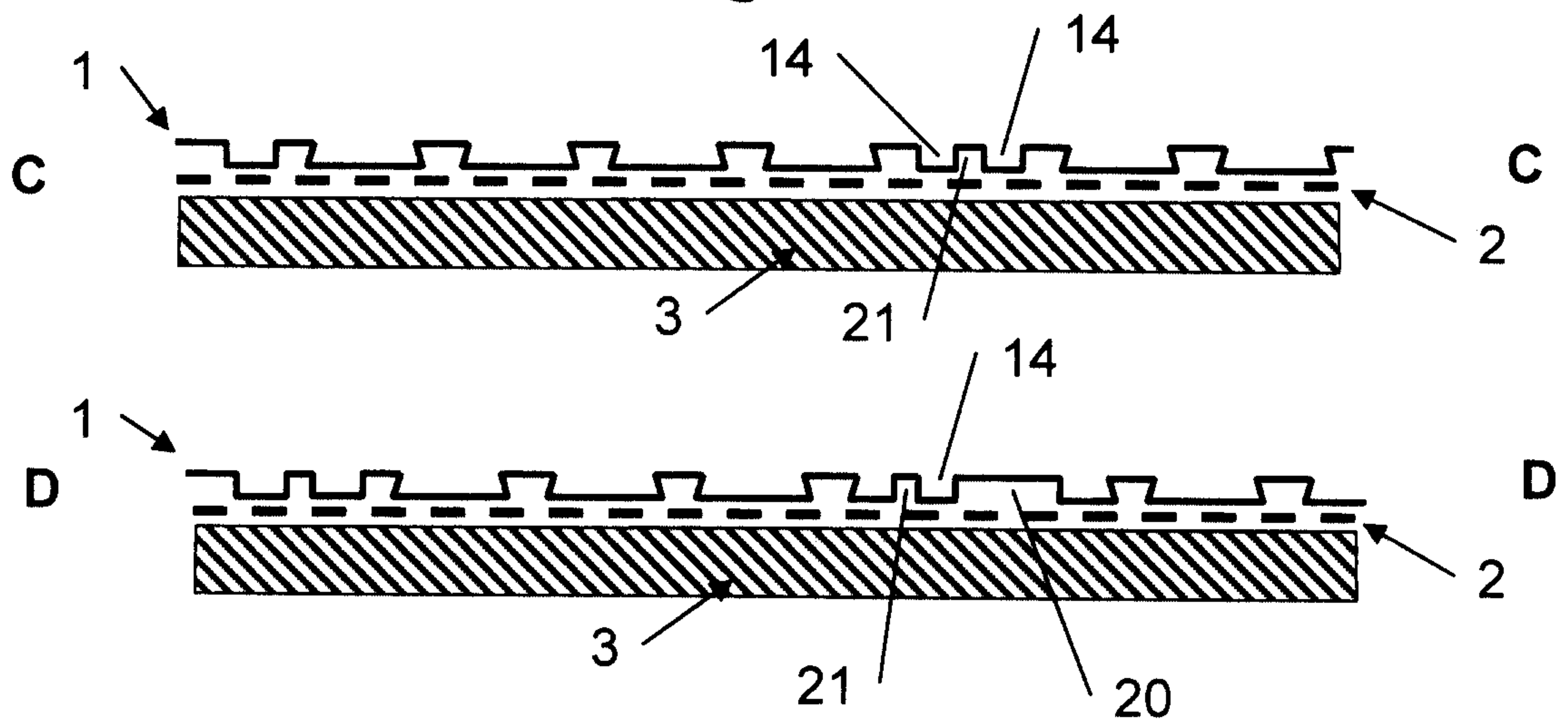

4/8

Fig 6

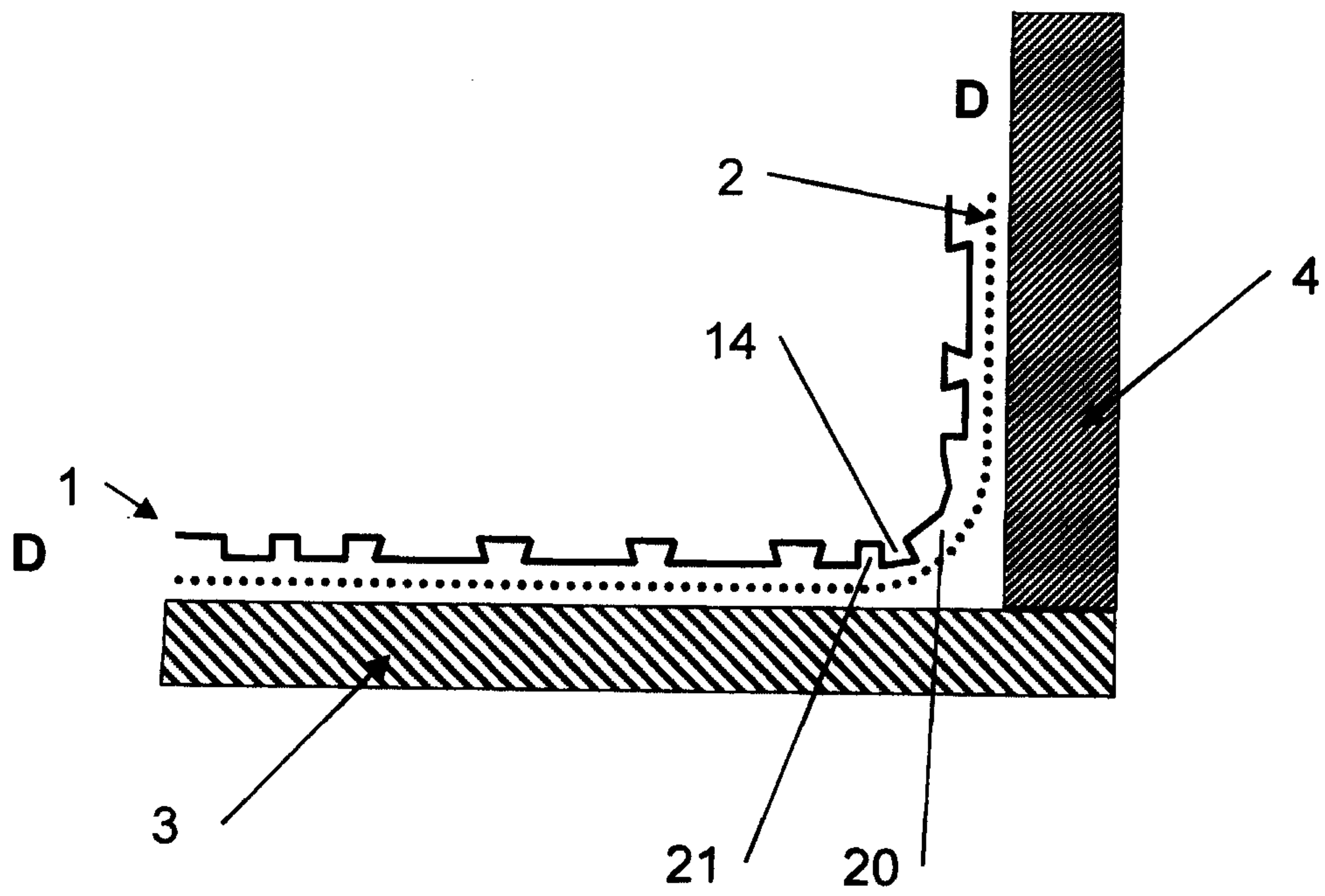
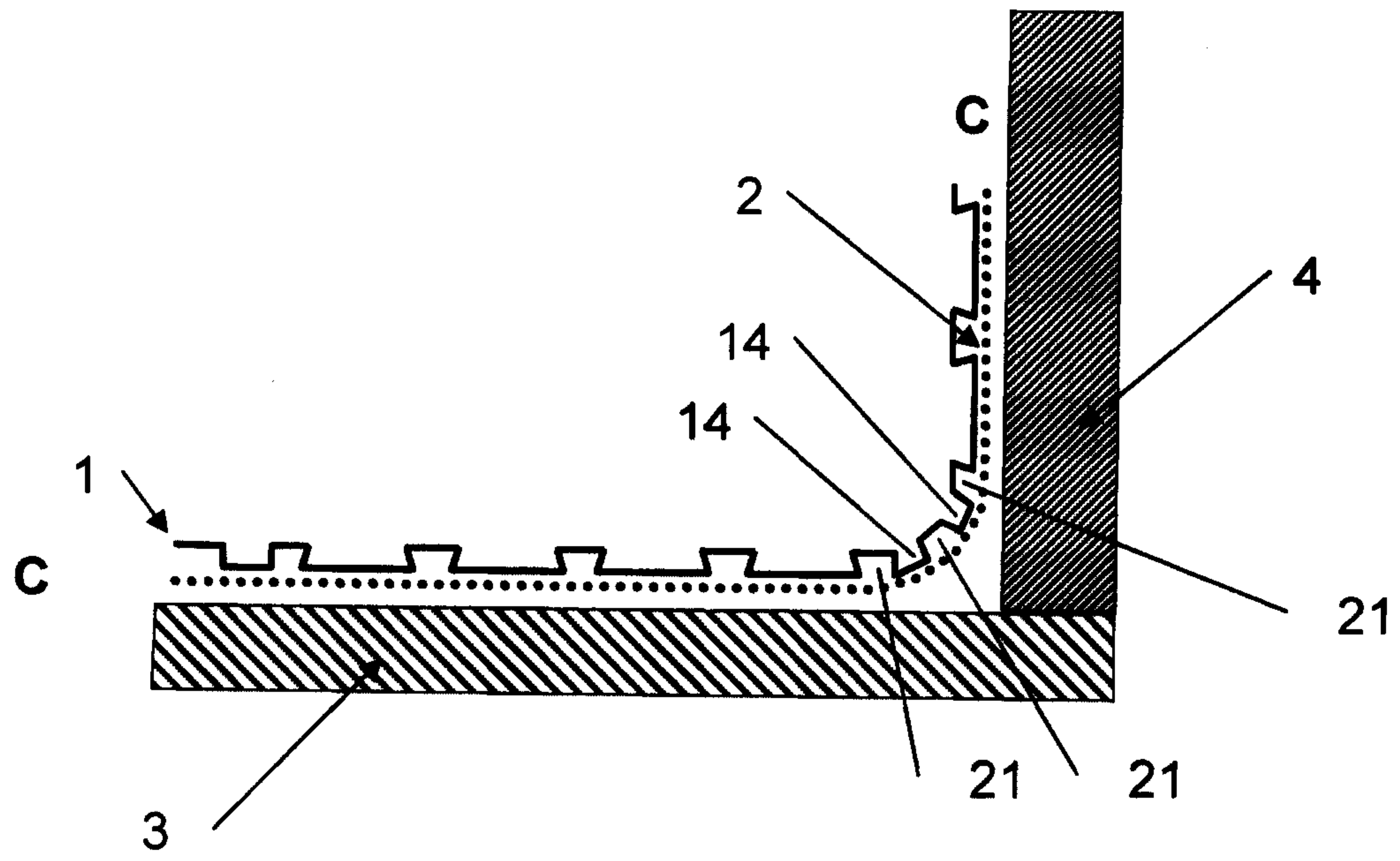
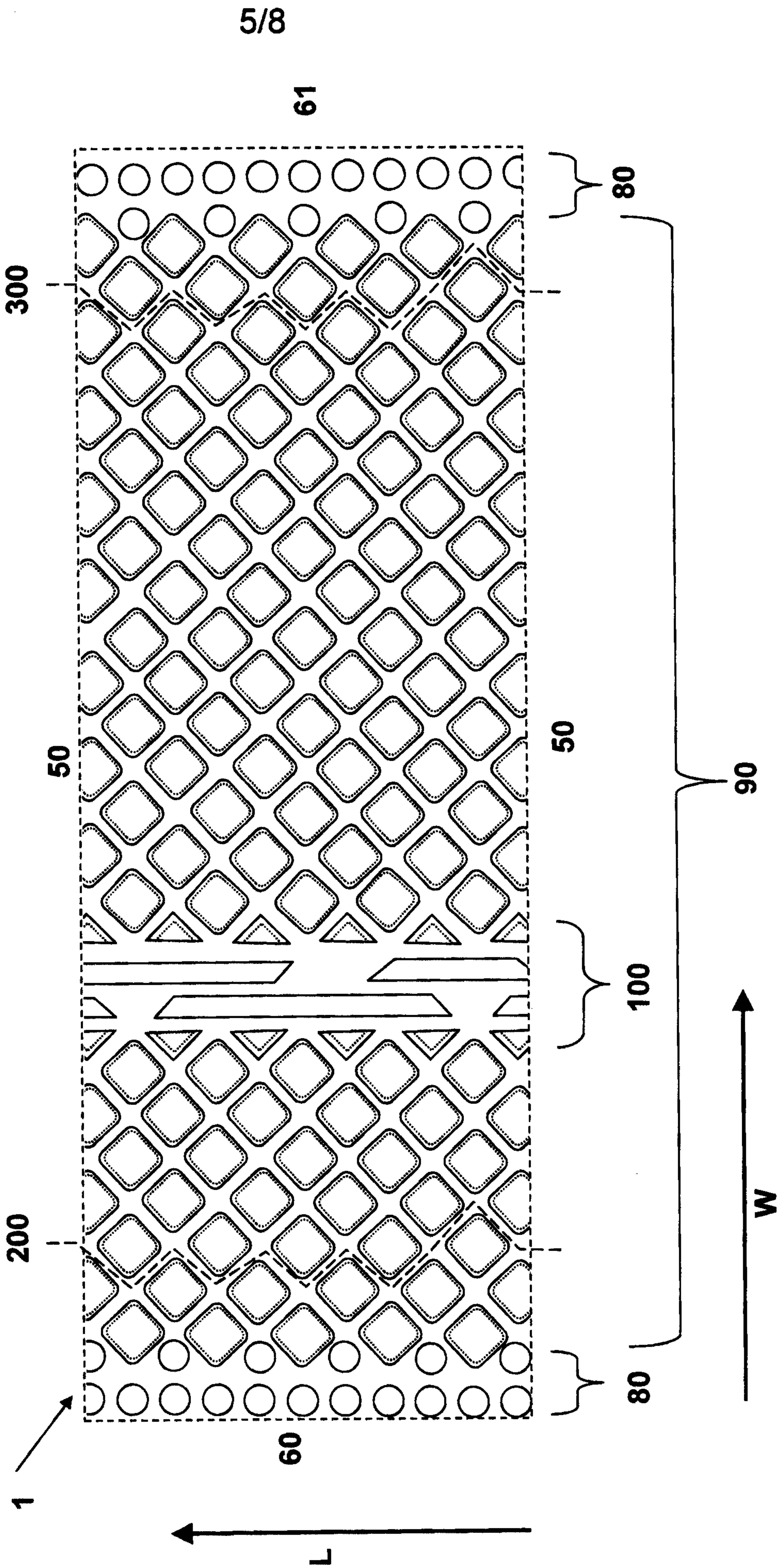
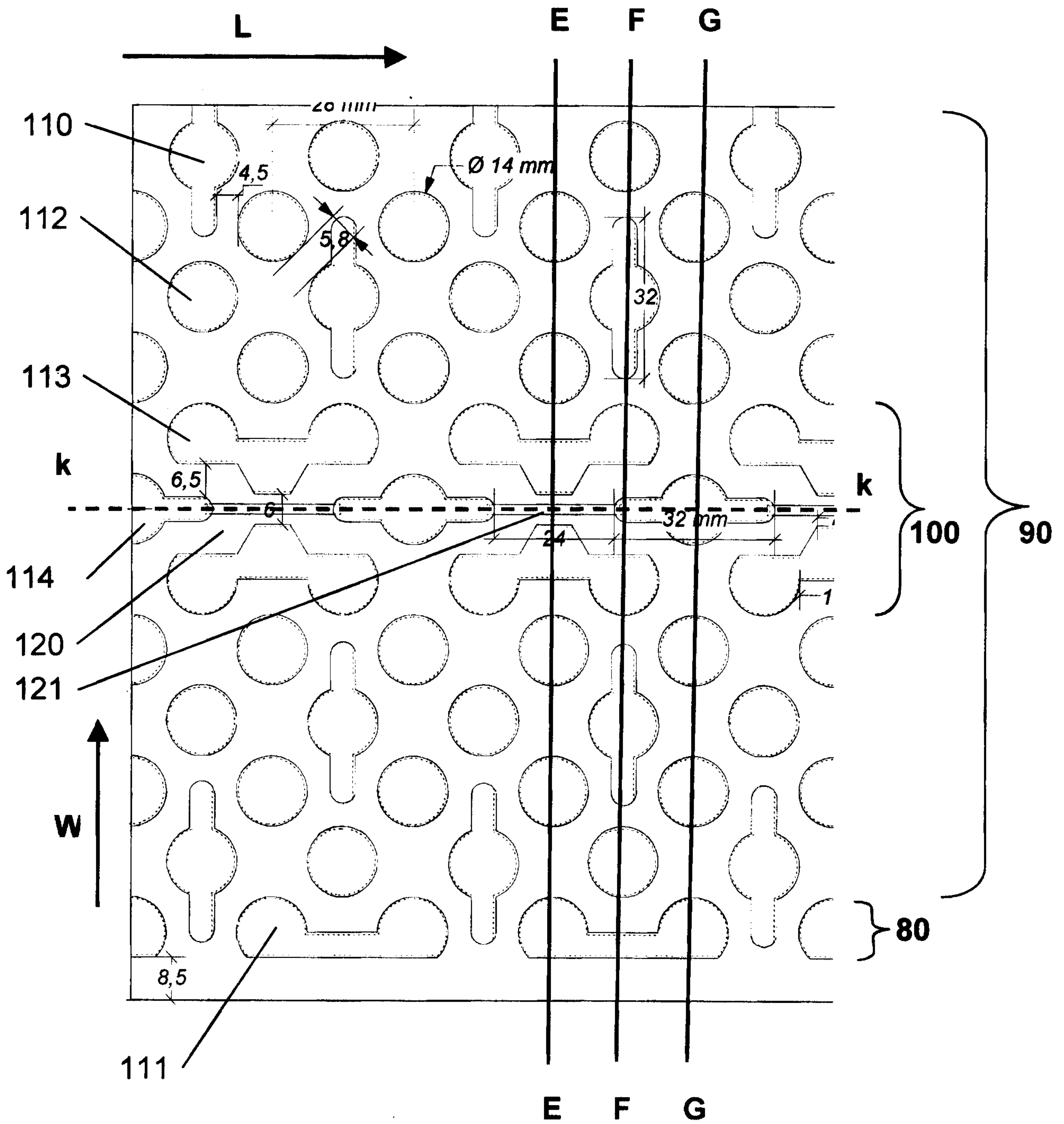

Fig 7



6/8

Fig 8



7/8

Fig 9

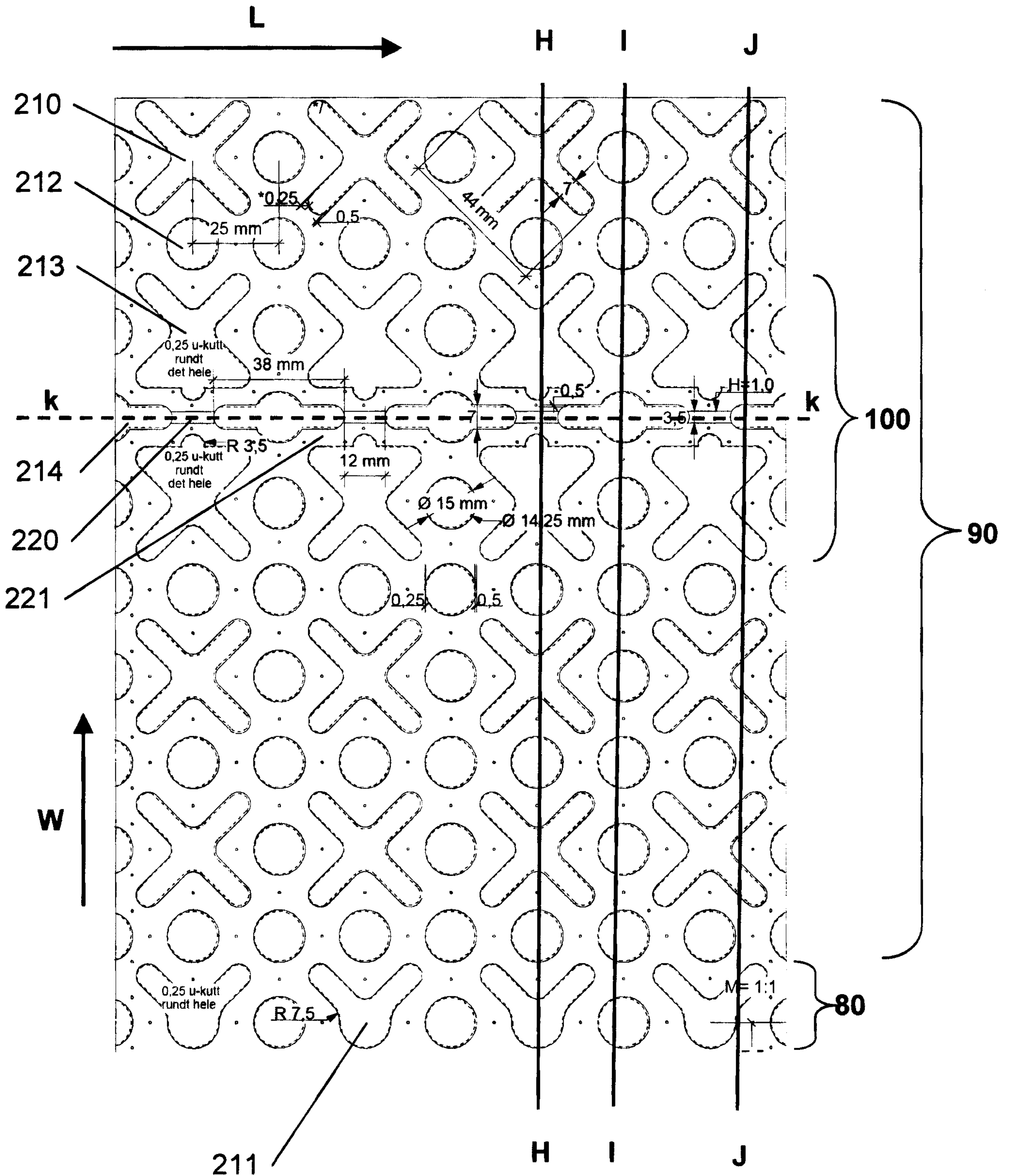

Fig 10

