



US 20060130786A1

(19) **United States**

(12) **Patent Application Publication**

**Schon et al.**

(10) **Pub. No.: US 2006/0130786 A1**

(43) **Pub. Date: Jun. 22, 2006**

(54) **DEVICE FOR ACTUATING THE GAS EXCHANGE VALVES IN RECIPROCATING ENGINES**

(57) **ABSTRACT**

(76) Inventors: **Helmut Schon**, Frastanz (AT);  
**Kai-Uwe Keller**, Kreuzlingen (CH)

Correspondence Address:  
**Max Fogiel**  
**44 Maple Court**  
**Highland Park, NJ 08904 (US)**

(21) Appl. No.: **10/542,170**

(22) PCT Filed: **Jan. 7, 2004**

(86) PCT No.: **PCT/EP04/00035**

(30) **Foreign Application Priority Data**

Jan. 22, 2003 (DE)..... 103 02 260.0

**Publication Classification**

(51) **Int. Cl.**  
**F01L 1/34** (2006.01)

(52) **U.S. Cl.** ..... **123/90.16**

A device is described for actuating the charge-cycling valves (V) in reciprocating internal combustion engines, consisting of a housing (G); a cam (N) mounted in the housing (G) in a revolutive joint (ng) so as to be able to rotate, the rotational movement of which cam is derived from a crankshaft; an intermediate member (Z) activated by this cam (N) by way of a first cam joint (zn); and a power take-off member (A) that transfers the movement to the valve (V), and is connected to act with the intermediate member (Z), directly or via other transfer elements, and at least one other cam joint (za) is provided within the active connection from the first cam joint (zn) to the power take-off member (A), whereby this other cam joint (za) is formed by a cam (Kz or Ka, respectively) on one of the two gear mechanism members (Z, A) that form the cam joint (za), in and of themselves, the shape of which cam has at least one point of inflection (W) in the contact region in which a valve lift is produced, whereby the point of inflection (W) is disposed in the region of the cam (Kz or Ka, respectively) that describes the greatest possible valve lift. In order to minimize the forces, i.e. moments between the gear mechanism members, and thus to keep the reactive forces in the system as low as possible, it is proposed that the point of inflection (W) be disposed in such a manner that the surface normal in the contact point, at which the greatest valve lift is achieved, is approximately equal to the surface normal in the contact point, at which the highest valve acceleration occurs.

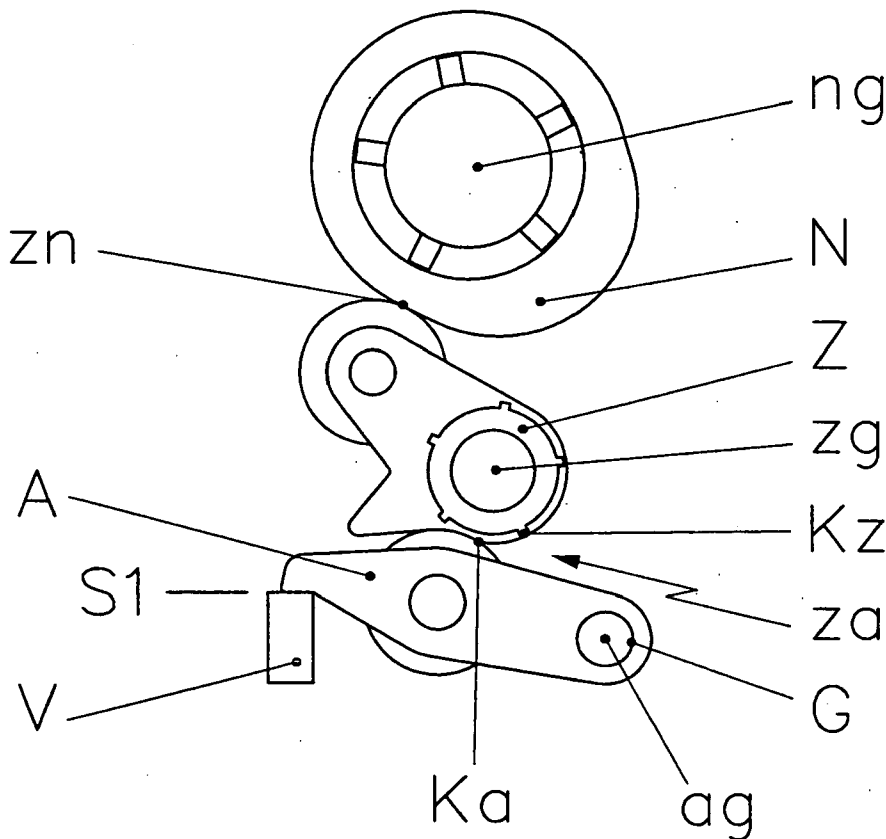

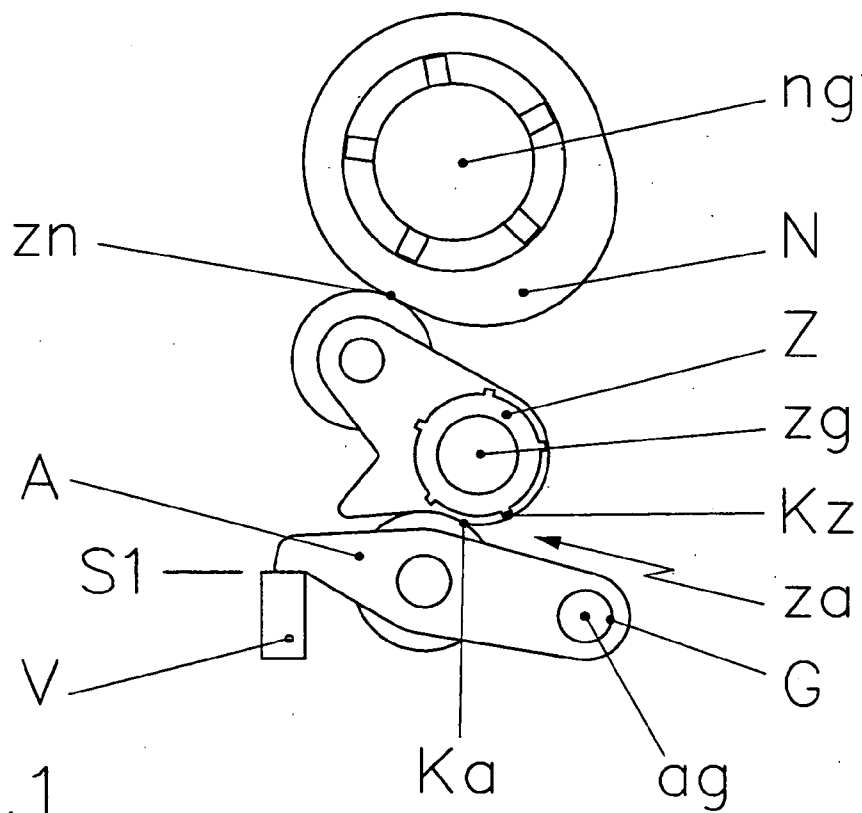

Fig.1

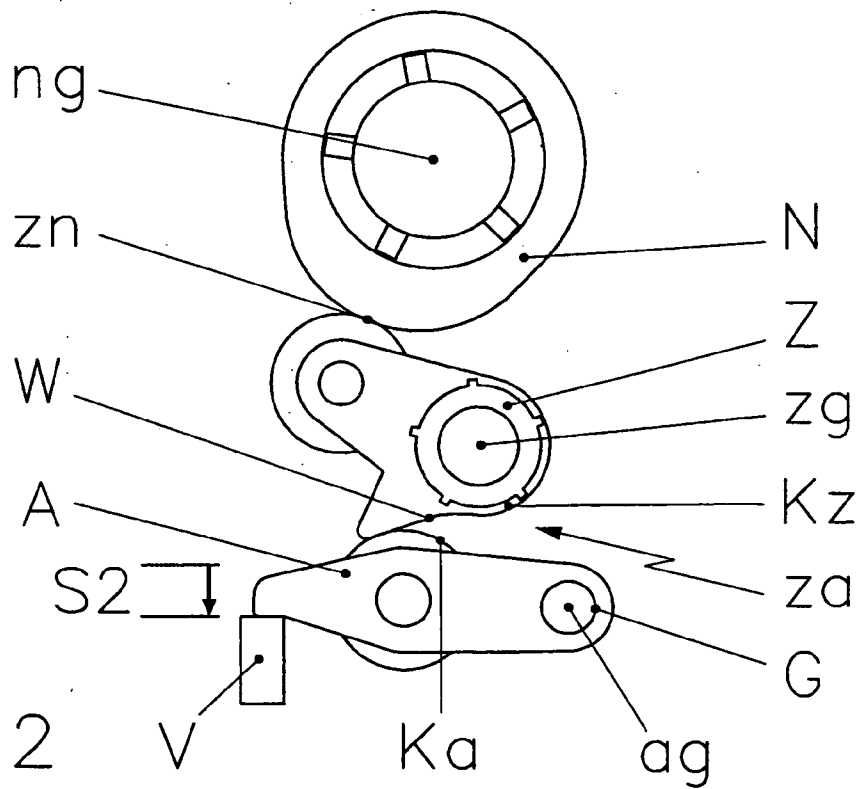

Fig.2

**DEVICE FOR ACTUATING THE GAS EXCHANGE VALVES IN RECIPROCATING ENGINES**

[0001] The invention relates to a device for actuating the charge-cycling valves in reciprocating internal combustion engines, consisting of a housing; a cam mounted in the housing in a revolute joint so as to be able to rotate, the rotational movement of which cam is derived from a crankshaft; an intermediate member activated by this cam by way of a first cam joint; and a power take-off member that transfers the movement to the valve, and is connected to act with the intermediate member, directly or via other transfer elements, and at least one other cam joint is provided within the active connection from the first cam joint to the power take-off member.

[0002] A fully variable mechanical valve drive for a piston internal combustion engine is described in DE-A 101 00 173, with drive means for generating a lifting movement that acts counter to the force of a closing spring in the charge-cycling valve, and with an intermediate element disposed between the drive means, such as a cam, and the charge-cycling valve. The element acts on the charge-cycling valve in the direction of its axis of movement, and the lift path of the element can be changed in the direction of the axis of movement, by way of an adjustable guide element.

[0003] A variable valve drive for controlling the load of a spark-ignited internal combustion engine is described in DE-A 100 06 018. The valve drive is formed from a cam of a camshaft and at least one inlet valve having a direct valve activation member, the power take-off member, a transfer member, and an adjustment means for influencing the lift function of the transfer member. The transfer member is installed as a drive between the cam and the power take-off member, and has a first contact surface impacted by the cam, as well as a second contact surface acting on the power take-off member.

[0004] In the state of the art, there is a plurality of mechanically variable valve drives for controlling or controlling the load of reciprocating internal combustion engines. The references cited above should therefore be viewed merely as examples. It is a common feature of the systems mentioned that a lift movement is transferred to the charge-cycling valve by means of the rotational movement of the cam of a camshaft. The resulting lifting curve of these charge-cycling valves can be changed during operation, by means of displacement of at least one of the gear mechanism members located in the force flow. In this connection, both the valve lift and the valve opening angle are changed. In order to make it possible for the displacement to be implemented, at least one gear mechanism member is inserted between the driving cam and the power take-off member that activates the charge-cycling valve. In this way, at least one additional degree of freedom in the movement is produced, so that the displacement desired, in each instance, becomes possible.

[0005] In this connection, there are valve drives, which consist of 4, 5, 6, or more gear mechanism members. The most cost-advantageous and simplest are the variable valve drives with four members. The complexity of the systems increases with an increasing number of gear mechanism members. The use of the inventive teaching therefore preferably takes place on systems having four or five members, although the teaching can also be used for systems having six or more members.

[0006] The transfer of force and moment between the members of the valve gear mechanism takes place by way of cam joints, sliding joints, and revolute joints. The moving gear mechanism members are supported in the housing directly or indirectly. The adjustment of the lift movement of the valve takes place, for example, by means of the displacement of joints or connecting link tracks in the housing, on which gear mechanism members that are part of the force flow are supported.

[0007] Important criteria of such valve gear mechanisms consist of the fact that with the change in the valve lift, the opening angle, i.e. the duration of the valve rest, is also changed, and that the contact between cam and intermediate member is constantly maintained.

[0008] Furthermore, the accelerations of the valve during valve opening should be as high as possible. The position and contours of the curve joints that are in engagement, as well as the position of the various revolute joints and sliding joints serve as influence factors for this purpose.

[0009] In the case of such valve drives, the forces are very dependent on the rpm. The spring forces of the valve gear mechanisms are designed in such a manner that the forces resulting from acceleration do not result in a loss of contact in the cam joints of the valve gear mechanism at the highest rpm for which the system is designed.

[0010] In the rest region of the valve, the forces introduced into the valve gear mechanism by the valve are zero. The control region of the valve can be divided into the region, in which the highest valve acceleration takes place and into the region, in which the greatest valve lift takes place. The region, in which the highest valve acceleration takes place, follows the rest region directly. In this region, the highest forces occur at high engine speeds of rotation, in a cam joint in which a gear mechanism member that moves back and forth participates.

[0011] Such systems are designed, for the transition from the rest region to the control region, in such a manner that the reactive forces that occur in this region are minimized.

[0012] The region in which the greatest valve lift occurs follows during the further progression of the valve lift. At high engine speeds of rotation, the forces decrease here. In the state of the art, however, the angle conditions in the gear mechanism change as a result of the valve stroke, in such a manner that even if the amounts of the forces that are introduced no longer increase, the reactive forces that result from them can still increase.

[0013] Furthermore, it is frequently a significant disadvantage, in the state of the art, that the adjustment forces, i.e. adjustment moments are very high, because of the cam shapes that are selected, so that disproportionately high forces must be introduced into the participating gear mechanism members.

[0014] As a consequence of the disadvantages of the state of the art described above, it may become necessary that at least individual gear mechanism members must be undesirably heavy so that they achieve a specified service life.

[0015] It is an object of the invention to develop the device described in the preamble of claim 1 or claim 10 further, in such a manner, that the forces or moments between the gear mechanism members, and if possible the forces or moments

within the setting device, are minimized. This means that the reactive forces in the system are kept as low as possible. At the same time, this results in an advantageous reduction in the friction forces.

[0016] This objective is accomplished with a device with the distinguishing features of claim 1 or claim 10.

[0017] The force direction can be determined freely, within certain limits, by means of the configuration of the contours participating in the cam joint. By inserting a point of inflection in one of the participating contours pursuant to the invention, the cam joint is configured in such a manner, that the angle of the force transmission remains as constant as possible during the entire movement sequence. As a result, the change in the amount of force introduced is kept as small as possible.

[0018] Studies have shown that the insertion of a point of inflection is necessary only at a contour point of the cam joint that is in contact at valve lifts, which are greater than 0.5 mm. The range of valve lifts of 2 mm to 7 mm is particularly preferred. In the preferred range, in the event that the greatest possible valve lift progression is selected, the valve acceleration has negative values, since the valve speed is being decelerated. The highest resulting reactive forces are to be expected specifically here.

[0019] In the following, the effect of the invention will be described using the example of the configuration of the cam joint between the intermediate member and power take-off member, with the inventive contour at the intermediate member. In the example, the power take-off member is formed by a drag lever or rocker lever.

[0020] The force introduced into the power take-off member is determined by the acceleration, friction, and spring forces from the valve, which is in operative connection with the power take-off member. These forces are specified by the special design of the engine. The values depend on the rpm of the engine and other influencing factors.

[0021] A force, corresponding to the normal at the instantaneous contact point of the cam joint between power take-off member and intermediate member, is introduced into the intermediate member by the power take-off member. The magnitude of the force, introduced into the intermediate member, is determined by the ratio of the distances between the point of rotation of the power take-off member in the housing and the lines of action of the forces, on the one hand, to the intermediate member and, on the other, to the valve. The line of action of the force, in each case, is the straight line, which is determined by the direction and the location of the force. The directions of the forces therefore essentially determine the force introduced into the intermediate member. The lowest force is introduced into the intermediate member if the direction of the force, introduced into the intermediate member, is perpendicular to the line connecting the point of rotation of the power take-off member with the contact point of the force,

[0022] With the inventive object, the change in direction of the force is determined by describing direction of the surface normal in the contact point in this cam joint. To avoid the above-mentioned reactive forces, it is advantageous to implement the surface normal in the contact point, at which the greatest valve lift is achieved, to be approximately equal to the surface normal in the contact point, at

which the highest valve acceleration occurs. Such a change in direction can be implemented, pursuant to the invention, by means of a point of inflection in one of the two cams of the cam joint in question.

[0023] To adhere to the specified valve lift curve, the contour at the cam, for example, is adapted correspondingly.

[0024] The mechanism of effect described above also applies when cup tappet is used as the power take-off member and it must be applied analogously.

[0025] Furthermore, the inventive teaching can also be applied to valve gear mechanisms, in which the cam joint, configured pursuant to the invention, is disposed at a location different from that described above. In this connection, it is immaterial whether the cam of a cam joint of the gear members, which engage one another, is configured in this manner, or a cam in the housing, on which one of the gear mechanism members is supported in a cam joint.

[0026] Advantageous further developments of the object of the invention are evident from the dependent claims.

[0027] By means of the inventive object, a solution is now made available by means of which the forces or moments between the gear mechanism members, and if possible the forces or moments within the adjustment device, are minimized. This means that the reactive forces in the system are kept as low as possible, which at the same time advantageously results in a reduction in the friction forces.

[0028] The inventive object can be implemented, in general, in all cam joints in the valve gear mechanism, with the exception of the cam joint, in which the driving, rotating cam participates. The inventive implementation of the cam of the cam joint at one of the participating gear mechanism members acts on both of the gear mechanism members that form this cam joint. It is therefore immaterial on which of the two participating cams of the cam joint the inventive embodiment is disposed. In the preferred embodiment of the valve gear mechanism, the contour described in the object of the invention is used on one of the cams of the intermediate member. Preferably, in this connection, the cam joints of the intermediate member to the power take-off member or to the housing can be selected.

[0029] In an advantageous further development of the invention, in addition to the formation of a point of inflection in the region of the valve lift, the transition region from the rest region to the control region is specifically represented. In this connection, this transition region plays a significant role both for the opening and for the closing of the valve. While the opening process is supposed to take place as quickly as possible, the end phase of the closing speed must be limited in order to limit wear and the development of noise. Since the same transition region between the rest region and the control region is passed through, the two opposing requirements must be resolved with a compromise. The direct transition region between the rest region and the control region is formed from segment sections and evolvent sections.

[0030] The inventive object is shown in **FIGS. 1 and 2** by means of an example and is described as follows. In the drawing,

[0031] **FIGS. 1 and 2** show different positions of a valve gear mechanism for variable actuation of the charge-cycling valves in reciprocating internal combustion engines.

[0032] **FIGS. 1 and 2** show a device for actuating a charge-cycling valve V in a reciprocating internal combustion engine, the details of which are not shown. The device contains a housing G, a cam N mounted in the housing G in a revolute joint ng so as to be able to rotate, the rotational movement of which cam is derived from a crankshaft, not shown in further detail. An intermediate member Z is activated by this cam N, by way of a first cam joint zn, which member acts on a power take-off member A that transfers the movement to the valve V. A further cam joint za is provided in an active connection from the first cam joint zn to the power take-off member Z, which joint is formed by the contours Kz on the intermediate member and Ka on the power take-off member. The shape of the contour Kz on the intermediate member usually has a point of inflection W2 precisely at the transition between the region in which no valve lift takes place (the region of the valve being held closed) and the region in which valve lift takes place (the control region that exists during opening of the valve). Furthermore, the shape of the contour Kz on the intermediate member has a point of inflection W in the contact region in which a valve lift that is greater than zero is produced. The point of inflection W is located essentially in the region of the cam joint that is to be assigned to the region of the starting and the ending valve lift. As is particularly evident from **FIG. 2**, the point of inflection W is disposed in the region of the cam Kz that describes the greatest possible valve lift. The cam Ka is formed by an arc, in this example, but other geometric shapes are also possible. The cam joint za is disposed between the intermediate member Z and the power take-off member A, in this example.

[0033] **FIG. 1** essentially describes the region of the valve being closed, i.e. valve lift  $s_1=0$ , while **FIG. 2** describes that control region that exists while the valve V is open, i.e. valve lift  $s_2>0$ .

[0034] In the examples, only a single intermediate member Z is provided. As described in the state of the art, of course, additional transfer members can also be provided, so that these are also covered by the scope of protection.

1. Device for actuating the charge-cycling valves (V) in reciprocating internal combustion engines, consisting of a housing (G); a cam (N) mounted in the housing (G) in a revolute joint (ng) so as to be able to rotate, the rotational movement of which cam is derived from a crankshaft; an intermediate member (Z) activated by this cam (N) by way of a first cam joint (zn); and a power take-off member (A) that transfers the movement to the valve (V), and is connected to act with the intermediate member (Z), directly or via other transfer elements, and at least one other cam joint (za) is provided within the active connection from the first cam joint (zn) to the power take-off member (A), characterized in that this other cam joint (za) is formed by a cam (Kz or Ka, respectively) on one of the two gear mechanism members (Z, A) that form the cam joint (za), in and of themselves, the shape of which cam has at least one point of inflection (W) in the contact region in which the valve has a valve lift that is greater than zero.

2. Device of claim 1, characterized in that the movement transferring to the valve (V) can be changed by means of modifying the position and the orientation of at least one gear mechanism member or its joint positions to the housing (G).

3. Device of claim 1, characterized in that the cam joint (za) at one of the two gear mechanism members (Z, A) forming the same is formed by a cam (Kz or Ka, respectively), the shape of which has a point of inflection (W) precisely in the contact region in which the valve has a valve lift that is greater than zero.

4. Device of one of claims 1, characterized in that the point of inflection (W) is disposed essentially in the region of the starting and ending valve lift.

5. Device of one of claims 1, characterized in that the point of inflection (W) is disposed in the region of the cam (Kz or Ka, respectively) that describes the greatest possible valve lift.

6. Device of one of claims 1, characterized in that the cam joint (za) is formed on the other of the two gear mechanism members (Z, A) forming the same, by a cam (Ka or Kz, respectively), the shape of which is formed by an arc or a circle.

7. Device of one of claims 1, characterized in that the cam joint (za) is disposed between the intermediate member (Z) and the power take-off member (A).

8. Device of one of claims 1, characterized in that the cam joint (za) is disposed between the intermediate member (Z) and the housing (G).

9. Device of one of claims 1, characterized in that the cam joint (za) is disposed on a transfer member located between the intermediate member (Z) and the power take-off member (A).

10. Device for actuating the charge-cycling valves (V) in reciprocating internal combustion engines, consisting of a housing (G); a cam (N) mounted in the housing (G) in a revolute joint (ng) so as to be able to rotate, the rotational movement of which cam is derived from a crankshaft; an intermediate member (Z) activated by this cam (N) by way of a first cam joint (zn); and a power take-off member (A) that transfers the movement to the valve (V), and is connected to act with the intermediate member (Z), directly or via other transfer elements, and at least one further cam joint (za) is provided within the active connection from the first cam joint (zn) to the power take-off member (A), characterized in that this further cam joint (za) at one of the two gear mechanism members (Z, A), which form the cam joint (za), in and of themselves, is formed by a cam (Kz or Ka), the shape of which, in the contact region, in which the transition from the region, in which no valve lift is produced, into the region, in which a valve lift is produced, is formed by a segment and an evolvent section.

11. Device for actuating the charge-cycling valves (V) in reciprocating internal combustion engines, consisting of a housing (G); a cam (N) mounted in the housing (G) in a revolute joint (ng) so as to be able to rotate, the rotational movement of which cam is derived from a crankshaft; an intermediate member (Z) activated by this cam (N) by way of a first cam joint (zn); and a power take-off member (A) that transfers the movement to the valve (V), and is connected to act with the intermediate member (Z), directly or via other transfer elements, and at least one other cam joint (za) is provided within the active connection from the first cam joint (zn) to the power take-off member (A), whereby this other cam joint (za) is formed by a cam (Kz or Ka, respectively) on one of the two gear mechanism members (Z, A) that form the cam joint (za), in and of themselves, the shape of which cam has at least one point of inflection (W) in the contact region in which a valve lift is produced,

whereby the point of inflection (W) is disposed in the region of the cam (Kz or Ka, respectively) that describes the greatest possible valve lift, characterized in that the point of inflection (W) is disposed in such a manner that the surface normal in the contact point at which the greatest valve lift is achieved is approximately equal to the surface normal in the contact point at which the highest valve acceleration occurs.

**12.** Device of claim 1, characterized in that the movement transferring to the valve (V) can be changed by means of modifying the position and the orientation of at least one gear mechanism member or its joint positions to the housing (G).

**13.** Device of claim 1 or 2, characterized in that the cam joint (za) at one of the two gear mechanism members (Z, A) forming the same is formed by a cam (Kz or Ka, respectively), the shape of which has a point of inflection (W) precisely in the contact region in which the valve has a valve lift that is greater than zero.

**14.** Device of one of claims 1 to 3, characterized in that the cam joint (za) is formed on the other of the two gear mechanism members (Z, A) forming the same, by a cam (Ka or Kz, respectively), the shape of which is formed by an arc or a circle.

**15.** Device of one of claims 1 to 4, characterized in that the cam joint (za) is disposed between the intermediate member (Z) and the power take-off member (A).

**16.** Device of one of claims 1 to 4, characterized in that the cam joint (za) is disposed between the intermediate member (Z) and the housing (G).

**17.** Device of one of claims 1 to 4, characterized in that the cam joint (za) is disposed on a transfer member located between the intermediate member (Z) and the power take-off member (A).

\* \* \* \* \*