



- (51) **International Patent Classification:**
A24B 3/12 (2006.01) *A24B 15/30* (2006.01)
- (21) **International Application Number:**
PCT/EP2012/053799
- (22) **International Filing Date:**
6 March 2012 (06.03.2012)
- (25) **Filing Language:** English
- (26) **Publication Language:** English
- (30) **Priority Data:**
1104311.4 15 March 2011 (15.03.2011) GB
- (71) **Applicant (for all designated States except US):** **BRITISH AMERICAN TOBACCO (INVESTMENTS) LIMITED** [GB/GB]; Globe House, 1 Water Street, London WC2R 3LA (GB).
- (72) **Inventor; and**
- (75) **Inventor/Applicant (for US only):** **MCLELLAN, Andy** [GB/GB]; British American Tobacco (Investments) Limited, Globe House, 1 Water Street, London WC2R 3LA (GB).
- (74) **Agents:** **READ, Matthew** et al.; Venner Shipley LLP, 200 Aldersgate, London EC1A 4HD (GB).

- (81) **Designated States (unless otherwise indicated, for every kind of national protection available):** AE, AG, AL, AM, AO, AT, AU, AZ, BA, BB, BG, BH, BR, BW, BY, BZ, CA, CH, CL, CN, CO, CR, CU, CZ, DE, DK, DM, DO, DZ, EC, EE, EG, ES, FI, GB, GD, GE, GH, GM, GT, HN, HR, HU, ID, IL, IN, IS, JP, KE, KG, KM, KN, KP, KR, KZ, LA, LC, LK, LR, LS, LT, LU, LY, MA, MD, ME, MG, MK, MN, MW, MX, MY, MZ, NA, NG, NI, NO, NZ, OM, PE, PG, PH, PL, PT, QA, RO, RS, RU, RW, SC, SD, SE, SG, SK, SL, SM, ST, SV, SY, TH, TJ, TM, TN, TR, TT, TZ, UA, UG, US, UZ, VC, VN, ZA, ZM, ZW.
- (84) **Designated States (unless otherwise indicated, for every kind of regional protection available):** ARIPO (BW, GH, GM, KE, LR, LS, MW, MZ, NA, RW, SD, SL, SZ, TZ, UG, ZM, ZW), Eurasian (AM, AZ, BY, KG, KZ, MD, RU, TJ, TM), European (AL, AT, BE, BG, CH, CY, CZ, DE, DK, EE, ES, FI, FR, GB, GR, HR, HU, IE, IS, IT, LT, LU, LV, MC, MK, MT, NL, NO, PL, PT, RO, RS, SE, SI, SK, SM, TR), OAPI (BF, BJ, CF, CG, CI, CM, GA, GN, GQ, GW, ML, MR, NE, SN, TD, TG).

Published:

- without international search report and to be republished upon receipt of that report (Rule 48.2(g))



WO 2012/123285 A2

(54) **Title:** METHOD AND APPARATUS FOR IMPREGNATING TOBACCO INDUSTRY PRODUCTS WITH SENSATE CONSTITUENTS OF BOTANICALS

(57) **Abstract:** A method and apparatus for impregnating tobacco industry products with sensate constituents of botanicals by storing the tobacco industry products and the botanicals separately and applying heat and/or pressure to the apparatus to obtain a modified taste and aroma profile, are disclosed.

Method and apparatus for impregnating tobacco industry products with sensate constituents of botanicals

The invention relates to the field of tobacco industry products.

5

It is known in the art, where permitted by local regulations, to provide tobacco products, such as cigarettes, cigars, snus, chewing tobacco and the like that include additives in order to provide a modified taste and aroma profile compared with tobacco products that lack additives. Examples of suitable additives include menthol, coffee, juniper, elderflower, star
10 anise as well as many others.

Hitherto, such flavour additives have been applied to tobacco industry products in ways such as mixing the additives with tobacco prior to the formation of tobacco rods during the manufacture of smoking articles. Alternatively, additives may be applied to a wrapper
15 circumscribing a tobacco rod. In this case the additive may be provided in the form of an adhesive. In both of these approaches a certain amount of contact between tobacco product and additive is required.

According to one aspect of the present invention there is provided a method and apparatus
20 for impregnating a tobacco industry product with a sensate constituent of a botanical, the apparatus comprising a first portion for receiving the tobacco industry product and a second portion for receiving the botanical, wherein the tobacco industry product becomes impregnated by the sensate constituent of the botanical when the first portion is pressurised and the sensate constituent is released into the first portion.

25

According to another aspect of the present invention there is provided an apparatus and method for impregnating a tobacco industry product with a sensate constituent of a botanical, the apparatus comprising a botanical storage chamber, a vapour source and a tobacco storage chamber, wherein the vapour source is disposed relative to the botanical
30 storage chamber so that, in use, vapour passes through botanicals stored in the botanical storage chamber and impregnates tobacco stored in the tobacco storage chamber with sensate constituents of the botanical.

So that the present invention may be more fully understood embodiments thereof will now
35 be described with reference to the accompanying drawings in which:

Figure 1 is a three dimensional view of a pressure vessel according to one embodiment of the present invention;

Figure 2 is a three dimensional view of a container for use in conjunction with the pressure vessel of Figure 1;

Figure 3 is a part exploded three dimensional view of a pressure vessel according to another embodiment of the present invention;

Figure 4 is a side view of apparatus according to another embodiment of the present invention; and

Figure 5 is a side view of a storage vessel used with the apparatus of Figure 4 according to another embodiment of the present invention.

15

Figure 1 shows a cylindrical vessel 1 suitable for storing tobacco industry product 5 and botanicals 10 at high pressure. In Figure 1 the tobacco industry product 5 is cut or shredded tobacco however other tobacco industry products could equally be employed. The term tobacco industry product should be understood to include products used in the tobacco industry, such as snus, smoking article filters, filtration material, entire smoking articles, fully or partially assembled smoking article containers, blanks for forming smoking article containers and so forth. Using blanks rather than fully formed smoking article containers has the advantage of conserving space.

In this embodiment of the invention the botanicals 10 are stored in cylindrical containers 15 which may be stacked on top of each other and placed inside, and along the central axis of, the cylindrical vessel 1. When the containers 15 are placed inside the vessel 1 that part of the vessel 1 surrounding the central stack of containers 15 forms an annular chamber 20 in which the tobacco industry product 5 may be stored.

Figure 2 shows the containers 15 in more detail. The containers 15 may have side walls 16 formed from wire mesh stainless steel or aluminium although other materials that can provide gaps in the surface may also be used as will be obvious to the person skilled in the art. For example, perforated metal might be employed to form the side walls 16. The containers 15 shown in Figure 2 have a solid base 17 although containers 15 with a mesh or perforated metal base may also be used.

The containers 15 shown in Figure 2 have side walls with a mesh size of between 200 and 250 microns although different mesh sizes may be used depending on factors such as the type of tobacco industry product 5 or botanical 10 in order to allow the release, from the
5 containers 15 into the annular chamber 20, of those constituents within the botanical 10 responsible for imparting taste and aroma characteristics.

The botanical 10, being in a central position within the vessel 1, may impart flavour to the surrounding tobacco industry product 5 within the annular chamber 20. The botanical 10
10 may be formed from botanicals such as menthol, juniper, coffee, anise or any other botanical whose characteristics can be exploited in the production and treatment of tobacco industry products. By storing the botanical 10 in the containers 15 the botanical 10 may be kept separate from the tobacco industry product 5.

15 An advantage of the arrangement of the containers 15 in the cylindrical vessel 1 shown in Figure 1 is that it allows effective circulation within the annular chamber 20 of those constituents contained in the botanical 10 that are responsible for imparting flavour and aroma.

20 In alternative embodiments of the present invention, where the vessel 1 is of a different shape to that shown in Figure 1, the stack of containers 15 may be placed in a non-central position within the vessel 1. Alternatively, more than one stack of containers 15 may be employed. In any case, the position of the containers 15 containing the botanical 10 may be varied to ensure an effective circulation of flavour and aroma imparting constituents in
25 the vessel 1.

After loading the annular chamber 20 of the vessel 1 with tobacco industry product 5 and the central stack of mesh containers 15 with botanical 10, a lid 21 of the vessel 1 is closed. The vessel 1 may then be pressurised via an air inlet 22. The pressure inside the vessel 1
30 may be monitored using a pressure gauge 25. A safety valve 30 may be used to release air from the vessel 1 in the event that the internal air pressure exceeds a predetermined, safe value. In use, the vessel 1 has been pressurised to between 18 and 25 pounds per square inch, hereinafter denoted as psi, resulting in tobacco industry product 5 with a modified taste and aroma profile.

35 A heat mat 35 may be placed beneath the vessel 1 to heat the contents thereof. The increase in temperature obtained by applying heat to the vessel 1 leads to an increase in the

pressure inside the vessel 1 assuming that the amount of air held inside the vessel 1 is kept substantially constant. Alternative heat sources that may be employed to supply heat to the vessel 1 will be apparent to those skilled in the art. In use, the vessel 1 has been heated to temperatures of approximately 45 degrees Celsius (°C). In the case where the vessel 1 is heated the tobacco industry product 5 may be treated with water prior to loading into the annular chamber 20 so that the tobacco industry product 5 does not dry out excessively.

After the contents of the vessel 1 have been stored under high pressure for a predetermined period of time the pressure may be released and the tobacco industry product 5 removed.

In embodiments of the present invention where the tobacco industry product 5 is tobacco, tobacco rods may be formed for use in smoking articles in a manner well known in the art. The tobacco thus treated provides a different taste and aroma profile compared with tobacco that has not undergone this process.

In addition to the arrangement shown in Figures 1 and 2, it is also possible to store the tobacco industry product 5 in a tobacco storage vessel 40 and store the botanical 10 in a botanical storage vessel 50 separate from, and connected to, the chamber 40, as shown in Figure 3. Sensate constituents of the botanical 10 may then be released into the chamber 40 and alter the flavour and aroma characteristics of the tobacco industry product 5.

The tobacco storage vessel 40 shown in Figure 3 comprises an chamber 41 wherein the tobacco industry product 5 may be stored. A mesh shelf 42 may be located inside the vessel 40 to support the tobacco industry product 5 thereon. The storage vessel 40 may comprise a lid 21 and pressure gauge 25 and a safety valve such as the safety valve shown in Figure 1 may also be provided.

In the embodiment shown in Figure 3 the botanical 10 is stored in the botanical storage vessel 50. The botanical 10 can be stored in the botanical storage vessel 50 as a solid, for example in leaf or berry form. Alternatively, the botanical 10 may be stored in the form of a gaseous extract or as a pressurised liquid which may be accompanied by a suitable propellant. In the latter case where the botanical 10 is in gaseous or pressurised liquid form the botanical storage vessel 50 may be modified to accommodate gaseous or liquid contents in a way that would be apparent to those skilled in the art.

Air may be pumped between the tobacco storage vessel 40 and the botanical storage vessel 50 through tubing 51 using a pump 52. The tubing 51 may be considered to comprise three portions and may be constructed from any material suitable for conveying air that will be apparent to those skilled in the art. The first portion 51a extends between the
5 pump 52 and the botanical storage vessel 50. The second portion 51b extends between the botanical storage vessel 50 and the tobacco storage vessel 40. The third portion extends from the tobacco storage vessel 40 to the pump 52. Air may be pumped by the pump 52 in the direction shown by the arrows in Figure 3.

10 In use, air is pumped through the first portion 51a of the tubing 51 into the botanical storage chamber 50. Sensate components of the botanical 10 are conveyed in the air stream through the second portion of tubing 51b into the tobacco storage vessel 40. Inside the tobacco storage vessel 40 the air conveying sensate constituents of the botanical
15 10 travels through the tobacco industry product 5 stored in the chamber 41. In this part of the process the tobacco industry product 5 becomes impregnated with sensate constituents of the botanical 10. Air can exit the tobacco storage vessel 40 through the third portion of tubing 51c. Air may then be recirculated by the tubing 51 for a given amount of time.

Figure 4 shows an alternative arrangement comprising a botanical storage vessel 60, a
20 tobacco mixing drum 70 and a peristaltic pump 80. Air is pumped through an air pipe 90a into the botanical storage vessel 60 by the peristaltic pump 80. A pipe 90b extends between the storage vessel 60 and the mixing drum 70 and a further pipe 90c extends between the mixing drum 70 and the peristaltic pump 80. The apparatus shown in Figure 4 is operated at atmospheric pressure.

25 The storage vessel 60 has an internal chamber 100 to hold botanical products 10 such as juniper, coffee, star anise or any other suitable botanical product. The botanical product 10 is supported on a wire mesh 110 located in the lower portion 115 of the chamber 100. Water is stored in the portion of the chamber 100 below the wire mesh 110. The sides of
30 the vessel 60 are wrapped by a heat jacket 120 and a heat mat 130 is placed under the vessel 60. The heat jacket 120 and heat mat 130 are configured to apply heat to the contents of the chamber 100. The pipe 90a which connects the peristaltic pump 80 to the storage vessel 60 enters the vessel 60 from above. Air pumped into the vessel 60 then passes through an internal pipe 140 located inside the vessel 60.

35

The tobacco mixing drum 70 is arranged to hold a quantity of tobacco industry product 5 to be infused or impregnated with sensate constituents from the botanical products 10 stored in the storage vessel 60. The mixing drum 70 may be configured such that it can be rotated about its central axis 145. Rotating the mixing drum 70 facilitates the infusion of
5 the tobacco industry product 5 with sensate constituents of the botanical products 10.

In use, air is pumped by the peristaltic pump 80 into the storage vessel 60. The air is fed to the lower portion of the internal chamber 100 through the internal pipe 140 and passes through the water stored in the part of the chamber 100 below the wire mesh 110 which
10 supports the botanical product 10. Preferably, the heat jacket 120 and heat mat 130 heat the storage vessel to approximately 90°C. The applied heat and the air flow act to evaporate a substantial proportion of the water stored in the storage vessel 60 creating water vapour. The air and water vapour are forced upwards through the wire mesh 110 and through the botanical product 10. The air is then forced out of the vessel 60 through
15 the pipe 90b that connects the vessel 60 with the mixing drum 70 which contains a quantity of tobacco industry product 5 to be infused with the botanical product 10.

The mixing drum 70 is at a lower temperature than the storage chamber 60 therefore water vapour conveyed into the drum 70 from the storage chamber 60 through the pipe 90b
20 condenses in the drum 70.

The drum 70 may be rotated about a cylindrical axis 145. This allows a thorough circulation of the tobacco industry product 5 and condensed water within the drum 70. In this way the tobacco industry product 5 becomes infused with sensate constituents from
25 the botanical product 10. The process described above is continued until all the water stored in the storage chamber 60 has been evaporated.

An alternative storage vessel 60 is shown in Figure 5. The vessel 60 is elongate with air from the peristaltic pump 80 entering the vessel from an inlet 150 located in the lower
30 portion of the vessel 60. Water is stored in a water storage chamber 150 and fed into the vessel 60 through a water inlet controlled by a valve 180. As in the vessel 60 shown in Figure 4 the vessel 60 shown in Figure 5 is heated by a heat jacket 120. Water is evaporated by the air flow and applied heat. Water vapour is conveyed upwards through the botanical product 10 stored in the chamber 100 and supported on the wire mesh 110.
35 The air containing water vapour leaves the vessel 60 via an air outlet 190 and is conveyed

towards a mixing drum 70 as shown in Figure 4, where the condensation of the water vapour and infusion of the tobacco industry product 5 stored therein take place.

In addition to the embodiments hereinbefore described various modifications may be made to the apparatus and method of impregnating tobacco industry products with botanicals without departing from the scope of the invention which is defined by the following claims.

Experimental Data

10

Experiments were performed to analyse the effects of different infusion conditions when infusing tobacco with juniper using the apparatus described above with reference to Figures 4 and 5. Five samples were investigated using Solid Phase Microextraction - Gas Chromatography/Mass Spectrometry (SPME-GC/MS) analysis of aromatic constituents deposited onto the tobacco during the infusion process.

15

Table 1

Sample	Description of sample
Juniper 1	2 kg juniper berry milled from frozen, heated to 90°C using the apparatus shown in Figure 4 with 10 kg tobacco
Juniper 2	2 kg juniper berry milled from frozen heated to 90°C using the apparatus shown in Figure 3 with 10 kg tobacco
Juniper 3	The tobacco which had been impregnated in Juniper 1 was impregnated by an additional 2 kg juniper berry milled from frozen heated to 90°C using the apparatus shown in Figure 4.
Juniper 4	The tobacco which had been impregnated in Juniper 2 was impregnated by an additional 2 kg juniper berry milled from frozen heated to 90°C using the apparatus shown in Figure 4.
Juniper control sample	Ground juniper berry – no tobacco.

As can be seen from Table 2 constituents present in the juniper control sample and absent from the tobacco control sample are present in the samples Juniper 1-4 prepared in accordance with the present invention.

Claims

1. Apparatus for impregnating a tobacco industry product with a sensate constituent of a botanical, the apparatus comprising a first portion for receiving the tobacco industry product and a second portion for receiving the botanical,
5 wherein the tobacco industry product becomes impregnated by the sensate constituent of the botanical when the first portion is pressurised and the sensate constituent is released into the first portion.
- 10 2. Apparatus according to claim 1, wherein the second portion is located within the first portion.
3. Apparatus according to claim 2, wherein the second portion is located along a central axis of the first portion.
- 15 4. Apparatus according to claim 2 or claim 3, wherein the second portion comprises at least one mesh container.
5. Apparatus according to claim 4, wherein the mesh container has a mesh size of
20 between 200 and 250 microns.
6. Apparatus according to claim 1, wherein the second portion is external to and connected to the first portion.
- 25 7. Apparatus according to claim 6, wherein the second portion is configured to store the botanical in gaseous form.
8. Apparatus according to any preceding claim, wherein the first portion is pressurised to a pressure in a range between approximately 18 and 25 pounds per square inch.
- 30 9. Apparatus according to any preceding claim further comprising a heat source to supply heat to the first portion and optionally to the second portion.
10. Apparatus according to claim 9, wherein the first portion and optionally the second
35 portion are heated to a temperature in a range between 20 and 45 degrees Celsius.

11. Apparatus for impregnating a tobacco industry product with a sensate constituent of a botanical, the apparatus comprising:
a botanical storage chamber;
a vapour source; and
5 a tobacco storage chamber,
wherein the vapour source is disposed relative to the botanical storage chamber so that, in use, vapour passes through botanicals stored in the botanical storage chamber and impregnates tobacco stored in the tobacco storage chamber with sensate constituents of the botanical.
- 10 12. Apparatus according to claim 11, wherein the vapour source comprises a water receptacle containing water and a heat source applied thereto.
13. Apparatus according to either claim 11 or claim 12, wherein the botanical storage
15 chamber is heated to 90°C.
14. Apparatus according to any of claims 11 to 13, wherein the tobacco is stored in a rotary drum.
- 20 15. Apparatus according to any preceding claim, wherein the botanical is one of the following: coffee, juniper, menthol, anise.
16. Apparatus according to any preceding claim, wherein the tobacco industry product is one of the following: cut tobacco, snus, filter paper, filtration material, smoking articles,
25 smoking article containers or blanks for forming smoking article containers.
17. A method for impregnating a tobacco industry product with a sensate constituent of an botanical, the method comprising:
storing the tobacco industry product in a first portion of an apparatus and storing
30 the botanical in a second portion of an apparatus;
pressurising the first portion so that the tobacco industry product becomes susceptible to impregnation by the sensate constituent of the botanical; and
releasing the sensate constituent into the first portion so that the tobacco industry product and the sensate constituent come into contact.
- 35

18. A method according to claim 17, wherein the second portion is located within the first portion.
19. A method according to claim 18, wherein the second portion is located along a
5 central axis of the first portion.
20. A method according to either claim 18 or claim 19, wherein the second portion comprises at least one mesh container.
- 10 21. A method according to claim 20, wherein the mesh container has a mesh size of between 200 and 250 microns.
22. A method according to claim 17, wherein the second portion is external to and connected to the first portion.
- 15 23. A method according to claim 17 or claim 22, wherein the second portion is a container for storing the botanical in gaseous form.
24. A method according to any of claims 17-23, wherein the first portion is pressurised
20 to a pressure in a range between approximately 18 and 25 pounds per square inch.
25. A method according to any of claims 17-24 further comprising supplying heat to the first portion and optionally to the second portion.
- 25 26. A method according to claim 25, wherein the first portion and optionally the second portion are heated to a temperature in a range between 20 and 45 degrees Celsius.
27. A method of impregnating a tobacco industry product with a sensate constituent of a botanical, the method comprising:
30 passing vapour through a botanical product and subsequently mixing the vapour with the tobacco industry product so that it becomes impregnated with the sensate constituent of the botanical.
28. A method according to claim 27, comprising heating the botanical product to 90°C.
35

29. A method according to either claim 27 or claim 28, further comprising rotating the tobacco industry product in a rotary drum.

30. A method according to any of claims 17-29, wherein the at least one variety of
5 botanical includes coffee, juniper, menthol or anise.

31. A method according to any of claims 17-30, wherein the tobacco industry product is one of cut tobacco, snus, filter paper, filtration material, smoking articles, smoking article containers or blanks for forming smoking article containers.

10

32. A method or apparatus as described in the foregoing description with reference to the accompanying drawings.

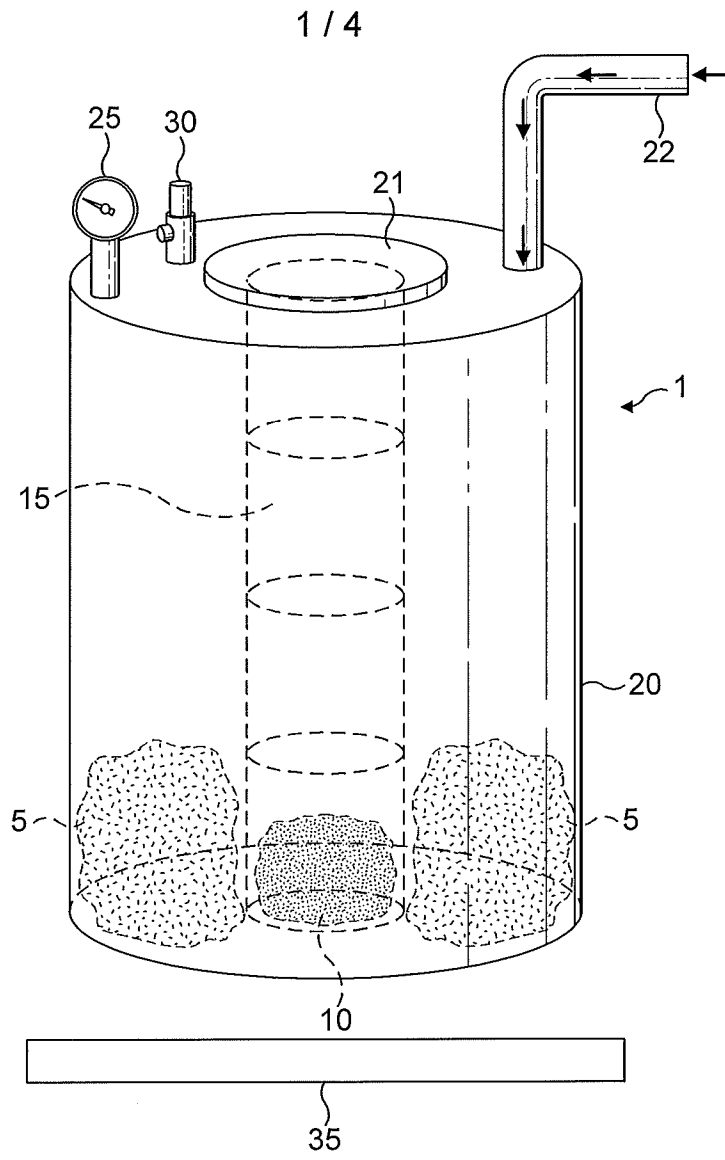

FIG. 1

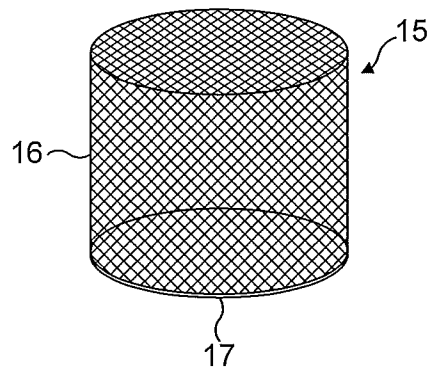

FIG. 2

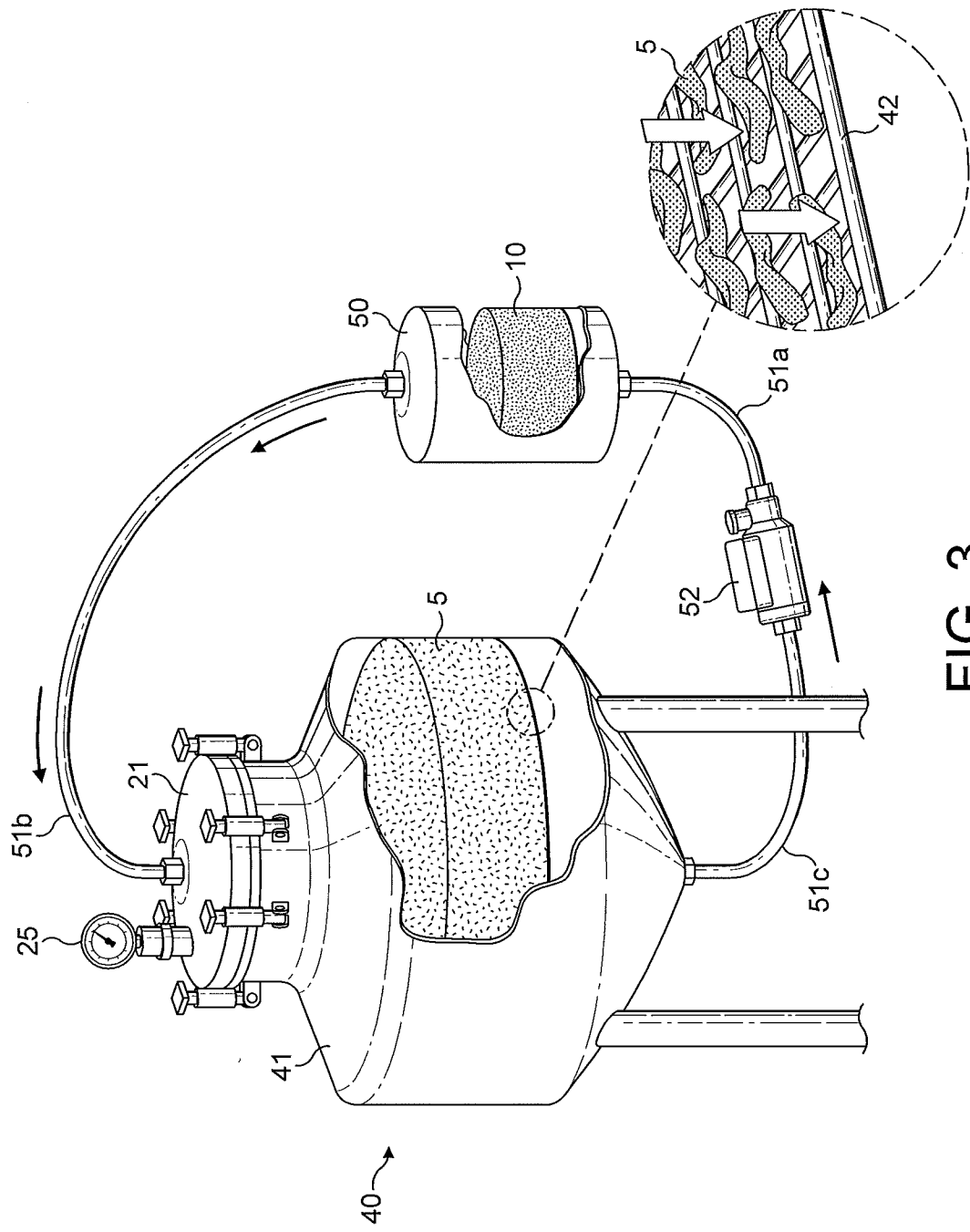

FIG. 3

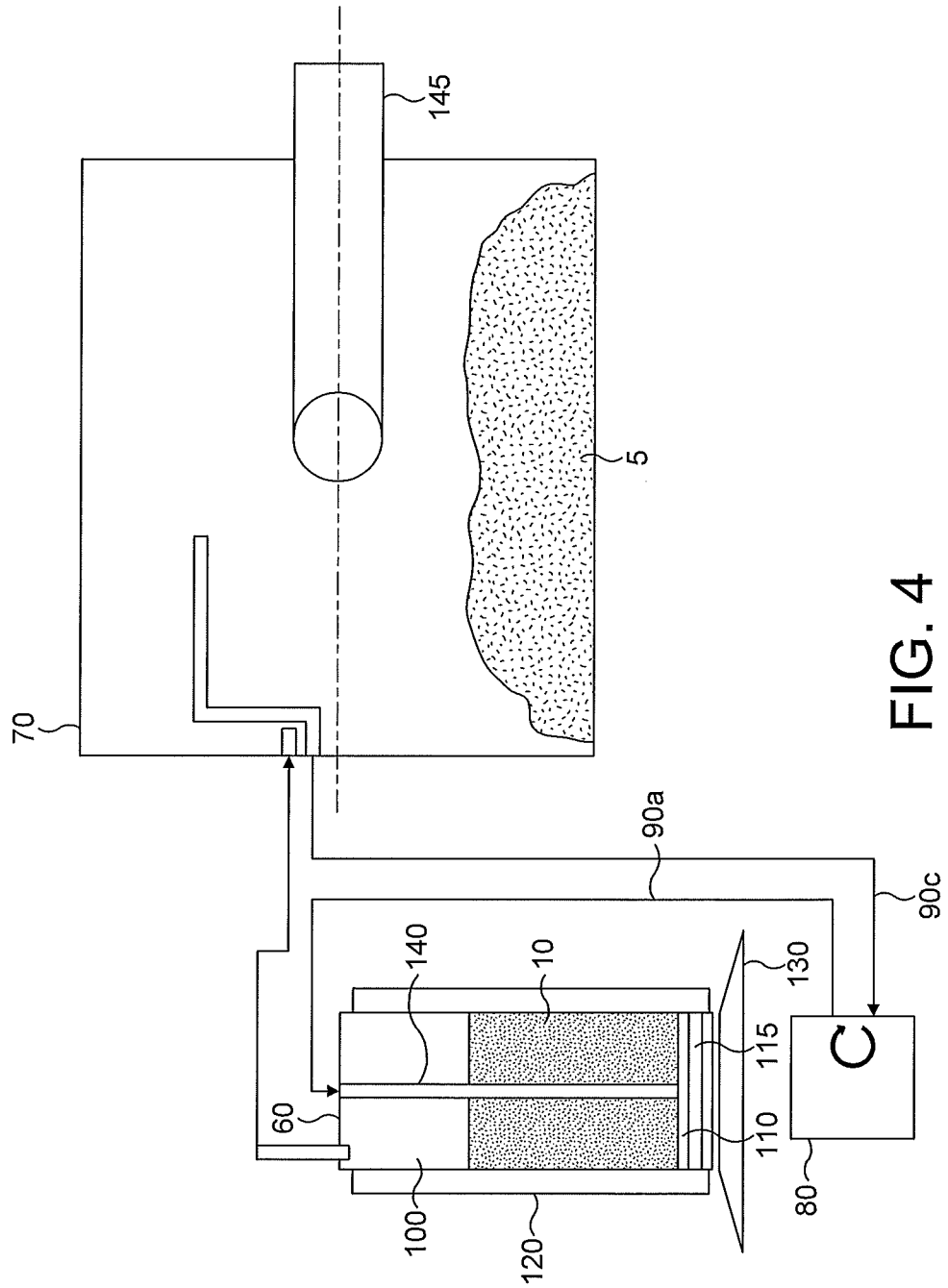

FIG. 4

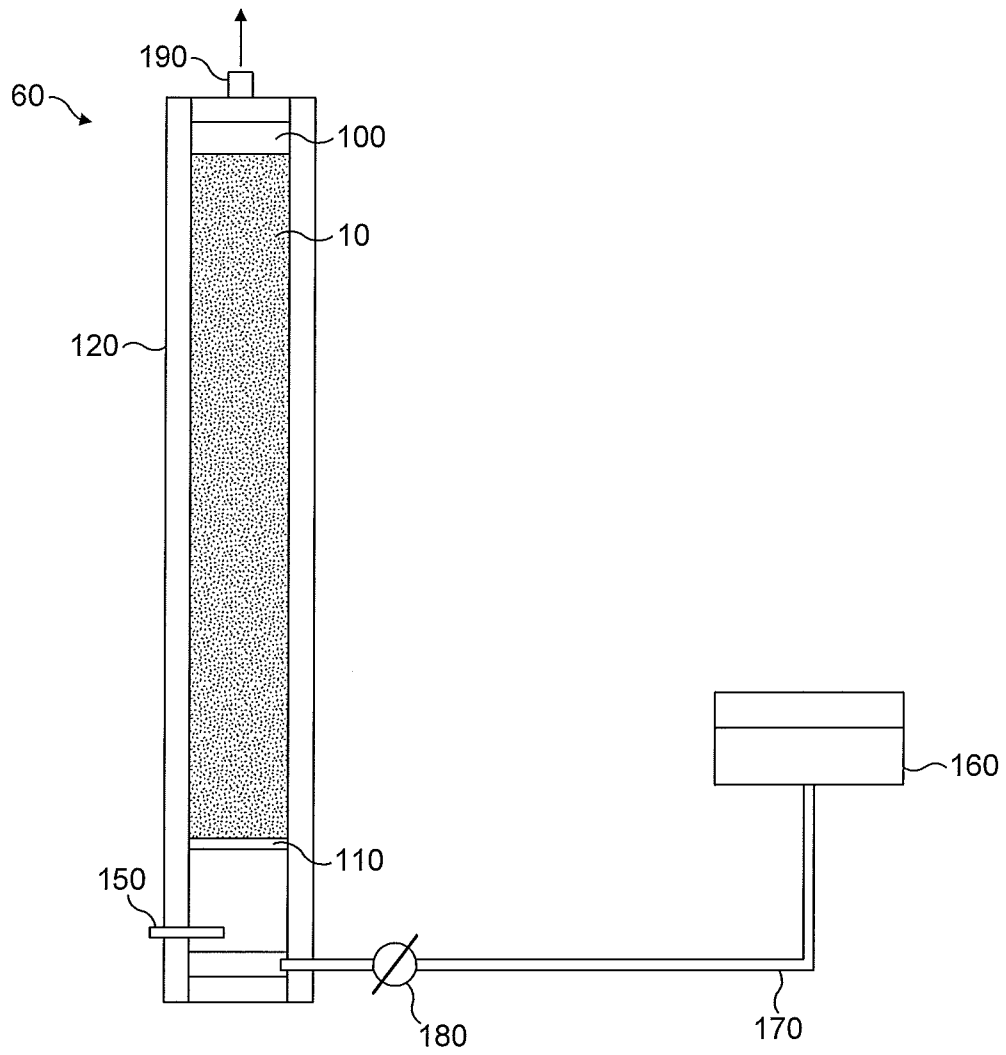

FIG. 5