



(12) **EUROPEAN PATENT APPLICATION**

(43) Date of publication: **03.08.2005 Bulletin 2005/31** (51) Int Cl.7: **F02M 61/12, F02M 61/16**

(21) Application number: **04001803.8**

(22) Date of filing: **28.01.2004**

(84) Designated Contracting States:  
**AT BE BG CH CY CZ DE DK EE ES FI FR GB GR  
HU IE IT LI LU MC NL PT RO SE SI SK TR**  
Designated Extension States:  
**AL LT LV MK**

• **Mariani, Giuseppe**  
**57128 Livorno (IT)**

(74) Representative: **Berg, Peter, Dipl.-Ing.**  
**European Patent Attorney,**  
**Siemens AG,**  
**Postfach 22 16 34**  
**80506 München (DE)**

(71) Applicant: **Siemens VDO Automotive S.p.A.**  
**56040 Fauglia (Pisa) (IT)**

(72) Inventors:  
• **D'Arrigo, Angelo**  
**57013 Rosignano Solvay (IT)**

Remarks:  
Amended claims in accordance with Rule 86 (2)  
EPC.

(54) **Fluid injector with means to prevent rotation of the valve needle**

(57) The fluid injector has a housing, an actuator unit and a valve body. The valve body has a cartridge (21) with a recess (211), that forms an injection nozzle (213), if it rests with its seat area on a needle seat of the cartridge. A further recess (217) or raised area in the cartridge (21), a holding element and a recess (226) or raised area in the needle (22) are formed and arranged in a way, that they cooperate to fix the needle (22) in its rotational position relative to the cartridge (21).

**FIG 3**

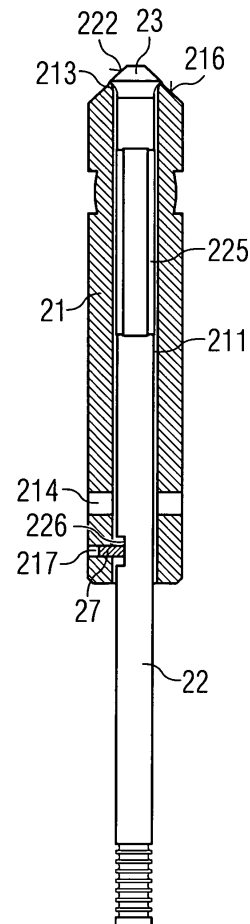

**Description**

**[0001]** The invention relates to a valve body, a fluid injector and a method for manufacturing the fluid injector. The valve body comprises a cartridge with a recess, that forms an injection nozzle on one end, and comprises a needle, which is arranged in the recess, and closes the injection nozzle, if it rests with its seat area on a needle seat of the cartridge.

**[0002]** Fluid injectors, in particular fuel injectors for diesel or gasoline internal combustion engines, comprise a housing, an actuator unit and a valve body. The valve body comprises a needle that opens or closes a nozzle and in that way controls the injection of fuel. In an increasing number of applications actuator units with a piezoelectric actuator are used. They have the advantage of having a very fast response time to actuating signals and enable like that multiple injections into a cylinder of the internal combustion engine during one working cycle of the cylinder. In order to improve the spray characteristics of the fluid injector the fluid pressure is increased. In current gasoline internal combustion engines the fluid injectors are supplied with fuel which has a pressure of up to 200 bars.

**[0003]** WO 03/016707 A1 discloses a fluid injector with a connector to a fuel supply, a housing, an actuator unit, and a valve body. The housing is double tubed and has a recess, which takes up the actuator unit. The actuator unit comprises a piezoelectric actuator, which acts on the needle. Between the walls of the double tube-shaped housing the fuel is led from the connector to a fuel inlet of the valve body. The valve body has a housing part with a recess, that takes up a needle. Depending on the position of the needle a nozzle is opened or closed and respectively fuel is injected or not.

**[0004]** Increasingly strict legislation concerning emissions of internal combustion engines, where a valve body or a fluid injector with valve body is arranged, make it necessary to put a lot of effort in measures, that reduce the emissions. Very important for the prevention of exhaust emissions is, that fluid injectors used for the internal combustion engine have a defined and constant spray characteristic.

**[0005]** In order to achieve such a defined and constant spray characteristic it is known to provide the areas of the needle and the cartridge adjacent to the injection nozzle with a very precise finish by a grinding process, for example by lapping. By doing this the buildup of coking is prevented and that way the constant spray characteristic can be ensured.

**[0006]** The object of the invention is to create a valve body, a fluid injector and a method for manufacturing the fluid injector, which is simple and enables a precise manufacture of the valve body or respectively the fluid injector.

**[0007]** The object is achieved by the features of the independent claims. Advantageous embodiments of the invention are given in the subclaims.

**[0008]** The invention concerning the valve body is distinguished by a valve body with a cartridge with a recess, that forms an injection nozzle on one end and with a needle, that is arranged in the recess and closes the injection nozzle, if it rests with its seat area on a needle seat of the cartridge. The cartridge comprises a further recess or a raised area. In addition to that the valve body is provided with a holding element and with a recess or a raised area in the needle. The further recess or raised area in the cartridge, the holding element and the recess or raised area in the needle are formed and arranged in a way, that they cooperate to fix the needle in its rotational position relative to the cartridge.

**[0009]** In that way the grinding of the areas of the needle and the cartridge facing outwards from the valve body and being located adjacent to the injection nozzle can be done without much effort as the needle cannot change its rotational position relative to the cartridge. During the operation of the valve body the needle is fixed in a simple way in its rotational position and that way the areas adjacent to the injection nozzle, which have been grinded during the manufacturing process, stay aligned, which prevents effectively the buildup of coking. In addition to that the needle is prevented from falling out of the cartridge during the assembly process, if the further recess or raised area in the cartridge, the holding element and the recess or raised area in the needle are suitably formed.

**[0010]** In an advantageous embodiment of the valve body the holding element is arranged further away from the injection nozzle than a fluid inlet in the cartridge. This has the advantage, that the holding element does not interfere with the fluid flowing towards the injection nozzle.

**[0011]** In a further advantageous embodiment of the valve body the holding element is a pin. This has the advantage that pins are widely and cheaply available.

**[0012]** In another advantageous embodiment of the valve body the holding element is ring-shaped. A ring-shaped holding element does not necessarily have to be a full ring, it may also be a section of a ring or a ring comprising a slot. Such ring-shaped holding elements are widely and cheaply available. In combination with the holding element being arranged further away from the injection nozzle than a fluid inlet the ring-shaped holding element dampens fluid pressure pulsations, which relieves respective parts located even further away from the injection nozzle than the holding element.

**[0013]** In a further advantageous embodiment of the valve body the recess or raised area in the needle is a blind hole. This has the advantage, that a blind hole is simple to manufacture and efficiently ensures, in cooperation with the holding element, that the needle cannot fall out.

**[0014]** In a further advantageous embodiment of the valve body the recess or raised area in the needle is formed as a flattening of a section of the cross-section of the needle. This has the advantage, that it is simple to manufacture.

**[0015]** In a further advantageous embodiment of the valve body, the recess or raised area in the cartridge is formed in such a way, that the holding element fixes the needle in the area of an end of the cartridge away from the injection nozzle. In this advantageous embodiment of the valve body the holding element can simply be, for example, axially pushed on the cartridge and there is no need for a passage through the cartridge for the holding element, which decreases the costs for manufacturing the device.

**[0016]** A fluid injector with a housing, an actuator unit and the valve body has the same advantages as the valve body itself.

**[0017]** The method for manufacturing the fluid injector is distinguished by the following steps. The needle is inserted in the cartridge. After that the needle seat of the cartridge and the seat area of the needle are grinded. This is preferably achieved by a lapping process, where the needle and the cartridge are rotated relatively to each other. After that the holding element is inserted and in that way the needle is fixed in its position relative to the cartridge for the next steps. Then the area of the needle and cartridge facing outwards from the injection nozzle and being adjacent to the injection nozzle are being grinded together. By this the areas are brought into very precise alignment to each other, which prevents buildup of coking during the operation of the valve body. After that the valve body is assembled with the housing. It may, for example, be fixed to the housing by welding. During the grinding process of the two areas of the needle and the cartridge it is not necessary to fix the rotational position of the needle by a special tool. It is advantageous to keep the holding element inside the valve body in the assembled fluid injector.

**[0018]** Exemplary embodiments of the invention are explained in the following with the aid of schematic drawings. These are as follows:

- Figure 1 a fluid injector,
- Figure 2 a valve body,
- Figure 3 an axial section of the valve body according to Figure 2,
- Figure 4 a cartridge and a needle of the valve body in an disassembled way,
- Figure 5 a second embodiment of the valve body in an axial section,
- Figure 6 the holding element for the valve body according to Figure 5, and
- Figures 7A, B, C, D different cross-sections of the needle in the area of the recess or the raised area of the needle.

**[0019]** Elements of the same design and function that occur in different illustrations are identified by the same reference character.

**[0020]** A fluid injector, that is used as a fuel injector for an internal combustion engine, comprises a housing 1 (Figure 1), a valve body 2, an actuator unit 3 and a fuel connector 4. The fuel connector 4 is designed to be connected to a high pressure fuel chamber of the internal combustion engine, where fuel is stored under high pressure, for example under the pressure of about 200 Bar.

**[0021]** The housing 1 is preferably formed out of a double-tubed housing. In the space between the walls of the double-tubed housing the fuel is led from the fuel connector to a fuel inlet 214 of the valve body 2.

**[0022]** The valve body 2 comprises a cartridge 21, which is permanently fixed to the housing 1 at one of its free ends, preferably by welding, especially laser-welding. The cartridge 21 comprises a recess 211 (Figure 2) which forms at one of its ends an injection nozzle 213 and which takes in a needle 22.

**[0023]** A spring rest 24 is connected to the needle 22. A return spring 25 rests on the spring rest 24 and pretensions the needle 22 in a direction away from the injection nozzle 213. In that way the needle 22 closes the injection nozzle 213, if no further external forces act on the needle 22.

**[0024]** The fuel is led from the fuel inlet 214 in the space between the needle 22 and the wall of the recess 213 of the cartridge 21 to the injection nozzle 213. The needle 22 further comprises a guided zone 221, by which the needle 22 is guided within the recess 213.

**[0025]** In the position where the needle 22 closes the injection nozzle 213 the needle 22 rests with its seat area 224 on a needle seat 215 of the cartridge 21. The needle seat 215 and the seat area 224 are conically shaped in a preferred embodiment. This enables to set a desired spray angle.

**[0026]** Areas of the needle 22 and the cartridge 21 facing outwards from the injection nozzle 213 and being adjacent to the injection nozzle 213 are in a preferred embodiment conically shaped and are named in the following conically-shaped area 216 of the cartridge 21 and conically-shaped area 222 of the needle 22. These two conically-shaped areas 216 and 222 need to be precisely aligned in order to prevent the buildup of coking, which decreases the spray quality of the fuel injector. In order to achieve such a precise alignment, the conically-shaped areas 216 and 222 are grinded together which is described in detail below.

**[0027]** The cartridge 21 comprises a further recess 217 or a raised area in the embodiment according to Figure 3. This further recess 217 is formed as a hole, that passes from the outside of the cartridge 21 through the cartridge to

a recess 211. The recess 211 is called the in the following first recess 211 and the further recess is called second recess 217.

[0028] The needle 22 comprises a recess 226. The recess 226 in the needle 22 is formed as a flattening of a section of the cross-section of the needle 22 (Figure 4). A holding element, that is a pin 27, is inserted in the second recess 217 and projects into the recess 226 of the needle 22. The recess 226 of the needle 22 has an axial length, that ensures, that the needle 22 can be axially moved by the actuator unit 3 and the return spring 25 as intended. The pin 27 cooperates with the second recess 217 and the recess 226 of the needle 22 to fix the needle 22 in its rotational position relative to the cartridge.

[0029] The second recess 217 of the cartridge 21 is arranged further away from the injection nozzle 213 than a fuel inlet 214. In that way the fuel can flow from the fuel inlet 214 towards the injection nozzle 213 without facing a hydraulic resistance caused by an obstacle like the pin 27.

[0030] Figure 4 shows a first step of a manufacturing process for a second embodiment of the fluid injector. The cartridge 21 has a differently formed second recess 217'. The second recess 217' is formed in the area of an end of the cartridge 21, which is located in the area of the second free end of the first recess 211 with the first free end of the first recess 211 being the injection nozzle 213. In the manufacturing step shown in Figure 4 the needle 22 is inserted into the first recess 211. After that the needle seat 215 of the cartridge 21 and the seat area 224 of the needle 21 are grinded. This grinding process preferably includes a lapping process. For the lapping process a paste or fluid is used which contains the cutting material. During the lapping process the needle 22 and the cartridge 21 are rotated relatively to each other. By this a very precise finish of the needle seat 215 and the seat area 224 is achieved.

[0031] In the next manufacturing step (Figure 5) the holding element, which is a ring-shaped element 28 is inserted axially as shown by the arrows of Figure 5. The ring-shaped element 28 (Figure 6) is preferably generally ring-shaped but has a slot which increases flexibility of the ring-shaped element 28 and enables it to be used as a clip element, which is clipped into the recess 226 of the needle 22 and is pushed into the second recess 217. It has contours that match the contour of the second recess 217 of the cartridge 21 and the contour of the recess 226 of the needle 22. In its assembled state the ring-shaped element 28 fills out a great part of the space between the needle 22 and the wall of the first recess 211 of the cartridge 21. In that way the ring-shaped element 28 has on one hand the function to prevent a rotational movement of the needle 22 relative to the cartridge 21 and on the other hand it dampens effectively pressure waves, which travel along the first recess from the injection nozzle 213 towards the ring-shaped element. This dampening effect relieves parts located even further away from the injection nozzle like a bellow or the actuator unit 3.

[0032] After the ring-shaped element 28 is inserted in the recess 226 of the needle 22 and the second recess 217' of the cartridge 21 the conically-shaped areas 216, 222 are grinded together in order to get them precisely aligned. This grinding process preferably includes a honing process and/or a lapping process. In the honing process the grinding wheel makes, for example, an oscillatory movement, oscillating between the needle 22 and the cartridge 21. At the same the needle 22 and the cartridge 21 are turned around their axes. The grinding process may further include a lapping process. After having finished the grinding process the conically-shaped areas 216, 222 precisely match each other.

[0033] After the valve body is fully assembled it is preferably welded to the housing 1, the holding element may be kept in the valve body or may also be taken out. Preferably it is left in the valve body, which then ensures during the operation of the injection valve, that there is no rotational movement between the needle 22 and the cartridge 21.

[0034] Figure 7A shows an embodiment of the needle, with the recess 227 being formed as a blind hole, which is simple to manufacture and ensures in cooperation with the holding element, that the needle 22 is tightly fixed in its rotational position relative to the cartridge 21. In another embodiment of the needle 22 (Figure 7B) the recess 228 is formed as a sector. In a further embodiment of the needle 22 the recess 229 is formed in a sinusoidal shape. In another embodiment of the needle 22 there is a raised area 229A. The holding elements, that cooperate with the different forms of the recess 227, 228, 229 or the raised area 229A are formed respectively to enable a rotational fixation of the position of the needle 22. Instead of having the second recess 217', 217 there may also be a raised area which cooperates with the holding element.

## Claims

1. Valve body with a cartridge (21) with a recess (211), that forms an injection nozzle (213) on one end and with a needle (22), that is arranged in the recess (211) and closes the injection nozzle (213) if it rests with its seat area (224) on a needle seat (215) of the cartridge (21),
  - with a further recess (217, 217') or raised area in the cartridge (21),
  - with a holding element and

- with a recess (226, 227, 228, 229) or a raised area (229A) in the needle (22),
- with the further recess (217, 217') or raised area in the cartridge (21), the holding element and the recess (226, 227, 228, 229) or raised area (229A) in the needle (22) being formed and arranged in a way, that they cooperate to fix the needle (22) in its rotational position relative to the cartridge.

- 5
2. Valve body in accordance with claim 1 with the holding element being arranged further away from the injection nozzle than a fluid inlet.
- 10
3. Valve body in accordance with one of the preceding claims with the holding element being a pin (27).
4. Valve body in accordance with one of the preceding claims with the holding element being a ring-shaped element (28).
- 15
5. Valve body in accordance with one of the preceding claims with the recess (226, 227, 228, 229) or raised area (229A) in the needle (22) being a blind hole.
6. Valve body in accordance with one of the preceding claims with the recess (226, 227, 228, 229) or raised area (229A) in the needle being formed as a flattening of a section of the cross-section of the needle (22).
- 20
7. Valve body in accordance with one of the preceding claims with the recess (217, 217') or raised area in the cartridge (21) being formed in such a way that the holding element fixes the needle (22) in the area of an end of the cartridge (21) away from the injection nozzle (213).
- 25
8. Fluid injector with a housing (1), an actuator unit (3) and a valve body (2) in accordance with one of the preceding claims.
9. Method for manufacturing an injector in accordance with claim 8 with the following steps:
- 30
- inserting the needle (22) in the cartridge (21),
  - grinding the needle seat (215) and the seat area (224) of the needle (22),
  - inserting the holding element,
  - grinding the area of the needle (22) and the cartridge (21) facing outwards from the injection nozzle (213) and being adjacent to the injection nozzle (213), and
  - assembling the valve body (2) with the housing (1).
- 35

**Amended claims in accordance with Rule 86(2) EPC.**

40

1. Valve body with a cartridge (21) with a recess (211), that forms an injection nozzle (213) on one end and with a needle (22), that is arranged in the recess (211) and closes the injection nozzle (213) if it rests with its seat area (224) on a needle seat (215) of the cartridge (21),

- with a further recess (217, 217') or raised area in the cartridge (21),
- with a holding element and
- with a recess (226, 227, 228, 229) or a raised area (229A) in the needle (22),
- with the further recess (217, 217') or raised area in the cartridge (21), the holding element and the recess (226, 227, 228, 229) or raised area (229A) in the needle (22) being formed and arranged in a way, that they cooperate to fix the needle (22) in its rotational position relative to the cartridge,

50

**characterized in that** the holding element is a ring-shaped element (28).

2. Valve body in accordance with claim 1,  
**characterized in that** the holding element is arranged further away from the injection nozzle than a fluid inlet.

55

3. Valve body in accordance with one of the preceding claims,  
**characterized in that** the recess (226, 227, 228, 229) or raised area (229A) in the needle (22) is a blind hole.

4. Valve body in accordance with one of the preceding claims,

**characterized in that** the recess (226, 227, 228, 229) or raised area (229A) in the needle is formed as a flattening of a section of the cross-section of the needle (22).

5 **5.** Valve body in accordance with one of the preceding claims,  
**characterized in that** the recess (217, 217') or raised area in the cartridge (21) is formed in such a way that the holding element fixes the needle (22) in the area of an end of the cartridge (21) away from the injection nozzle (213).

10 **6.** Fluid injector with a housing (1), an actuator unit (3) and a valve body (2) in accordance with one of the preceding claims.

**7.** Method for manufacturing an injector in accordance with claim 6 with the following steps:

- inserting the needle (22) in the cartridge (21),
- grinding the needle seat (215) and the seat area (224) of the needle (22),
- 15 - inserting the holding element,
- grinding the area of the needle (22) and the cartridge (21) facing outwards from the injection nozzle (213) and being adjacent to the injection nozzle (213), and
- assembling the valve body (2) with the housing (1).

20

25

30

35

40

45

50

55

FIG 1

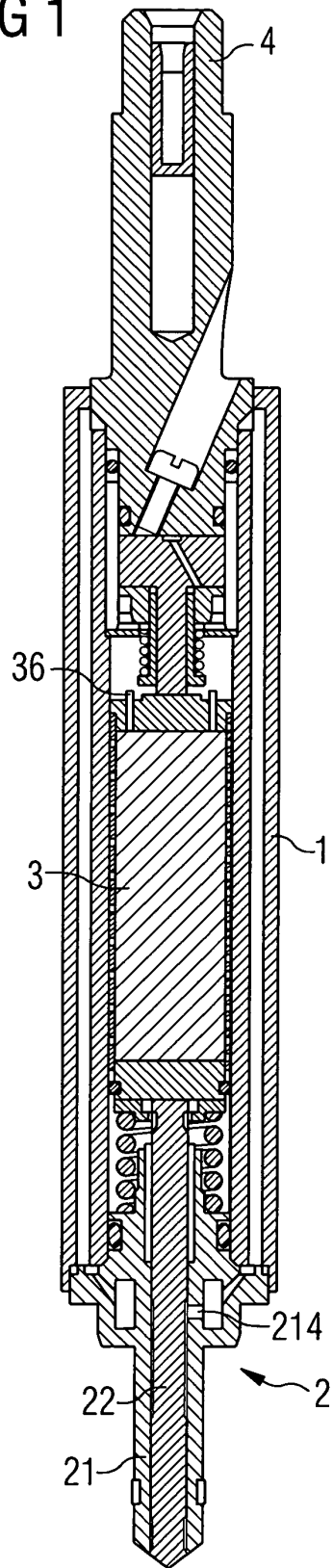

FIG 2

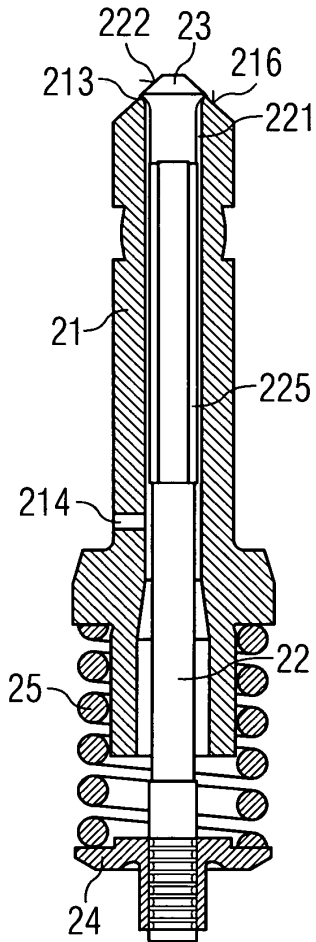

FIG 3

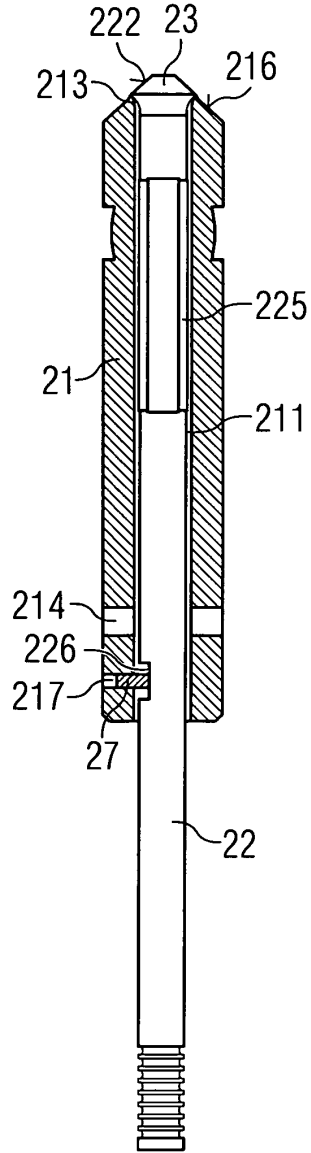

FIG 4

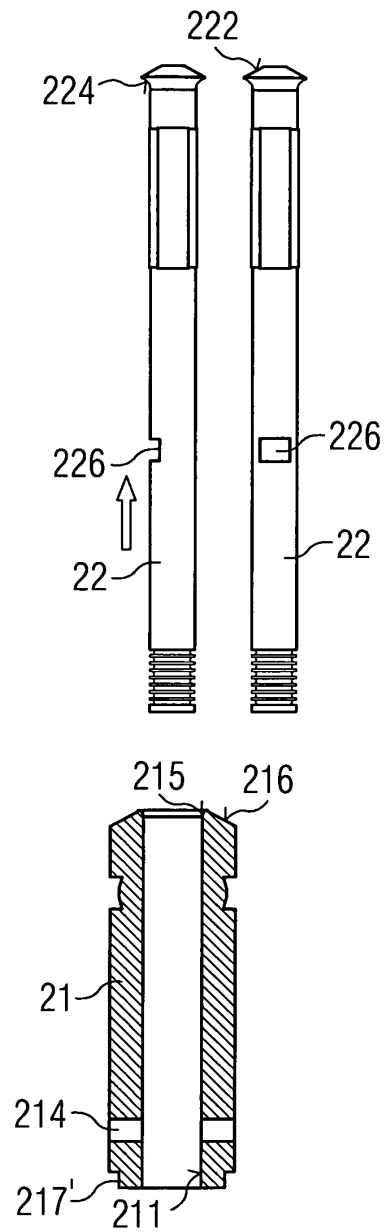

FIG 5

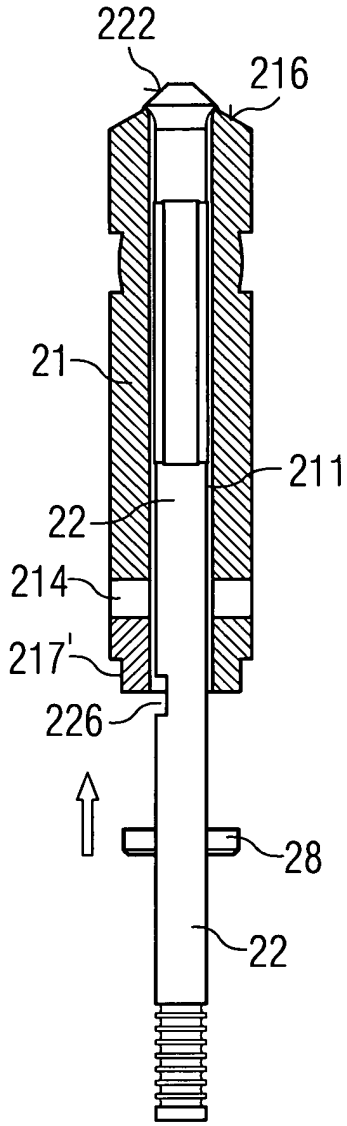

FIG 6

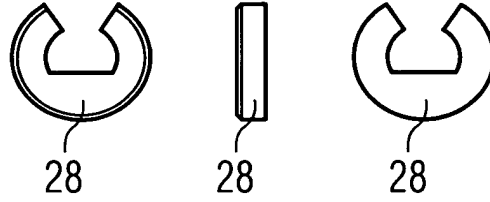

FIG 7A

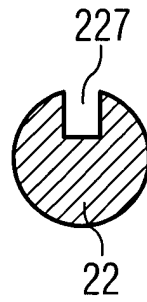

FIG 7B

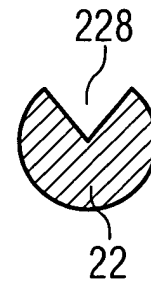
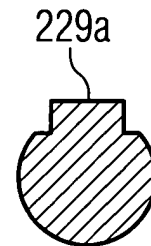

FIG 7C



FIG 7D





DOCUMENTS CONSIDERED TO BE RELEVANT			
Category	Citation of document with indication, where appropriate, of relevant passages	Relevant to claim	CLASSIFICATION OF THE APPLICATION (Int.Cl.7)
X	EP 0 512 598 A (GEN MOTORS CORP) 11 November 1992 (1992-11-11) * column 4, line 52 - column 5, line 5; figures 1-3 *	1-9	F02M61/12 F02M61/16
X	--- US 4 382 554 A (HOFMANN KARL) 10 May 1983 (1983-05-10) * column 6, line 31 - column 6, line 35; figures 1,3 *	1-9	
A	--- US 6 199 539 B1 (TKAC RONALD MICHAEL ET AL) 13 March 2001 (2001-03-13) * figures 1-3 *	1	
A	--- EP 1 041 274 A (ARIMOTO JUN) 4 October 2000 (2000-10-04) * abstract *	1	
A	--- US 2002/100822 A1 (OLIVER JACK DAVID) 1 August 2002 (2002-08-01) * figures 1,2 *	1	
	-----		TECHNICAL FIELDS SEARCHED (Int.Cl.7) F02M
The present search report has been drawn up for all claims			
Place of search MUNICH		Date of completion of the search 18 March 2004	Examiner Jackson, S
CATEGORY OF CITED DOCUMENTS X : particularly relevant if taken alone Y : particularly relevant if combined with another document of the same category A : technological background O : non-written disclosure P : intermediate document		T : theory or principle underlying the invention E : earlier patent document, but published on, or after the filing date D : document cited in the application L : document cited for other reasons ----- & : member of the same patent family, corresponding document	

2

EPO FORM 1503 03.82 (P04C01)

**ANNEX TO THE EUROPEAN SEARCH REPORT  
ON EUROPEAN PATENT APPLICATION NO.**

EP 04 00 1803

This annex lists the patent family members relating to the patent documents cited in the above-mentioned European search report. The members are as contained in the European Patent Office EDP file on  
The European Patent Office is in no way liable for these particulars which are merely given for the purpose of information.

18-03-2004

Patent document cited in search report		Publication date	Patent family member(s)	Publication date
EP 0512598	A	11-11-1992	US 5127584 A	07-07-1992
			DE 69200567 D1	01-12-1994
			DE 69200567 T2	02-03-1995
			EP 0512598 A1	11-11-1992
			JP 5141325 A	08-06-1993
-----				
US 4382554	A	10-05-1983	DE 3036583 A1	13-05-1982
			GB 2084248 A ,B	07-04-1982
			JP 57086558 A	29-05-1982
-----				
US 6199539	B1	13-03-2001	AU 7199600 A	03-01-2002
			BR 0100500 A	05-03-2002
			CA 2351205 A1	22-12-2001
			EP 1167752 A2	02-01-2002
			JP 2002021681 A	23-01-2002
-----				
EP 1041274	A	04-10-2000	WO 0022295 A1	20-04-2000
			EP 1041274 A1	04-10-2000
			US 2002092929 A1	18-07-2002
-----				
US 2002100822	A1	01-08-2002	NONE	
-----				