

(19) World Intellectual Property Organization
International Bureau



(43) International Publication Date
11 August 2011 (11.08.2011)

(10) International Publication Number
WO 2011/095979 A1

- (51) International Patent Classification:
A61F 2/06 (2006.01)
- (21) International Application Number:
PCT/IL2011/000135
- (22) International Filing Date:
8 February 2011 (08.02.2011)
- (25) Filing Language: English
- (26) Publication Language: English
- (30) Priority Data:
61/302,184 8 February 2010 (08.02.2010) US
- (71) Applicant (for all designated States except US): EN-DOSPAN LTD. [IL/IL]; 4 Maskit St., P.O. Box 12058, 46733 Herzilyia Pituach (IL).
- (72) Inventor; and
- (75) Inventor/Applicant (for US only): SHALEV, Alon [IL/IL]; 9 Wingate St., 43587 Ra'anana (IL).
- (74) Agent: DR. EYAL BRESSLER LTD.; 11 Tuval St., Lazrom House, 52522 Ramat Gan (IL).
- (81) Designated States (unless otherwise indicated, for every kind of national protection available): AE, AG, AL, AM, AO, AT, AU, AZ, BA, BB, BG, BH, BR, BW, BY, BZ, CA, CH, CL, CN, CO, CR, CU, CZ, DE, DK, DM, DO, DZ, EC, EE, EG, ES, FI, GB, GD, GE, GH, GM, GT, HN, HR, HU, ID, IL, IN, IS, JP, KE, KG, KM, KN, KP, KR, KZ, LA, LC, LK, LR, LS, LT, LU, LY, MA, MD, ME, MG, MK, MN, MW, MX, MY, MZ, NA, NG, NI, NO, NZ, OM, PE, PG, PH, PL, PT, RO, RS, RU, SC, SD, SE, SG, SK, SL, SM, ST, SV, SY, TH, TJ, TM, TN, TR, TT, TZ, UA, UG, US, UZ, VC, VN, ZA, ZM, ZW.
- (84) Designated States (unless otherwise indicated, for every kind of regional protection available): ARIPO (BW, GH, GM, KE, LR, LS, MW, MZ, NA, SD, SL, SZ, TZ, UG, ZM, ZW), Eurasian (AM, AZ, BY, KG, KZ, MD, RU, TJ, TM), European (AL, AT, BE, BG, CH, CY, CZ, DE, DK, EE, ES, FI, FR, GB, GR, HR, HU, IE, IS, IT, LT, LU, LV, MC, MK, MT, NL, NO, PL, PT, RO, RS, SE, SI, SK,

[Continued on next page]

(54) Title: THERMAL ENERGY APPLICATION FOR PREVENTION AND MANAGEMENT OF ENDOLEAKS IN STENT-GRAFTS

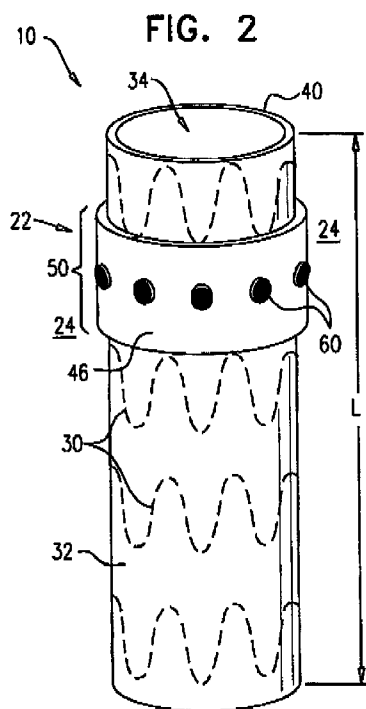

(57) Abstract: Apparatus (10) is provided, which includes an endovascular stent-graft (20) and a heating device (22) that is coupled to the stent-graft (20). The stent-graft (20) is configured to be implanted in at least one blood vessel in a vicinity of an aneurysm (102). The heating device (22) is configured to apply, to a region (24) external to the stent-graft (20), thermal energy sufficient to coagulate blood flowing into the aneurysm (102). Other embodiments are also described.

SM, TR), OAPI (BF, BJ, CF, CG, CI, CM, GA, GN, GQ, GW, ML, MR, NE, SN, TD, TG). **Published:**

Declarations under Rule 4.17:

— *as to applicant's entitlement to apply for and be granted a patent (Rule 4.17(ii))*

— *with international search report (Art. 21(3))*

— *before the expiration of the time limit for amending the claims and to be republished in the event of receipt of amendments (Rule 48.2(h))*

THERMAL ENERGY APPLICATION FOR PREVENTION AND MANAGEMENT OF
ENDOLEAKS IN STENT-GRAFTS

CROSS-REFERENCE TO RELATED APPLICATIONS

The present patent application claims priority from US Provisional Application
5 61/302,184, filed February 8, 2010, entitled, "Methods and devices for the prevention and
management of endoleaks in stent-grafts," which is assigned to the assignee of the present
application and incorporated herein by reference.

FIELD OF THE APPLICATION

This present application relates generally to prostheses and treatment methods, and
10 specifically to tubular prostheses, including endovascular grafts and stent-grafts, and
treatment techniques for using the prostheses to maintain patency of body passages such
as blood vessels, and treating aneurysms.

BACKGROUND OF THE APPLICATION

Endovascular prostheses are sometimes used to treat aortic aneurysms. Such
15 treatment includes implanting a stent or stent-graft within the diseased vessel to bypass
the anomaly. An aneurysm is a sac formed by the dilation of the wall of the artery.
Aneurysms may be congenital, but are usually caused by disease or, occasionally, by
trauma. Aortic aneurysms which commonly form between the renal arteries and the iliac
arteries are referred to as abdominal aortic aneurysms ("AAAs"). Other aneurysms occur
20 in the aorta, such as thoracic aortic aneurysms ("TAAs") and aortic uni-iliac ("AUI")
aneurysms.

"Endoleak" is the persistent flow of blood into the aneurismal sac after
implantation of an endovascular prosthesis. The management of some types of endoleak
remains controversial, although most can be successfully occluded with surgery, further
25 stent implantation, or embolization. Four types of endoleaks have been defined, based
upon their proposed etiology, as described below.

A type I endoleak, which occurs in up to 10 percent of endovascular aortic
aneurysm repairs, is due to an incompetent seal at either the proximal or distal attachment
sites of the vascular prosthesis, resulting in blood flow at the end of the prosthesis into the

aneurismal sac. Etiologies include undersizing of the diameter of the endograft at the attachment site and ineffective attachment to a vessel wall that is heavily calcified or surrounded by thick thrombus. Type I failures have also been found to be caused by a continual expansion of the aneurysm neck (the portion of the aorta extending cephalad or caudad from the aneurysm, and is not dilated). This expansion rate has been estimated to be about one millimeter per year. Because the aneurysm neck expands beyond the natural resting diameter of the prosthesis, one or more passageways are defined about the prosthesis in communication with the aneurismal sac. Additionally, Type I endoleaks may be caused when circular prostheses are implanted in non-circular aortic lumens, which may be caused by irregular vessel formation and/or calcified topography of the lumen of the aorta.

Type I endoleaks may occur immediately after placement of the prosthesis, or may be delayed. A delayed type I endoleak may be seen during follow-up studies if the prosthesis is deployed into a diseased segment of aorta that dilates over time, leading to a breach in the seal at the attachment site.

Type I endoleaks must be repaired as soon as they are discovered, because the aneurismal sac remains exposed to systemic pressure, predisposing to aneurysmal rupture, and spontaneous closure of the leak is rare. If discovered at the time of initial placement, repair may consist of reversal of anticoagulation and reinflation of the deployment balloon for an extended period of time. These leaks may also be repaired with small extension grafts that are placed over the affected end. These methods are usually sufficient to exclude the aneurysm. Conversion to an open surgical repair may be needed in the rare situation in which the leak is refractory to percutaneous treatment.

Type II endoleaks are the most prevalent type, occurring in 10 to 25 percent of endovascular aortic aneurysm repairs, and are characterized by flow into and out of the aneurismal sac from patent branch vessels. These endoleaks are most often identified on the post procedural CT, in which these leaks appear as collections of contrast outside of the endograft, but within the aneurismal sac. The most frequent sources of type II endoleaks are collateral backflow through patent lumbar arteries and a patent inferior mesenteric artery. Because the sac fills through a collateral network, the endoleak may not be visualized on the arterial phase of CT scanning; delayed imaging is thus required.

Type III and type IV endoleaks are much less common. Type III endoleaks

represent flow into the aneurismal sac from separation between components of a modular system, or tears in the endograft fabric. Type IV endoleaks are due to egress of blood through the pores in the fabric. Type IV leaks heal spontaneously, while type III leaks are repaired with an additional endograft to eliminate systemic flow and pressure in the aneurysm.

As can be readily appreciated, even with the successful implantation of an endovascular prosthesis, failures may occur thereafter. It has been found that type I failures may affect up to 5-10% of all implanted prostheses. Accordingly, there is a clear need for an endovascular prosthesis which can reduce the likelihood of, and ideally eliminate, type I failures.

PCT Publication WO 2008/107885 to Shalev et al., and US Patent Application Publication 2010/0063575 to Shalev et al. in the US national stage thereof, which are incorporated herein by reference, describe a multiple-component expandable endoluminal system for treating a lesion at a bifurcation, including a self expandable tubular root member having a side-looking engagement aperture, and a self expandable tubular trunk member comprising a substantially blood impervious polymeric liner secured therealong. Both have a radially-compressed state adapted for percutaneous intraluminal delivery and a radially-expanded state adapted for endoluminal support.

The following references may be of interest:

US Patent 4,938,740

US Patent 5,824,040 to Cox et al.

US Patent 7,044,962 to Elliott

US Patent Application Publication 2006/0229709 to Morris et al.

US Patent Application Publication 2006/0241740 to Vardi et al.

US Patent Application Publication 2008/0109066 to Quinn

SUMMARY OF APPLICATIONS

In some applications of the present invention, an endovascular stent-graft system is provided for implantation in at least one blood vessel of a patient in a vicinity of an aneurysm. The endovascular stent-graft system comprises an endovascular stent-graft and a heating device, which is coupled to the stent-graft. The heating device is configured to

apply, to a region external to the stent-graft, thermal energy sufficient to coagulate blood flowing into the aneurysm. For some applications, the heating device is activated in response to ascertaining that the patient is at risk of suffering from a type I endoleak, and application of the thermal energy reduces or prevents the type I endoleak. Alternatively, 5 the heating device is activated in response to ascertaining that the patient suffers from a type I endoleak, and application of the thermal energy treats the type I endoleak. Thus the application of the thermal energy may be prophylactic, therapeutic, or both. The thermal energy may be applied exactly one time, periodically, or based on an assessment of the patient's condition.

10 For some applications, the heating device comprises one or more heating elements that are coupled to the stent-graft, such as at least one heating coil, which may be wrapped around a portion of the stent-graft. For some applications, the heating device comprises circuitry and one or more sensors, such as one or more temperature sensors, and/or one or more blood flow sensors. For some applications, the circuitry is configured to monitor at 15 least one temperature and/or at least one parameter of blood flow, and to drive the one or more heating elements to apply the thermal energy responsively to the at least one monitored temperature and/or blood flow parameter.

For some applications, the heating device is configured for wireless control from an extracorporeal location. For some of these applications, the heating device comprises a 20 communication unit, which is configured to communicate with a wireless remote control unit of an extracorporeal control unit. For some applications, the heating device further comprises a power supply. Alternatively or additionally, for some applications, the heating device further comprises a power receiver and storage unit, which is configured to wirelessly receive energy from an extracorporeal energizer.

25 For some applications, the stent-graft system comprises a current application device, rather than the heating device. The current application device typically comprises a plurality of electrodes, and the circuitry is configured to drive the electrodes to apply, to the region external to the stent-graft, an electrical current sufficient to coagulate blood flowing into the aneurysm.

30 There is therefore provided, in accordance with an application of the present invention, apparatus including:

an endovascular stent-graft, configured to be implanted in at least one blood vessel

in a vicinity of an aneurysm; and

a heating device, which is coupled to the stent-graft, and which is configured to apply, to a region external to the stent-graft, thermal energy sufficient to coagulate blood flowing into the aneurysm.

5 For some applications, the heating device is configured to set a level of the thermal energy to be insufficient to cause tissue ablation of an adventitial layer of the aneurysm. For some applications, the heating device is configured to set a level of the thermal energy to increase an average temperature in the region by between 3 and 7 degrees C. For some applications, the heating device is configured to set a level of the thermal energy to increase an average temperature in the region by no more than 6
10 degrees C. For some applications, the heating device is configured to set a level of the thermal energy to increase an average temperature in the region to between a minimum and a maximum temperature, the minimum temperature between 39 and 41 degrees C, and the maximum temperature between 41 and 45 degrees C. For some applications, the stent-graft is shaped so as to define a lumen when in a radially-expanded state, and the heating device is configured to increase an average temperature within the lumen by no
15 more than 2 degrees C.

For some applications, the region surrounds at least 180 degrees of a circumference of the stent-graft, such as 360 degrees of the circumference, and the
20 heating device is configured to apply the thermal energy to the region.

For some applications, the stent-graft is shaped so as to define a lumen when in a radially-expanded state, and the heating device includes one or more heating elements that span at least 300 degrees of a circumference of the lumen, such as 360 degrees of the circumference, at one or more locations selected from the group consisting of: one or
25 more locations outside of the lumen, and one or more locations within the lumen.

For some applications, the stent-graft and the heating device are configured to be entirely implanted in the at least one blood vessel, such that no portion of either of the stent-graft or the heating device extends outside of the at least one blood vessel.

For some applications, the heating device includes one or more heating elements,
30 which include at least one heating coil. For some applications, the heating coil is wrapped around a portion of the stent-graft. For some applications, the heating coil is wrapped around a complete circumference of the stent-graft at least once. For some applications,

the apparatus further includes an extracorporeal control unit, which is configured to wirelessly transmit energy to the heating coil. For some applications, the extracorporeal control unit is configured to inductively drive current through the heating coil to generate the thermal heat.

5 For some applications, the stent-graft is shaped so as to define a lumen when in a radially-expanded state, the heating device includes one or more heating elements having respective surfaces that apply the thermal energy, the heating elements that collectively are positioned along a longitudinal portion of the lumen, and a combined total area of the surfaces is between 1% and 10% of an average cross-sectional area of the lumen along the
10 longitudinal portion.

For some applications, the heating device includes one or more heating elements and circuitry configured to drive the heating elements to apply the thermal energy. For some applications, the circuitry is configured to drive the one or more heating elements to apply the thermal energy such that an average energy consumption rate over all five-
15 second periods of heating does not exceed 5 W.

For some applications, the circuitry is configured to drive the heating elements to apply the thermal energy generally continuously. For some applications, the circuitry is configured to drive the heating elements to apply the thermal energy periodically. For some applications, the circuitry is configured to drive the heating elements to apply the
20 thermal energy intermittently.

For some applications, the heating device is configured to apply the thermal energy such that an average energy consumption rate over all five-second periods of heating does not exceed 5 W.

For some applications, the stent-graft is shaped so as to define a lumen having an
25 axial length when in a radially-expanded state, and the heating device includes one or more heating elements that collectively are positioned along no more than 20% of the axial length.

For some applications, the stent-graft, when in a radially-expanded state, is shaped so as to define a lumen having an upstream end, and the heating device includes one or
30 more heating elements that are coupled to the stent-graft in a vicinity of the upstream end. For some applications, the lumen is a main lumen, and the stent-graft is shaped so as to

define a bifurcated downstream end, which defines first and second generally tubular downstream lumens that are in fluid communication with the main lumen. For some applications, the upstream end is flared.

5 For some applications, the heating device is configured for wireless control from an extracorporeal location. For some applications, the apparatus further includes an extracorporeal control unit, which is configured to wirelessly control the heating device. For some applications, the heating device includes a wireless receiver, and the apparatus further includes an extracorporeal control unit, configured to wirelessly transmit energy to the wireless receiver.

10 For any of the applications described above, the heating device may include at least one sensor, and one or more heating elements. For some applications, the sensor includes a temperature sensor, and the heating device further includes circuitry which is configured to monitor at least one temperature using the temperature sensor, and to drive the one or more heating elements to apply the thermal energy responsively to the at least
15 one monitored temperature. For some applications, the stent-graft is shaped so as to define at least one lumen when in a radially-expanded state, and the at least one temperature is selected from the group consisting of: a temperature of blood flowing within the lumen, and a temperature of blood external to the lumen. For some applications, the circuitry is configured to maintain the temperature of the blood external
20 to the lumen at between a minimum and a maximum temperature, the minimum temperature between 39 and 41 degrees C, and the maximum temperature between 41 and 45 degrees C. For some applications, the circuitry is configured to set at least one heating parameter responsively to the at least one temperature, so as to selectively coagulate the blood flowing into the aneurysm without causing substantial coagulation of the blood
25 flowing within the lumen.

For some applications, the sensor includes a blood flow sensor, and the heating device further includes circuitry which is configured to monitor at least one blood flow parameter using the blood flow sensor, and to drive the one or more heating elements to apply the thermal energy responsively to the at least one monitored blood flow parameter.
30 For some applications, the stent-graft is shaped so as to define at least one lumen when in a radially-expanded state, and the at least one blood flow parameter is selected from the group consisting of: a blood flow parameter of blood flowing within the lumen, and a

blood flow parameter of blood external to the lumen. For some applications, the circuitry is configured to set at least one heating parameter responsively to the at least one monitored blood flow parameter, so as to selectively coagulate the blood flowing into the aneurysm without causing substantial coagulation of the blood flowing within the lumen.

5 For some applications, the stent-graft is shaped so as to define a lumen when in a radially-expanded state, and the at least one sensor is coupled to an external surface of the lumen. Alternatively or additionally, for some applications, the stent-graft is shaped so as to define a lumen when in a radially-expanded state, and the at least one sensor is positioned within the lumen.

10 For some applications, the stent-graft, when in a radially-expanded state, is shaped so as to define a lumen having an upstream end, and the at least one sensor is positioned in a vicinity of the upstream end.

For some applications, the at least one sensor includes a temperature sensor. Alternatively or additionally, for some applications, the at least one sensor includes a
15 blood flow sensor.

For some applications, the at least one sensor includes at least four sensors, distributed around a circumference of the stent-graft.

For any of the applications described above, the stent-graft may include a stent and a graft coupled to the stent, which stent and graft are generally tubular when the stent-
20 graft is in an radially-expanded state. For some applications, the stent includes a plurality of structural stent elements, and the heating device drives an electrical current through a portion of the structural stent elements in order to apply the thermal energy. For some applications, the stent includes a self-expanding elastic material.

For some applications, the graft includes a polymer, which, for example, may be
25 selected from the group consisting of: a fluoropolymer, polytetrafluoroethylene, a polyester, and polyethylene terephthalate.

For some applications, the stent is formed from tubing.

For some applications, the stent includes a superelastic alloy. For some applications, the stent includes a material selected the group consisting of: stainless steel,
30 a cobalt chromium alloy, a platinum/tungsten alloy, and a nickel-titanium alloy.

For some applications, the stent includes a wire stent. For some applications, the

stent includes a ribbon stent.

For any of the applications described above, the stent-graft may be shaped so as to define at least one flared end.

5 For any of the applications described above, the stent-graft and the heating device may be configured to assume respective radially-compressed states for transvascular delivery to the at least one blood vessel, and to transition to respective radially-expanded states upon deployment in the at least one blood vessel. For some applications, the apparatus further includes a delivery catheter, in which the stent-graft and the heating device are initially positioned in their respective radially-compressed states.

10 For any of the applications described above, the heating device may be configured with one or more electrical parameters that are set to coagulate the blood flowing into the aneurysm, the parameters selected from the group consisting of: timing of the application of the thermal energy, and amplitude of the thermal energy.

15 There is further provided, in accordance with an application of the present invention, a method including:

identifying that a patient has an aneurysm; and

20 in response to the identifying, activating an implanted heating device to apply, to a region external to an endovascular stent-graft implanted in at least one blood vessel of the patient, which region is upstream of the aneurysm, thermal energy sufficient to coagulate blood flowing into the aneurysm.

25 For some applications, identifying includes ascertaining that the patient is at risk of suffering from a type I endoleak, and activating includes activating the heating device to apply the thermal energy to coagulate the blood so as to reduce or prevent the type I endoleak. Alternatively or additionally, for some applications, identifying includes ascertaining that the patient suffers from a type I endoleak, and activating includes activating the heating device to apply the thermal energy to coagulate the blood so as to treat the type I endoleak.

There is still further provided, in accordance with an application of the present invention, a method including:

30 implanting, in at least one blood vessel of a patient in a vicinity of an aneurysm, an endovascular stent-graft and a heating device coupled thereto; and

activating the heating device to apply, to a region external to the stent-graft and upstream of the aneurysm, thermal energy sufficient to coagulate blood flowing into the aneurysm.

5 For some applications, activating includes ascertaining that the patient has is at risk of suffering from a type I endoleak, and activating the heating device to apply the thermal energy to coagulate the blood so as to reduce or prevent the type I endoleak. Alternatively or additionally, for some applications, activating includes ascertaining that the patient suffers from a type I endoleak, and activating the heating device to apply the thermal energy to coagulate the blood so as to treat the type I endoleak.

10 For some applications, implanting includes implanting the stent-graft and the heating device in an artery.

For some applications, implanting includes implanting the stent-graft and the heating device entirely within the at least one blood vessel, such that no portion of either of the stent-graft or the heating device extends outside of the at least one blood vessel.

15 For some applications, implanting includes transvascularly introducing the stent-graft and the heating device into the at least one blood vessel. For some applications, transvascularly introducing includes transvascularly introducing the stent-graft and the heating device while the stent-graft and the heating device are positioned in a delivery catheter in respective radially-compressed states, and deploying the stent-graft and the heating device from the delivery catheter in the at least one blood vessel, so that the stent-graft and the heating element assume respective radially-expanded states.

20 For some applications, the stent-graft is shaped so as to define at least one lumen when in a radially-expanded state, and activating includes activating the heating device to apply the thermal energy at a level that selectively coagulates the blood flowing into the aneurysm without causing substantial coagulation of blood flowing within the lumen.

25 For some applications, activating includes activating the heating device to set a level of the thermal energy to be insufficient to cause tissue ablation of an adventitial layer of the aneurysm. For some applications, activating includes activating the heating device to set a level of the thermal energy to increase an average temperature in the region by between 3 and 7 degrees C. For some applications, activating includes activating the heating device to set a level of the thermal energy to increase an average temperature in

the region by no more than 6 degrees C. For some applications, activating includes activating the heating device to set a level of the thermal energy to increase an average temperature in the region to between a minimum and a maximum temperature, the minimum temperature between 39 and 41 degrees C, and the maximum temperature
5 between 41 and 45 degrees C. For some applications, the stent-graft is shaped so as to define a lumen when in a radially-expanded state, and activating includes activating the heating device to increase an average temperature within the lumen by no more than 2 degrees C.

For some applications, activating includes activating the heating device to apply
10 the thermal energy using predetermined electrical parameters.

For some applications, the aneurysm is selected from the group consisting of: an abdominal aortic aneurysm and an iliac artery aneurysm, and activating includes activating the heating device to apply the thermal energy sufficient to coagulate the blood flowing into the selected aneurysm.

For some applications, the stent-graft, when in a radially-expanded state, is shaped
15 so as to define at least one lumen having an upstream end, and activating includes activating the heating device to apply the thermal energy in a vicinity of the upstream end.

For some applications, the heating device is attached to the stent-graft, and activating includes activating the heating device that is attached to the stent-graft. For
20 some applications, the heating device includes one or more heating elements that are attached externally around a portion of the stent-graft, and activating includes activating the heating device to drive the heating elements to apply the thermal energy. For some applications, the heating device includes one or more heating elements that are positioned within the stent-graft, and activating includes activating the heating device to drive the
25 heating elements to apply the thermal energy. For some applications, the heating device is incorporated into the stent-graft, and activating includes activating the heating device that is incorporated into the stent-graft.

For some applications, activating includes activating the heating device to apply the thermal energy generally continuously. For some applications, activating includes
30 activating the heating device to apply the thermal energy periodically. For some applications, activating includes activating the heating device to apply the thermal energy intermittently.

For some applications, activating includes setting one or more electrical parameters of the heating device to coagulate the blood flowing into the aneurysm, the parameters selected from the group consisting of: timing of the application of the thermal energy, and amplitude of the thermal energy.

5 For some applications, activating the heating device includes wirelessly transmitting energy to the heating device from an extracorporeal location. For some applications, activating the heating device includes inductively driving a current through a heating coil of the heating device to generate the thermal heat.

10 For some applications, activating includes activating the heating device to apply the thermal energy such that an average energy consumption rate over all five-second periods of heating does not exceed 5 W.

15 For some applications, activating includes activating the heating device to monitor at least one blood flow parameter, and to apply the thermal energy responsively to the at least one monitored blood flow parameter. For some applications, the stent-graft is shaped so as to define at least one lumen when in a radially-expanded state, and the at least one blood flow parameter is selected from the group consisting of: a blood flow parameter of blood flowing within the lumen, and a blood flow parameter of blood external to the lumen. For some applications, activating includes activating the heating device to set at least one heating parameter responsively to the at least one monitored blood flow parameter, so as to selectively coagulate the blood flowing into the aneurysm without causing substantial coagulation of the blood flowing within the lumen.

25 For some applications, activating includes activating the heating device to monitor at least one temperature, and to apply the thermal energy responsively to the at least one monitored temperature. For some applications, the stent-graft is shaped so as to define at least one lumen when in a radially-expanded state, and the at least one temperature is selected from the group consisting of: a temperature of blood flowing within the lumen, and a temperature of blood external to the lumen. For some applications, activating includes activating the heating device to set at least one heating parameter responsively to the at least one monitored temperature, so as to selectively coagulate the blood flowing into the aneurysm without causing substantial coagulation of the blood flowing within the lumen.

30 For some applications, the method further includes monitoring at least one blood

flow parameter from an extracorporeal location, and activating includes activating the heating device to apply the thermal energy responsively to the at least one monitored blood flow parameter. For some applications, the stent-graft is shaped so as to define at least one lumen when in a radially-expanded state, and the at least one blood flow parameter is selected from the group consisting of: a blood flow parameter of blood flowing within the lumen, and a blood flow parameter of blood external to the lumen. For some applications, activating includes activating the heating device to set at least one heating parameter responsively to the at least one monitored blood flow parameter, so as to selectively coagulate the blood flowing into the aneurysm without causing substantial coagulation of the blood flowing within the lumen. For some applications, monitoring includes performing blood-flow imaging.

There is additionally provided, in accordance with an application of the present invention, apparatus including:

an endovascular stent-graft, configured to be implanted in at least one blood vessel in a vicinity of an aneurysm; and

a current application device, which is coupled to the stent-graft, and which is configured to apply, to a region external to the stent-graft, an electrical current sufficient to coagulate blood flowing into the aneurysm.

For some applications, the current application device is configured to set a level of the electrical current to be insufficient to cause tissue ablation of an adventitial layer of the aneurysm.

For some applications, the current application device is configured to configure the electrical current to heat the blood.

For some applications, the current application device is configured to configure the electrical current to heat the blood by electrophoresis.

For some applications, the region surrounds at least 180 degrees of a circumference of the stent-graft, and the current application device is configured to apply the electrical current to the region.

For some applications, the current application device includes at least one sensor, and one or more electrodes. For some applications, the sensor includes a temperature sensor, and the current application device further includes circuitry which is configured to

monitor at least one temperature using the temperature sensor, and to drive the one or more electrodes to apply the electrical current responsively to the at least one monitored temperature. For some applications, the sensor includes a blood flow sensor, and the current application device further includes circuitry which is configured to monitor at
5 least one blood flow parameter using the blood flow sensor, and to drive the one or more electrodes to apply the electrical current responsively to the at least one monitored blood flow parameter.

There is yet additionally provided, in accordance with an application of the present invention, a method including:

10 identifying that a patient has an aneurysm; and
in response to the identifying, activating an implanted current application device to apply, to a region external to an endovascular stent-graft implanted in at least one blood vessel of the patient, which region is upstream of the aneurysm, an electrical current sufficient to coagulate blood flowing into the aneurysm.

15 For some applications, identifying includes ascertaining that the patient is at risk of suffering from a type I endoleak, and activating includes activating the current application device to apply the thermal energy to coagulate the blood so as to reduce or prevent the type I endoleak. Alternatively or additionally, for some applications, identifying includes ascertaining that the patient suffers from a type I endoleak, and
20 activating includes activating the current application device to apply the thermal energy to coagulate the blood so as to treat the type I endoleak.

There is also provided, in accordance with an application of the present invention, a method including:

25 implanting, in at least one blood vessel of a patient in a vicinity of an aneurysm, an endovascular stent-graft and a current application device coupled thereto; and
activating the current application device to apply, to a region external to the stent-graft upstream of the aneurysm, an electrical current sufficient to coagulate blood flowing into the aneurysm.

30 For some applications, activating includes activating the current application device to set a level of the electrical current to be insufficient to cause tissue ablation of an adventitial layer of the aneurysm.

For some applications, activating includes activating the current application device to configure the electrical current to heat the blood.

For some applications, activating includes activating the current application device to configure the electrical current to heat the blood by electrophoresis.

- 5 For some applications, the aneurysm is selected from the group consisting of: an abdominal aortic aneurysm and an iliac artery aneurysm, and activating includes activating the current application device to apply the electrical current sufficient to coagulate the blood flowing into the selected aneurysm.

10 For some applications, activating includes activating the current application device to monitor at least one blood flow parameter, and to apply the electrical current responsively to the at least one monitored blood flow parameter.

For some applications, activating includes activating the current application device to monitor at least one temperature, and to apply the electrical current responsively to the at least one monitored temperature.

- 15 The present invention will be more fully understood from the following detailed description of embodiments thereof, taken together with the drawings, in which:

BRIEF DESCRIPTION OF THE DRAWINGS

Figs. 1 and 2 are schematic illustrations of an endovascular stent-graft system, in accordance with respective applications of the present invention;

- 20 Fig. 3 is a schematic illustration of a bifurcated configuration of the stent-graft system of Figs. 1 and/or 2, in accordance with an application of the present invention;

Figs. 4 and 5 are schematic block diagrams of the endovascular stent-graft system of Figs. 1, 2, and/or 3, in accordance with respective applications of the present invention;

- 25 Fig. 6 is a schematic illustration of an exemplary deployment of the endovascular stent-graft system of Figs. 1, 2, and/or 3 in an aneurysmatic abdominal aorta, in accordance with an application of the present invention; and

Fig. 7 is a schematic illustration of another configuration of the endovascular stent-graft system of Figs. 1, 2, and/or 3, in accordance with an application of the present invention.

DETAILED DESCRIPTION OF APPLICATIONS

Figs. 1 and 2 are schematic illustrations of an endovascular stent-graft system 10, in accordance with respective applications of the present invention. Endovascular stent-graft system 10 is typically configured to be implanted in at least one blood vessel (such as an artery) in a vicinity of an aneurysm, such as described hereinbelow with reference to Fig. 6. Endovascular stent-graft system 10 comprises an endovascular stent-graft 20 and, for some applications, a heating device 22, which is coupled to stent-graft 20. Heating device 22 is configured to apply, to a region 24 external to stent-graft 20, thermal energy sufficient to coagulate blood flowing into the aneurysm.

Stent-graft 20 typically comprises a stent 30 (which serves as a structural member) and a graft 32, which is shaped as a fluid flow guide. Typically, when stent-graft 20 is in a radially-expanded state, the stent and the graft are generally tubular. Stent 30 typically comprises a plurality of structural stent elements, such as struts. For some applications, at least some of (e.g., all of) the structural stent elements are interconnected, while for other applications, at least a portion of (e.g., all of) the structural stent elements are not interconnected. For some applications, stent 30 comprises a metal, such as stainless steel, a cobalt chromium alloy, a platinum/tungsten alloy, and a nickel-titanium alloy. Alternatively or additionally, the stent comprises a self-expanding elastic material. Alternatively or additionally, the stent comprises a superelastic alloy, such as Nitinol. For some applications, stent 30 comprises a wire stent, while for other applications, stent 30 comprises a ribbon stent. For some applications, stent 30 is formed from tubing.

Graft 32 comprises at least one biologically-compatible substantially fluid-impervious flexible sheet, which is coupled to stent 30, either outside or within the stent, such as by stitching, and covers either an external or an internal surface of at least a portion of the stent. The flexible sheet may comprise, for example, a polymer (e.g., a fluoropolymer, such as polytetrafluoroethylene, or a polyester, such as polyethylene terephthalate (PET)), natural tissue (e.g., saphenous vein or collagen), or a combination thereof.

For some applications, stent-graft 20 is configured to initially be positioned in a delivery catheter in a radially-compressed state, and to assume a radially-expanded state upon being deployed from the delivery catheter. When in the radially-expanded state, stent-graft 20 is shaped so as to define a lumen 34. Figs. 1-3 and 6-7 show the stent-graft

in the radially-expanded state. For some applications, the stent-graft is heat-set to assume the radially-expanded state. Typically, heating device 22 is also configured to assume a radially-compressed state when positioned in the delivery catheter with the stent-graft, and to expand as the stent-graft expands upon being released from the delivery catheter.

5 Typically, region 24 (to which heating device 22 applies the thermal energy) surrounds at least 180 degrees (such as 360 degrees) of a circumference 40 of stent-graft 20. (The at least 180 degrees are not necessarily contiguous, and may include a plurality of distinct circumferential portions.)

10 For some applications, heating device 22 comprises one or more heating elements 42 that are coupled to stent-graft 20, and span at least 300 degrees (such as 360 degrees) of circumference 40 of lumen 34. (The at least 300 degrees are not necessarily contiguous, and may include a plurality of distinct circumferential portions.) Heating elements 42 are positioned either at locations outside lumen 34 (as shown in Fig. 1), such as around the lumen, and/or within the lumen (configuration not shown). For some applications, the one or more heating elements 42 comprise at least one heating coil 44, 15 which may be wrapped around a portion of stent-graft 20. For example, the heating coil may be wrapped around the portion between one and 10 times, and/or the coil may have an axial length along stent-graft 20 of between 0.5 and 4 cm. For some applications, heating coil 44 is exposed to region 24, such as shown in Fig. 1, while for other applications, heating coil 44 is covered by a covering 46, such as shown in Fig. 2 (and 20 Figs. 3, 6, and 7, described hereinbelow).

 Alternatively, for some applications, heating device 22 drives an electrical current through a portion of the structural stent elements (e.g., struts) in order to apply the thermal energy; in other words, the portion of the structural stent elements serves as heating 25 elements 42. Optionally, this portion of the structural stent elements is configured to have a higher resistance than the other structural stent elements; for example, the portion of the structural stent elements may be coated, and/or may comprise a material (e.g., a metal) having a higher resistance than the other structural stent elements.

 When stent-graft 20 is in its radially-expanded state, lumen 34 has an axial length 30 L which, for example, may be at least 3 cm, no more than 30 cm, and/or between 3 and 30 cm. The one or more heating elements 42 collectively are positioned along a longitudinal portion 50 of lumen 34, a length of which portion is typically no more than 50% of axial

length L, such as no more than 30%, no more than 20%, or no more than 10% of axial length L. For some applications, the one or more heating elements 42 are coupled to the stent-graft in a vicinity of an upstream end 52 of lumen 34. For example, all of the heating elements may be positioned within a distance of upstream end 52, measured along
5 an axis of the lumen, which distance is no more than 60% of axial length L, such as no more than 10% of axial length L.

For some applications, the one or more heating elements 42 have respective surfaces that apply the thermal energy. A combined total area of the surfaces may be at least 1%, no more than 10%, and/or between 1% and 10% of an average cross-sectional
10 area of lumen 34 along longitudinal portion 50.

For some applications, heating device 22 comprises one or more sensors 60, such as exactly one sensor, or at least four sensors. One or more of the sensors may be coupled to an external surface of lumen 34, and/or one or more of the sensors may be positioned within the lumen. Typically, the one or more sensors are positioned in a vicinity of
15 upstream end 52 of lumen 34, such as within 1 cm of the upstream end. For some applications in which heating device 22 comprises a plurality of sensors 60, the sensors are distributed around circumference 40 of stent-graft 20, for example as shown in Fig. 2.

For some applications, at least one of sensors 60 comprises a temperature sensor. Alternatively or additionally, for some applications, at least one of sensors 60 comprises a
20 blood flow sensor. For example, the blood flow sensor may comprise one or more ultrasonic transducers, as known in the blood flow measurement art.

For some applications, heating device 22 is incorporated into stent-graft 20 during manufacture of the stent-graft. For other applications, the heating device is attached to the stent-graft after manufacture of the stent-graft, such as by a healthcare worker prior to
25 implantation of the stent-graft, or by a distributor of the stent-graft. For some applications, heating device 22 is provided as a separate unit, and attached to a stent-graft not specially pre-configured for use with the heating device.

Reference is now made to Fig. 3, which is a schematic illustration of a bifurcated configuration of stent-graft system 10, in accordance with an application of the present
30 invention. Other than as described below, this configuration is generally similar to the configurations described hereinabove with reference to Figs. 1 and 2. In this configuration, lumen 34 is a main lumen 54, and stent-graft 20 is shaped so as to define a

bifurcated downstream end 56, which defines first and second generally tubular downstream lumens 58A and 58B that are in fluid communication with main lumen 54. As mentioned above, for some applications, the one or more heating elements 42 may be coupled to stent-graft 20 in a vicinity of upstream end 52 of the main lumen.

5 For some applications, stent-graft 20 is shaped so as to define at least one flared end. For example, upstream end 52 may be flared, as shown in Figs. 3 and 6. For some applications, an upstream-most first portion of the structural stent elements of stent 30 are shaped so as to define a plurality of anchoring elements 60 that extend radially outwardly, and, optionally, upstream, when the stent-graft assumes the radially-expanded state, as
10 shown in Figs. 3 and 6. The anchoring elements anchor the stent-graft to the vascular wall, helping prevent dislodgement. Optionally, one or more of anchoring elements 60 are shaped so as to define respective barbs 62. (As used in the present application, including in the claims, a "barb" means an element having at least one free sharp end, which is sharp enough to enter the aortic wall. The element does not necessarily define a
15 sharp projection extending backward from the sharp end for preventing easy extraction.)

Reference is now made to Figs. 4 and 5, which are schematic block diagrams of endovascular stent-graft system 10, in accordance with respective applications of the present invention. In the configurations shown in both Figs. 4 and 5, heating device 22
20 comprises circuitry 70, which is configured to drive heating elements 42 to apply the thermal energy, as described hereinabove with reference to Figs. 1 and 2. Circuitry 70 may comprise, for example, one or more processors and/or memory, as is known in the art.

For some applications, heating device 22 is configured for wireless control from an extracorporeal location. For some of these applications, such as in the configurations
25 shown in both Figs. 4 and 5, heating device 22 comprises a communication unit 72, which is configured to communicate with a wireless remote control unit 74 of an extracorporeal control unit 76. The wireless remote control unit enables control of heating device 22 from an extracorporeal location, for example as described hereinbelow.

For some applications, as in the configuration shown in Fig. 4, heating device 22
30 further comprises a power supply 77, which may comprise, for example, one or more batteries or capacitors, which are optionally rechargeable. Alternatively or additionally, for some applications, as in the configuration shown in Fig. 5, heating device 22 further

comprises a power receiver and storage unit 78, which is configured to wirelessly receive energy from an extracorporeal energizer 80, either of extracorporeal control unit 76, or of a separate unit. Power receiver and storage unit 78 typically comprises one or more wire coils 82 for wirelessly receiving energy transmitted by extracorporeal energizer 80. For example, the one or more coils may be wrapped around a portion lumen 34, such as shown in Fig. 1.

Further alternatively, for some applications, extracorporeal control unit 76 is configured to wirelessly transmit energy directly to the one or more heating elements 42, such as for applications in which the one or more heating elements comprise the at least one heating coil 44. For example, the extracorporeal control unit may be configured to inductively drive current through the heating coil to generate the thermal heat, or the extracorporeal control unit may be configured to apply an alternating magnetic field to the heating coil, which may comprise a ferromagnetic material. For these applications, power supply 77, power receiver and storage unit 78, and/or circuitry 70 are not necessarily provided. Optionally, a portion of the structural elements of stent 30 serve as the coil, as described hereinabove.

For some applications, circuitry 70 is configured to drive the one or more heating elements 42 to apply the thermal energy by driving a current through the heating elements. For some applications, circuitry 70 is configured to set one or more electrical parameters of the current to coagulate the blood flowing into the aneurysm, the parameters selected from the group consisting of: timing of the application of the thermal energy, and amplitude of the thermal energy.

For some applications, circuitry 70 is configured to drive the one or more heating elements 42 to apply the thermal energy such that an average energy consumption rate over all five-second periods of heating does not exceed 5 W, such as does not exceed 2 W, and/or is at least 0.1 W. For some applications, circuitry 70 is configured to drive the heating elements 42 to apply the thermal energy generally continuously. Alternatively, for some applications, circuitry 70 is configured to drive the heating elements 42 to apply the thermal energy generally periodically, such as a number of minutes per day (e.g., at least one, no more than five, or between one and five minutes per day), or a number of minutes per week. Further alternatively, for some applications, circuitry 70 is configured to drive the heating elements 42 to apply the thermal energy generally intermittently. Still

further alternatively, for some applications, circuitry 70 is configured to drive the heating elements 42 to apply the thermal energy a predetermined number of times, such as exactly once (e.g., soon after implantation). For some applications, heating device 22 is configured to apply the thermal energy using predetermined electrical parameters. For
5 some applications, heating device 22 is configured to apply the thermal energy such that an average energy consumption rate over all five-second periods of heating does not exceed 5 W, such as does not exceed 2 W, and/or is at least 0.1 W.

For some applications, at least one of sensors 60 comprises a temperature sensor, and circuitry 70 is configured to monitor at least one temperature using the temperature
10 sensor, and to drive the one or more heating elements 42 to apply the thermal energy responsively to the at least one monitored temperature. Heating device 22 thus applies the thermal energy in a closed loop, in order to achieve a desired, typically predetermined, temperature, using the monitored temperature as the sensed feedback variable.

For some applications, the temperature sensor is configured (e.g., positioned) to
15 measure the temperature of blood flowing within lumen 34, while for other applications, the temperature sensor is configured (e.g., positioned) to measure the temperature of blood external to lumen 34 (such as in region 24). Alternatively, a plurality of temperature sensors are provided, and one or more are configured to measure the temperature of the blood flowing within the lumen, and one or more are configured to
20 measure the temperature of the blood external to the lumen. For some applications, circuitry 70 is configured to maintain the temperature of the blood external to the lumen at between a minimum temperature (e.g., between 39 and 41 degrees C, such as 39 degrees C) and a maximum temperature (e.g., between 41 and 45 degrees C, such as 44 degrees C). For some applications, circuitry 70 is configured to set at least one heating parameter
25 responsively to the at least one temperature, so as to selectively coagulate the blood flowing into the aneurysm without causing substantial coagulation of the blood flowing within the lumen.

For some applications, at least one of sensors 60 comprises a blood flow sensor, and circuitry 70 is configured to monitor at least one blood flow parameter (e.g., velocity
30 or pressure) using the blood flow sensor, and to drive the one or more heating elements 42 to apply the thermal energy responsively to the at least one monitored blood flow sensor. Heating device 22 thus applies the thermal energy in a closed loop, in order to achieve a

desired, typically predetermined, blood flow parameter (such as velocity or pressure), using the monitored blood flow parameter as the sensed feedback variable.

For some applications, the blood flow sensor is configured (e.g., positioned) to measure the blood flow parameter of blood flowing within lumen 34, while for other applications, the blood flow sensor is configured (e.g., positioned) to measure the blood flow parameter of blood external to lumen 34 (such as in region 24). Alternatively, a plurality of blood flow sensors are provided, and one or more are configured to measure the blood flow parameter of the blood flowing within the lumen, and one or more are configured to measure the blood flow parameter of the blood external to the lumen. For some applications, circuitry 70 is configured to set at least one heating parameter responsively to the at least one blood flow parameter, so as to selectively coagulate the blood flowing into the aneurysm without causing substantial coagulation of the blood flowing within the lumen.

For some applications, heating device 22 is configured to set a level of the thermal energy to increase an average temperature in region 24 by between 3 and 7 degrees C. For some applications, heating device 22 is configured to set a level of the thermal energy to increase an average temperature in region 24 by no more than 6 degrees C. For some applications, heating device 22 is configured to set a level of the thermal energy to increase an average temperature in region 24 to between a minimum temperature (e.g., between 39 and 41 degrees C, such as 39 degrees C) and a maximum temperature (e.g., between 41 and 45 degrees C, such as 44 degrees C). For some applications, heating device 22 is configured to increase an average temperature within lumen 34 by no more than 2 degrees C.

Reference is made to Fig. 6, which is a schematic illustration of an exemplary deployment of endovascular stent-graft system 10 in an aneurysmatic abdominal aorta 100, in accordance with an application of the present invention. Stent-graft 20 is shown in its radially-expanded state, deployed in aneurysmatic abdominal aorta 100 to bypass an abdominal aneurysm 102. The stent-graft extends from a sub-renal neck 103 of the aneurysm to iliac arteries 104, with branching lumens 58A and 58B positioned in respective ones of the iliac arteries. Heating device 22 is configured to apply, to region 24 external to stent-graft 20, thermal energy sufficient to coagulate blood flowing into aneurysm 102. Although system 10 is shown implanted in abdominal aorta 100, this is by

way of example and not limitation; the system may alternatively be deployed in other aneurysmatic blood vessels, such as an aneurysmatic iliac artery.

For some applications, heating device 22 is configured to set a level of the thermal energy to be insufficient to cause tissue ablation, such as tissue ablation of an adventitial layer of aneurysm 102.

Typically, stent-graft 20 and heating device 22 are configured to be entirely implanted in at least one blood vessel, such that no portion of either of the stent-graft or the heating device extends outside of the at least one blood vessel. Typically, implanting the stent-graft and the heating device comprises designating the stent-graft and the heating device to remain implanted in the at least one blood vessel for at least one year.

For some applications, a method for using stent-graft system 10 comprises identifying that a patient has an aneurysm that has been treated with, or is planned to be treated with endovascular stent with, endovascular stent-graft 20, and activating heating device 22 to apply, to region 24 external to stent-graft 20 upstream of the aneurysm, thermal energy sufficient to coagulate blood flowing into the aneurysm. For some applications, a method for using stent-graft system 10 comprises implanting stent-graft 20 and heating device 22 in at least one blood vessel of the patient, and activating the heating device to apply the thermal energy to region 24. Techniques for identifying that a patient has an aneurysm are well known in the art, and are thus not described herein.

For some applications, identifying comprises ascertaining that the patient is at risk of suffering from a type I endoleak, and activating comprises activating heating device 22 to apply the thermal energy to coagulate the blood so as to reduce or prevent the type I endoleak. Alternatively, identifying comprises ascertaining that the patient suffers from a type I endoleak, and activating comprises activating the heating device to apply the thermal energy to coagulate the blood so as to treat the type I endoleak.

For some applications, at least one blood flow parameter is monitored from an extracorporeal location (such as by performing blood-flow imaging), and heating device 22 is activated to apply the thermal energy responsively to the at least one monitored blood flow parameter, such as by sending a control signal from extracorporeal control unit 76. For example, the at least one blood flow parameter may be a blood flow parameter of blood flowing within lumen 34, and/or a blood flow parameter of blood external to the

lumen (such as in region 24). For some applications, heating device 22 may be activated to set at least one heating parameter responsively to the at least one monitored blood flow parameter, so as to selectively coagulate the blood flowing into the aneurysm without causing substantial coagulation of the blood flowing within the lumen.

5 For some applications, stent-graft 20 and heating device 22 are transvascularly introduced into the at least one blood vessel. Typically, the stent-graft and the heating device are transvascularly introduced while the stent-graft and the heating device are positioned in a delivery catheter in respective radially-compressed states. The stent-graft and the heating device are deployed from the delivery catheter in the at least one blood
10 vessel, so that the stent-graft and the heating element assume respective radially-expanded states.

Reference is now made to Fig. 7, which is a schematic illustration of another configuration of endovascular stent-graft system 10, in accordance with an application of the present invention. This configuration of the system is generally similar to the
15 configurations described hereinabove with reference to Figs. 1-6, any may incorporate any of the features of the applications described with reference to these figures, as appropriate, *mutatis mutandis*. However, unlike in the applications described with reference to Figs. 1-6, in the configuration of Fig. 7 stent-graft system 10 comprises a current application device 130, rather than heating device 22. Current application device
20 130 typically comprises a plurality of electrodes 132, and circuitry 70 is configured to drive the electrodes to apply, to region 24 external to the stent-graft, an electrical current sufficient to coagulate blood flowing into the aneurysm. For some applications, current application device 130 is configured to configure the electrical current to heat the blood by electrophoresis. Typically, the current application device is configured to set a level of
25 the electrical current to be insufficient to cause tissue ablation, such as tissue ablation of an adventitial layer of the aneurysm. For example, the current application device may be configured to maintain or achieve the temperatures and/or temperature changes of the blood external to the lumen and/or region 24 described hereinabove with reference to Figs. 4 and 5.. Alternatively, for some applications, system 10 comprises both current
30 application device 130 and heating device 22.

As used in the present application, including in the claims, "tubular" means having the form of an elongated hollow object that defines a conduit therethrough. A "tubular"

structure may have varied cross-sections therealong, and the cross-sections are not necessarily circular. For example, one or more of the cross-sections may be generally elliptical but not circular, or circular. As used in the present application, including in the claims, "suffering" means having a disease or condition.

5 The scope of the present invention includes embodiments described in the following applications, which are assigned to the assignee of the present application and are incorporated herein by reference. In an embodiment, techniques and apparatus described in one or more of the following applications are combined with techniques and apparatus described herein:

- 10 • PCT Application PCT/IL2008/000287, filed March 5, 2008, which published as PCT Publication WO 2008/107885 to Shalev et al., and US Application 12/529,936 in the national stage thereof, which published as US Patent Application Publication 2010/0063575
- US Application 12/529,936, which published as US Patent Application
15 Publication 2010/0063575 to Shalev et al.
- US Provisional Application 60/892,885, filed March 5, 2007
- US Provisional Application 60/991,726, filed December 2, 2007
- US Provisional Application 61/219,758, filed June 23, 2009
- US Provisional Application 61/221,074, filed June 28, 2009
- 20 • PCT Application PCT/IB2010/052861, filed June 23, 2010, which published as PCT Publication WO 2010/150208 to Shalev et al.
- PCT Application PCT/IL2010/000564, filed July 14, 2010, which published as PCT Publication WO 2011/007354 to Benary et al.
- PCT Application PCT/IL2010/000917, filed November 4, 2010
- 25 • PCT Application PCT/IL2010/000999, filed November 30, 2010, entitled, "Multi-component stent-graft system for implantation in a blood vessel with multiple branches"
- PCT Application PCT/IL2010/001018, filed December 2, 2010, entitled, "Endovascular fenestrated stent-grafting"

- PCT Application PCT/IL2010/001037, filed December 8, 2010, entitled, "Endovascular stent-graft system with fenestrated and crossing stent-grafts"
- 5 • PCT Application PCT/IL2010/001087, filed December 27, 2010, entitled, "Endovascular flow direction indicator"

10 It will be appreciated by persons skilled in the art that the present invention is not limited to what has been particularly shown and described hereinabove. Rather, the scope of the present invention includes both combinations and subcombinations of the various features described hereinabove, as well as variations and modifications thereof that are not in the prior art, which would occur to persons skilled in the art upon reading the foregoing description.

CLAIMS

1. Apparatus comprising:
an endovascular stent-graft, configured to be implanted in at least one blood vessel in a vicinity of an aneurysm; and
5 a heating device, which is coupled to the stent-graft, and which is configured to apply, to a region external to the stent-graft, thermal energy sufficient to coagulate blood flowing into the aneurysm.
2. The apparatus according to claim 1, wherein the heating device is configured to set a level of the thermal energy to be insufficient to cause tissue ablation of an adventitial
10 layer of the aneurysm.
3. The apparatus according to claim 1, wherein the heating device is configured to set a level of the thermal energy to increase an average temperature in the region by between 3 and 7 degrees C.
4. The apparatus according to claim 1, wherein the heating device is configured to set
15 a level of the thermal energy to increase an average temperature in the region by no more than 6 degrees C.
5. The apparatus according to claim 1, wherein the heating device is configured to set a level of the thermal energy to increase an average temperature in the region to between a minimum and a maximum temperature, the minimum temperature between 39 and 41
20 degrees C, and the maximum temperature between 41 and 45 degrees C.
6. The apparatus according to claim 1, wherein the stent-graft is shaped so as to define a lumen when in a radially-expanded state, and wherein the heating device is configured to increase an average temperature within the lumen by no more than 2 degrees C.
- 25 7. The apparatus according to claim 1, wherein the region surrounds at least 180 degrees of a circumference of the stent-graft, and wherein the heating device is configured to apply the thermal energy to the region.
8. The apparatus according to claim 7, wherein the region surrounds 360 degrees of the circumference of the stent-graft, and wherein the heating device is configured to apply
30 the thermal energy to the region.

9. The apparatus according to claim 1, wherein the stent-graft is shaped so as to define a lumen when in a radially-expanded state, and wherein the heating device comprises one or more heating elements that span at least 300 degrees of a circumference of the lumen, at one or more locations selected from the group consisting of: one or more
5 locations outside of the lumen, and one or more locations within the lumen.
10. The apparatus according to claim 9, wherein the heating elements span 360 degrees of the circumference of the stent-graft.
11. The apparatus according to claim 1, wherein the stent-graft and the heating device are configured to be entirely implanted in the at least one blood vessel, such that no
10 portion of either of the stent-graft or the heating device extends outside of the at least one blood vessel.
12. The apparatus according to claim 1, wherein the heating device comprises one or more heating elements, which comprise at least one heating coil.
13. The apparatus according to claim 12, wherein the heating coil is wrapped around a
15 portion of the stent-graft.
14. The apparatus according to claim 13, wherein the heating coil is wrapped around a complete circumference of the stent-graft at least once.
15. The apparatus according to claim 12, further comprising an extracorporeal control unit, which is configured to wirelessly transmit energy to the heating coil.
- 20 16. The apparatus according to claim 15, wherein the extracorporeal control unit is configured to inductively drive current through the heating coil to generate the thermal heat.
- 25 17. The apparatus according to claim 1, wherein the stent-graft is shaped so as to define a lumen when in a radially-expanded state, wherein the heating device comprises one or more heating elements having respective surfaces that apply the thermal energy, wherein the heating elements that collectively are positioned along a longitudinal portion of the lumen, and wherein a combined total area of the surfaces is between 1% and 10% of an average cross-sectional area of the lumen along the longitudinal portion.
- 30 18. The apparatus according to claim 1, wherein the heating device comprises one or more heating elements and circuitry configured to drive the heating elements to apply the thermal energy.

19. The apparatus according to claim 18, wherein the circuitry is configured to drive the one or more heating elements to apply the thermal energy such that an average energy consumption rate over all five-second periods of heating does not exceed 5 W.
20. The apparatus according to claim 1, wherein the circuitry is configured to drive the heating elements to apply the thermal energy generally continuously.
21. The apparatus according to claim 1, wherein the circuitry is configured to drive the heating elements to apply the thermal energy periodically.
22. The apparatus according to claim 1, wherein the circuitry is configured to drive the heating elements to apply the thermal energy intermittently.
23. The apparatus according to claim 1, wherein the heating device is configured to apply the thermal energy at a maximum energy consumption rate of between 0.5 and 2 W.
24. The apparatus according to claim 1, wherein the stent-graft is shaped so as to define a lumen having an axial length when in a radially-expanded state, and wherein the heating device comprises one or more heating elements that collectively are positioned along no more than 20% of the axial length.
25. The apparatus according to claim 1, wherein the stent-graft, when in a radially-expanded state, is shaped so as to define a lumen having an upstream end, and wherein the heating device comprises one or more heating elements that are coupled to the stent-graft in a vicinity of the upstream end.
26. The apparatus according to claim 25, wherein the lumen is a main lumen, and wherein the stent-graft is shaped so as to define a bifurcated downstream end, which defines first and second generally tubular downstream lumens that are in fluid communication with the main lumen.
27. The apparatus according to claim 25, wherein the upstream end is flared.
28. The apparatus according to claim 1, wherein the heating device is configured for wireless control from an extracorporeal location.
29. The apparatus according to claim 28, further comprising an extracorporeal control unit, which is configured to wirelessly control the heating device.
30. The apparatus according to claim 28, wherein the heating device comprises a wireless receiver, and wherein the apparatus further comprises an extracorporeal control

unit, configured to wirelessly transmit energy to the wireless receiver.

31. The apparatus according to any one of claims 1-30, wherein the heating device comprises at least one sensor, and one or more heating elements.

5 32. The apparatus according to claim 31, wherein the sensor comprises a temperature sensor, and wherein the heating device further comprises circuitry which is configured to monitor at least one temperature using the temperature sensor, and to drive the one or more heating elements to apply the thermal energy responsively to the at least one monitored temperature.

10 33. The apparatus according to claim 32, wherein the stent-graft is shaped so as to define at least one lumen when in a radially-expanded state, and wherein the at least one temperature is selected from the group consisting of: a temperature of blood flowing within the lumen, and a temperature of blood external to the lumen.

15 34. The apparatus according to claim 33, wherein the circuitry is configured to maintain the temperature of the blood external to the lumen at between a minimum and a maximum temperature, the minimum temperature between 39 and 41 degrees C, and the maximum temperature between 41 and 45 degrees C.

20 35. The apparatus according to claim 33, wherein the circuitry is configured to set at least one heating parameter responsively to the at least one temperature, so as to selectively coagulate the blood flowing into the aneurysm without causing substantial coagulation of the blood flowing within the lumen.

25 36. The apparatus according to claim 31, wherein the sensor comprises a blood flow sensor, and wherein the heating device further comprises circuitry which is configured to monitor at least one blood flow parameter using the blood flow sensor, and to drive the one or more heating elements to apply the thermal energy responsively to the at least one monitored blood flow parameter.

30 37. The apparatus according to claim 36, wherein the stent-graft is shaped so as to define at least one lumen when in a radially-expanded state, and wherein the at least one blood flow parameter is selected from the group consisting of: a blood flow parameter of blood flowing within the lumen, and a blood flow parameter of blood external to the lumen.

38. The apparatus according to claim 37, wherein the circuitry is configured to set at

least one heating parameter responsively to the at least one monitored blood flow parameter, so as to selectively coagulate the blood flowing into the aneurysm without causing substantial coagulation of the blood flowing within the lumen.

39. The apparatus according to claim 31, wherein the stent-graft is shaped so as to
5 define a lumen when in a radially-expanded state, and wherein the at least one sensor is coupled to an external surface of the lumen.
40. The apparatus according to claim 31, wherein the stent-graft is shaped so as to define a lumen when in a radially-expanded state, and wherein the at least one sensor is positioned within the lumen.
- 10 41. The apparatus according to claim 31, wherein the stent-graft, when in a radially-expanded state, is shaped so as to define a lumen having an upstream end, and wherein the at least one sensor is positioned in a vicinity of the upstream end.
42. The apparatus according to claim 31, wherein the at least one sensor comprises a temperature sensor.
- 15 43. The apparatus according to claim 31, wherein the at least one sensor comprises a blood flow sensor.
44. The apparatus according to claim 31, wherein the at least one sensor comprises at least four sensors, distributed around a circumference of the stent-graft.
45. The apparatus according to any one of claims 1-30, wherein the stent-graft
20 comprises a stent and a graft coupled to the stent, which stent and graft are generally tubular when the stent-graft is in an radially-expanded state.
46. The apparatus according to claim 45, wherein the stent comprises a plurality of structural stent elements, and wherein the heating device drives an electrical current through a portion of the structural stent elements in order to apply the thermal energy.
- 25 47. The apparatus according to claim 45, wherein the stent comprises a self-expanding elastic material.
48. The apparatus according to claim 45, wherein the graft comprises a polymer.
49. The apparatus according to claim 48, wherein the polymer is selected from the group consisting of: a fluoropolymer, polytetrafluoroethylene, a polyester, and
30 polyethylene therephthalate.

50. The apparatus according to claim 45, wherein the stent is formed from tubing.
51. The apparatus according to claim 45, wherein the stent comprises a superelastic alloy.
52. The apparatus according to claim 45, wherein the stent comprises a material
5 selected the group consisting of: stainless steel, a cobalt chromium alloy, a
platinum/tungsten alloy, and a nickel-titanium alloy.
53. The apparatus according to claim 45, wherein the stent comprises a wire stent.
54. The apparatus according to claim 45, wherein the stent comprises a ribbon stent.
55. The apparatus according to any one of claims 1-30, wherein the stent-graft is
10 shaped so as to define at least one flared end.
56. The apparatus according to any one of claims 1-30, wherein the stent-graft and the
heating device are configured to assume respective radially-compressed states for
transvascular delivery to the at least one blood vessel, and to transition to respective
radially-expanded states upon deployment in the at least one blood vessel.
- 15 57. The apparatus according to claim 56, further comprising a delivery catheter, in
which the stent-graft and the heating device are initially positioned in their respective
radially-compressed states.
58. The apparatus according to any one of claims 1-30, wherein the heating device is
configured with one or more electrical parameters that are set to coagulate the blood
20 flowing into the aneurysm, the parameters selected from the group consisting of: timing of
the application of the thermal energy, and amplitude of the thermal energy.
59. A method comprising:
identifying that a patient has an aneurysm; and
in response to the identifying, activating an implanted heating device to apply, to a
25 region external to an endovascular stent-graft implanted in at least one blood vessel of the
patient, which region is upstream of the aneurysm, thermal energy sufficient to coagulate
blood flowing into the aneurysm.
60. The method according to claim 59, wherein identifying comprises ascertaining
that the patient is at risk of suffering from a type I endoleak, and wherein activating
30 comprises activating the heating device to apply the thermal energy to coagulate the blood

so as to reduce or prevent the type I endoleak.

61. The method according to claim 59, wherein identifying comprises ascertaining that the patient suffers from a type I endoleak, and wherein activating comprises activating the heating device to apply the thermal energy to coagulate the blood so as to
5 treat the type I endoleak.

62. A method comprising:
implanting, in at least one blood vessel of a patient in a vicinity of an aneurysm, an endovascular stent-graft and a heating device coupled thereto; and
activating the heating device to apply, to a region external to the stent-graft and
10 upstream of the aneurysm, thermal energy sufficient to coagulate blood flowing into the aneurysm.

63. The method according to claim 62, wherein activating comprises:
ascertaining that the patient has is at risk of suffering from a type I endoleak; and
activating the heating device to apply the thermal energy to coagulate the blood so
15 as to reduce or prevent the type I endoleak.

64. The method according to claim 62, wherein activating comprises:
ascertaining that the patient suffers from a type I endoleak; and
activating the heating device to apply the thermal energy to coagulate the blood so
as to treat the type I endoleak.

20 65. The method according to claim 62, wherein implanting comprises implanting the stent-graft and the heating device in an artery.

66. The method according to claim 62, wherein implanting comprises implanting the stent-graft and the heating device entirely within the at least one blood vessel, such that no portion of either of the stent-graft or the heating device extends outside of the at least one
25 blood vessel.

67. The method according to claim 62, wherein implanting comprises transvascularly introducing the stent-graft and the heating device into the at least one blood vessel.

68. The method according to claim 67, wherein transvascularly introducing comprises:
transvascularly introducing the stent-graft and the heating device while the stent-
30 graft and the heating device are positioned in a delivery catheter in respective radially-compressed states; and

deploying the stent-graft and the heating device from the delivery catheter in the at least one blood vessel, so that the stent-graft and the heating element assume respective radially-expanded states.

- 5 69. The method according to any one of claims 59 and 62, wherein the stent-graft is shaped so as to define at least one lumen when in a radially-expanded state, and wherein activating comprises activating the heating device to apply the thermal energy at a level that selectively coagulates the blood flowing into the aneurysm without causing substantial coagulation of blood flowing within the lumen.
- 10 70. The method according to any one of claims 59 and 62, wherein activating comprises activating the heating device to set a level of the thermal energy to be insufficient to cause tissue ablation of an adventitial layer of the aneurysm.
71. The method according to any one of claims 59 and 62, wherein activating comprises activating the heating device to set a level of the thermal energy to increase an average temperature in the region by between 3 and 7 degrees C.
- 15 72. The method according to any one of claims 59 and 62, wherein activating comprises activating the heating device to set a level of the thermal energy to increase an average temperature in the region by no more than 6 degrees C.
- 20 73. The method according to any one of claims 59 and 62, wherein activating comprises activating the heating device to set a level of the thermal energy to increase an average temperature in the region to between a minimum and a maximum temperature, the minimum temperature between 39 and 41 degrees C, and the maximum temperature between 41 and 45 degrees C.
- 25 74. The method according to any one of claims 59 and 62, wherein the stent-graft is shaped so as to define a lumen when in a radially-expanded state, and wherein activating comprises activating the heating device to increase an average temperature within the lumen by no more than 2 degrees C.
75. The method according to any one of claims 59 and 62, wherein activating comprises activating the heating device to apply the thermal energy using predetermined electrical parameters.
- 30 76. The method according to any one of claims 59 and 62, wherein the aneurysm is selected from the group consisting of: an abdominal aortic aneurysm and an iliac artery

aneurysm, and wherein activating comprises activating the heating device to apply the thermal energy sufficient to coagulate the blood flowing into the selected aneurysm.

77. The method according to any one of claims 59 and 62, wherein the stent-graft, when in a radially-expanded state, is shaped so as to define at least one lumen having an upstream end, and wherein activating comprises activating the heating device to apply the thermal energy in a vicinity of the upstream end.

78. The method according to any one of claims 59 and 62, wherein the heating device is attached to the stent-graft, and wherein activating comprises activating the heating device that is attached to the stent-graft.

79. The method according to claim 78, wherein the heating device includes one or more heating elements that are attached externally around a portion of the stent-graft, and wherein activating comprises activating the heating device to drive the heating elements to apply the thermal energy.

80. The method according to claim 78, wherein the heating device includes one or more heating elements that are positioned within the stent-graft, and wherein activating comprises activating the heating device to drive the heating elements to apply the thermal energy.

81. The method according to claim 78, wherein the heating device is incorporated into the stent-graft, and wherein activating comprises activating the heating device that is incorporated into the stent-graft.

82. The method according to any one of claims 59 and 62, wherein activating comprises activating the heating device to apply the thermal energy generally continuously.

83. The method according to any one of claims 59 and 62, wherein activating comprises activating the heating device to apply the thermal energy periodically.

84. The method according to any one of claims 59 and 62, wherein activating comprises activating the heating device to apply the thermal energy intermittently.

85. The method according to any one of claims 59 and 62, wherein activating comprises setting one or more electrical parameters of the heating device to coagulate the blood flowing into the aneurysm, the parameters selected from the group consisting of: timing of the application of the thermal energy, and amplitude of the thermal energy.

86. The method according to any one of claims 59 and 62, wherein activating the heating device comprises wirelessly transmitting energy to the heating device from an extracorporeal location.
87. The method according to claim 86, wherein activating the heating device
5 comprises inductively driving a current through a heating coil of the heating device to generate the thermal heat.
88. The method according to any one of claims 59 and 62, wherein activating comprises activating the heating device to apply the thermal energy such that an average energy consumption rate over all five-second periods of heating does not exceed 5 W.
- 10 89. The method according to any one of claims 59 and 62, wherein activating comprises activating the heating device to monitor at least one blood flow parameter, and to apply the thermal energy responsively to the at least one monitored blood flow parameter.
90. The method according to claim 89, wherein the stent-graft is shaped so as to
15 define at least one lumen when in a radially-expanded state, and wherein the at least one blood flow parameter is selected from the group consisting of: a blood flow parameter of blood flowing within the lumen, and a blood flow parameter of blood external to the lumen.
91. The method according to claim 90, wherein activating comprises activating the
20 heating device to set at least one heating parameter responsively to the at least one monitored blood flow parameter, so as to selectively coagulate the blood flowing into the aneurysm without causing substantial coagulation of the blood flowing within the lumen.
92. The method according to any one of claims 59 and 62, wherein activating
25 comprises activating the heating device to monitor at least one temperature, and to apply the thermal energy responsively to the at least one monitored temperature.
93. The method according to claim 92, wherein the stent-graft is shaped so as to define at least one lumen when in a radially-expanded state, and wherein the at least one temperature is selected from the group consisting of: a temperature of blood flowing within the lumen, and a temperature of blood external to the lumen.
- 30 94. The method according to claim 93, wherein activating comprises activating the heating device to set at least one heating parameter responsively to the at least one

monitored temperature, so as to selectively coagulate the blood flowing into the aneurysm without causing substantial coagulation of the blood flowing within the lumen.

95. The method according to any one of claims 59 and 62, wherein the method further comprises monitoring at least one blood flow parameter from an extracorporeal location, and wherein activating comprises activating the heating device to apply the thermal energy responsively to the at least one monitored blood flow parameter.

96. The method according to claim 95, wherein the stent-graft is shaped so as to define at least one lumen when in a radially-expanded state, and wherein the at least one blood flow parameter is selected from the group consisting of: a blood flow parameter of blood flowing within the lumen, and a blood flow parameter of blood external to the lumen.

97. The method according to claim 96, wherein activating comprises activating the heating device to set at least one heating parameter responsively to the at least one monitored blood flow parameter, so as to selectively coagulate the blood flowing into the aneurysm without causing substantial coagulation of the blood flowing within the lumen.

98. The method according to claim 95, wherein monitoring comprises performing blood-flow imaging.

99. Apparatus comprising:
an endovascular stent-graft, configured to be implanted in at least one blood vessel in a vicinity of an aneurysm; and
a current application device, which is coupled to the stent-graft, and which is configured to apply, to a region external to the stent-graft, an electrical current sufficient to coagulate blood flowing into the aneurysm.

100. The apparatus according to claim 99, wherein the current application device is configured to set a level of the electrical current to be insufficient to cause tissue ablation of an adventitial layer of the aneurysm.

101. The apparatus according to claim 99, wherein the current application device is configured to configure the electrical current to heat the blood.

102. The apparatus according to claim 101, wherein the current application device is configured to configure the electrical current to heat the blood by electrophoresis.

103. The apparatus according to claim 99, wherein the region surrounds at least 180 degrees of a circumference of the stent-graft, and wherein the current application device is configured to apply the electrical current to the region.
104. The apparatus according to claim 99, wherein the current application device
5 comprises at least one sensor, and one or more electrodes.
105. The apparatus according to claim 104, wherein the sensor comprises a temperature sensor, and wherein the current application device further comprises circuitry which is configured to monitor at least one temperature using the temperature sensor, and to drive the one or more electrodes to apply the electrical current responsively to the at least one
10 monitored temperature.
106. The apparatus according to claim 104, wherein the sensor comprises a blood flow sensor, and wherein the current application device further comprises circuitry which is configured to monitor at least one blood flow parameter using the blood flow sensor, and to drive the one or more electrodes to apply the electrical current responsively to the at
15 least one monitored blood flow parameter.
107. A method comprising:
identifying that a patient has an aneurysm; and
activating an implanted current application device to apply, to a region external to an endovascular stent-graft implanted in at least one blood vessel of the patient, which
20 region is upstream of the aneurysm, an electrical current sufficient to coagulate blood flowing into the aneurysm.
108. The method according to claim 107, wherein identifying comprises ascertaining that the patient is at risk of suffering from a type I endoleak, and wherein activating comprises activating the current application device to apply the thermal energy to
25 coagulate the blood so as to reduce or prevent the type I endoleak.
109. The method according to claim 107, wherein identifying comprises ascertaining that the patient suffers from a type I endoleak, and wherein activating comprises activating the current application device to apply the thermal energy to coagulate the blood so as to treat the type I endoleak.
- 30 110. A method comprising:
implanting, in at least one blood vessel of a patient in a vicinity of an aneurysm, an

endovascular stent-graft and a current application device coupled thereto; and

activating the current application device to apply, to a region external to the stent-graft upstream of the aneurysm, an electrical current sufficient to coagulate blood flowing into the aneurysm.

5 111. The method according to any one of claims 107 and 110, wherein activating comprises activating the current application device to set a level of the electrical current to be insufficient to cause tissue ablation of an adventitial layer of the aneurysm.

112. The method according to any one of claims 107 and 110, wherein activating comprises activating the current application device to configure the electrical current to
10 heat the blood.

113. The method according to claim 112, wherein activating comprises activating the current application device to configure the electrical current to heat the blood by electrophoresis.

114. The method according to any one of claims 107 and 110, wherein the aneurysm is
15 selected from the group consisting of: an abdominal aortic aneurysm and an iliac artery aneurysm, and wherein activating comprises activating the current application device to apply the electrical current sufficient to coagulate the blood flowing into the selected aneurysm.

115. The method according to any one of claims 107 and 110, wherein activating
20 comprises activating the current application device to monitor at least one blood flow parameter, and to apply the electrical current responsively to the at least one monitored blood flow parameter.

116. The method according to any one of claims 107 and 110, wherein activating
25 comprises activating the current application device to monitor at least one temperature, and to apply the electrical current responsively to the at least one monitored temperature.

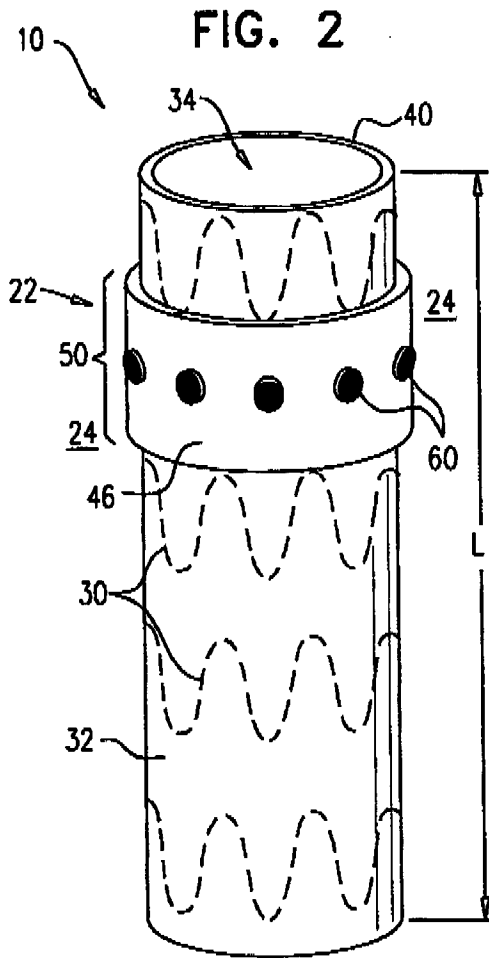
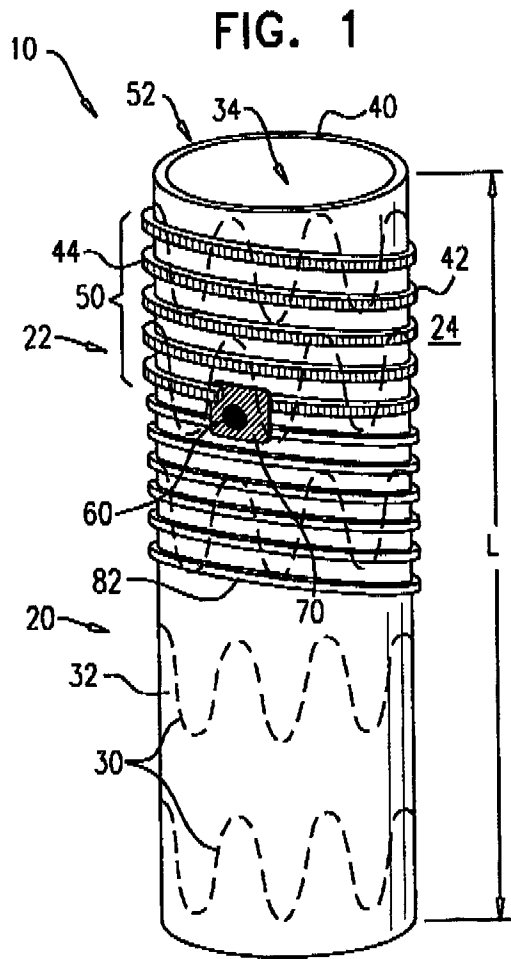

FIG. 3

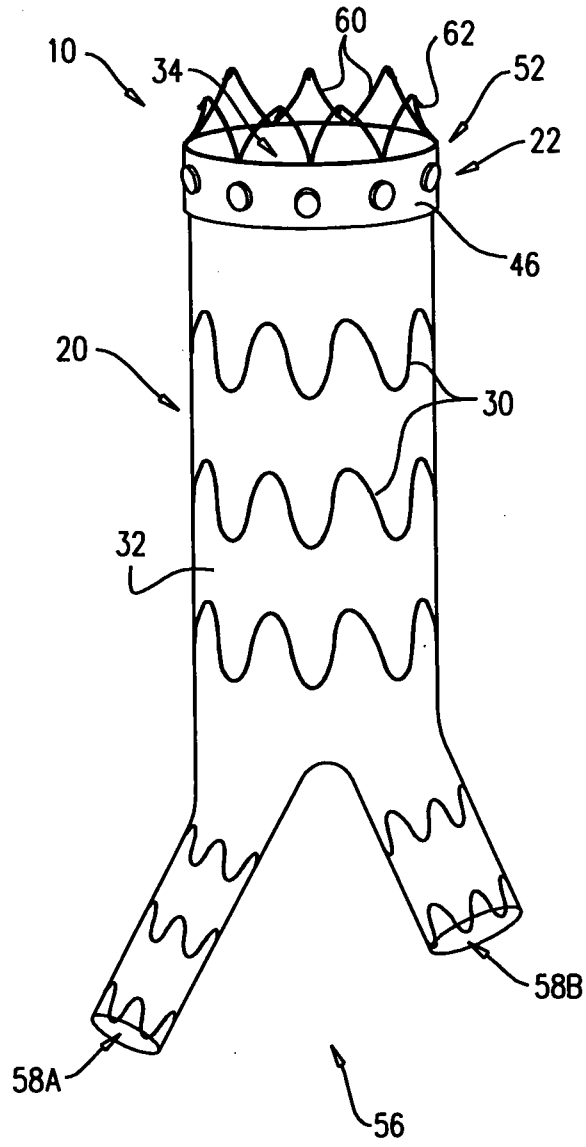

FIG. 4

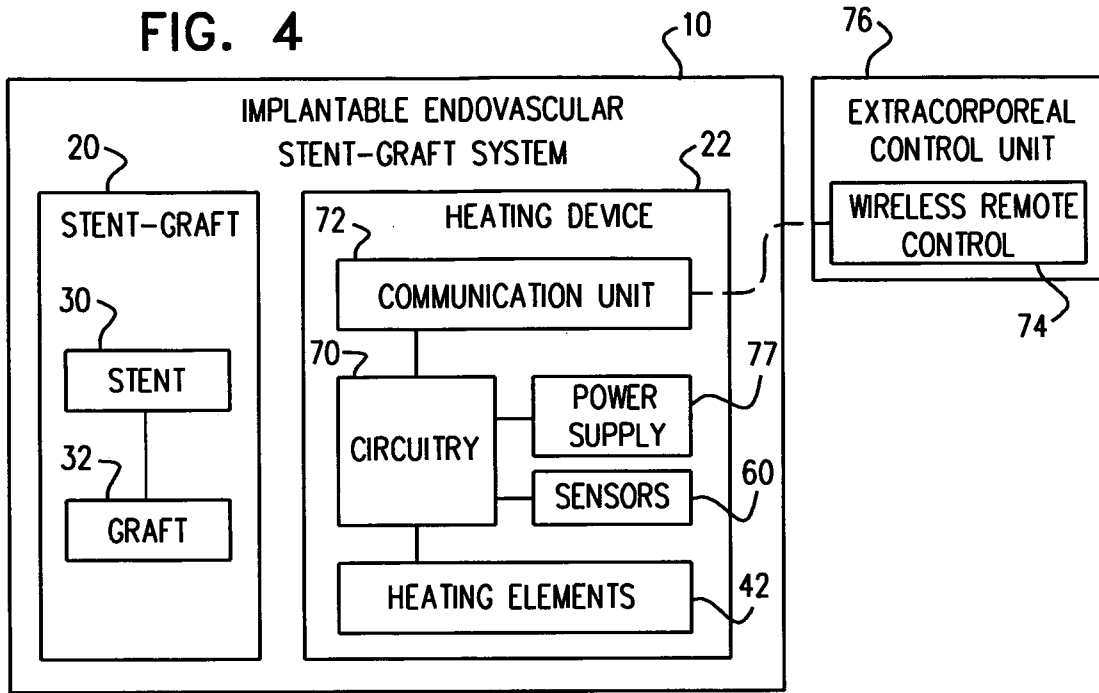

FIG. 5

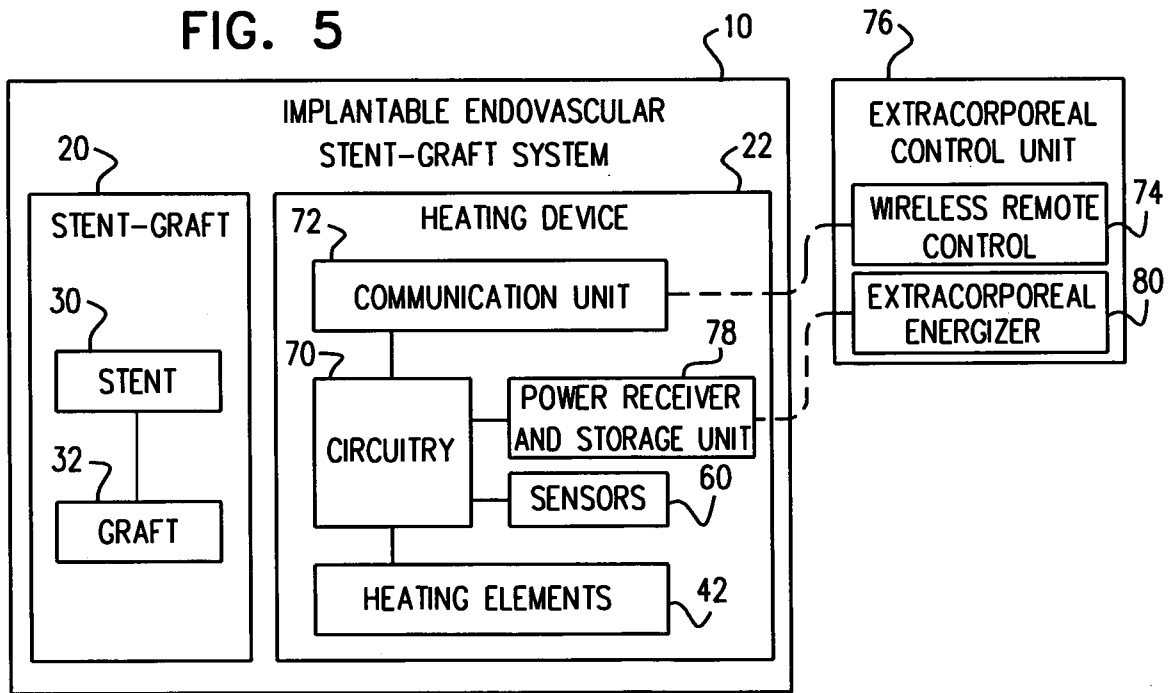

FIG. 6

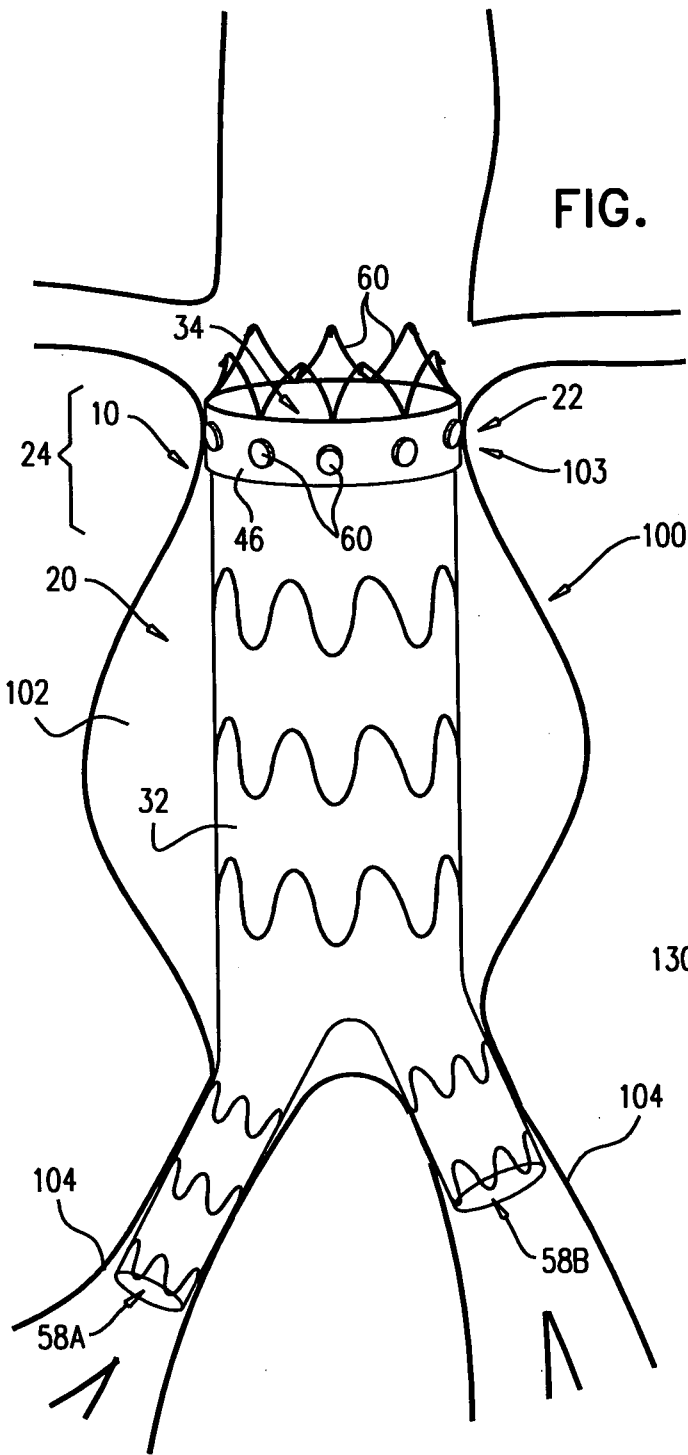
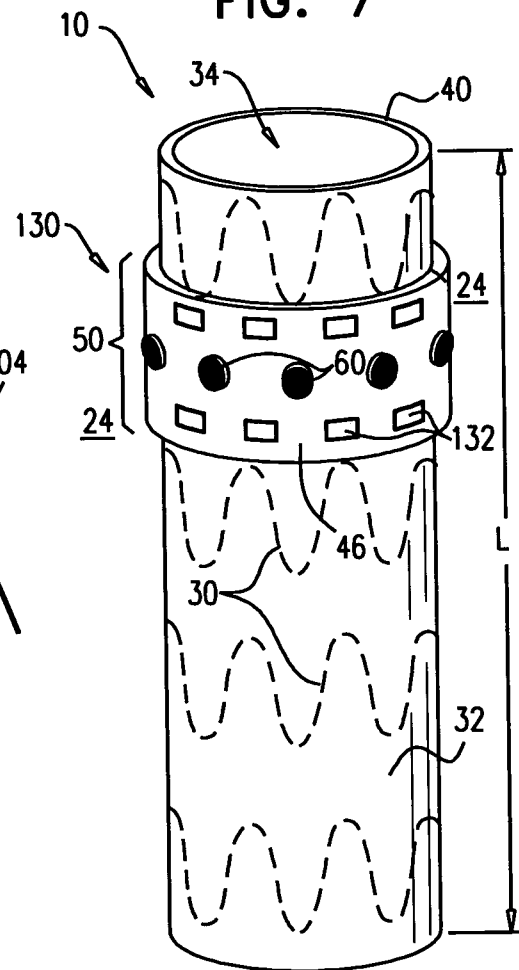

FIG. 7



INTERNATIONAL SEARCH REPORT

International application No.

PCT/IL 11/00135

A. CLASSIFICATION OF SUBJECT MATTER

IPC(8) - A61F 2/06 (2011.01)

USPC - 623/1.13

According to International Patent Classification (IPC) or to both national classification and IPC

B. FIELDS SEARCHED

Minimum documentation searched (classification system followed by classification symbols)

USPC: 623/1.13

Documentation searched other than minimum documentation to the extent that such documents are included in the fields searched

USPC: 606/1, 27, 32, 34, 40, 41, 49; 607/1, 2, 61, 62, 65, 96, 98, 99, 113, 115, 116; 623/1.1, 1.11, 1.15, 1.18, 1.19, 1.2, 1.3, 1.31, 1.35, 1.44, 66.1 (keyword limited; terms below)

Electronic data base consulted during the international search (name of data base and, where practicable, search terms used)

PubWEST(PGPB, USPT, EPAB, JPAB); Google

Search Terms Used: coagulat\$3, thrombosis, anastomosis, coil, heat\$3, thermal, blood, tissue, vessel, stent, graft, blood flow imag\$3, tub\$3, ribbon, endoleak, electrophoresis, aneurysm

C. DOCUMENTS CONSIDERED TO BE RELEVANT

Category*	Citation of document, with indication, where appropriate, of the relevant passages	Relevant to claim No.
Y	US 2007/0112344 A1 (KEILMAN) 17 May 2007 (17.05.2007) fig 7, 26, para [0022], [0103], [0124]-[0125], [0143]-[0144], [0154]-[0155], [0184]-[0185], [0188]	1-116
Y	US 2005/0065545 A1 (WALLACE) 24 March 2005 (24.03.2005) para [0006]-[0007], [0034]-[0035]	1-116
Y	US 2003/0236567 A1 (ELLIOT) 25 December 2003 (25.12.2003) fig 7, para [0009], [0040]	27, 31/(27)-54/(27), 55, 56/(27)-58/(27), 60-61, 63-64, 108-109
Y	US 2007/0060989 A1 (DEEM et al) 15 March 2007 (15.03.2007) para [0061]	102, 113
Y	US 2007/0255388 A1 (RUDAKOV et al) 01 November 2007 (01.11.2007) para [0126], [0132]	50, 54

 Further documents are listed in the continuation of Box C.

* Special categories of cited documents:

"A" document defining the general state of the art which is not considered to be of particular relevance

"E" earlier application or patent but published on or after the international filing date

"L" document which may throw doubts on priority claim(s) or which is cited to establish the publication date of another citation or other special reason (as specified)

"O" document referring to an oral disclosure, use, exhibition or other means

"P" document published prior to the international filing date but later than the priority date claimed

"T" later document published after the international filing date or priority date and not in conflict with the application but cited to understand the principle or theory underlying the invention

"X" document of particular relevance; the claimed invention cannot be considered novel or cannot be considered to involve an inventive step when the document is taken alone

"Y" document of particular relevance; the claimed invention cannot be considered to involve an inventive step when the document is combined with one or more other such documents, such combination being obvious to a person skilled in the art

"&" document member of the same patent family

Date of the actual completion of the international search

08 June 2011 (08.06.2011)

Date of mailing of the international search report

28 JUN 2011

Name and mailing address of the ISA/US

Mail Stop PCT, Attn: ISA/US, Commissioner for Patents
P.O. Box 1450, Alexandria, Virginia 22313-1450

Facsimile No. 571-273-3201

Authorized officer:

Lee W. Young

PCT Helpdesk: 571-272-4300
PCT OSP: 571-272-7774