



US012191747B1

(12) **United States Patent**
Krasnoff

(10) **Patent No.:** **US 12,191,747 B1**
(45) **Date of Patent:** ***Jan. 7, 2025**

(54) **CENTRIPETAL MAGNET ACCELERATOR UTILIZING MAGNETS TO PRODUCE ROTATIONAL MOTION FOR GENERATING ELECTRICITY**

(71) Applicant: **DUPLICENT, LLC**, Santa Monica, CA (US)

(72) Inventor: **Curren Emmett Krasnoff**, Sanata Monica, CA (US)

(73) Assignee: **Duplicent, LLC**, Santa Monica, CA (US)

(*) Notice: Subject to any disclaimer, the term of this patent is extended or adjusted under 35 U.S.C. 154(b) by 0 days.

This patent is subject to a terminal disclaimer.

(21) Appl. No.: **18/320,549**

(22) Filed: **May 19, 2023**

Related U.S. Application Data

(63) Continuation of application No. 17/891,040, filed on Aug. 18, 2022, now Pat. No. 11,682,960, which is a continuation of application No. 17/465,389, filed on Sep. 2, 2021, now Pat. No. 11,451,125, which is a continuation of application No. PCT/US2021/026021, filed on Apr. 6, 2021.

(60) Provisional application No. 63/146,619, filed on Feb. 6, 2021, provisional application No. 63/005,538, filed on Apr. 6, 2020.

(51) **Int. Cl.**
H02K 53/00 (2006.01)
H02K 7/02 (2006.01)
H02K 7/116 (2006.01)
H02K 5/00 (2006.01)
H02K 5/16 (2006.01)

H02K 35/02 (2006.01)
H02K 99/00 (2014.01)
(52) **U.S. Cl.**
CPC **H02K 53/00** (2013.01); **H02K 7/02** (2013.01); **H02K 7/116** (2013.01); **H02K 5/00** (2013.01); **H02K 5/16** (2013.01); **H02K 35/02** (2013.01); **H02K 99/00** (2016.11)
(58) **Field of Classification Search**
CPC .. **H02K 5/00**; **H02K 5/16**; **H02K 7/00**; **H02K 7/02**; **H02K 7/116**; **H02K 35/02**; **H02K 53/00**; **H02K 99/00**; **H02K 2201/00**
USPC 310/74
See application file for complete search history.

(56) **References Cited**

U.S. PATENT DOCUMENTS

8,810,050 B1 * 8/2014 Reiner H02K 53/00 290/1 A
10,605,230 B1 * 3/2020 Lahtinen F03D 80/82
11,148,784 B2 * 10/2021 Romeu B64C 11/06
11,451,125 B2 * 9/2022 Krasnoff H02K 7/02
2002/0167235 A1 * 11/2002 Long H02K 49/10 310/80

(Continued)

Primary Examiner — Rashad H Johnson
(74) *Attorney, Agent, or Firm* — GREENBERG TRAURIG, LLP

(57) **ABSTRACT**

An assembly for generating electricity includes a circular track configured to rotate about a first axis of rotation, the circular track comprising a first magnet having a face that is at an angle with respect to the first axis of rotation, a second magnet positioned at a center of the circular track, wherein a face of the second magnet is an opposite polarity to the face of the first magnet such that the second magnet repels the first magnet to rotate the circular track, and a device for converting rotational motion from the circular track into electricity.

20 Claims, 5 Drawing Sheets

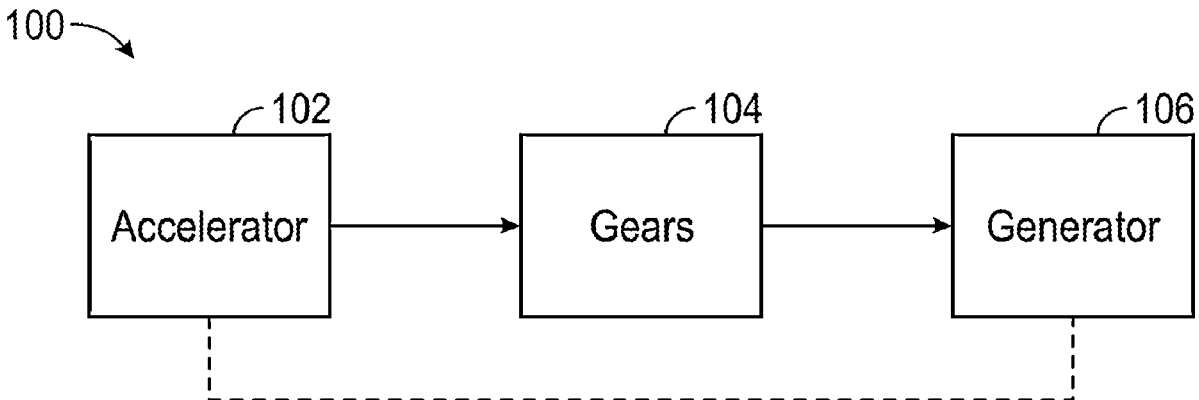

(56)

References Cited

U.S. PATENT DOCUMENTS

2004/0232792	A1*	11/2004	Erfourth	H02K 21/22 310/156.38
2006/0038456	A1*	2/2006	Bojiuc	H02K 23/54 310/156.32
2012/0299408	A1	11/2012	Higuchi	
2013/0175890	A1*	7/2013	Atwood	H02K 53/00 310/46
2013/0257189	A1*	10/2013	Blum	G01M 1/36 29/598
2014/0042840	A1*	2/2014	Chamberlin	H02K 15/03 29/598
2014/0070654	A1*	3/2014	Hamer	H02K 9/223 310/156.21
2014/0252902	A1*	9/2014	Binkowski	H02K 31/02 310/156.08
2015/0115756	A1*	4/2015	Walsh	F16C 32/0408 310/90.5
2015/0188400	A1*	7/2015	Kemp	H02K 53/00 74/DIG. 9
2015/0303763	A1*	10/2015	Takimoto	H02K 5/10 310/85
2016/0099570	A1*	4/2016	The'	H02J 7/35 307/72
2017/0163103	A1*	6/2017	Amer	H02K 1/17
2018/0226874	A1*	8/2018	Ho	H02K 49/102
2018/0248459	A1*	8/2018	Al-Jobory	H02K 35/02
2018/0323694	A1*	11/2018	Suk	H02K 99/10
2020/0408192	A1*	12/2020	Ando	F03D 3/005
2021/0143723	A1*	5/2021	De Gasperis	H02K 53/00
2021/0281131	A1*	9/2021	McKee, Jr.	H02K 1/17

* cited by examiner

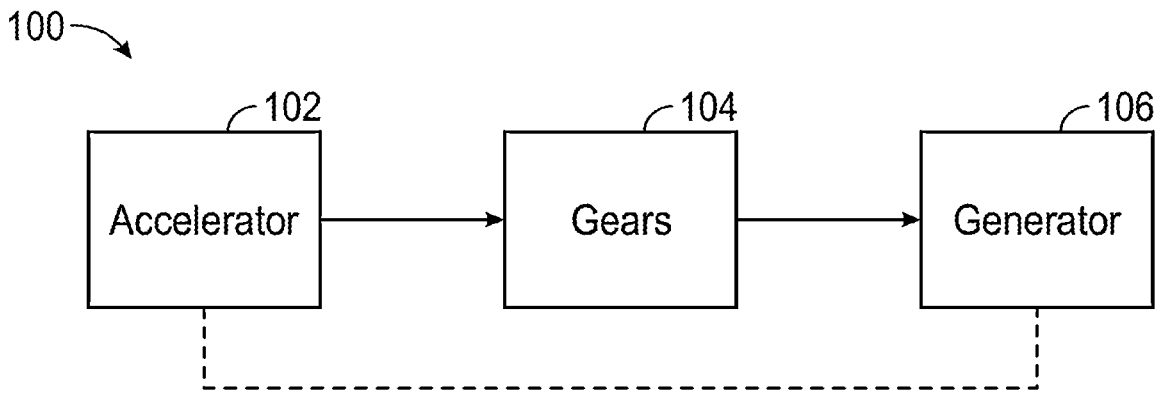

FIG. 1

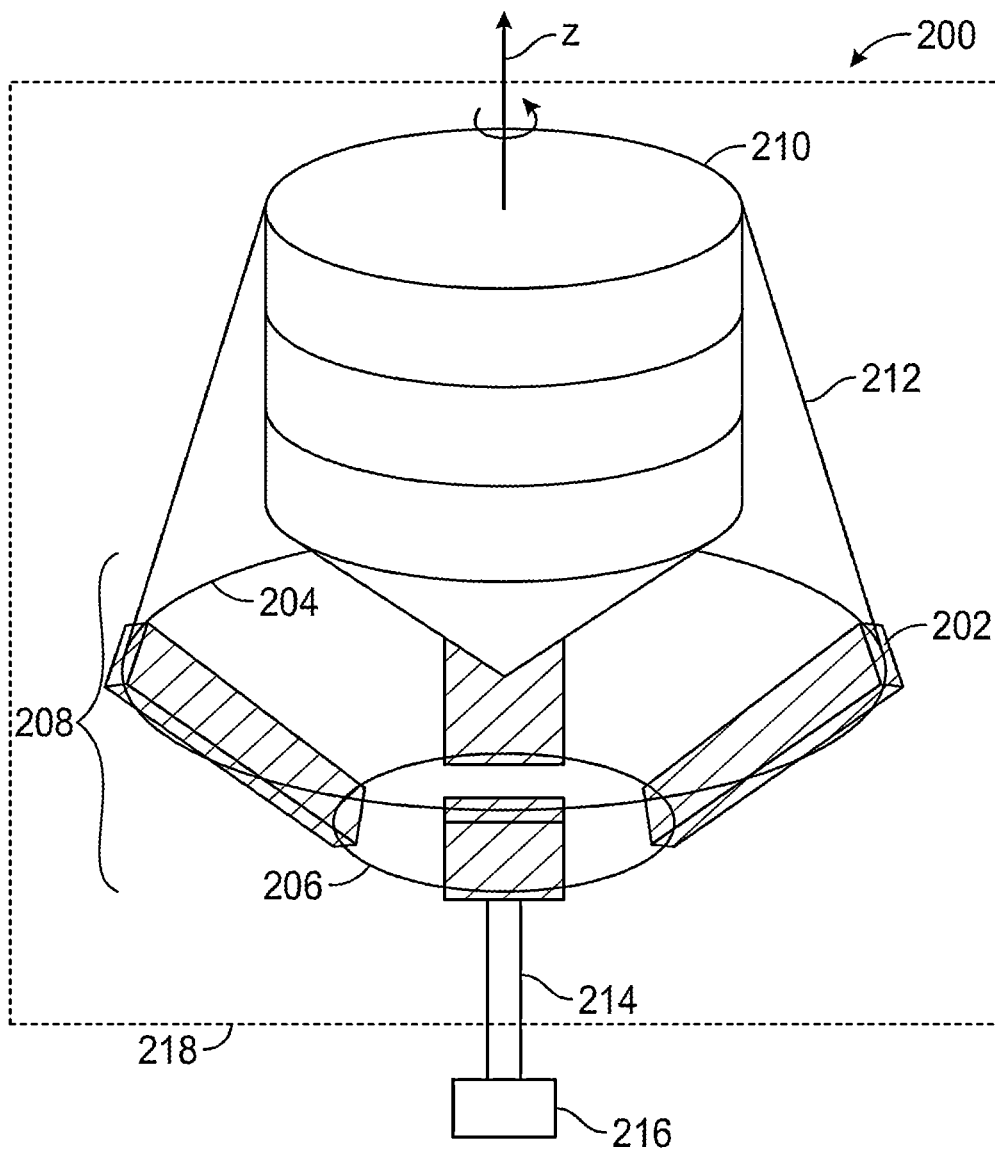

FIG. 2A

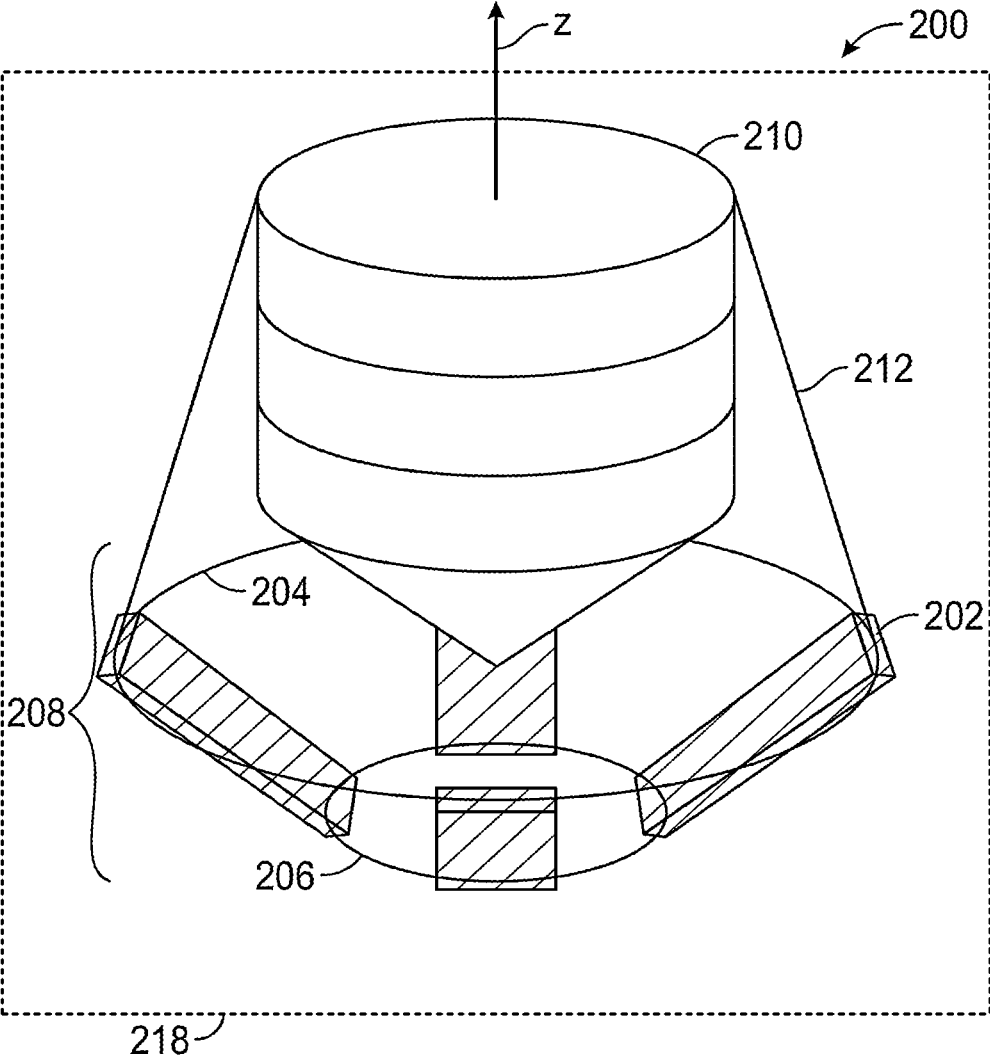

FIG. 2B

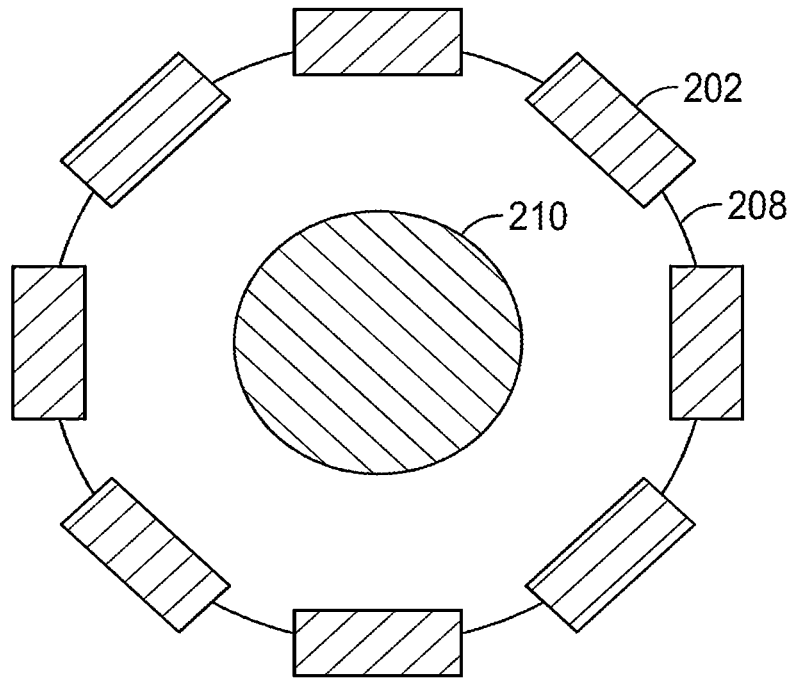

FIG. 3A

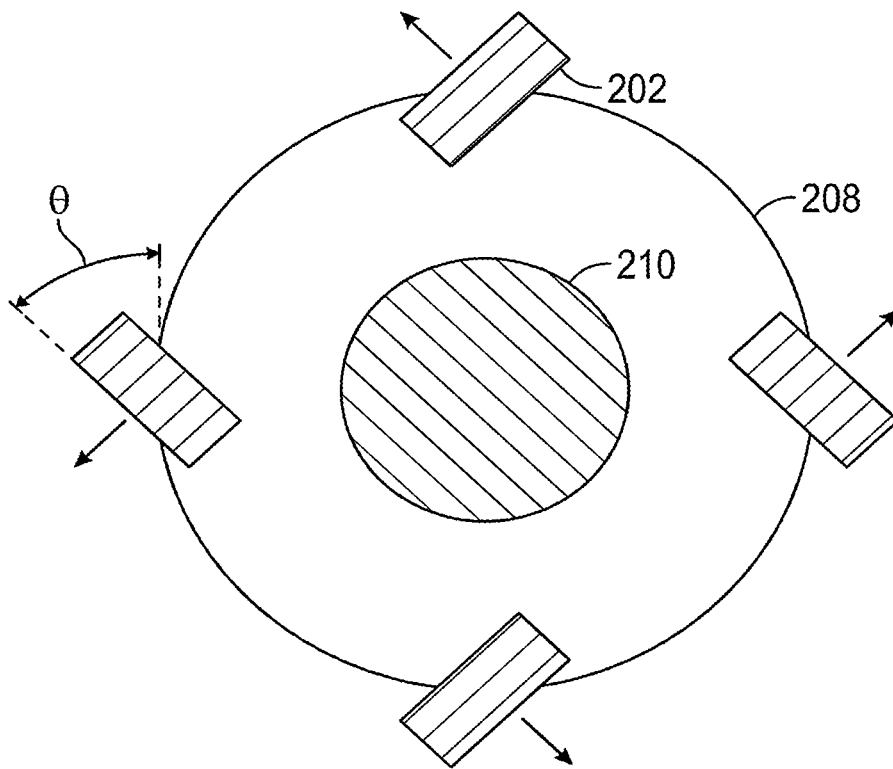

FIG. 3B

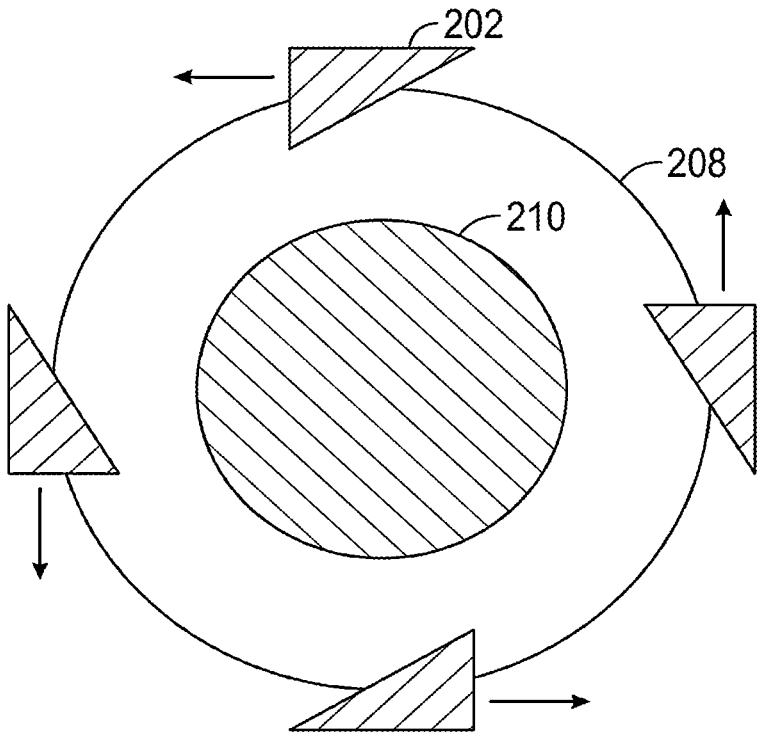

FIG. 3C

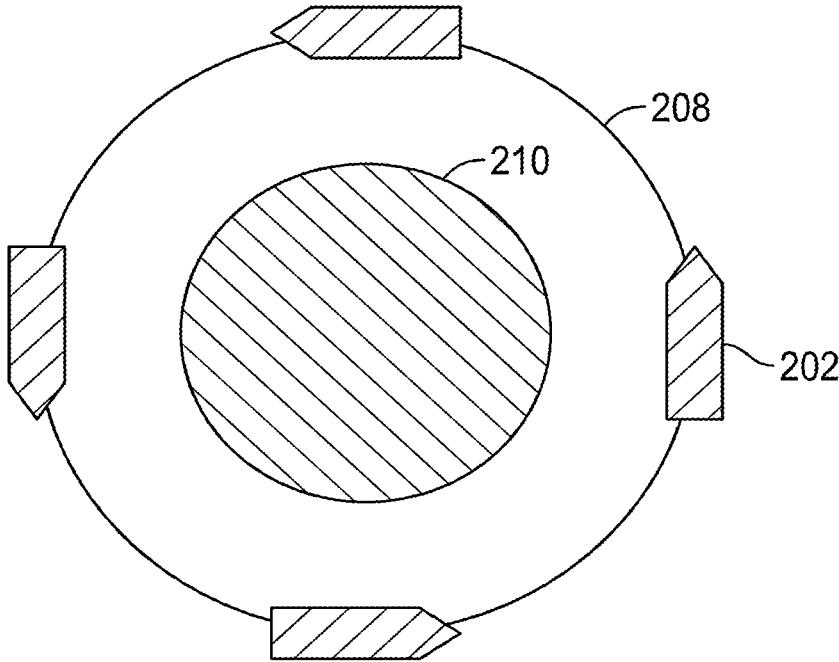

FIG. 3D

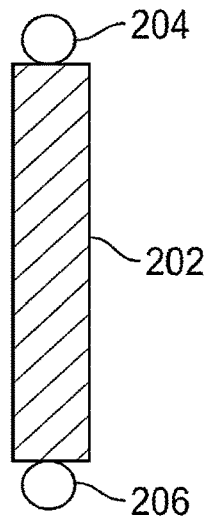

FIG. 4A

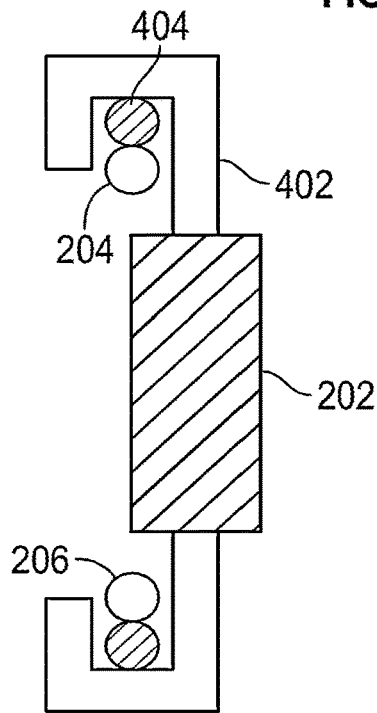

FIG. 4B

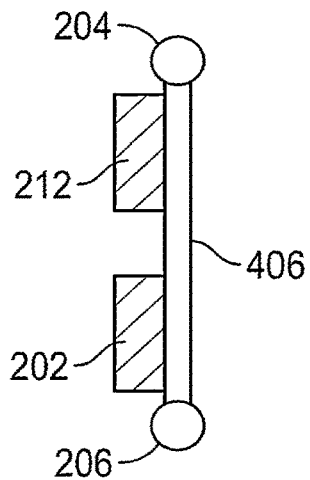

FIG. 4C

**CENTRIPETAL MAGNET ACCELERATOR
UTILIZING MAGNETS TO PRODUCE
ROTATIONAL MOTION FOR GENERATING
ELECTRICITY**

CROSS-REFERENCE TO RELATED PATENT
APPLICATIONS

This application is a continuation of U.S. patent application Ser. No. 17/891,040, filed Aug. 18, 2022, entitled CENTRIPETAL MAGNET ACCELERATOR UTILIZING MAGNETS TO PRODUCE ROTATIONAL MOTION FOR GENERATING ELECTRICITY, which is a continuation of U.S. patent application Ser. No. 17/465,389, now U.S. Pat. No. 11,451,125, entitled CENTRIPETAL MAGNET ACCELERATOR, filed Sep. 2, 2021, which is a continuation of International Patent Application No. PCT/US2021/026021, filed Apr. 6, 2021, which claims the benefit of and priority to U.S. Provisional Patent Application No. 63/146,619, filed Feb. 6, 2021, and U.S. Provisional Patent Application No. 63/005,538, filed Apr. 6, 2020, all of which are incorporated herein by reference in their entireties.

BACKGROUND

The present disclosure relates generally to a device for generating electricity. More specifically, the present disclosure relates to a device that utilizes the attraction and repulsion of magnets to produce rotational motion for generating electricity.

In today's day and age, we face an ever-increasing demand for clean and renewable sources of electrical energy. Clean and renewable energies can help to reduce pollution and carbon dioxide (CO₂) emissions, and can even provide energy to people and/or places that current lack access to safe and reliable electricity. Thus, technologies that can generate clean energy with little to no resource consumption may be desirable to meet global energy demands.

SUMMARY

One embodiment of the present disclosure is an assembly for generating electricity. The assembly includes a circular track configured to rotate about a first axis of rotation, the circular track comprising a first magnet having a face that is at an angle with respect to the first axis of rotation, a second magnet positioned at a center of the circular track, wherein a face of the second magnet is an opposite polarity to the face of the first magnet such that the second magnet repels the first magnet to rotate the circular track, and a device for converting rotational motion from the circular track into electricity.

In some embodiments, the circular track further includes a plurality of magnets in addition to the first magnet, and each of the plurality of magnets and the first magnet are equally spaced around the circumference of the circular track.

In some embodiments, the assembly further includes a plurality of magnets in addition to the second magnet, and the plurality of magnets are stacked on a top side of the second magnet to increase a magnetic strength of the second magnet.

In some embodiments, the second magnet is in the shape of a cone, a pyramid, a hemisphere, a conical frustum, or a cylinder.

In some embodiments, the second magnet is formed by a plurality of magnets positioned on an outer surface of a

support member, the support member in the shape of a cone, a pyramid, a hemisphere, a conical frustum, or a cylinder.

In some embodiments, the first magnet is triangular in shape such that the face of the first magnet is at an angle with respect to the first axis of rotation and a side of the first magnet opposite the face is perpendicular to the first axis of rotation.

In some embodiments, the assembly further includes one or more support members extending from the circular track to the second magnet to support the second magnet.

In some embodiments, the assembly further includes a housing configured to enclose the circular track and the second magnet, and the housing is structured to maintain a vacuum.

In some embodiments, the assembly for converting rotational motion from the circular track into electricity is an electromagnetic device including a rotor and a stator. In some embodiments, other movement harnessing devices may be used to convert rotational motion from the circular track into electricity.

In some embodiments, the assembly further includes a shaft extending from the device for converting rotational motion from the circular track into electricity to the circular track, the shaft defining the first axis of rotation.

In some embodiments, the assembly further includes a gear set positioned between the device for converting rotational motion from the circular track into electricity and the shaft, the gear set configured to increase or decrease a rotational speed of the device for converting rotational motion from the circular track into electricity according to one or more different gear ratios.

In some embodiments, at least one of the first magnet or the second magnet are electromagnets, and a portion of the electricity generated by the electromagnetic device is utilized to power the at least one of the first magnet or the second magnet.

In some embodiments, the circular track is constructed from a conductive material such that the portion of the electricity utilized to power the first magnet is provided to the first magnet via the circular track.

In some embodiments, the circular track further includes an upper track and a lower track, and the first magnet is positioned between the upper track and the lower track.

In some embodiments, the lower track has a smaller radius than the upper track.

BRIEF DESCRIPTION OF THE DRAWINGS

Objects, aspects, features, and advantages of the disclosure will become more apparent and better understood by referring to the detailed description taken in conjunction with the accompanying drawings, in which like reference characters identify corresponding elements throughout. In the drawings, like reference numbers generally indicate identical, functionally similar, and/or structurally similar elements.

FIG. 1 is a block diagram of a system for generating electricity, according to some embodiments.

FIGS. 2A and 2B are diagrams of centripetal magnet accelerators, according to some embodiments.

FIGS. 3A-3D are example configurations of a magnets along a track of the centripetal magnet accelerators of FIGS. 2A and 2B, according to some embodiments.

FIGS. 4A-4C are example configurations for coupling magnets to the track of the centripetal magnet accelerators of FIGS. 2A and 2B, according to some embodiments.

DETAILED DESCRIPTION

Before turning to the figures, which illustrate certain exemplary embodiments in detail, it should be understood that the present disclosure is not limited to the details or methodology set forth in the description or illustrated in the figures. It should also be understood that the terminology used herein is for the purpose of description only and should not be regarded as limiting.

Referring generally to the FIGURES, a device for generating electricity using the effects of magnetic attraction and repulsion is shown, according to some embodiments. In particular, the device may include a first magnet or a set of magnets positioned around a circular track assembly, with a second magnet or set of magnets at or near the center of the circular track assembly. As described herein, the first and second magnets, or sets of magnets, may be permanent magnets (e.g., neodymium), electromagnetics, or superconducting magnets. The first and second magnets or sets of magnets may be positioned such that the faces (e.g., a side of the first magnet substantially facing the second magnet, or vice versa) of these magnets have opposite polarities. For example, a face of the first magnet may constitute the north pole of the magnet, while a face of the second magnet may constitute the south pole of the magnet. Thus, the first and second magnets may repel each other.

In some embodiments, the second magnet may be fixed in position with respect to the first magnet and/or the circular track assembly, such that the force of the second magnet repelling the first magnet causes at least one of the first magnet or the entire circular track assembly to rotate about an axis of rotation (e.g., at the center of the circular track assembly). This rotational motion may be harnessed to rotate a shaft connected to an electromagnetic device (e.g., a generator), and the electromagnetic device may be configured to convert this rotational motion into electrical energy. Advantageously, this device may require little to no energy to operate, instead relying on the inherent attraction and/or repulsion of two collocated magnets to produce electricity. Further, as will be made evident in the present disclosure, this device may occupy a much smaller footprint than other electricity producing devices.

Referring first to FIG. 1, a block diagram of a system 100 for generating electricity is shown, according to some embodiments. Unlike many other systems for generating electricity, system 100 may provide clean and renewable electricity while requiring little to no input energy (e.g., electricity, natural gas, coal, etc.) to operate. Instead, as mentioned above, system 100 may harness the attraction and repulsion of magnets to rotate an electromagnetic device for generating electricity. In particular, system 100 includes an accelerator 102, as referred to herein as a centripetal magnet accelerator, which includes at least two magnets positioned such that opposing poles (e.g., north and south) of the magnets are at least partially facing each other. Thus, the opposing poles cause a repulsive force between the two magnets, driving the magnets away from each other.

Accelerator 102 may include a circular track assembly, or other similar track assembly, to which at least one of the magnets can be coupled. In some embodiments, the circular track assembly is configured to rotate about a central axis of rotation. In other embodiments, the magnet is movably coupled to the circular track assembly, such that the magnet may travel around the circular track. In either case, the remaining magnet or magnets may be positioned in a center of the circular track assembly, opposing the magnet coupled to the circular track and thereby “pushing” (e.g., by a

repulsive force) the first magnet around the track and/or rotating the circular track assembly. Accelerator 102 is described in greater detail below with respect to FIGS. 2A and 2B.

Accelerator 102 may be coupled to gears 104, such as by a connecting shaft (e.g., a drive shaft, a prop shaft, etc.). Gears 104 may be a gear set including one or more spur gears, helical gears, bevel gears, miter gears, worm gears, screw gears, planetary gears, etc., configured to either increase or decrease the rotational speed (i.e., increase or decrease the angular velocity) of the shaft, and in some cases configured to reverse the direction of rotation of the shaft. Accordingly, system 100 may include an input shaft that couples accelerator 102 to gears 104, and an output shaft that couples gears 104 to a generator 106. In some embodiments, gears 104 may be selectively engaged to adjust the speed of rotation of the output shaft, and thus the speed of rotation of generator 106, as discussed in greater detail below.

Generator 106 may be any electromagnetic device configured to convert rotational motion into electrical energy. For example, generator 106 may include a stator formed by a conductive wire wound on a metal core, and a rotor formed by one or more magnets positioned on a circular housing (e.g., a metal hoop or flat-bottomed bowl). The rotor may be rotated by the output shaft of gears 104, thereby generating a rotating magnetic field that induces a voltage difference between the windings of the stator, producing alternating current (AC). In some embodiments, generator 106 may include a voltage regulator for regulating the output voltage of the device, and/or may include a converter for converting the output AC of generator 106 to direct current (DC). A generator that uses a copper coil may be used. The generator may be a turbine generator. The generator may be rotated by a device other than the gears and connecting shaft 214. In some embodiments the bottom of the circular track assembly 208 defines a single gear that rotates and another gear(s) may fit into the bottom circular track assembly 208 gear perpendicularly, where the perpendicular gear(s) may be attached to a rod that rotates a generator to produce electricity.

In some embodiments, as discussed in greater detail below, one or more of the magnets included in accelerator 102 may be electromagnets, which produce a magnetic field with the application of an electric current. For example, a basic electromagnet can be formed by wrapping a length of conductive wire (e.g., copper) around a metal core. An electric current can then be applied to the conductive wire, producing the magnetic field. In some such embodiments, generator 106 may be configured to provide at least a portion of the produced electricity to accelerator 102, in order to power the electromagnets.

Referring now to FIGS. 2A and 2B, a diagram of a centripetal magnet accelerator 200 is shown, according to some embodiments. Accelerator 200 may be the same as, or nearly the same as, accelerator 102 described above, for example. Accordingly, accelerator 200 may be configured to produce rotational motion, which can be converted into electricity by an electromagnetic device (e.g., generator 106). Advantageously, accelerator 200 may consume little to no energy to produce said rotational motion, and may therefore be more cost and energy-efficient than other devices for generating electricity. Additionally, as mentioned above, accelerator 200 may produce little to no emissions, resulting in clean and renewable energy.

Accelerator 200 is shown to include a plurality of first magnetic units 202. In some embodiments, first magnetic units 202 may be individual magnets, or may include a plurality of magnets (e.g., stacked, positioned side-by-side,

etc.). For example, first magnetic units **202** may include a single, rectangular bar magnet as shown in FIGS. **2A** and **2B**, though it will be appreciated that first magnetic units **202** may include any number, shape, and/or size of magnets. In the example shown, accelerator **200** includes at least four of first magnetic units **202**, although it will also be appreciated that accelerator **200** can include any number of first magnetic units **202**. Additional configurations of first magnetic units **202** are described in greater detail below, with respect to FIGS. **3A-3D**.

Each of first magnetic units **202** is coupled (e.g., permanently, movably, or removably) to an upper circular track **204** and/or a lower circular track **206**. Together, upper circular track **204** and lower circular track **206** form a circular track assembly **208** configured to support first magnetic units **202**. In some embodiments, upper circular track **204** and lower circular track **206** are fixedly or removably coupled by one or more support members (not shown). For example, support members may extend from upper circular track **204** to lower circular track **206**, or may extend from one or both of upper circular track **204** and lower circular track **206** to another mounting surface (e.g., a housing **218**, as described below). In some embodiments, circular track assembly **208** is configured to rotate about a central axis of rotation **z**, as discussed in greater detail below. In other embodiments, circular track assembly **208** is fixed in rotation, and first magnetic units **202** are configured to rotate around circular track assembly **208**.

In some embodiments, such as the embodiment shown in FIGS. **2A** and **2B**, lower circular track **206** has a smaller radius than upper circular track **204**. In other embodiments, upper circular track **204** and lower circular track **206** have a similar or identical radius. One or both of upper circular track **204** and lower circular track **206** may be formed from lightweight materials, such as aluminum, thereby reducing the weight of circular track assembly **208** and accelerator **200**. In some embodiments, upper circular track **204** and/or lower circular track **206** are formed of a conductive material (e.g., aluminum, iron, etc.) such that electricity may be passed through upper circular track **204** and lower circular track **206**, and provided to first magnetic units **202**.

Accelerator **200** is also shown to include a second magnetic unit **210**. Second magnetic unit **210** may include one or more magnets and may be positioned at a center of circular track assembly **208** (e.g., and thereby accelerator **200**). Second magnetic unit **210** may be configured to provide a repulsive force against first magnetic units **202**, thereby causing first magnetic units **202** and/or circular track assembly **208** to rotate. Accordingly, a face of second magnetic unit **210** may be an opposite polarity of a face of each of first magnetic units **202**. For example, the face of second magnetic unit **210** may be configured as a north pole, while the face of each of first magnetic units **202** may be configured as a south pole. In this manner, when first magnetic units **202** and second magnetic unit **210** are brought in close proximity, the magnetic fields of first magnetic units **202** and second magnetic unit **210** may oppose one another, causing a repulsive force. Additionally, rotational motion may be at least partially sustained due to the centripetal force of the rotating first magnetic units **202** and/or circular track assembly **208**.

This repulsive force, caused by the opposing polarities of the faces of first magnetic units **202** and second magnetic unit **210**, causes either the first magnetic units **202** or the circular track assembly **208** to rotate about an axis of rotation. The axis of rotation, **z**, may be defined by a connecting shaft **214**, configured to transfer the rotational

motion of first magnetic units **202** and/or circular track assembly **208** to an electromagnetic device **216** (e.g., a generator). In other words, the rotation of first magnetic units **202** and/or circular track assembly **208** may cause connecting shaft **214** to rotate, thereby causing components (e.g., a rotor) of electromagnetic device **216** to rotate to produce electricity. Accordingly, connecting shaft **214** may be coupled to one or more of first magnetic units **202** and/or circular track assembly **208**, depending on a configuration of accelerator **200**.

In some embodiments, as discussed above with respect to FIG. **1**, accelerator **200** may include more than one connecting shaft **214**. In such embodiments, accelerator **200** may also include a gear set (e.g., gears **104**) positioned between accelerator **200** and electromagnetic device **216**, in order to increase or decrease the speed at which electromagnetic device **216** rotates. For example, a first connecting shaft may couple first magnetic units **202** and/or circular track assembly **208** to the gear set, while a second connecting shaft couples the gear set to electromagnetic device **216**. In some embodiments, a ratio of the gear set may be selectively modified to adjust the rotational speed of electromagnetic device **216**.

In some embodiments, such as the embodiments shown in FIGS. **2A** and **2B**, second magnetic unit **210** includes at least one cone-shaped magnet at the lowermost portion of the unit. A cone-shaped second magnetic unit **210** may provide an even magnetic field, and thus an evenly distributed repulsive force against first magnetic units **202**. However, it will be appreciated that second magnetic unit **210**, or at least the lowermost portion of second magnetic unit **210**, may be any suitable shape. For example, at least a portion of second magnetic unit **210** may be shaped as a cone, a pyramid, a hemisphere, a conical frustum, a cylinder, etc.

In some embodiments, second magnetic unit **210** may include a lightweight support structure (e.g., an aluminum cylinder or cone) to which a plurality of smaller magnets may be mounted. Accordingly, in such embodiments, the face or surface of second magnetic unit **210** may be formed of multiple individual magnets, rather than one continuous magnet. Additionally, in some embodiments, the lightweight support structure may be shaped in any of a cone, a pyramid, a hemisphere, a conical frustum, a cylinder, etc. In some embodiments, the conical portion of second magnetic unit **210** may be formed from a plurality of wedge-shaped magnets having a common strength and size.

In some embodiments, second magnetic unit **210** includes multiple magnets that are stacked or otherwise positioned such that the magnetic fields of the magnets combine to increase the overall strength of second magnetic unit **210**. As shown, for example, a plurality of cylindrical magnets may be stacked on a cone shaped magnet to form second magnetic unit **210**. Thus, in some embodiments, second magnetic unit **210** is stronger than first magnetic units **202** (e.g., second magnetic unit **210** has a stronger magnetic field). In this manner, the force provided by second magnetic unit **210** against first magnetic units **202** may be significantly stronger than the force provided by first magnetic units **202** against second magnetic unit **210**, causing first magnetic units **202** and/or circular track assembly **208** to rotate.

In some embodiments, second magnetic unit **210** is supported by one or more support arms **212**. Support arms **212** may extend from second magnetic unit **210** to one or more portions of circular track assembly **208** (e.g., upper circular track **204**) as shown, or may extend to housing **218** or to another support structure (not shown). Support arms **212** may be configured to position second magnetic unit **210** at

the center of circular track assembly **208**, and/or above circular track assembly **208**. As shown, for example, second magnetic unit **210** is above circular track assembly **208** such that the cone portion of second magnetic unit **210** extends into the center of circular track assembly **208**, thereby positioned in close proximity to first magnetic units **202**.

In some embodiments, support arms **212** are adjustable, allowing second magnetic unit **210** to be raised and/or lowered. Raising second magnetic unit **210** away from first magnetic units **202** may decrease the repulsive force between the two components, causing first magnetic units **202** and/or circular track assembly **208** to rotate more slowly, thereby producing less energy. Lowering second magnetic unit **210** toward first magnetic units **202** may increase the repulsive force between the two components, causing first magnetic units **202** and/or circular track assembly **208** to rotate more quickly, thereby producing more energy.

In some embodiments, second magnetic unit **210** may be lowered such that all or at least a significant portion of second magnetic unit **210** is within circular track assembly **208**, and thereby in close proximity to first magnetic units **202**. Like circular track assembly **208**, support arms **212** may be constructed of lightweight and/or conductive materials, such as aluminum, to reduce the weight of accelerator **200** and/or to provide electricity to any of first magnetic units **202** and second magnetic unit **210**.

In some embodiments, as mentioned above, either one or both of first magnetic units **202** and second magnetic unit **210** may be electromagnets, rather than permanent (e.g., neodymium) magnets. In such embodiments, at least a portion of the electricity produced by electromagnetic device **216** may be provided to first magnetic units **202** and/or second magnetic unit **210** to power the electromagnets. In some such embodiments, electricity may be provided via connecting shaft **214**, lower circular track **206**, upper circular track **204**, and/or support arms **212**, and thus, as mentioned above, any of these components of accelerator **200** may be constructed from lightweight but conductive materials.

Housing **218**, as mentioned briefly above, is configured to enclose at least a portion of the device. In the example shown, housing **218** may enclose everything other than electromagnetic device **216**, and a portion of connecting shaft **214**. However, it will be appreciated that in other cases, additional or fewer components of accelerator **200** may be enclosed by housing **218**. For example, in some cases, electromagnetic device **216** may also be enclosed. In some embodiments, housing **218** is formed of a lightweight material such as aluminum, plastic, etc. In some embodiments, components of accelerator **200** such as support arms **212** may be coupled to housing **218**, and thus housing **218** may be formed of a material strong enough to support these components and to withstand the forces (e.g., rotation motion) produced by accelerator **200** during operation.

In some embodiments, housing **218** is air-tight such that housing **218** may hold a vacuum. Enclosing the components of accelerator **200** in a vacuum can help to reduce the effects of wind resistance (e.g., drag), which may slow the rotation of first magnetic units **202** and/or circular track assembly **208**, thus resulting in wasted energy. In some such embodiments, housing **218** may include a seal (not shown), through which connecting shaft **214** may pass, to allow housing **218** to maintain a vacuum without inhibiting the rotation of connecting shaft **214**. In other embodiments, as mentioned

above, connecting shaft **214** and/or electromagnetic device **216** may be completely enclosed or completely outside of housing **218**.

In some embodiments, multiple accelerators (e.g., multiple of accelerator **200**) may be operated in unison to drive (e.g., rotate) either a single connecting shaft **214**, or multiple connecting shafts. In this manner, the output of each accelerator **200** may be combined to increase the electricity produced. For example, multiple accelerators may power a single electromagnetic device (e.g., electromagnetic device **216**) to increase the electricity produced by the electromagnetic device. In another example, multiple accelerators may provide rotational energy to a gear set, which combines the energy from the multiple accelerators and outputs the combined rotational energy to an electromagnetic device.

In some embodiments, one or a plurality of accelerators (e.g., multiple of accelerator **200** without connecting shaft **214** and electromagnetic device **216**) are positioned on a circular track assembly and configured to rotate about the circular track assembly. In such embodiments, a plurality of first magnetic units **202** and/or circular track assembly **208** may rotate about an axis of rotation, however each accelerator **200** (without connecting shaft **214** and electromagnetic device **216**) may also move upwards (e.g., moving along the axis *z* of FIG. 2) and the movement of the accelerator **200** (without connecting shaft **214** and electromagnetic device **216**) is harnessed to produce electricity. In some embodiments, a plurality of first magnetic units **202** and/or circular track assembly **208** may not rotate about an axis of rotation and each accelerator **200** (without connecting shaft **214** and electromagnetic device **216**) may move upwards (e.g., moving along the axis *z* of FIGS. 2A and 2B). Second magnet units **210** may not rotate in such embodiments where the accelerator unit moves along the *z* axis. In some such embodiments, the accelerators are positioned horizontally on the circular track, thereby rotating about the track and/or causing the track to rotate about a second axis of rotation. In some such embodiments, the circular track may be completely filled with accelerators, such that the plurality of accelerators are positioned end-to-end in a "train." In some such embodiments, housing **218** may be an aerodynamic shape (e.g., a cone) to reduce drag on each of the plurality of accelerators as they rotate. In some embodiments, a plurality of circular tracks each including one or a plurality of accelerators may be stacked or positioned in a manner to allow each of the circular tracks and/or accelerators to turn a common shaft or other motion harnessing device, thereby increasing the rotational energy and the amount of electricity generated.

In some embodiments, a single accelerator (e.g., accelerator **200**) may include multiple circular track assemblies (e.g., multiple of circular track assembly **208**) and/or multiple second magnetic units (e.g., multiple of second magnetic unit **210**). For example, two or more circular track assemblies, each including a plurality of first magnetic units **202**, may be stacked in series. In this manner, the rotational motion from each circular track assemblies and/or the first magnetic units **202** of each circular track assemblies may be combined to drive a single connecting shaft **214**. In some such embodiments, each circular track assembly **208** may be the substantially the same size (e.g., in diameter), such that the multiple circular track assemblies are aligned. In some embodiments, a plurality of stacked circular track assemblies are spaced apart such that the circular track assemblies and/or the first magnetic units **202** of each circular track assembly may rotate freely. In some such embodiments, a connecting shaft may span a length of the stacked circular

track assemblies (e.g., at a center of the circular track assemblies) to transfer the rotational energy of all of the circular track assemblies.

Referring now to FIGS. 3A-3D, example configurations of magnets (e.g., first magnetic units 202) along circular track assembly 208 of accelerator 200 are shown, according to some embodiments. In particular, each of FIGS. 3A-3D may represent a top-down perspective view of accelerator 200, as described in detail above. Turning first to FIG. 3A, an example configuration is shown that includes eight of first magnetic units 202 positioned around circular track assembly 208. As shown, each of first magnetic units 202 may be equidistantly spaced around circular track assembly 208, with second magnetic unit 204 positioned at the center of circular track assembly 208. However, in other embodiments, first magnetic units 202 may not be equally spaced, or there may be no space between each of first magnetic units 202. In some embodiments, each of first magnetic units 202 are positioned at the same height along circular track assembly 208 (e.g., equidistant between upper circular track 204 and lower circular track 206). In other embodiments, each of first magnetic units 202 are positioned at different heights along circular track assembly 208.

As discussed above, in some embodiments, circular track assembly 208 may be configured to rotate about an axis of rotation, which may extend through the center of second magnetic unit 210. In other embodiments, each of first magnetic units 202 may be configured to rotate around second magnetic unit 210, by following circular track assembly 208. To achieve this rotational motion, second magnetic unit 210 may repel first magnetic units 202. In other words, the magnetic field of second magnetic unit 210 may interact with the magnetic fields of first magnetic units 202, thereby exert a force on first magnetic units 202 and/or circular track assembly 208, causing first magnetic units 202 and/or circular track assembly 208 to rotate (i.e., spin) about the axis of rotation.

In some embodiments, each of first magnetic units 202 may be constructed from a plurality of magnets that vary in strength. For example, first magnetic units 202 may be constructed from a plurality of thin, elongated, rectangular shaped magnets positioned next to one another to form a magnetic unit. The thin magnets or magnetic sections may increase in strength in a direction of rotation of first magnetic units 202 and/or circular track assembly 208. For example, if the device of FIG. 3A is configured to rotate counter-clockwise, the weakest magnetic section may be positioned on the rightmost side of each of first magnetic units 202, while the strongest magnetic section is placed on the leftmost side of each of first magnetic units 202. In this manner, the leftmost side of first magnetic units 202 may produce a much stronger magnetic field than the rightmost side of first magnetic units 202, resulting in an increased repulsive force due to second magnetic unit 210. The increase in repulsive force on only one side of each of first magnetic units 202 therefore causes first magnetic units 202 and/or circular track assembly 208 to rotate about the axis of rotation.

In some embodiments, rather than a plurality of individual magnets, first magnetic units 202 may include a single, ring-shaped magnet. In such embodiments, one or both of upper circular track 204 or lower circular track 206 may be replaced with the ring-shaped magnet, or the ring-shaped magnet may be mounted to another support surface (not shown). In some embodiments, the ring-shaped magnet may not rotate, but rather accelerator 200 (without connecting

shaft 214 and electromagnetic device 216) may move upwards along the z axis of FIGS. 2A and 2B.

In some embodiments, first magnetic units 202 are positioned at an angle θ with respect to the axis of rotation, as shown in FIG. 3B. Specifically, first magnetic units 202 may be positioned such that a face of each magnet is at an angle other than perpendicular with the axis of rotation. By angling at least the face of first magnetic units 202 in this manner, a portion of the force applied to each magnet due to the repulsion from second magnetic unit 210 may be directed towards the direction of rotation of the device. In other words, at least a portion of the force applied to each of first magnetic units 202 is perpendicular to the axis of rotation, thereby causing the device to rotate. For example, in FIG. 3B, the force applied to each of first magnetic units 202 is shown as an arrow that is pointing at least partially counter-clockwise, rather than directly outwards from the center of accelerator 200. Accordingly, the force of repulsion due to the opposing poles of first magnetic units 202 and second magnetic unit 210 may cause first magnetic units 202 and/or circular track assembly 208 to rotate in a counter-clockwise direction.

It will also be appreciated that first magnetic units 202 may be any suitable shape, and thus the examples shown and described above are not intended to be limiting. For example, first magnetic units 202 may be shaped as right triangular prisms, as shown in FIG. 3C, or first magnetic units 202 may be any other polygonal shape. As right triangular prisms, a face of each of first magnetic units 202 may be positioned at an angle with respect to the axis of rotation (e.g., other than perpendicular), without having to angle first magnetic units 202 themselves. Thus, the force of repulsion due to the opposing poles of first magnetic units 202 and second magnetic unit 210 may cause first magnetic units 202 and/or circular track assembly 208 to rotate in a counter-clockwise direction in a similar manner to the configuration of FIG. 3B, described above.

As shown in FIG. 3C, for example, a face of each of first magnetic units 202 (e.g., the hypotenuse of the triangular shaped magnets) is at an angle to the axis of rotation, while the two remaining sides of the first magnetic units 202 are parallel and/or perpendicular to the axis of rotation. In this manner, a force applied to the face of first magnetic units 202 may result in a force at least partially perpendicular to the axis of rotation, causing the device to rotate. Additionally, first magnetic units 202 as shown in FIG. 3C may have a larger amount of magnetic (e.g., ferrous) material along one side of the magnet (e.g., the leading edge), thus increasing the repulsive force at the leading edge of the magnet. In some embodiments, the increased repulsive force in the configuration of FIG. 3C may result in an increased rotational speed of first magnetic units 202 and/or circular track assembly 208, which can result in increased electricity production.

In some embodiments, a position of each of first magnetic units 202 may be rotated and/or flip (e.g., horizontally or vertically) with respect to the configuration shown in FIG. 3C, such that either the opposite or adjacent sides of the triangular magnets is closest to second magnetic unit 210 (e.g., rather than the hypotenuse). In such embodiments, the repulsive force from second magnetic unit 210 may be stronger on one side of first magnetic units 202 (e.g., the widest side, with more magnetic material), causing first magnetic units 202 and/or circular track assembly 208 to rotate.

In some cases, it is also advantageous for first magnetic units 202 to be aerodynamic, to reduce the effects of drag

11

due to wind resistance as first magnetic units **202** and/or circular track assembly **208** rotate. As shown in FIG. 3D, for example, first magnetic units **202** may have an aerodynamic edge or tip (e.g., a pointed cone, a triangular prism, etc.) configured to reduce the effects of wind resistance, thus reducing the loss of angular momentum as first magnetic units **202** and/or circular track assembly **208** rotate.

Referring now to FIGS. 4A-4C, example configurations for coupling magnets (e.g., first magnetic units **202**) to circular track assembly **208** of accelerator **200** are shown, according to some embodiments. As discussed above, for example, first magnetic units **202** may be permanently, removably, and/or movably coupled to upper circular track **204** and/or lower circular track **206** depending on a configuration of accelerator **200**. While a number of configurations are shown in FIGS. 4A-4C, it will be appreciated that other suitable methods or systems for coupling first magnetic units **202** to circular track assembly **208** are also contemplated herein. Thus, the examples described below are not intended to be limiting.

Turning first to FIG. 4A, a configuration of permanently and/or fixedly coupling first magnetic units **202** to circular track assembly **208** is shown. The configuration shown may be utilized in a configuration of accelerator **200** where circular track assembly **208** rotates and first magnetic units **202** remain stationary with respect to circular track assembly **208**. In particular, one of first magnetic units **202** is shown to be coupled directly to upper circular track **204** and lower circular track **206**. In some embodiments, this configuration is achieved by welding or bolting first magnetic units **202** to upper circular track **204** and lower circular track **206**. In other embodiments, another method of fixing first magnetic units **202** to upper circular track **204** and lower circular track **206** is utilized.

In some embodiments, as discussed above, first magnetic units **202** may rotate about circular track assembly **208**, while circular track assembly **208** remains relatively stationary. Accordingly, first magnetic units **202** may be coupled to upper circular track **204** and lower circular track **206** by one or more brackets **402**, as shown in FIG. 4B. In some embodiments, brackets **402** may be separated from upper circular track **204** and lower circular track **206** by roller assemblies **404**. Roller assemblies **404** may include wheels, bearings, or any other component that can support brackets **402** on upper circular track **204** and lower circular track **206**, while allowing first magnetic units **202** to move along upper circular track **204** and lower circular track **206**. In other words, roller assemblies **404** allow first magnetic units **202** to rotate freely about circular track assembly **408**.

In some embodiments, first magnetic units **202** are mounted to a mounting surface **406**, rather than being coupled directed to upper circular track **204** and lower circular track **206**, as shown in FIG. 4C. In some such embodiments, mounting surface **406** may be a plate (e.g., aluminum sheet metal) to which first magnetic units **202** may be bolted, welded, or otherwise secured. In the example shown, two of first magnetic units **202** are mounted on mounting surface **406**, and mounting surface **406** is coupled to upper circular track **204** and lower circular track **206**. In some embodiment, mounting surface **406** is directed coupled to upper circular track **204** and lower circular track **206** by welding, bolting, etc., such that first magnetic units **202** are fixed to circular track assembly **208**, and circular track assembly **208** rotates about the axis of rotation. In other embodiment, mounting surface **406** is removably or movably (e.g., slidably) coupled to upper circular track **204**

12

and lower circular track **206** such that first magnetic units **202** are free to rotate about to circular track assembly **208**.

The present disclosure contemplates methods, systems, and program products on any machine-readable media for accomplishing various operations. The embodiments of the present disclosure may be implemented using existing computer processors, or by a special purpose computer processor for an appropriate system, incorporated for this or another purpose, or by a hardwired system. Embodiments within the scope of the present disclosure include program products comprising machine-readable media for carrying or having machine-executable instructions or data structures stored thereon. Such machine-readable media can be any available media that can be accessed by a general purpose or special purpose computer or other machine with a processor. By way of example, such machine-readable media can comprise RAM, ROM, EPROM, EEPROM, CD-ROM or other optical disk storage, magnetic disk storage or other magnetic storage devices, or any other medium which can be used to carry or store desired program code in the form of machine-executable instructions or data structures and which can be accessed by a general purpose or special purpose computer or other machine with a processor. When information is transferred or provided over a network or another communications connection (either hardwired, wireless, or a combination of hardwired or wireless) to a machine, the machine properly views the connection as a machine-readable medium. Thus, any such connection is properly termed a machine-readable medium. Combinations of the above are also included within the scope of machine-readable media. Machine-executable instructions include, for example, instructions and data which cause a general purpose computer, special purpose computer, or special purpose processing machines to perform a certain function or group of functions.

As utilized herein, the terms “approximately,” “about,” “substantially,” and similar terms are intended to have a broad meaning in harmony with the common and accepted usage by those of ordinary skill in the art to which the subject matter of this disclosure pertains. It should be understood by those of skill in the art who review this disclosure that these terms are intended to allow a description of certain features described and claimed without restricting the scope of these features to the precise numerical ranges provided. Accordingly, these terms should be interpreted as indicating that insubstantial or inconsequential modifications or alterations of the subject matter described and claimed are considered to be within the scope of the invention as recited in the appended claims.

It should be noted that the terms “exemplary” and “example” as used herein to describe various embodiments is intended to indicate that such embodiments are possible examples, representations, and/or illustrations of possible embodiments (and such term is not intended to connote that such embodiments are necessarily extraordinary or superlative examples).

The terms “coupled,” “connected,” and the like, as used herein, mean the joining of two members directly or indirectly to one another. Such joining may be stationary (e.g., permanent, etc.) or moveable (e.g., removable, releasable, etc.). Such joining may be achieved with the two members or the two members and any additional intermediate members being integrally formed as a single unitary body with one another or with the two members or the two members and any additional intermediate members being attached to one another.

References herein to the positions of elements (e.g., “top,” “bottom,” “above,” “below,” “between,” etc.) are merely used to describe the orientation of various elements in the figures. It should be noted that the orientation of various elements may differ according to other exemplary embodiments, and that such variations are intended to be encompassed by the present disclosure.

Also, the term “or” is used in its inclusive sense (and not in its exclusive sense) so that when used, for example, to connect a list of elements, the term “or” means one, some, or all of the elements in the list. Conjunctive language such as the phrase “at least one of X, Y, and Z,” unless specifically stated otherwise, is otherwise understood with the context as used in general to convey that an item, term, etc. may be either X, Y, Z, X and Y, X and Z, Y and Z, or X, Y, and Z (i.e., any combination of X, Y, and Z). Thus, such conjunctive language is not generally intended to imply that certain embodiments require at least one of X, at least one of Y, and at least one of Z to each be present, unless otherwise indicated.

It is important to note that the construction and arrangement of the systems as shown in the exemplary embodiments is illustrative only. Although only a few embodiments of the present disclosure have been described in detail, those skilled in the art who review this disclosure will readily appreciate that many modifications are possible (e.g., variations in sizes, dimensions, structures, shapes and proportions of the various elements, values of parameters, mounting arrangements, use of materials, colors, orientations, etc.) without materially departing from the novel teachings and advantages of the subject matter recited. For example, elements shown as integrally formed may be constructed of multiple parts or elements. It should be noted that the elements and/or assemblies of the components described herein may be constructed from any of a wide variety of materials that provide sufficient strength or durability, in any of a wide variety of colors, textures, and combinations. Accordingly, all such modifications are intended to be included within the scope of the present inventions. Other substitutions, modifications, changes, and omissions may be made in the design, operating conditions, and arrangement of the preferred and other exemplary embodiments without departing from scope of the present disclosure or from the spirit of the appended claims.

The invention claimed is:

1. An assembly, comprising:
 - a track with a first magnet on the track, wherein the first magnet comprises a face, wherein the first magnet is configured to rotate about an axis on the track;
 - a second magnet having a face, wherein the face of the second magnet is an opposite polarity to a polarity of the face of the first magnet, wherein the second magnet is positioned such that the face of the second magnet is configured to repel the face of the first magnet; and
 - a device connected to the track and configured to convert rotation of the first magnet on the track into power.
2. The assembly of claim 1, wherein the track further comprises a plurality of magnets in addition to the first magnet, wherein each of the plurality of magnets and the first magnet are equally spaced around a perimeter of the track.

3. The assembly of claim 1, wherein the second magnet comprises a plurality of stacked magnets.

4. The assembly of claim 1, wherein the second magnet is in the shape of a cone, a pyramid, a hemisphere, a conical frustum, or a cylinder.

5. The assembly of claim 1, further comprising:

a support member,

wherein the second magnet is positioned on an outer surface of the support member,

wherein the support member in the shape of a cone, a pyramid, a hemisphere, a conical frustum, or a cylinder.

6. The assembly of claim 1, wherein the first magnet is triangular in shape and the face of the first magnet is at an angle with respect to the axis, and

wherein a side of the first magnet opposite the face is perpendicular to the axis.

7. The assembly of claim 1, further comprising at least one support member extending between the track and the second magnet.

8. The assembly of claim 1, further comprising a housing enclosing the track and the second magnet,

wherein the housing is configured to maintain a vacuum.

9. The assembly of claim 1, wherein the device comprises an electromagnetic device,

wherein the electromagnetic device comprises a rotor and a stator.

10. The assembly of claim 1, further comprising a shaft extending from the device,

wherein the shaft extends along the axis.

11. The assembly of claim 10, further comprising a gear set positioned between the device and the shaft,

wherein the gear set is configured to increase or decrease a rotational speed of the device according to one or more different gear ratios.

12. The assembly of claim 1, wherein at least one of the first magnet or the second magnet comprises an electromagnet.

13. The assembly of claim 12, wherein the electromagnet is configured to receive power from the device.

14. The assembly of claim 1, wherein the first magnet comprises an electromagnet, wherein the track comprises a conductive material,

wherein the conductive material is configured to conduct electricity to the electromagnet.

15. The assembly of claim 1, wherein the track further comprises an upper track and a lower track,

wherein the first magnet is positioned between the upper track and the lower track.

16. The assembly of claim 15, wherein the lower track has a smaller radius than a radius of the upper track.

17. The assembly of claim 1, wherein the second magnet comprises a conical end portion,

wherein the face of the second magnet is disposed at a first angle,

wherein the face of the first magnet is disposed at a second angle.

18. The assembly of claim 17, wherein the first angle and the second angle are the same.

19. The assembly of claim 18, wherein each of the first magnet and the second magnet comprises an electromagnet.

20. The assembly of claim 1, wherein each of the first magnet and the second magnet comprises an electromagnet.