

[54] **MANUALLY OPERATED SAMPLE CHANGING ELEVATOR AND LIGHT SEALING MECHANISM FOR SCINTILLATION COUNTERS AND THE LIKE**

[75] Inventor: Dale D. Robinson, Placentia, Calif.
[73] Assignee: Beckman Instruments, Inc.
[22] Filed: Oct. 28, 1970
[21] Appl. No.: 84,591

[52] U.S. Cl.250/106 SC, 74/25, 74/53, 250/71.5 R
[51] Int. Cl.G01t 1/20
[58] Field of Search250/106 SC, 71.5 R; 74/25, 74/53

[56] **References Cited**

OTHER PUBLICATIONS

Soderholm, L.; Design News; Aug. 1961; "Elevator & Index Mechanism Handling Samples in Radiation Detector"

Primary Examiner—Morton J. Frome
Attorney—Paul R. Harder and Robert J. Steinmeyer

[57] **ABSTRACT**

A sample changing and light sealing mechanism is illustrated and described for moving a sample from one vertical plane to another into a counting chamber while maintaining the light integrity within the chamber. Upon movement of the control arm toward a loading position, a cam on said control arm rotates an actuator wheel and arm to raise the elevator table from a counting position to within an elevator passageway and make a light tight seal at the chamber end of the passageway. The actuator wheel is stopped during further movement of the control arm which then opens an outer shutter over the passageway. The actuator wheel is then again rotated to raise the elevator still further so that the sample may be removed and replaced. Movement in the opposite direction reverses the sequence such that the chamber is at all times sealed against ambient light.

10 Claims, 4 Drawing Figures

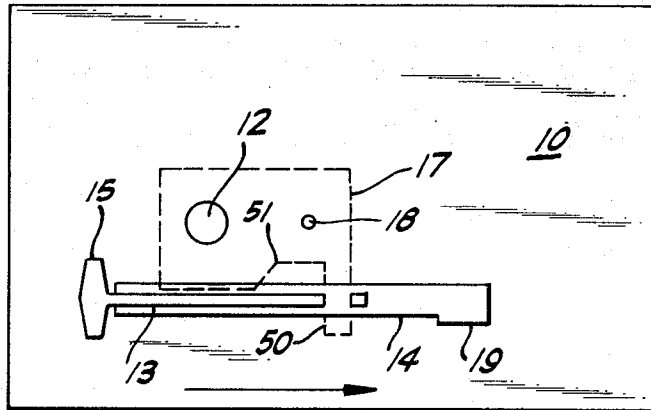

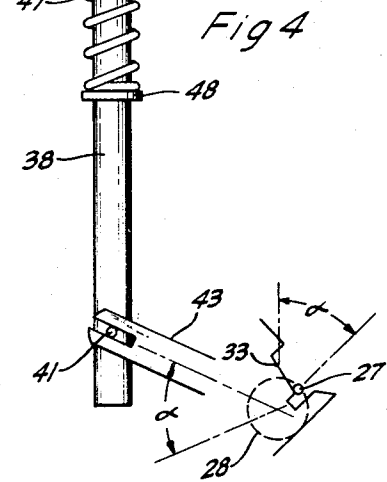
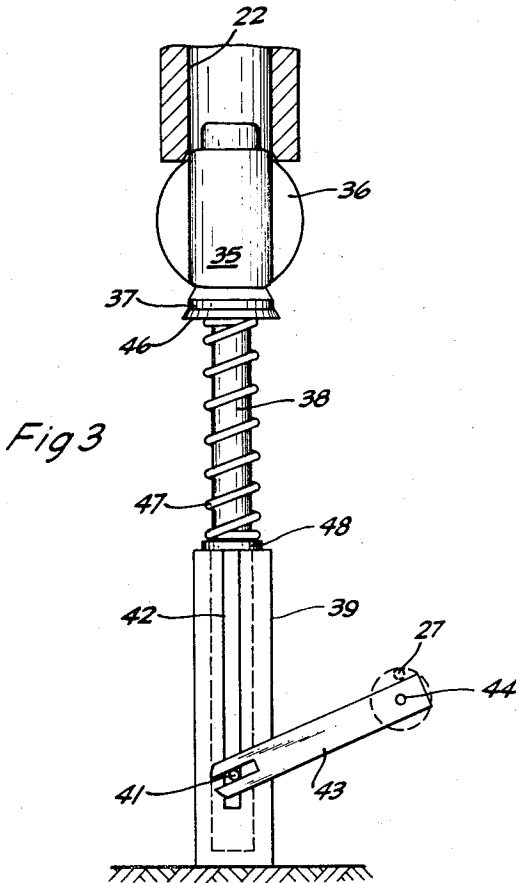
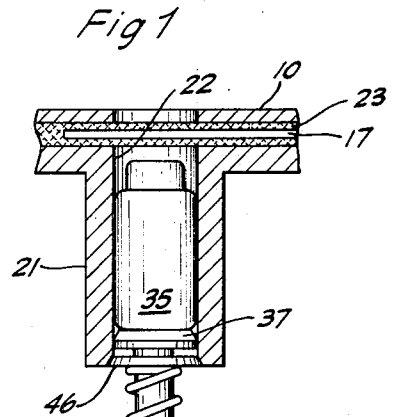
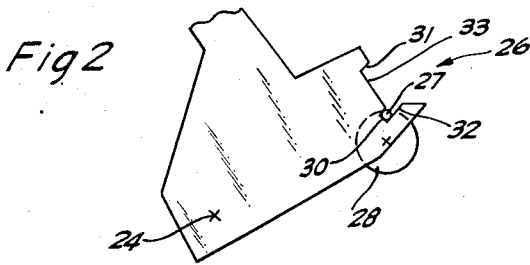
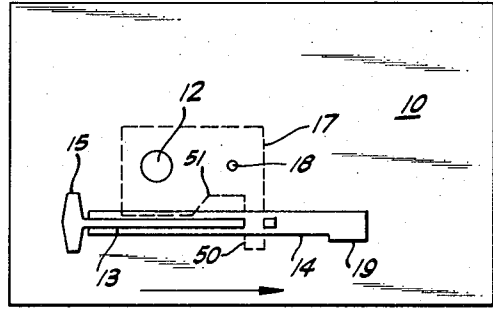
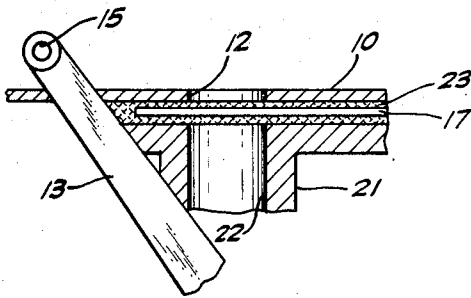

INVENTOR.
DALE D. ROBINSON

MANUALLY OPERATED SAMPLE CHANGING ELEVATOR AND LIGHT SEALING MECHANISM FOR SCINTILLATION COUNTERS AND THE LIKE

This invention relates to a sample conveying elevator and light sealing mechanism for moving a sample vial from one vertical plane to another to position the sample in a counting chamber without exposing the chamber to ambient light.

In the field of liquid scintillation counting it is common practice to place a radioactive sample in a sample vial together with a scintillating cocktail and place the sample vial in a counting chamber where the photons emitted from the scintillating cocktail as a result of the particles emitted by the radioactive sample may be counted. It is common practice to utilize extremely sensitive high voltage photomultiplier tubes for counting the light scintillations emanating therefrom. Due to the high sensitivity of these photomultiplier tubes when operated at high voltages it is necessary to exclude ambient light therefrom at all times to avoid damage to the photomultiplier tube.

Various sample changing and light sealing mechanisms, both manual and automatic, have been utilized in the prior art. The principal object of this invention is to provide a simple, low cost, yet reliable sample changing elevator and light sealing mechanism for moving a sample from one vertical plane to another without exposing the second vertical plane to light from the exterior and which is manually actuated.

Other objects and many of the attendant advantages of this invention will become more readily apparent to those skilled in the art to which this invention pertains by reference to the following description when read in connection with the accompanying drawings in which like parts are designated with like numbers throughout the several views thereof and in which:

FIG. 1 is a plan view of the top exterior of a liquid scintillation counter illustrating the control arm, the sample well and the shutter;

FIG. 2 is a partial cross section illustrating the upper portion of the elevator passageway and the outer light shutter and also illustrating a plan view of the control arm and its cam surfaces in relation to the actuator wheel; and

FIGS. 3 and 4 illustrate the details of the elevator mechanism in two different positions with only the cam portion of the control arm illustrated for simplicity.

Referring now to FIG. 1 there is illustrated a liquid scintillation counter 10 having an aperture or sample well 12 therein for receiving the sample vial for lowering into the interior of the counter for counting. It should be understood that, as is common practice in liquid scintillation counters, aperture 12 affords an opening through an elevator passageway hereinafter described in more detail, into a counting chamber which is contained within the instrument and which is sealed against the entry of all ambient light. The only access into the chamber is through aperture 12 and the elevator passageway. The control arm 13 extends through slot 14 in the top outer surface of the counter and is illustrated in the closed or counting position. Control arm 13 is provided with a handle 15 which by moving in a first direction indicated by the arrow, pivots about a fixed point as described in more detail to raise the elevator shaft and table into the bottom of the elevator passageway, seal the bottom of the passageway

against ambient light, open shutter 17 and further raise the sample vial so that it may be removed from the elevator passageway. Shutter 17 is pivotably mounted by a removable pivot pin 18. Detent 19 is provided in slot 14 to lock the control arm in the open or sample receiving position.

Referring now to FIG. 2 there is illustrated in the background a sectional view of the upper portion of the elevator passageway to show the light sealing detail of shutter 17 and the control arm in front plan view in the foreground. The shutter 17 is secured between the outer panel of the counter 10 and the upper end of housing 21 which forms the elevator passageway 22. Felt packing 23 is placed completely around the shutter 17 to prevent light from leaking around it into the passageway 22. Packing 23 does not, of course, block the opening between aperture 12 and passageway 22.

Control arm 13 is mounted for pivotal movement about the axis 24 and contains a cam generally indicated at 26 cooperating with the bearing 27 mounted upon actuator wheel 28. The control arm cam 26 consists of a first working surface 30, a second working surface 31, a third working surface 32 and a nonworking surface 33. The control arm 13 and actuator wheel 28 are illustrated in FIG. 2 in the counting position, i.e. with the control arm moved in the extreme direction opposite the direction of the arrow in FIG. 1.

Referring now to FIG. 3 there is illustrated a sample counting vial 35 within the counting chamber and positioned in front of the face of photomultiplier tube 36, it being understood that it is common practice to utilize two diametrically opposed photomultiplier tubes for the purpose of counting. The vial 35 is large enough such that in the counting position it slightly extends within the elevator passageway 22 to provide vertical stability. Sample vial 35 sets atop the elevator table 37 connected to elevator shaft 38 which extends down into and slides within the elevator shaft housing 39 which provides vertical stability for the elevator. A pin 41 is secured within the lower end of the elevator shaft 38 and extends through the slot 42 provided within the elevator shaft housing 39. Pin 41 is engaged by the bifurcated end of actuator arm 43 which is mounted on shaft 44.

Shaft 44 passes through a light tight bearing in the counting chamber wall, actuator wheel 28 being secured to shaft 44 exteriorly of the counting chamber. Actuator wheel 28 and bearing 27 are illustrated in phantom to indicate their relative positions to the actuator arm when the control arm is in the counting position as illustrated in FIGS. 1 and 2. It will be seen that as the actuator wheel is rotated in a clockwise direction, actuator arm also rotates in a clockwise direction imparting vertical movement to the elevator shaft and table to raise the sample vial. A light seal 46 is slidably mounted on elevator shaft 38 and is held against the bottom of the elevator table 37 by spring 47. A key 48 is secured to the elevator shaft 38 to secure spring 47 and may also provide a convenient lower stop for the elevator mechanism when vial 35 is in the proper position for counting. Of course, other stop means may be conveniently provided.

Returning briefly to FIG. 2, it will be seen that as control arm 13 is moved to the right corresponding to the direction of the arrow in FIG. 1, working surface 30

of the control arm cam 26 bears against the bearing 27 rotating actuator wheel 28 until nonworking surface 33 is engaged and tangential to bearing 27. Actuator wheel 28 is thus rotated through a predetermined angle α as illustrated in FIG. 4 where only the outline of the cam surface of control arm 13 and the bifurcated end of actuator arm 43 are illustrated for the sake of simplicity.

Actuator arm 43 has likewise been rotated through a like angle α imparting vertical movement to the elevator shaft 38. The condition of the elevator upon initial engagement of bearing 27 with the nonworking surface 33 is illustrated in FIG. 4. As illustrated, the sample vial 35 is completely contained within the elevator passageway 22. Slightly before bearing 27 leaves working surface 30 of cam 26 light seal 46 comes into engagement with the lower end of the elevator passageway and is firmly held in place through additional rising of the elevator shaft and compression of spring 47, it being understood that seal 46 forms a light tight seal not only with the housing 21 at the lower end of the passageway but also with elevator shaft 38. Shutter 17 has not yet been actuated and as bearing 27 moves onto nonworking surface 33 the passageway 22 is sealed against all light at both ends.

Nonworking surface 33 is formed as a constant radius from the pivot point 24 of control arm 13. Thus, further movement of the control arm in the same direction imparts no rotational movement to actuator 28 and the elevator assembly remains stationary and the counting chamber end of the passageway 22 sealed against ambient light.

Referring again to FIG. 1 while the bearing 27 is on the nonworking surface 33 of the control arm cam, further movement of the control arm 13 in the direction of the arrow brings the control arm into engagement with the projecting portion 50 of shutter 17 and pivots shutter 17 about pivot pin 18 to open the shutter. As soon as the shutter has cleared the passageway working surface 31 of the control arm cam 26 comes into engagement with bearing 27 and further movement of the control arm in the direction of the arrow illustrated in FIG. 1 imparts further rotational movement to actuator wheel 28 and actuator arm 43 thereby raising the elevator mechanism within the passageway. This rotational movement continues until the vial 35 projects above the outer surface of the counter 10 where it may be grasped, removed and replaced with another sample vial. Detent 19 is provided and control arm 13 is flexible enough to be moved out of the slot 14 into the detent 19 and is then held because of the compression of spring 47, the weight of the control arm 43 and elevator mechanism which tends to rotate the actuator wheel 28 in the counterclockwise direction.

After a new sample vial has been inserted the control handle is moved in the opposite direction and due to the compression of spring 47 and the weight of the elevator assembly actuator wheel 28 is rotated in a counterclockwise direction until the vial is fully within the elevator passageway 22. At this point the nonworking surface again holds the actuator wheel stationary while further movement of the control arm toward the counting position brings the control arm into engagement with the cam or edge 51 of the shutter

which was rotated into the path of movement of the control arm when the shutter was opened thus rotating the shutter back to its closed position. The passageway is now sealed against ambient light at the outer surface and further movement of the control arm in the same direction, i.e. toward the counting position, brings the working surface 32 of the control arm cam 26 into engagement with bearing 27 thus continuing the counterclockwise rotation of the actuator wheel 28 and arm 43 to return the system to the counting position as illustrated in FIGS. 2 and 3.

It is noted that the cam surfaces and dimensions are constructed and arranged such that during loading of the counter the lower end of elevator passageway 22 is sealed by light seal 46 until the sample vial is completely within the passageway and shutter 17 has been closed. Upon removing the sample vial the light seal 46 closes at the bottom of the passageway before the shutter 17 at the top is opened.

In some instances it is desirable to make continuous measurements with liquid scintillation counters such that they must be adapted to receive flow cells. To this end the pivot pin 18 of the upper shutter mechanism may be removed and the shutter manually slipped in the direction of the arrow to open the passageway. This of course is done when the high voltage has been removed from the photomultiplier tubes thus resulting in no damage due to the ambient light. The flow cell has light sealing characteristics in combination with the interior of the elevator passageway 22.

There has been illustrated and described a simple and reliable manual mechanism for raising and lowering sample vials into a counting chamber while at all times maintaining the counting chamber sealed to ambient light. The mechanical timing of the system is such that as the control lever is moved in one direction the elevator table is raised until the sample vial is contained completely within the elevator passageway and a light seal made at the lower portion of that passageway. At this point movement of the elevator shaft terminates and continued movement of the control arm in the same direction mechanically opens the upper shutter. Still further movement in the same direction continues raising the elevator shaft until the sample vial is at least partially out of the passageway and may be grasped and removed. After loading the reverse sequence occurs in which the sample vial is lowered into the elevator passageway while maintaining the light seal at the bottom, movement of the elevator shaft is momentarily terminated while the upper shutter is mechanically closed and, after this closure, the elevator shaft continues to lower the sample vial into the counting chamber and into counting position.

While the sample changing elevator and light sealing mechanism has been described in detail in connection with liquid scintillation counters it is obvious that it may be utilized in any type of system where it is desired to move a sample or other item from outside a chamber or container without admitting ambient light into the container. Further, while the outer shutter 17 has been described as pivotally mounted, it is also obvious that by providing two projections similar to projection 50, one on each side of the control arm, the shutter may be slid to open and close the upper end of the elevator passageway rather than pivoted.

Further, while the elevator mechanism and actuator arm have been described as being within the counting chamber it is obvious that the chamber need only include the elevator table and the elevator shaft may extend outside the chamber with an appropriate light tight seal being made around the elevator shaft.

What is claimed is:

1. In a sample changing and light seal mechanism of the type having an elevator shaft and table for lowering a sample through an elevator passageway into a chamber, the light seal sealing said elevator passageway at the entrance to the chamber after said table has entered the passageway and a shutter for sealing the end of said elevator passageway opposite said chamber, the improvement comprising:

- a pivotally mounted, manually operable control arm having cam means actuated by movement thereof; an actuator wheel mounted for rotation adjacent said cam means and rotated thereby;
- an actuator arm mounted for rotation with said actuator wheel and driven thereby, said actuator arm engaging said elevator shaft to raise and lower said shaft upon rotation of said actuator wheel;
- a first working surface on said control arm cam means engaging said actuator wheel and imparting rotational movement to said wheel through a given angle as said control arm is moved in said first direction, said rotational movement imparting sufficient movement to said elevator shaft to raise said elevator table from within a chamber into said elevator passageway and to seal the chamber end of said passageway with said light sealing mechanism;
- a non-working surface on said control arm cam means for preventing further rotational movement of said actuator wheel during further movement of said control arm in said first direction;
- said control arm engaging said shutter to open said shutter during said further movement in said first direction;
- a second working surface on said control arm cam means for engaging said actuator wheel upon still further movement of said control arm in said first direction to raise said elevator shaft further within said passageway;
- said control arm engaging and closing said shutter during movement in the opposite direction to lower said elevator shaft to its original position, said shutter being closed before the light seal at the chamber end of said elevator passageway is broken.

2. The sample changing and light sealing mechanism according to claim 1 further comprising:

- a third working surface on said control arm cam means for engaging said actuator wheel during at least a portion of the movement of said control

arm in said opposite direction to return said actuator wheel to its initial position.

3. The sample changing and light sealing mechanism according to claim 1 wherein said actuator wheel has a bearing mounted on the side thereof, said control arm cam means engaging said bearing to impart rotation to said actuator wheel.

4. The sample changing and light sealing mechanism according to claim 3 wherein said actuator wheel and said actuator arm are mounted on a common rotatable shaft.

5. The sample changing and light sealing mechanism according to claim 4 wherein said elevator shaft includes a laterally projecting pin, said actuator arm having a bifurcated end engaging said pin to impart movement of said shaft along its axis upon rotational movement of said actuator arm.

6. The sample changing and light sealing mechanism according to claim 5 wherein said actuator arm is positioned such that the mass of said arm and said elevator shaft and table tend to rotate said arm and said actuator wheel to return said elevator table into said chamber and means adjacent said control arm to lock said control arm at its extreme position of movement in said first direction.

7. The sample changing and light sealing mechanism according to claim 6 in combination with a liquid scintillation counter having a sample counting chamber and wherein said elevator table, said light sealing mechanism and at least a portion of said elevator shaft are contained within said chamber.

8. The sample changing and light sealing mechanism according to claim 6 in combination with a liquid scintillation counter having a sample counting chamber and wherein said elevator shaft and table, said light sealing mechanism and said actuator control arm are contained within said counting chamber, said control arm and actuator wheel being mounted exteriorly to said chamber and said common shaft extending through a wall forming a portion of said chamber.

9. The sample changing and light sealing mechanism according to claim 7 wherein said shutter is pivotally mounted by a removable pivot pin whereby said shutter may be moved in a direction transverse to the axis of rotation of said shutter.

10. The sample changing and light sealing mechanism according to claim 9 wherein said shutter mechanism is mounted adjacent said control arm and having a first portion extending into the path of movement of said control arm in said first direction whereby said shutter is rotated to open said elevator passageway as said control arm is moved in said first direction, said shutter having a second portion extending into the path of movement of said control arm when said shutter is open to close said shutter when said control arm is moved in the opposite direction.

* * * * *