

(19) World Intellectual Property Organization  
International Bureau



(43) International Publication Date  
14 April 2005 (14.04.2005)

PCT

(10) International Publication Number  
WO 2005/032348 A2

- (51) International Patent Classification<sup>7</sup>: **A61B** [US/US]; 27851 Encanto, Mission Viejo, CA 92692 (US).
- (21) International Application Number: **PCT/US2004/032346** **JOHNSON, Gary, M.** [US/US]; 24662 Canela, Mission Viejo, CA 92692 (US). **BRUSTAD, John, R.** [US/US]; 34056 Formosa Drive, Dana Point, CA 92529 (US).
- (22) International Filing Date: 1 October 2004 (01.10.2004)
- (25) Filing Language: English
- (26) Publication Language: English
- (30) Priority Data: 60/508,390 3 October 2003 (03.10.2003) US
- (71) Applicant (for all designated States except US): **APPLIED MEDICAL RESOURCES CORPORATION** [US/US]; 22782 Avenida Empresa, Rancho Santa Margarita, CA 92688 (US).
- (72) Inventors; and
- (75) Inventors/Applicants (for US only): **KAHLE, Henry** [US/US]; 25 Wrangler Court, Trabuco Canyon, CA 92679 (US). **STROKOSZ, Arkadiusz, A.** [US/US]; 24682 Evening Star Dr., Dana Point, CA 92629 (US). **McGINLEY, Kimball, B.** [US/US]; 25062 Armagosa Drive, Laguna Niguel, CA 92677 (US). **TAYLOR, Scott, V.**
- (74) Agent: **VU, Kenneth, K.**; 22872 Avenida Empresa, Rancho Santa Margarita, CA 92688 (US).
- (81) Designated States (unless otherwise indicated, for every kind of national protection available): AE, AG, AL, AM, AT, AU, AZ, BA, BB, BG, BR, BW, BY, BZ, CA, CH, CN, CO, CR, CU, CZ, DE, DK, DM, DZ, EC, EE, EG, ES, FI, GB, GD, GE, GH, GM, HR, HU, ID, IL, IN, IS, JP, KE, KG, KP, KR, KZ, LC, LK, LR, LS, LT, LU, LV, MA, MD, MG, MK, MN, MW, MX, MZ, NA, NI, NO, NZ, OM, PG, PH, PL, PT, RO, RU, SC, SD, SE, SG, SK, SL, SY, TJ, TM, TN, TR, TT, TZ, UA, UG, US, UZ, VC, VN, YU, ZA, ZM, ZW.
- (84) Designated States (unless otherwise indicated, for every kind of regional protection available): ARIPO (BW, GH, GM, KE, LS, MW, MZ, NA, SD, SL, SZ, TZ, UG, ZM, ZW), Eurasian (AM, AZ, BY, KG, KZ, MD, RU, TJ, TM), European (AT, BE, BG, CH, CY, CZ, DE, DK, EE, ES, FI,

[Continued on next page]

(54) Title: BLADELESS OPTICAL OBTURATOR

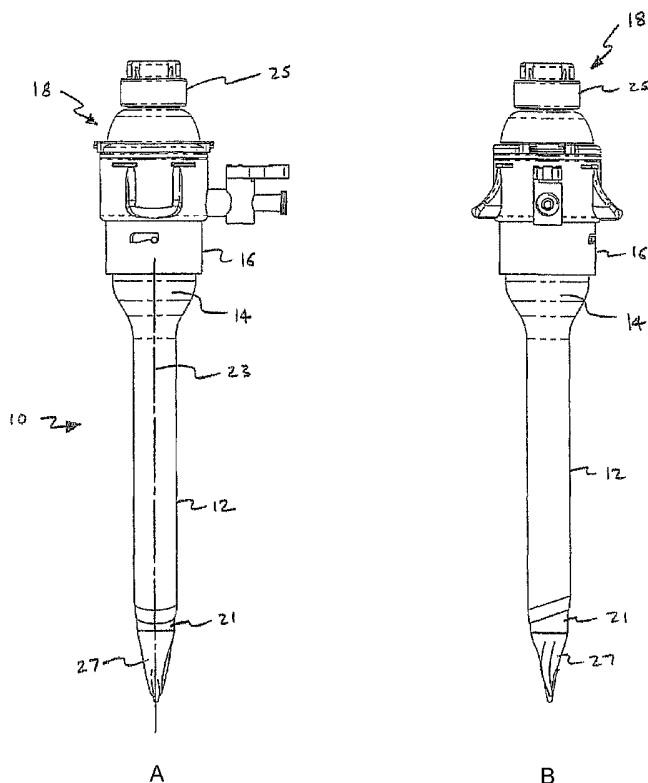

(57) Abstract: The invention is directed to a bladeless trocar obturator to separate or divaricate body tissue during insertion through a body wall. In one aspect, the obturator of the invention comprises a shaft extending along an axis between a proximal end and a distal end; and a bladeless tip disposed at the distal end of the shaft and having a generally tapered configuration with an outer surface, the outer surface extending distally to a blunt point with a pair of side sections having a common shape and being separated by at least one intermediate section, wherein each of the side sections extends from the blunt point radially outwardly with progressive positions proximally along the axis, and the shaft is sized and configured to receive an optical instrument having a distal end to receive an image of the body tissue. With this aspect, the tapered configuration facilitates separation of different layers of the body tissue and provides proper alignment of the tip between the layers. The side sections include a distal portion and a proximal portion, the distal portion of the side sections being twisted radially with respect to the proximal portion of the side sections. The intermediate section includes a distal portion and a proximal portion, the distal portion of the intermediate section being twisted in a first radial direction and the proximal portion of the intermediate section being twisted in a second radial direction opposite the first radial direction.

WO 2005/032348 A2



FR, GB, GR, HU, IE, IT, LU, MC, NL, PL, PT, RO, SE, SI, SK, TR), OAPI (BF, BJ, CF, CG, CI, CM, GA, GN, GQ, GW, ML, MR, NE, SN, TD, TG).

*For two-letter codes and other abbreviations, refer to the "Guidance Notes on Codes and Abbreviations" appearing at the beginning of each regular issue of the PCT Gazette.*

**Published:**

— *without international search report and to be republished upon receipt of that report*

## BLADELESS OPTICAL OBTURATOR

5           This is a continuation-in-part of co-pending U.S. Application No.  
10/489,403, filed on March 11, 2004, which is a 371 of International Application  
No. PCT/US02/06759, filed on March 4, 2002 based on Provisional Application  
Serial No. 60/324,613, filed on September 24, 2001, and entitled "Bladeless  
Obturator," all of which are fully incorporated herein by reference. This  
10 continuation-in-part application further claims priority to provisional application  
Serial No. 60/508,390, filed on October 3, 2003, entitled "Bladeless Optical  
Obturator," which is fully incorporated herein by reference.

## BACKGROUND OF THE INVENTION

15           Field of the Invention

          This invention generally relates to trocar systems including obturators and,  
more specifically, to blunt tip obturators having hollow shafts for insertion of  
20 optical instruments.

### Discussion of the Prior Art

          Trocar systems have been of particular advantage in facilitating less  
invasive surgery across a body wall and within a body cavity. This is particularly  
true in abdominal surgery where trocars have provided a working channel across  
25 the abdominal wall to facilitate the use of instruments within the abdominal cavity.

          The trocar systems of the past typically included a cannula, which  
provides the working channel, and an obturator which is used to place the  
cannula across the abdominal wall. The obturator is inserted into the working

channel of the cannula and then pushed through the abdominal wall with a penetration force of sufficient magnitude resulting in penetration of the abdominal wall. Once the cannula is in place, the obturator can be removed.

Obturers have been developed with an attempt to reduce the penetration force of the abdominal wall. For example, sharp blades, sharp edges and piercing points have typically been used to enable the obturator to cut or pierce its way through the abdominal wall. While the sharp blades, sharp edges and piercing points have facilitated a reduced penetration force, they have also caused larger trocar site defects. These trocar site defects may have to be sutured closed resulting in increased operating room costs and procedural time. Moreover, once the abdominal wall has been penetrated, the sharp blades, sharp edges and piercing points of the obturator may still cause damage to the vessels and organs that lie within the peritoneal cavity. For example, the blades on the obturators that serve to cut tissue during insertion may also cut vessels or puncture organs that may result in patient injury or surgical complications.

In some cases, shields have been provided with the obturators in order to sense penetration of the abdominal wall and immediately shield the sharp blades, edges or piercing points. These shielding systems are typically complex and require some time to deploy and, as such, many have not been effective in protecting the vessels and organs against the sharp blades, edges or piercing points. Accordingly, there remains a need in the art for an improved bladeless obturator that separates tissue during insertion through a body wall. Moreover, there is a need for a transparent blunt tip obturator having a hollow shaft to

enable insertion of an optical instrument to view the insertion of the obturator through the body wall.

### SUMMARY OF THE INVENTION

5

The invention is directed to a bladeless trocar obturator to separate or divaricate body tissue during insertion through a body wall. The distal tip of the bladeless obturator is constructed of a transparent material to enable visualization of tissue during the insertion of the obturator through the body wall.

10

The bladeless obturator is configured to enable the insertion of a conventional laparoscope which typically includes an imaging element and fiber optic light fibers. During use, the bladeless obturator is first inserted into and through a trocar seal and cannula. A conventional laparoscope is then inserted into the proximal end of the bladeless obturator and advanced to the distal tip of the obturator. An endoscopic video camera is attached to the proximal end of the laparoscope and the bladeless trocar system is then axially advanced by the surgeon through the body wall, the surgeon can visually observe the tissue as it is being separated via a video monitor that is connected to the endoscopic video camera.

15

20

In one aspect, the obturator of the invention comprises a shaft extending along an axis between a proximal end and a distal end; and a bladeless tip disposed at the distal end of the shaft and having a generally tapered configuration with an outer surface, the outer surface extending distally to a blunt point with a pair of side sections having a common shape and being separated by at least one intermediate section, wherein each of the side sections extends

25

from the blunt point radially outwardly with progressive positions proximally along the axis, and the shaft is sized and configured to receive an optical instrument having a distal end to receive an image of the body tissue. With this aspect, the tapered configuration facilitates separation or spreading of different layers of the body tissue and provides proper alignment of the tip between the layers. The side sections include a distal portion and a proximal portion, the distal portion of the side sections being twisted radially with respect to the proximal portion of the side sections. The intermediate section includes a distal portion and a proximal portion, the distal portion of the intermediate section being twisted in a first radial direction and the proximal portion of the intermediate section being twisted in a second radial direction opposite the first radial direction.

The bladeless tip can be formed from a transparent material or a translucent material. The bladeless tip can be formed from a plastic material or a glass material. The plastic material can be at least one of polycarbonate, polyphenylsulfone, polyetherimide, acrylic, and polyvinyl chloride. The bladeless obturator can be constructed such that at least one of the shaft and the tip is formed from a reusable or a disposable material. The reusable material can be a metallic material or an autoclavable polymer. The bladeless tip can be generally hollow or substantially solid to receive the distal end of the optical instrument. The bladeless tip can also be solid. The bladeless tip can further comprise at least one portion that is marked differently from the rest of the tip to serve as an indicator, for example, of depth as the tip is being inserted into the body tissue. The bladeless tip can be shaped and configured to receive the distal end of the

optical instrument having an angled or non-angled lens. The bladeless tip can further comprise a ledge to provide proper positioning of the distal end of the optical instrument having an angled or non-angled lens. The bladeless tip can further comprise a bulbous section to accommodate the distal end of the angled  
5 lens optical instrument. The bladeless tip can be further coated or formed from a soft elastomeric material. The shaft and the tip can be connected together by adhesive bonding, ultrasonic welding, snap-fitting, with a shrink tube, or by overmolding the tip over the shaft. The bladeless tip can further comprise a cutout section to provide the distal end of the optical instrument with direct vision  
10 of the body tissue.

In another aspect of the invention, the bladeless obturator further comprises a lock disposed at the proximal end of the shaft to frictionally lock the optical instrument in an axial position in the shaft. The lock operates to prevent the optical instrument from moving axially relative to the shaft while allowing the  
15 optical instrument to rotate freely about the shaft. The lock can be constructed from a plastic material including polycarbonate. The lock can be a multi-finger collet having an inner diameter smaller than an outer diameter of the optical instrument wherein the fingers of the collet spread open during insertion of the optical instrument providing frictional engagement with the outer diameter of the  
20 optical instrument. The lock can further comprise a camming member to constrict the optical instrument in the axial position relative to the shaft. The camming member may be a horizontal or vertical camming member. In another aspect, the lock can further comprise a locking collar to rotationally lock the

optical instrument. In yet another aspect, the lock can further comprise a locking nut and thread that frictionally engage the optical instrument in the axial position relative to the shaft, or an elastomeric element that facilitates frictional engagement with the optical instrument in the axial position relative to the shaft.

5 In another aspect of the invention, the bladeless obturator further comprises a cap disposed at the proximal end of the shaft. The cap may further comprise a handle.

In yet another aspect of the invention, a surgical obturator adapted to separate body tissue is disclosed comprising a shaft extending along an axis  
10 between a proximal end and a distal end; and a bladeless tip disposed at the distal end of the shaft having a tapered surface forming proximally into an outer surface, the outer surface including a pair of generally opposed sections, wherein the outer surface has a generally geometric shape in progressive radial cross-sections from a distal cross-section to a proximal cross-section, wherein the pair  
15 of generally opposed sections of the outer surface appears as a pair of lines in each of the progressive radial cross-sections, wherein at least one of the pair of lines becomes more arcuate in the progressive radial cross-sections, and wherein the shaft is sized and configured to receive an optical instrument having a distal end to receive an image of the body tissue. With this aspect, the area of  
20 the geometric shape increases along the progressive radial cross-sections.

In another aspect of the invention, a surgical obturator adapted to separate body tissue is disclosed comprising a shaft having a proximal end and a distal end; and a transparent bladeless tip disposed at the distal end of the shaft



having a tapered surface forming proximally into an outer surface, the outer surface extending distally to a blunt point, wherein the shaft is sized and configured to receive an optical instrument having a distal end to receive an image of the body tissue.

5            In yet another aspect of the invention, an optical separator adapted to receive an image of a body tissue and to separate the body tissue is disclosed comprising an optical instrument having a proximal end and a distal end; and a bladeless tip removably attached at the distal end of the optical instrument and having a generally tapered configuration with an outer surface, the outer surface  
10 extending distally to a blunt point.

These and other features of the invention will become more apparent with a discussion of the various embodiments in reference to the associated drawings.

## 15    DESCRIPTION OF THE DRAWINGS

The accompanying drawings, which are included in and constitute a part of this specification, illustrate the embodiments of the invention and, together with the description, explain the features and principles of the invention. In the drawings:

20            FIGS. 1A and 1B illustrate side views of a trocar system including a cannula with associated valve housing, and an obturator with a blunt tip extending through the working channel of the cannula to facilitate placement across the abdominal wall;

FIG. 2 is a side elevation view of the blunt tip of the obturator of the invention;

FIG. 3 is a side elevation view of the blunt tip taken along line 3-3 of FIG. 2;

5 FIG. 4 is an end view taken along line 4-4 of FIG. 2;

FIG. 5 is a radial cross-section view taken along line 5-5 of FIG. 2;

FIG. 6 is a radial cross-section view taken along line 6-6 of FIG. 2;

FIG. 7 is a radial cross-section view taken along line 7-7 of FIG. 2;

FIG. 8 is a radial cross-section view taken along line 8-8 of FIG. 2;

10 FIG. 9 is a radial cross-section view taken along line 9-9 of FIG. 2;

FIG. 10 is a schematic view illustrating each of the FIGS. 4-9 superimposed to facilitate an understanding of the blunt tip and its twisted configuration;

FIG. 11 illustrates a side view of a bladeless obturator of the invention having a tip formed as a blunt tapered shape;

FIG. 12 illustrates a side view of a bladeless obturator of the invention having a tip formed as a pyramidal shape;

FIG. 13 illustrates a side view of a bladeless obturator of the invention having a fully radiused tip;

20 FIGS. 14 and 15 illustrate a side view and a cross-section view, respectively, of the trocar system of FIGS. 1A and 1B and further illustrating the insertion of a laparoscope;

FIG. 16 illustrates a side view of a bladeless obturator of the invention having a bulbous tip;

FIG. 17 illustrates a side view of a bladeless obturator of the invention having a tip with a cutout section;

5 FIG. 18 illustrates a side view of a bladeless obturator of the invention having a shaft with a cutout section;

FIG. 19 illustrates a side view of a bladeless obturator of the invention and a cover for the cutout section of the shaft of FIG. 18;

10 FIGS. 20 and 21 illustrate side views of a bladeless obturator of the invention having a laparoscope lock;

FIGS. 22 and 23 illustrate side views of a bladeless obturator of the invention including a cap with pistol-grip handle;

FIGS. 24 and 25 illustrate the locking mechanism between the bladeless obturator and the trocar seal of the invention;

15 FIGS. 26 and 27 illustrate the release mechanism between the bladeless obturator and the trocar seal of the invention;

FIG. 28 illustrates a top view of a laparoscope lock of the invention comprising a multiple-finger collet;

20 FIG. 29 illustrates an optical instrument having a transparent bladeless tip of the invention;

FIGS. 30 and 31 illustrate a top view and a side view, respectively, of a laparoscope lock of the invention comprising a camming member;

FIGS. 32 and 33 illustrate a top view and a side view, respectively, of a laparoscope lock of the invention comprising a clamping member;

FIGS. 34 and 35 illustrate a top view and a side view, respectively, of a laparoscope lock of the invention comprising a locking collar; and

5 FIGS. 36 and 37 illustrate a top view and a side view, respectively, of a laparoscope lock of the invention comprising a locking nut and thread.

### DESCRIPTION OF THE INVENTION

A trocar system is illustrated in FIG. 1 and is designated by reference  
10 numeral 10. This system includes a cannula 12, defining a working channel 14,  
and a valve housing 16. The system 10 also includes an obturator 18 having a  
shaft 21 extending along an axis 23. A handle 25 is disposed at a proximal end  
of the shaft 21 while a blunt tip 27 is disposed at a distal end of the shaft 21. The  
shaft 21 of the obturator 18 is sized and configured for disposition within the  
15 working channel 14 of the cannula 12. With this disposition, the obturator 18 can  
be placed across a body wall such as the abdominal wall to provide the cannula  
12 with access across the wall and into a body cavity, such as the peritoneal or  
abdominal cavity. The blunt tip 27 serves to direct the obturator 18 through the  
abdominal wall and the peritoneum, and can be removed with the obturator 18  
20 once the cannula 12 is operatively disposed with the working channel 14  
extending into the abdominal cavity. The diameter of the shaft 21 can range from  
about 3 mm to about 20 mm and is designed to fit within a trocar seal and the  
cannula 12.

In accordance with the present invention, the tip 27 is provided with a blunt tip configuration. The blunt tip 27 of the invention takes into account the anatomical configuration of the abdominal wall with an improved structural design and method of insertion. To fully appreciate these aspects of the invention, it is helpful to initially discuss the anatomy associated with the abdominal wall. The abdominal wall typically includes a skin layer and a series of muscle layers, in addition to fat and fascia. The muscle layers are each defined by muscle fibers that extend generally parallel to each other in a direction that is different for each of the layers. For example, fibers of a first muscle layer and a second muscle layer may extend in directions that are generally 90 degrees off of each other.

Having noted the directional nature of the muscle fibers, it can be appreciated that such a structure may be separated or divaricated by an obturator having a blunt tip. The blunt tip may also include a twisted rectangular configuration to facilitate movement between the muscle fibers and layers. That is, the blunt tip is capable of being moved generally parallel to and between the fibers associated with a particular muscle layer.

As described earlier, the fibers of the muscle layers may be oriented at different angles to each other such that proper alignment of the tip 27 for separation of one layer may not necessarily result in proper alignment for separation of the next layer. For at least this reason, the obturator 18 has a blunt tip 27 to direct the obturator 18 through the different layers and a rectangular configuration that is twisted slightly so that separation of a first layer begins to

rotate the distal end of the blunt tip 27 into proper orientation for separation of the next layer.

The twisted configuration of the blunt tip 27 also causes the blunt tip 27 to function, for example, with the mechanical advantage of a screw thread. With this configuration, an exemplary method of placement requires that the user grip the handle 25 of the obturator 18 and twist it about the axis 23. This twisting motion in combination with the screw configuration of the blunt tip 27 converts radial movement into forward movement along the axis 23. Thus, the user applies both a forwardly directed force as well as a radial force to move the trocar system 10 in a forward direction.

The twisted configuration of the blunt tip 27 is most apparent in the side elevation views of FIGS. 2 and 3. In this embodiment, the blunt tip 27 comprises generally of eight surfaces: two opposing surfaces 50 and 52, separated by two side surfaces 54 and 56, two end surfaces 58 and 59, a generally tapered surface 60 formed in surfaces 50 and 52 around axis 23 and extending beyond end surfaces 58 and 59, and a blunt surface 62.

The surfaces 50 and 52, side surfaces 54 and 56, and tapered surface 60 generally define the cross-section of the blunt tip 27 from blunt surface 62 to proximal end 61. This configuration can best be appreciated with reference to the cross-section views of FIGS. 4-9. In FIG. 4, the distal end of the blunt tip 27 is shown with a circle 64 having the smallest circular area and a rectangle 63 having the greatest length-to-width ratio. The rectangle 63 has a twisted, S-shaped configuration at end surfaces 58 and 59.

As views are taken along progressive proximal cross-sections, it can be seen that the circle 64 becomes larger and the rectangle 63 becomes less twisted, and the width increases relative to the length of the rectangle 63. The spiral nature of the blunt tip 27 is also apparent as the circle 64 and rectangle 63 move counterclockwise around the axis 23. This is perhaps best appreciated in a comparison of the circle 64 and the rectangle 63 in FIG. 6 relative to that in FIG. 5. With progressive proximal positions, the circle 64 begins to expand with increasing circular area and the rectangle 63 begins to widen with a reduction in the ratio of length to width. The long sides of the rectangle 63 also tend to become more arcuate as they approach a more rounded configuration most apparent in FIGS. 8 and 9. That is, the circle 64 and the rounded rectangle 63 become more circular with progressive proximal positions. Furthermore, the circle 64 expands at a lesser rate than the rectangle 63, which eventually absorbs the circle 64 as shown in FIGS. 8 and 9. In these figures, it will also be apparent that the rotation of the rectangle 63 reaches a most counterclockwise position and then begins to move clockwise. This is best illustrated in FIGS. 7-9. This back and forth rotation results from the configuration of the side surfaces 54 and 56, which in general are U-shaped as best illustrated in FIGS. 2 and 3.

The ratio of the length to width of the rectangle 63 is dependent on the configuration of the side surfaces 54 and 56, which define the short sides of the rectangle 63 as well as the configuration of the surfaces 50 and 52, which define the long sides of the rectangle 63. Again with reference to FIGS. 2 and 3, it can be seen that the side surfaces 54 and 56 are most narrow at the end surfaces 58

and 59. As the side surfaces 54 and 56 extend proximally, they reach a maximum width near the point of the most counterclockwise rotation, shown generally in FIG. 8, and then reduce in width as they approach the proximal end 61. Along this same distal to proximal path, the surfaces 50 and 52 transition  
5 from a generally flat configuration at the end surfaces 58 and 59 to a generally rounded configuration at the proximal end 61.

In the progressive views of FIGS. 5-7, the circle 64 is further designated with a lower case letter a, b or c, respectively; similarly, the rectangle 63 is further designated with a lower case letter a, b, c, d or e, respectively, in FIGS. 5-9. In  
10 FIG. 10, the circles 64, 64a-64c and the rectangles 63, 63a-63e are superimposed on the axis 23 to show their relative sizes, shapes and angular orientations.

With a generally tapered configuration at the distal end and a rectangular configuration at a distal portion of the tip, the tip 27 appears much like a flathead  
15 screwdriver having a blunt tip. More particularly, the tip 27 includes a tapered structure extending outward from the end surfaces 58 and 59 that serves to direct the obturator 18 through the tissue fibers.

In one aspect, the lengths of the end surfaces 58 and 59 may be aligned parallel with the fibers of each muscle layer. A simple back and forth twisting  
20 motion of the blunt tip 27 tends to separate the fibers along natural lines of separation, opening the muscle layer to accept the larger diameter of the cannula 12. Once the first layer is substantially separated, the tapered and twisted configuration of the blunt tip 27 directs and turns the rectangle 63 more into a



parallel alignment with fibers in the next layer. Again, the blunt tip 27 and the twisting or dithering motion facilitates an easy separation of the fibers requiring a significantly reduced insertion force.

The invention facilitates a unique method of separating tissue and can be applied to any object with a blunt tip and generally flat sides. In particular, the device of the invention can be operated by rotating in alternating clockwise and counterclockwise directions while applying a downward force. When rotating in alternating directions, the tissue is moved apart and a larger opening is created for a profile of greater cross-sectional area to follow. This process continues safely as the device enters the peritoneal cavity and moves to its operative position.

When the cannula 12 is ultimately removed, the size of the opening left in the tissue is minimal. Importantly, this opening is left with a small defect that does not require suturing due to a dilating effect caused by the mere separation of fibers. Since there are no sharp blades, sharp edges or piercing points to cut tissue fibers, the healing process is shortened. It is appreciated that in other aspects of the invention, the tip of the bladeless obturator 18 can be formed as a generally tapered shape 27a with a blunt distal end as illustrated in FIG. 11, as a pyramidal shape 27b with a blunt distal end and blunt edges as illustrated in FIG. 12, and as a fully radiused tip 27c for insertion through flaccid tissue or an existing body orifice such as the urethra as illustrated in FIG. 13.

The blunt tip 27 can be formed from a translucent or a transparent material. The blunt tip 27 can be formed from a plastic material or a glass

material. In one aspect, the shaft 21 and the tip 27 are formed from a transparent polycarbonate material.

Referring to FIGS. 14 and 15, the bladeless obturator 18 of the invention is designed to accommodate the insertion of a conventional laparoscope 30. In particular, the shaft 21 of the bladeless obturator 18 is hollow to allow for the insertion of the laparoscope 30 at an opening 32. The shaft 21 is sized and configured to allow the laparoscope 30 to slide within proximity of the tip 27 thus providing a viewing area through the tip 27. An endoscopic video camera (not shown) is typically connected to the laparoscope 30 and this combination is connected to a video monitor. By enabling the positioning of the conventional laparoscope 30 within the tip 27 of the bladeless obturator 18, it is possible to visually observe body tissue as it is being separated by the trocar system 10. Visualization of body tissue as it is being separated by the trocar system 10 allows a surgeon to monitor the advancement of the trocar system 10 and to avoid traumatizing vessels or organs. For example, during a laparoscopic cholecystectomy, a trocar is usually placed through the umbilicus of the patient. The placement of this trocar is typically performed in a blind fashion in that the surgeon cannot see where the tip of the trocar is as it is advanced through the abdominal wall and into the abdominal cavity of the patient. This results in a high degree of risk that the trocar may be inadvertently advanced too far into the abdomen of the patient resulting in trauma to vital organs and/or vessels. By providing a trocar system with visualization properties, this risk is diminished as

the surgeon is better able to determine when the trocar has traversed the abdominal wall.

It is appreciated that the tip 27 may be generally hollow or it may be substantially solid to receive the distal end of the laparoscope 30. In another aspect, the tip 27 may be a solid tip. The tip 27 may further comprise at least one portion that is marked differently from the rest of the tip to serve as an indicator, for example, of depth as the tip 27 is being inserted into the body tissue. The at least one portion may be opaque or marked with a different color from the rest of the tip 27.

The shaft 21 and the tip 27 of the bladeless obturator 18 can accommodate a laparoscope with a non-angled lens, also known as a 0° laparoscope. The shaft 21 and the tip 27 can also accommodate a laparoscope with an angled lens such as a 30° laparoscope. The tip 27 is designed such that when either a 0° laparoscope or a 30° laparoscope is inserted therein, the lens of the laparoscope extends beyond a distal edge 36 of the cannula 12 thereby providing a clear and unobstructed view through the tip 27. The tip 27 further includes a ledge 39 that properly engages either the 0° laparoscope or the 30° laparoscope.

It should be noted that conventional trocars with visualization properties typically require a 0° laparoscope for insertion of the trocars and a 30° laparoscope for viewing anatomical structures during the remainder of the laparoscopic procedure. This requires the operating staff to provide two laparoscopes for the laparoscopic procedure, which increases hospital inventory

costs and surgical preparation costs relating to cleaning and sterilization of the laparoscopes. In addition, because two laparoscopes are required for the laparoscopic procedure, there is additional operating room time required during the surgical procedure to transfer the endoscopic video camera from the 0°  
5 laparoscope to the 30° laparoscope which results in increased operating room costs for the hospital.

The bladeless obturator of the present invention provides a clear unobstructed view of body tissue through either a 0° or a 30° laparoscope, therefore obviating the need for a hospital to carry the additional inventory  
10 required to provide two laparoscopes for each laparoscopic surgical procedure, and obviating the need for a hospital to clean and sterilize a second laparoscope for each laparoscopic surgical procedure, and obviating the need to transfer the endoscopic video equipment from one laparoscope to the other laparoscope during each laparoscopic surgical procedure. Referring to FIG. 16, the shaft 21  
15 may include a tip with a bulbous section 27d to better accommodate the distal end of the angled lens laparoscope. By adding the bulbous section 27d, the distal end of the angled lens laparoscope would be closer to the tip of the obturator thereby improving visualization.

In yet another aspect of the invention, the bladeless obturator can include  
20 integral fiber optic light fiber elements and an integral imaging element within the shaft and the tip of the obturator. The bladeless obturator with integral imaging means can be formed of reusable or disposable materials.

The bladeless obturator 18 can be constructed as a single component or as multiple components such as the shaft 21 and the tip 27. If the obturator 18 is constructed as a single component, then it can be formed from either disposable or reusable materials. If the obturator 18 is constructed as two or more  
5 components, then each component can be formed from either disposable or reusable materials as desired for a particular configuration. In one aspect, the obturator 18 is constructed from a single reusable material such as metal (e.g., stainless steel) or an autoclavable polymer to facilitate re-sterilization. In another aspect, the obturator 18 is formed from a transparent steam sterilizable reusable  
10 plastic material such as polyphenylsulfone or polyetherimide. The blunt tip 27 can also be coated or otherwise constructed from a soft elastomeric material. In such a case, the material can be a solid elastomer or composite elastomer/  
polymer.

It is further appreciated that the shaft 21 can be formed so as to be  
15 partially or fully flexible. With this configuration, the obturator 18 can be inserted through a passageway containing one or more curves of virtually any shape. A partially or fully flexed obturator 18 can then be used with a flexible cannula 12 allowing greater access to an associated body cavity.

The obturator 18 can include a separately molded tip 27 and a molded or  
20 extruded shaft 21 with the two components, as explained above, comprising of the same material or different materials. The tip 27 can then be attached to the shaft 21 by adhesive bonding, ultrasonic welding, snap-fitting, or with a shrink tube. The tip 27 can also be overmolded over the shaft 21 to mechanically lock

the two components together. The tip 27 can be formed from a transparent material such as polycarbonate to enable visualization while the shaft 21 can be formed from either an opaque material or a transparent material. The shaft 21 can also be formed from a metal material.

5 In another aspect, the obturator 18 can include a disposable tip that is releasably attached to a reusable shaft 21. In this aspect, a new tip 27 can be used for each procedure to provide optimal visualization through the tip 27 of the obturator 18 during each procedure.

Referring to FIG. 17, there is shown a shaft 18e in accordance with  
10 another aspect of the invention including a cutout section 100e in the tip portion 27e that enables direct visualization of the body tissue as the tip 27e separates tissue fibers. By providing an obturator with cutout sections, the reflection of light from the laparoscope is minimized and the visibility of the tissue through the laparoscope is improved as compared to a design where visualization occurs  
15 through a plastic or glass window. It is appreciated that the shaft 21e can include a single or a plurality of cutouts 100e in the tip 27e or along the shaft of the obturator.

Referring to FIG. 18, there is shown a shaft 21f in accordance with  
another aspect of the invention having a cutout portion 100f along the axial axis  
20 of the shaft 21f. The shaft 21f has a cross-section of about  $\frac{1}{2}$ -circle to about  $\frac{3}{4}$ -circle and the cutout portion 100f has a cross-section of about  $\frac{1}{2}$ -circle to about  $\frac{1}{4}$ -circle. An advantage of this aspect of the invention is the wall of the shaft 21f

can be a little thicker as a result of the cutout section, which makes injection molding of the shaft easier.

Referring to FIG. 19, there is shown a cover 102f that can be attached over the cutout portion 100f of the  $\frac{1}{2}$ -circle shaft 21f as shown in FIG. 18. In particular, a polycarbonate cover also with a  $\frac{1}{2}$ -circle shaped cross-section can be attached to the shaft to form a tubular cross-section. An advantage of molding the tubular shaft 21f in two pieces is increased manufacturability of the shaft 21f. The cover 102f can be attached to the shaft 21f with an adhesive bond, an ultrasonic weld, a snap-fit, or with a shrink tube.

In another aspect, the obturator can be formed from two clam-shell components each including one-half of the shaft and tip configuration along the axial axis of the obturator. The two components can then be affixed together using an adhesive bond, an ultrasonic weld, an outer shrink tube, or a snap fit.

Referring to FIGS. 20 and 21, another feature of the bladeless obturator 18 of the invention is it is designed to frictionally lock the laparoscope 30 in place using a laparoscope lock 40, which can be formed within the handle 25. More specifically, the laparoscope lock 40 prevents the laparoscope 30 from moving axially relative to the shaft 21 of the obturator 18 during handling within the sterile field and during insertion through a body wall but enables the laparoscope 30 to rotate freely relative to the shaft 21. This rotation of the lock 40 enables the trocar system 10 to be twisted during insertion into and through the abdominal wall while maintaining the laparoscope 30 in a fixed rotational position that provides for a stable viewing image on the video monitor.

The conventional obturators with visualization properties include means for locking the laparoscope in place but these obturators lock the laparoscope both axially and rotationally. A drawback of the conventional devices is the viewing image on the video monitor is unstable if the trocar is twisted during  
5 insertion. More specifically, with prior art obturator laparoscope locks, if the trocar is twisted back and forth in a clockwise and counter-clockwise fashion, the laparoscope also moves clockwise and counter-clockwise with the trocar resulting in an oscillating and disorienting viewing image on the video monitor. The laparoscope lock 40 of the present invention improves visualization and  
10 enables a more precise placement of the trocar within the body tissue and across the body wall as compared to obturators of the prior art while preventing inadvertent axial movement of the laparoscope during handling and use.

In another aspect of the invention as illustrated in FIGS. 20 and 21, the bladeless obturator 18 further comprises a cap 42 that can be snap-fitted onto  
15 the proximal end of the obturator shaft 21, after which the laparoscope lock 40 can be snap-fitted onto the end of the cap 42. Both the cap 42 and the lock 40 can be formed of a plastic material such as polycarbonate. The obturator cap 42 can be provided with and without a pistol-grip handle. The handled version of the bladeless obturator provides a pistol-grip to ease insertion of the trocar system  
20 as illustrated in FIGS. 22 and 23. The pistol-grip handle is designed to nest into the handle on the trocar seal to prevent excessive flexure of the handle during insertion of the trocar as illustrated in FIG. 23. More particularly, the handled bladeless obturator includes three components comprising of an obturator shaft



21b, an obturator cap 42b having a pistol-grip handle 26b, and a laparoscope lock 40b, all of which can be injection molded out of polycarbonate. The pistol-grip handle 26b can be formed with two components frictionally fitted together with, for example, interference pins. The interference pins can be fitted into  
5 holes in the handle 26b to affect a frictional lock between the two components.

Referring to FIG. 24, the bladeless obturator 18 is designed to releasably attach to a trocar seal 17 via two cantilever snap-fits 70a, 70b. As the obturator 18 is inserted into the trocar seal 17 and cannula 12, the snap-fits 70a, 70b passively engage the trocar seal 17 and serve to axially lock the obturator 18 to  
10 the trocar seal 17 and cannula 12 (FIGS. 24 and 25). To release the obturator 18 from the trocar seal 17 and cannula 12, outboard tabs 72a, 72b on the obturator cap 42 are depressed inwardly and the obturator 18 is then free to be slidably removed as illustrated in FIGS. 26 and 27. Referring back to FIGS. 20 and 21, the bladeless obturator 18 includes axial key members 74 at its proximal  
15 end which are designed to mate with axial keyways on the trocar seal 17. As the bladeless obturator 18 is inserted into the trocar seal 17 and cannula 12, the obturator 18 is rotated slightly to align the axial key members 74 with the axial keyways and then advanced until the snap-fits 70a, 70b engage the trocar seal 17. The axial key members 74 serve to rotationally lock the obturator 18 to the  
20 trocar seal 17.

Referring to FIG. 28, there is shown another embodiment of the laparoscope lock 40c comprising a multiple-finger collet 80c comprising a plurality of fingers 82c. The multiple-finger collet 80c has an inner diameter that

is smaller than the outer diameter of the laparoscope. The fingers 82c of the collet 80c spread open during insertion of the laparoscope providing frictional engagement with the outer diameter of the laparoscope. The laparoscope lock 40c is free to rotate on an obturator cap 42c, and allows the laparoscope to freely rotate relative to the shaft of the bladeless obturator.

Referring back to FIGS. 20 and 21, the obturator shaft 21 of the bladeless obturator 18 can be configured with a barb 76 at its proximal end. The barb 76 is vertically slotted to enable the shaft 21 to flex during assembly. The obturator shaft 21 may also include a plurality of keys (not shown) near its proximal end.

10 The obturator cap 42 is configured to axially slide over the barb 76 on the obturator shaft 21 to affect a one-way snap-fit lock between the two components. This snap-fit prevents the removal of the obturator cap 42 from the obturator shaft 21. The obturator cap 42 may further include keyways (not shown) that engage the keys on the obturator shaft 21 to rotationally index the components

15 together. The obturator cap 42 may further include a second barb (not shown) at its proximal end. The laparoscope lock 40 may include a plurality of tabs (not shown) that are designed to spread and axially slide over the second barb on the obturator cap 42 to affect a one-way snap-fit lock between the obturator cap 42 and the laparoscope lock 40. This snap-fit prevents the axial removal of the

20 laparoscope lock 40 from the obturator cap 42. The laparoscope lock 40 is free to rotate relative to the obturator cap 42.

Referring to FIG. 29, there is shown another aspect of the invention of a laparoscope 30a having a tip 33a configured similar to that of the tip 27 of the

bladeless obturator 18 described above, the tip 33a being adapted to snap-fit or frictionally engage the end of the laparoscope 30a. With this configuration, the combination of the tip 33a and the laparoscope 30a serve to form an optical obturator having a blunt tip. Once the trocar is inserted and the laparoscope removed from the trocar seal and cannula, the bladeless tip 33a can then be removed from the laparoscope 30a. The bladeless tip 33a can be formed from either a disposable or reusable transparent material. The bladeless tip 33a can be temporarily or permanently affixed to the scope 30a by any of the known methods of attaching the two components together as explained above.

10 Referring to FIGS. 30 and 31, there is shown a laparoscope lock 40d in accordance with another embodiment of the invention including an active lock comprising a camming member 43d. With this type of lock, the laparoscope would first be inserted into the shaft of the obturator and then the lock 40d would be activated to lock the laparoscope in an axial position relative to the shaft. The lock 40d can either rotate freely to enable the laparoscope to rotate freely relative to the shaft or the lock 40d can be rotationally fixed to prevent the laparoscope from rotating relative to the shaft. In another aspect as illustrated in FIGS. 32 and 33, a lock 40e can include an active lock comprising a clamping member 45e. With this type of lock, the laparoscope would first be inserted into the shaft of the obturator and then the lock would be activated to lock the laparoscope in an axial position relative to the shaft. The lock 40e can either rotate freely to enable the laparoscope to rotate freely relative to the shaft or the lock 40e can be rotationally fixed to prevent the laparoscope from rotating relative to the shaft.

Referring to FIGS. 34 and 35, there is shown a lock 40f in accordance with another embodiment of the invention including an active lock comprising a locking collar 46 positioned eccentrically with respect to the axis of the obturator so that as the locking collar 46 is turned, a frictional engagement with the laparoscope is affected. The laparoscope would first be inserted into the locking collar 46 and the shaft of the obturator, the locking collar 46 can then be turned to frictionally engage the laparoscope. The laparoscope lock 40f can either rotate freely to enable the laparoscope to rotate freely relative to the shaft or the laparoscope lock 40f can be rotationally fixed to prevent the laparoscope from rotating relative to the shaft.

In another aspect of the invention as illustrated in FIGS. 36 and 37, there is shown a laparoscope lock 40g including an active lock comprising of a locking nut 48 and a thread. The threaded portion of the lock 40g has flexible elements similar to those on a collet. The laparoscope would first be inserted into the threaded portion of the lock 40g and the nut then rotated clockwise to collapse the flexible elements to frictionally engage the laparoscope. To release the laparoscope, the nut is rotated counter-clockwise.

In another aspect, the laparoscope lock can include a lock that includes an elastomeric element. The addition of the elastomeric element can enhance the frictional engagement with the laparoscope. An example of such an elastomeric element is a silicone O-ring sized with an inside diameter smaller than the outside diameter of the laparoscope. The laparoscope lock can either rotate freely to enable the laparoscope to rotate freely relative to the shaft or the

laparoscope lock can be rotationally fixed to prevent the laparoscope from rotating relative to the shaft.

In yet another aspect, the obturator 18 can also be used as an insufflation needle having a passageway and valve to administer carbon dioxide or other  
5 insufflation gas to the peritoneal cavity. The obturator 18 can also be used with an insufflation needle cannula in which case removal of the obturator 18 upon entry would allow for rapid insufflation of the peritoneal cavity.

In another aspect of the invention, the bladeless obturator can be formed with a 2-3 mm outer diameter and with a small thru-hole at its distal end. The  
10 bladeless obturator can be used in conjunction with a miniaturized laparoscope to provide initial access into a hollow body cavity. Once access is obtained, the laparoscope can be removed from the bladeless obturator and an insufflation gas such as carbon dioxide can be dispensed through the obturator into the hollow body cavity. The bladeless obturator can also include holes in the tip portion to  
15 enhance the flow of insufflation gases through the obturator. More particularly, the bladeless obturator can be formed with a 2-3 mm outer diameter and used in conjunction with a miniaturized laparoscope to provide initial access into a hollow body cavity. After access is obtained, the bladeless obturator can be removed from the trocar cannula and an insufflation gas such as carbon dioxide can be  
20 dispensed through the cannula and into the hollow body cavity.

It will be understood that many modifications can be made to the disclosed embodiments without departing from the spirit and scope of the invention. For example, various sizes of the surgical device are contemplated as well as various

types of constructions and materials. It will also be apparent that many modifications can be made to the configuration of parts as well as their interaction. For these reasons, the above description should not be construed as limiting the invention, but should be interpreted as merely exemplary of preferred  
5 embodiments.

CLAIMS

1. A surgical obturator adapted to separate body tissue, comprising:  
a shaft extending along an axis between a proximal end and a distal end;  
and  
a bladeless tip disposed at the distal end of the shaft and having a  
5 generally tapered configuration with an outer surface, said outer surface  
extending distally to a blunt point with a pair of side sections having a common  
shape and being separated by at least one intermediate section,  
wherein each of the side sections extends from the blunt point radially  
outwardly with progressive positions proximally along the axis, and  
10 wherein the shaft is sized and configured to receive an optical instrument  
having a distal end to receive an image of the body tissue.
2. The surgical obturator of Claim 1, wherein the tapered configuration  
facilitates separation of different layers of the body tissue and provides proper  
alignment of the tip between the layers.
3. The surgical obturator of Claim 1, wherein:  
the side sections include a distal portion and a proximal portion; and  
the distal portion of the side sections being twisted radially with respect to  
the proximal portion of the side sections.
4. The surgical obturator of Claim 1, wherein:

the intermediate section includes a distal portion and a proximal portion;  
the distal portion of the intermediate section being twisted in a first radial  
direction; and

5 the proximal portion of the intermediate section being twisted in a second  
radial direction opposite the first radial direction.

5. The surgical obturator of Claim 4, wherein the distal portion of the  
intermediate section has a width which increases proximally.

6. The surgical obturator of Claim 1, wherein the outer surface in  
radial cross-section has a general configuration of a geometric shape.

7. The surgical obturator of Claim 6, wherein the geometric shape is a  
rectangle with at least one pair of opposing arcuate sides.

8. The surgical obturator of Claim 1, wherein the shaft is hollow.

9. The surgical obturator of Claim 1, wherein the tip is transparent or  
translucent.

10. The surgical obturator of Claim 1, wherein the tip is formed from a  
plastic material or a glass material.



11. The surgical obturator of Claim 1, wherein at least at least one of the shaft and the tip is constructed from a reusable material.
12. The surgical obturator of Claim 1, wherein at least at least one of the shaft and the tip is constructed from a disposable material.
13. The surgical obturator of Claim 11, wherein the reusable material is a metallic material or an autoclavable polymer.
14. The surgical obturator of Claim 10, wherein the plastic material is at least one of polycarbonate, polyphenylsulfone, polyetherimide, acrylic, and polyvinyl chloride.
15. The surgical obturator of Claim 1, wherein the tip is generally hollow to receive the distal end of the optical instrument.
16. The surgical obturator of Claim 1, wherein the tip is substantially solid to receive the distal end of the optical instrument.
17. The surgical obturator of Claim 1, wherein the tip further comprises at least one portion that is marked differently from the rest of the tip to serve as a marker as the tip is being inserted into the body tissue.

18. The surgical obturator of Claim 17, wherein the at least one portion is marked with a different color from the rest of the tip.

19. The surgical obturator of Claim 1, wherein the tip is shaped and configured to receive the distal end of the optical instrument having a non-angled lens.

20. The surgical obturator of Claim 1, wherein the tip is shaped and configured to receive the distal end of the optical instrument having an angled lens.

21. The surgical obturator of Claim 1, wherein the tip further comprises a ledge to provide proper positioning of the distal end of the optical instrument having a non-angled lens or the optical instrument having an angled lens.

22. The surgical obturator of Claim 20, wherein the tip further comprises a bulbous section to accommodate the distal end of the angled lens optical instrument.

23. The surgical obturator of Claim 1, wherein the tip is coated or constructed from a soft elastomeric material.

24. The surgical obturator of Claim 1, wherein the tip is constructed from a solid elastomer or a composite elastomer/polymer.

25. The surgical obturator of Claim 1, wherein the shaft and the tip are connected together by adhesive bonding, ultrasonic welding, snap-fitting, shrink tubing, or by overmolding the tip over the shaft.

26. The surgical obturator of Claim 1, wherein the tip further comprises a cutout section to provide the distal end of the optical instrument with direct vision of the body tissue.

27. The surgical obturator of Claim 1, further comprising a lock disposed at the proximal end of the shaft to frictionally lock the optical instrument in an axial position in the shaft.

28. The surgical obturator of Claim 27, wherein the lock prevents the optical instrument from moving axially relative to the shaft.

29. The surgical obturator of Claim 27, wherein the lock allows the optical instrument to rotate freely about the shaft.

30. The surgical obturator of Claim 27, wherein the lock is constructed from a plastic material including polycarbonate.

31. The surgical obturator of Claim 27, wherein the lock is a multi-finger collet having an inner diameter smaller than an outer diameter of the optical instrument.

32. The surgical obturator of Claim 31, wherein the fingers of the collet spread open during insertion of the optical instrument providing frictional engagement with the outer diameter of the optical instrument.

33. The surgical obturator of Claim 27, wherein the lock further comprises a means for frictionally engaging the optical instrument in the axial position relative to the shaft.

34. The surgical obturator of Claim 33, wherein the frictionally engaging means includes a camming member.

35. The surgical obturator of Claim 33, wherein the frictionally engaging means includes a locking collar.

36. The surgical obturator of Claim 33, wherein the frictionally engaging means includes a locking nut and thread.

37. The surgical obturator of Claim 33, wherein the frictionally engaging means includes an elastomeric element.

38. The surgical obturator of Claim 37, wherein the elastomeric element is an O-ring.

39. The surgical obturator of Claim 1, further comprising a cap disposed at the proximal end of the shaft.

40. The surgical obturator of Claim 39, wherein the cap further comprises a handle.

41. A surgical obturator adapted to separate body tissue, comprising:  
a shaft extending along an axis between a proximal end and a distal end;  
and

a bladeless tip disposed at the distal end of the shaft having a tapered  
5 surface forming proximally into an outer surface, said outer surface including a  
pair of generally opposed sections,

wherein the outer surface has a generally geometric shape in progressive  
radial cross-sections from a distal cross-section to a proximal cross-section,

wherein the pair of generally opposed sections of the outer surface  
10 appears as a pair of lines in each of the progressive radial cross-sections,

wherein at least one of the pair of lines becomes more arcuate in the  
progressive radial cross-sections, and

wherein the shaft is sized and configured to receive an optical instrument  
having a distal end to receive an image of the body tissue.

42. The surgical obturator of Claim 41, wherein the area of the  
geometric shape increases along the progressive radial cross-sections.

43. The surgical obturator of Claim 42, wherein the at least one of the pair of lines rotates in a first direction around the axis in the progressive radial cross-sections.

44. The surgical obturator of Claim 43, wherein the at least one of the pair of lines rotates around the axis in a second direction opposite to the first direction in the progressive radial cross-sections.

45. The surgical obturator of Claim 41, wherein the shaft is hollow.

46. A surgical obturator, comprising:

a shaft extending along an axis between a proximal end and a distal end;

and

a bladeless tip disposed at the distal end of the shaft having a tapered

5 surface forming proximally into an outer surface, said outer surface extending distally to a blunt point,

wherein the shaft is sized and configured to receive an optical instrument having a distal end to receive an image of the body tissue.

47. The surgical obturator of Claim 46, wherein said outer surface includes a pair of side sections extending from the blunt point radially outwardly with progressive positions proximally along the axis.

48. The surgical obturator of Claim 46, wherein the shaft is hollow.

49. The surgical obturator of Claim 46, wherein the shaft is constructed of an autoclavable material.

50. The surgical obturator of Claim 49, wherein the autoclavable material is stainless steel.

51. The surgical obturator of Claim 49, wherein the autoclavable material is a polymer.

52. The surgical obturator of Claim 46, wherein the tip further comprises a cutout section to provide the distal end of the optical instrument with direct vision of the body tissue.

53. The surgical obturator of Claim 46, further comprising a lock disposed at the proximal end of the shaft to frictionally lock the optical instrument in an axial position in the shaft.

54. The surgical obturator of Claim 53, wherein the lock prevents the optical instrument from moving axially relative to the shaft.

55. The surgical obturator of Claim 53, wherein the lock allows the optical instrument to rotate freely about the shaft.

56. The surgical obturator of Claim 53, wherein the lock is constructed from a plastic material including polycarbonate.

57. The surgical obturator of Claim 53, wherein the lock is a multi-finger collet having an inner diameter smaller than an outer diameter of the optical instrument.

58. The surgical obturator of Claim 57, wherein the fingers of the collet spread open during insertion of the optical instrument providing frictional engagement with the outer diameter of the optical instrument.

59. The surgical obturator of Claim 53, wherein the lock further comprises a means for frictionally engaging the optical instrument in the axial position relative to the shaft.

60. The surgical obturator of Claim 59, wherein the frictionally engaging means includes a camming member.

61. The surgical obturator of Claim 59, wherein the frictionally engaging means includes a locking collar.

62. The surgical obturator of Claim 59, wherein the frictionally engaging means includes a locking nut and thread.

63. The surgical obturator of Claim 59, wherein the frictionally engaging means includes an elastomeric element.



64. The surgical obturator of Claim 63, wherein the elastomeric element is an O-ring.

65. An optical separator adapted to receive an image of a body tissue and to separate the body tissue, comprising:

an optical instrument having a proximal end and a distal end; and

a bladeless tip removably attached at the distal end of the optical

5 instrument and having a generally tapered configuration with an outer surface, said outer surface extending distally to a blunt point.

66. The optical separator of Claim 65, wherein the blunt point further comprises a pair of side sections having a common shape and being separated by at least one intermediate section, and

wherein each of the side sections extends from the blunt point radially

5 outwardly with progressive positions proximally along the axis.

67. The optical separator of Claim 65, wherein the tapered configuration facilitates separation of different layers of the body tissue and provides proper alignment of the tip between the layers.

68. The optical separator of Claim 66, wherein:

the side sections include a distal portion and a proximal portion; and

the distal portion of the side sections being twisted radially with respect to the proximal portion of the side sections.

69. The optical separator of Claim 66, wherein:  
the intermediate section includes a distal portion and a proximal portion;  
the distal portion of the intermediate section being twisted in a first radial  
direction; and

5 the proximal portion of the intermediate section being twisted in a second  
radial direction opposite the first radial direction.

70. The optical separator of Claim 69, wherein the distal portion of the  
intermediate section has a width which increases proximally.

71. The optical separator of Claim 65, wherein the outer surface in  
radial cross-section has a general configuration of a geometric shape.

72. The optical separator of Claim 71, wherein the geometric shape is a  
rectangle with at least one pair of opposing arcuate sides.

73. The optical separator of Claim 65, wherein the tip is transparent or  
translucent.

74. A bladeless tip adapted to be removably attached to a distal end of  
an optical instrument for receiving an image of a body tissue and to separate  
body tissue, said bladeless tip having a generally tapered configuration with an  
outer surface, said outer surface extending distally to a blunt point with a pair of  
5 side sections having a common shape and being separated by at least one

intermediate section, wherein each of the side sections extends from the blunt point radially outwardly with progressive positions proximally along the axis.

75. The bladeless tip of Claim 74, wherein the tapered configuration facilitates separation of different layers of the body tissue and provides proper alignment of the tip between the layers.

76. The bladeless tip of Claim 74, wherein:  
the side sections include a distal portion and a proximal portion; and  
the distal portion of the side sections being twisted radially with respect to the proximal portion of the side sections.

77. The bladeless tip of Claim 74, wherein:  
the intermediate section includes a distal portion and a proximal portion;  
the distal portion of the intermediate section being twisted in a first radial direction; and

5 the proximal portion of the intermediate section being twisted in a second radial direction opposite the first radial direction.

78. The bladeless tip of Claim 77, wherein the distal portion of the intermediate section has a width which increases proximally.

79. The bladeless tip of Claim 74, wherein the outer surface in radial cross-section has a general configuration of a geometric shape.

80. The bladeless tip of Claim 79, wherein the geometric shape is a rectangle with at least one pair of opposing arcuate sides.

81. The bladeless tip of Claim 74, wherein the tip is transparent or translucent.

82. The bladeless tip of Claim 74, wherein the tip is formed from a plastic material or a glass material.

83. The bladeless tip of Claim 74, wherein the tip is formed from a reusable or disposable material.

84. The bladeless tip of Claim 82, wherein the plastic material is at least one of polycarbonate, polyphenylsulfone, polyetherimide, acrylic, and polyvinyl chloride.

85. The blades tip of Claim 74, wherein the tip is generally hollow to receive the distal end of the optical instrument.

86. The bladeless tip of Claim 74, wherein the tip is substantially solid to receive the distal end of the optical instrument.

87. The bladeless tip of Claim 74, wherein the tip is shaped and configured to receive the distal end of the optical instrument having a non-angled lens.

88. The bladeless tip of Claim 74, wherein the tip is shaped and configured to receive the distal end of the optical instrument having an angled lens.

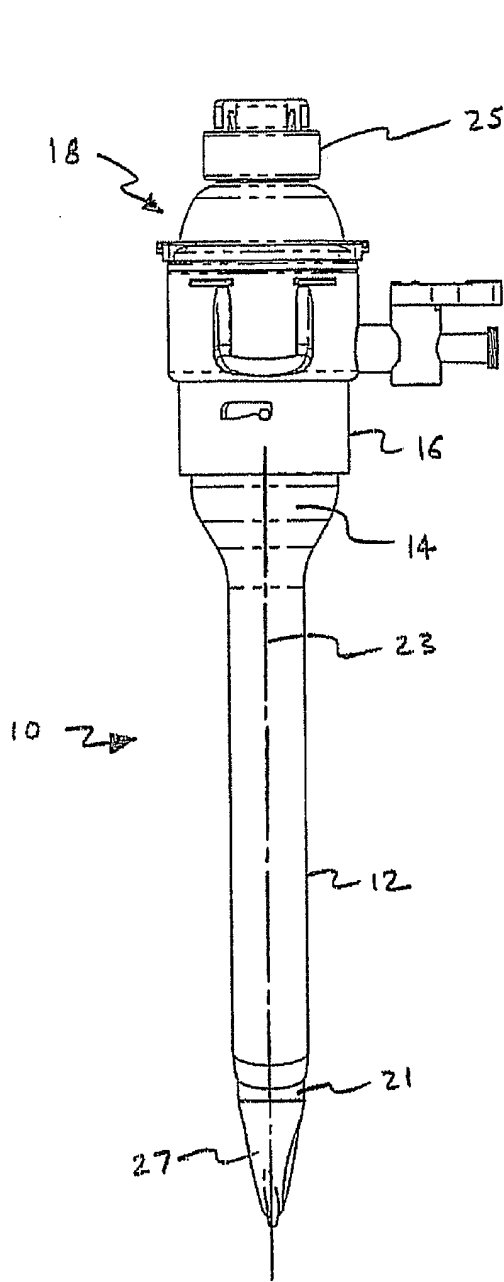

FIG. 1A

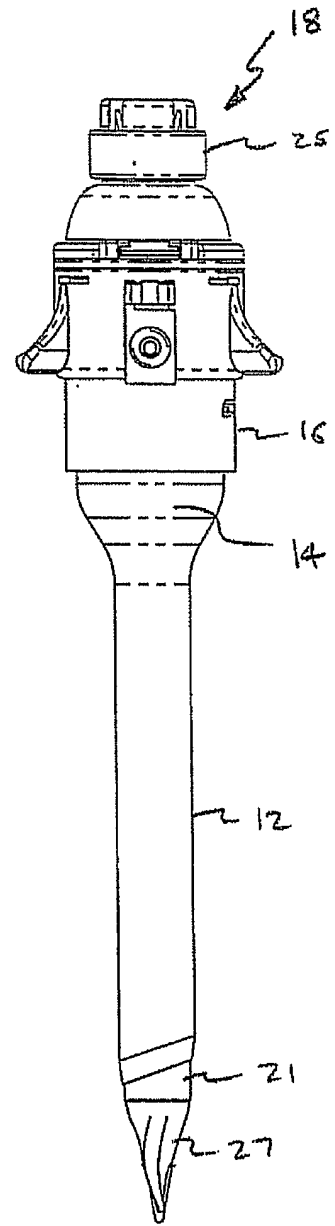

FIG. 1B

2 / 23

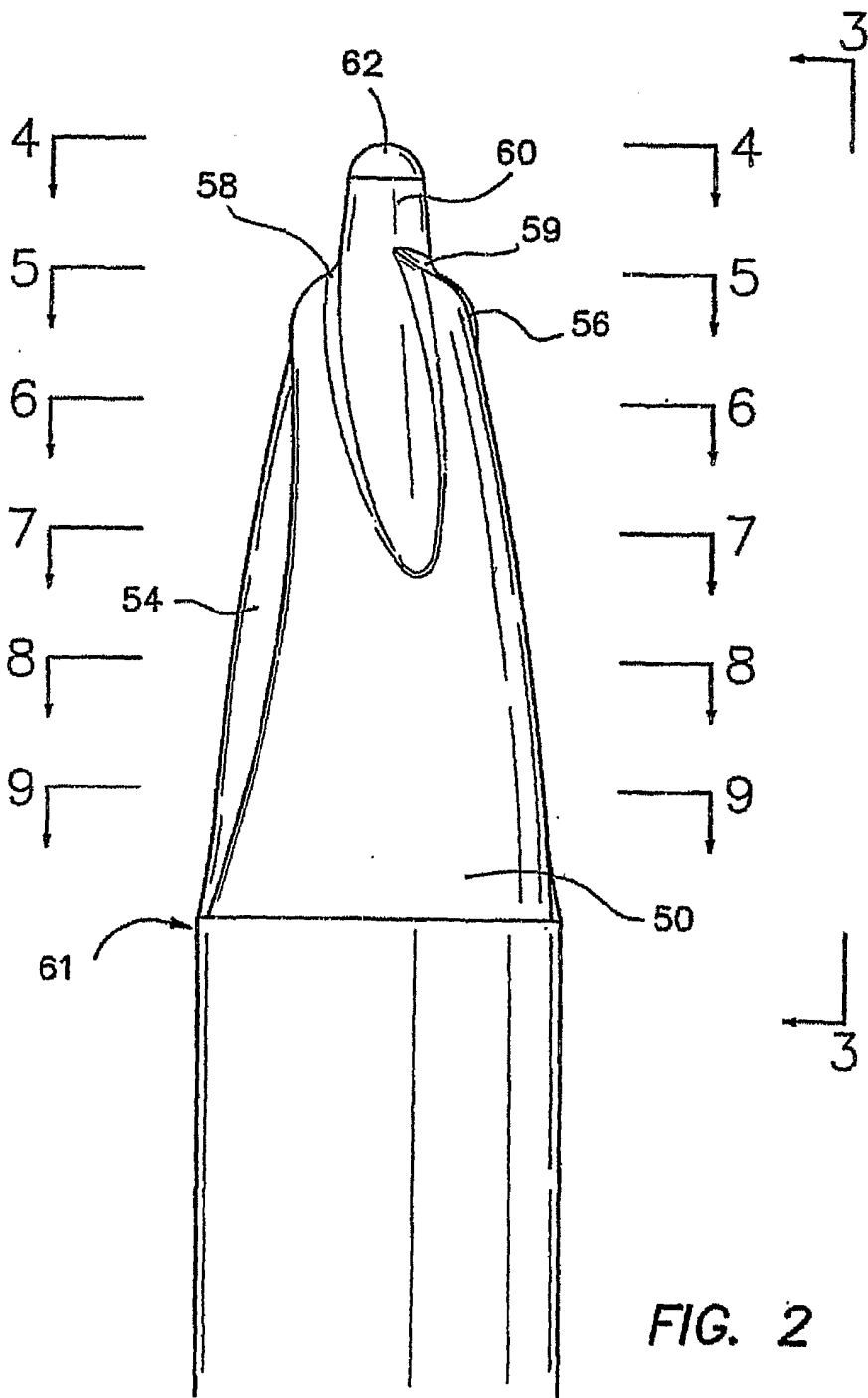

FIG. 2

3 / 23

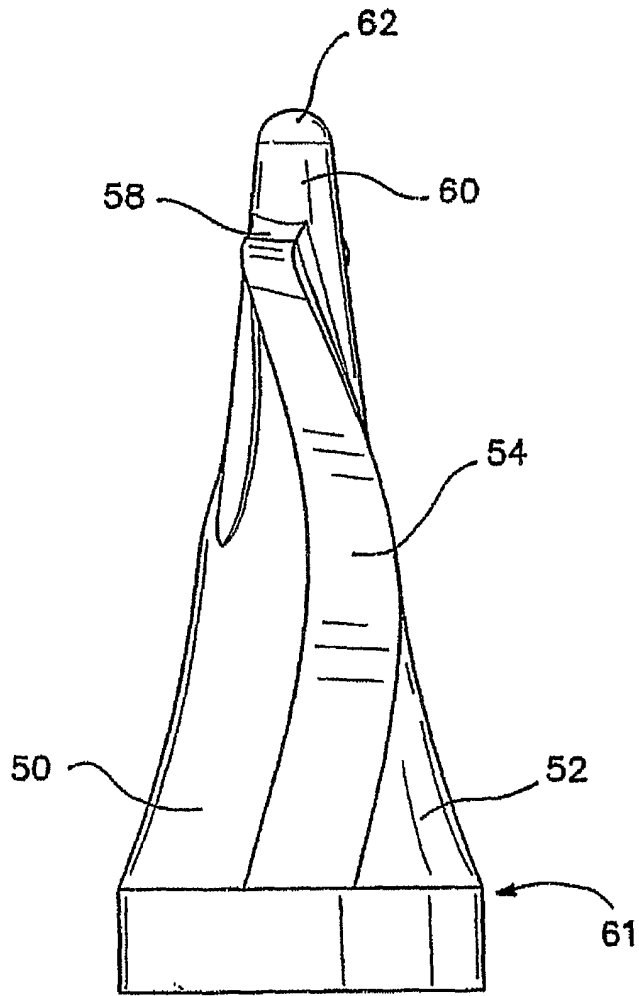

FIG. 3



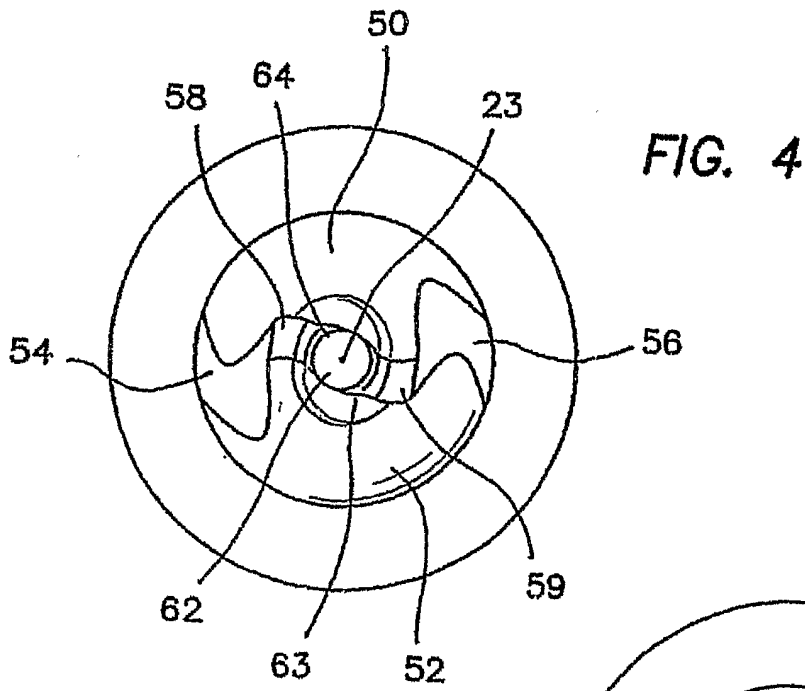

FIG. 4

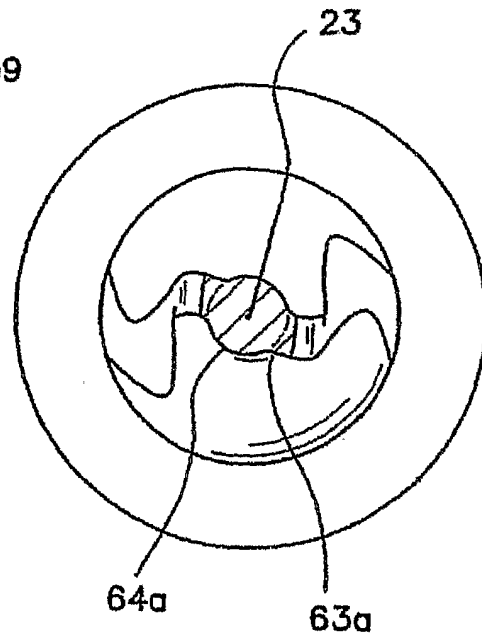

FIG. 5

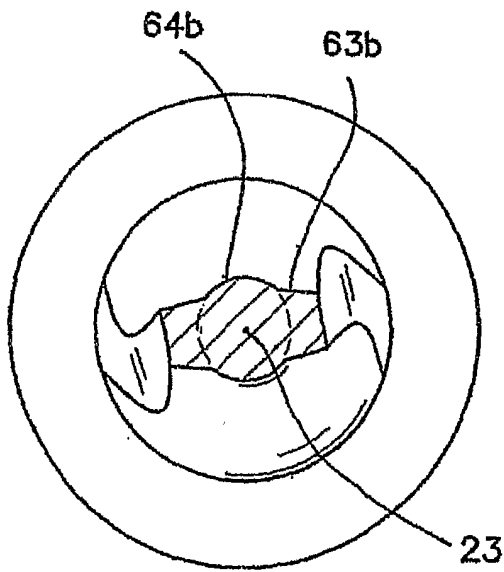

FIG. 6

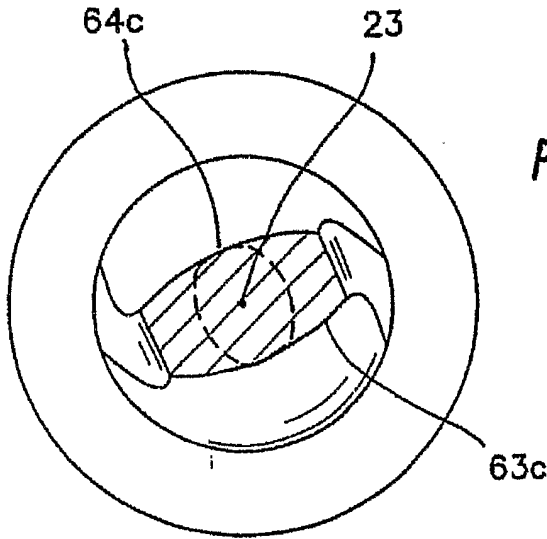

FIG. 7

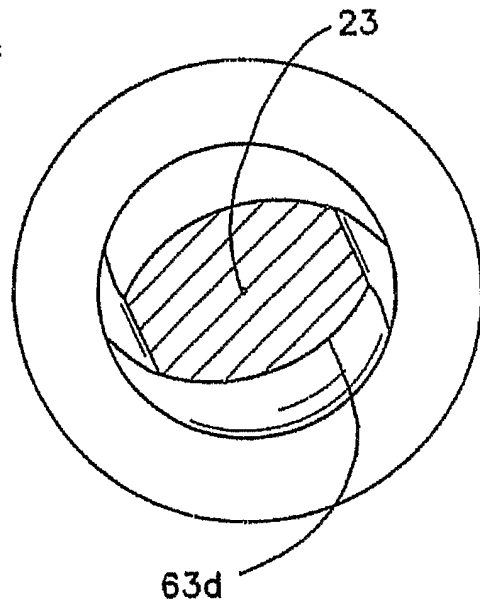

FIG. 8

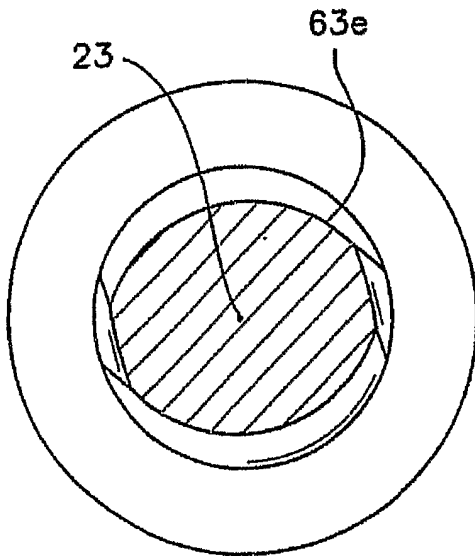

FIG. 9

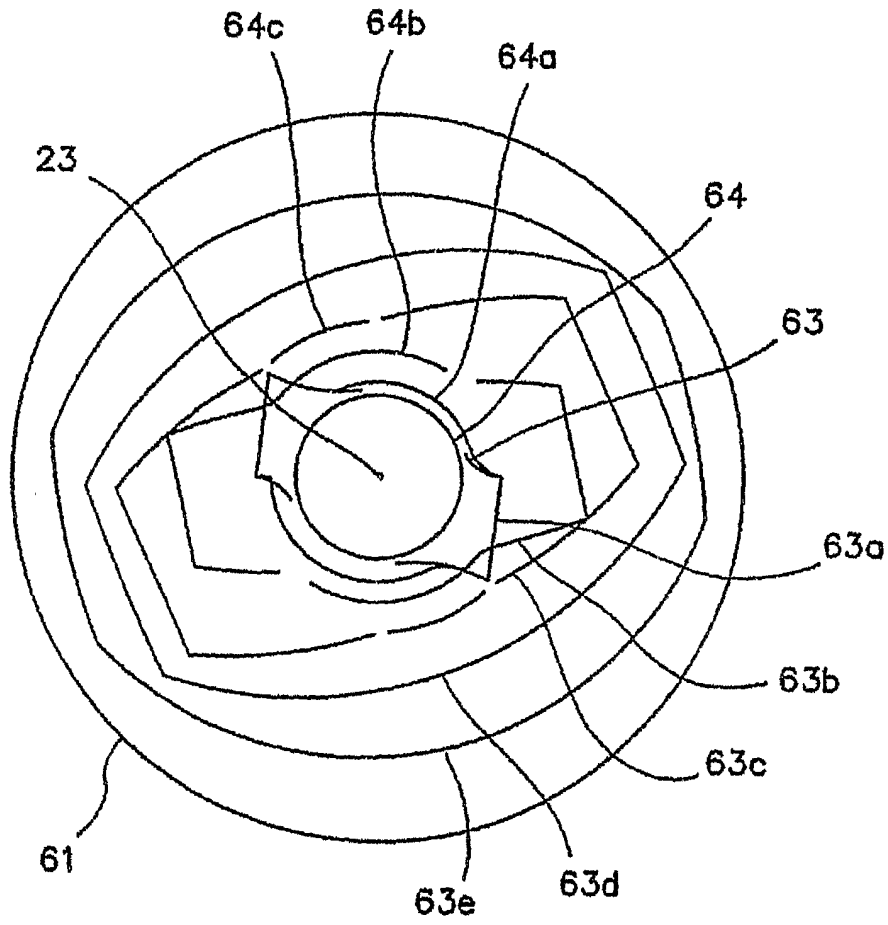

FIG. 10

7 / 23

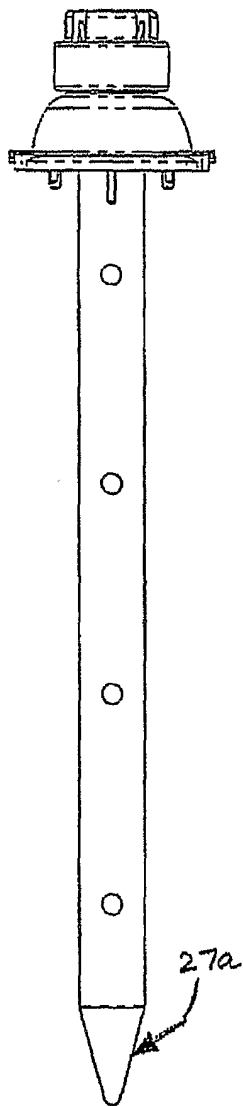

FIG. 11

8 / 23

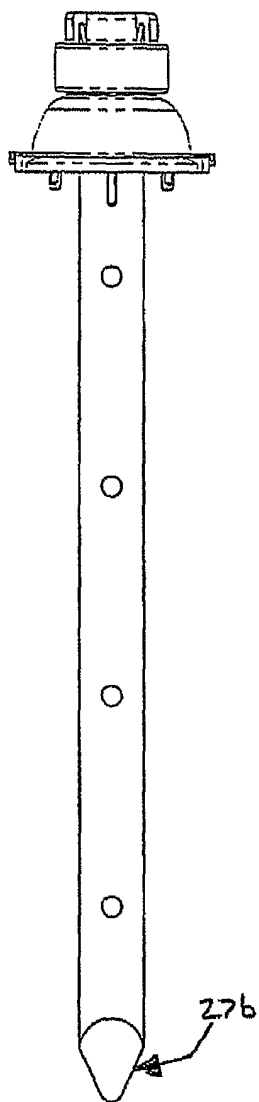

FIG. 12

9 / 23

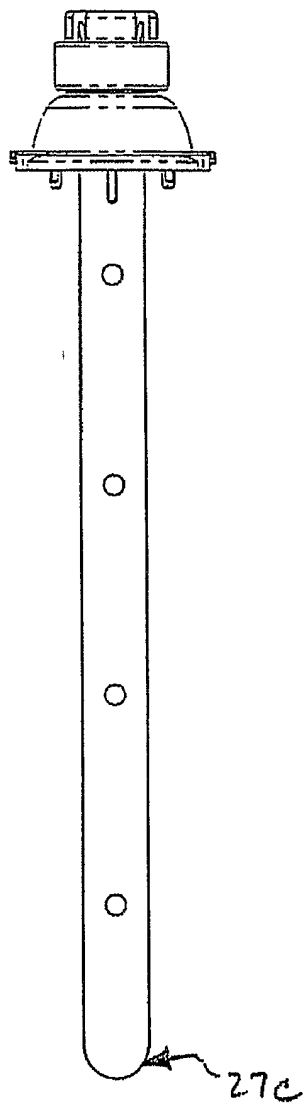

FIG. 13

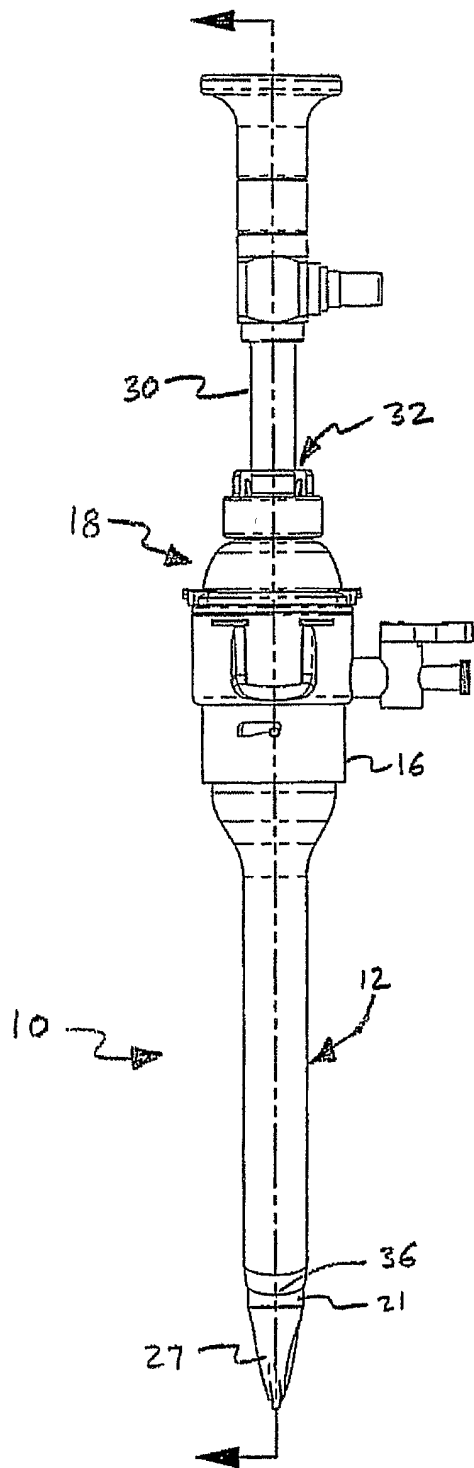

FIG. 14

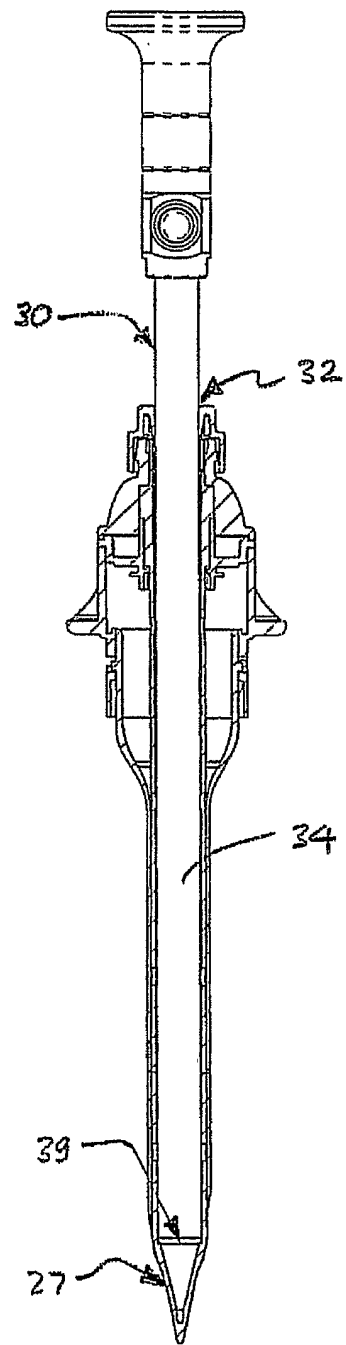

FIG. 15

11 / 23

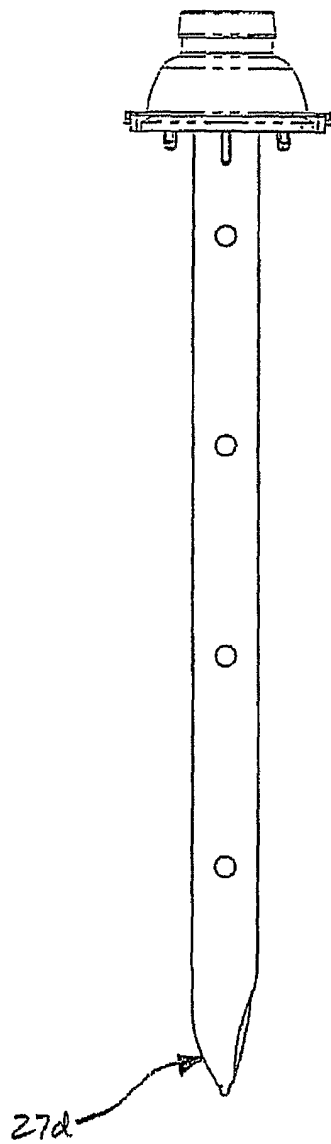

FIG. 16



12 / 12

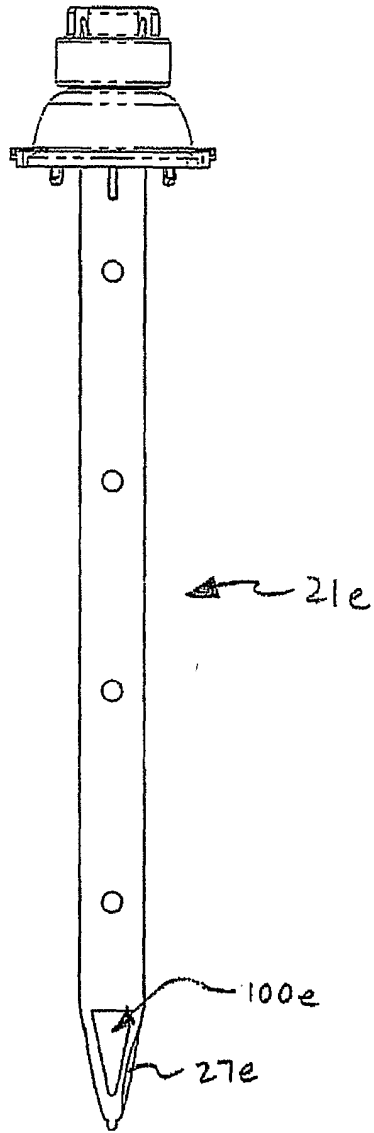

FIG. 17

13 / 23

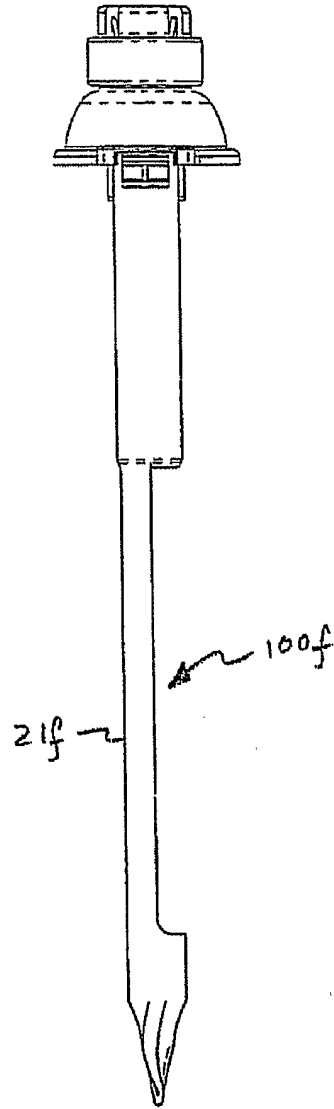

FIG. 18

14 / 23

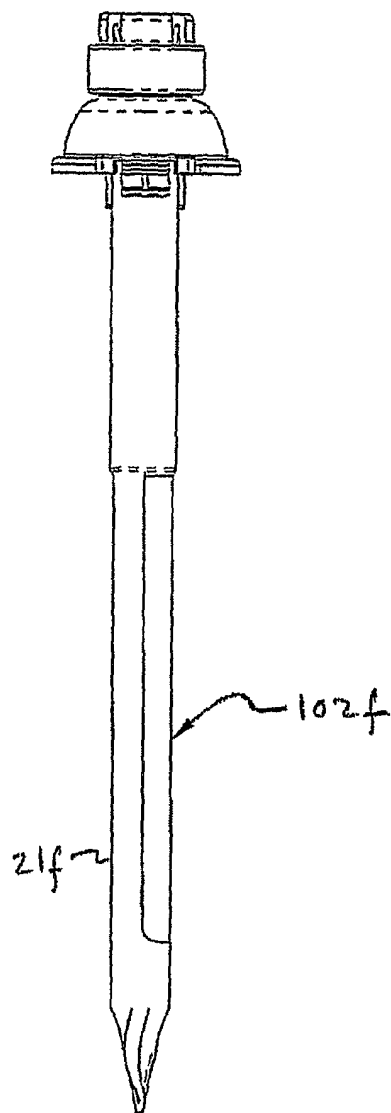

FIG. 19

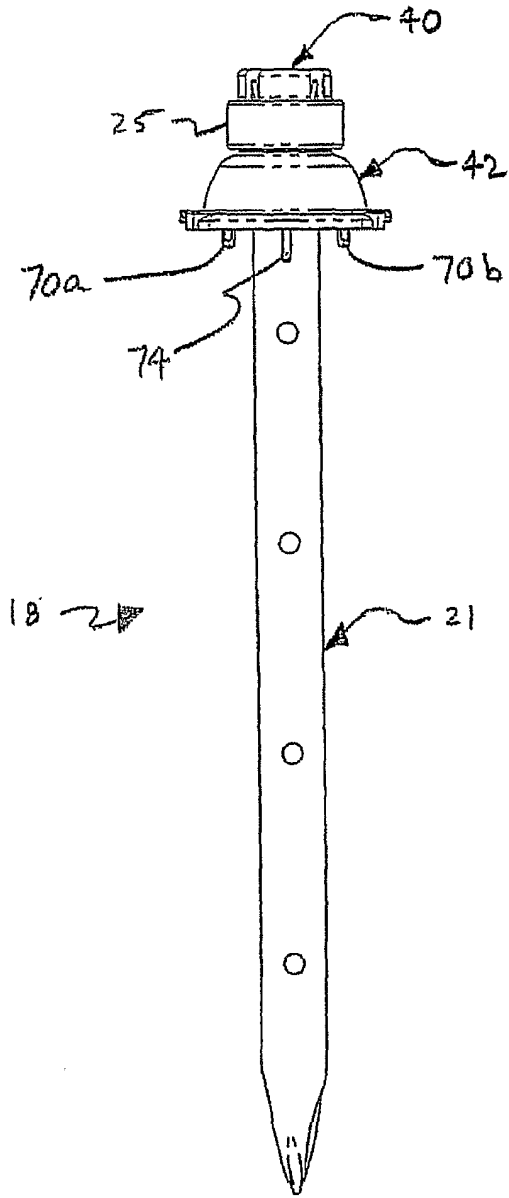

FIG. 20

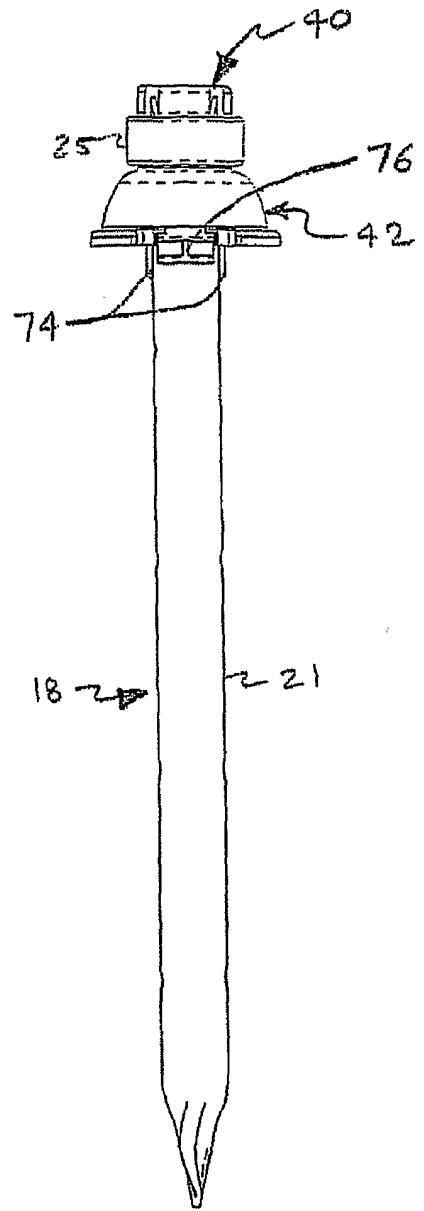

FIG. 21

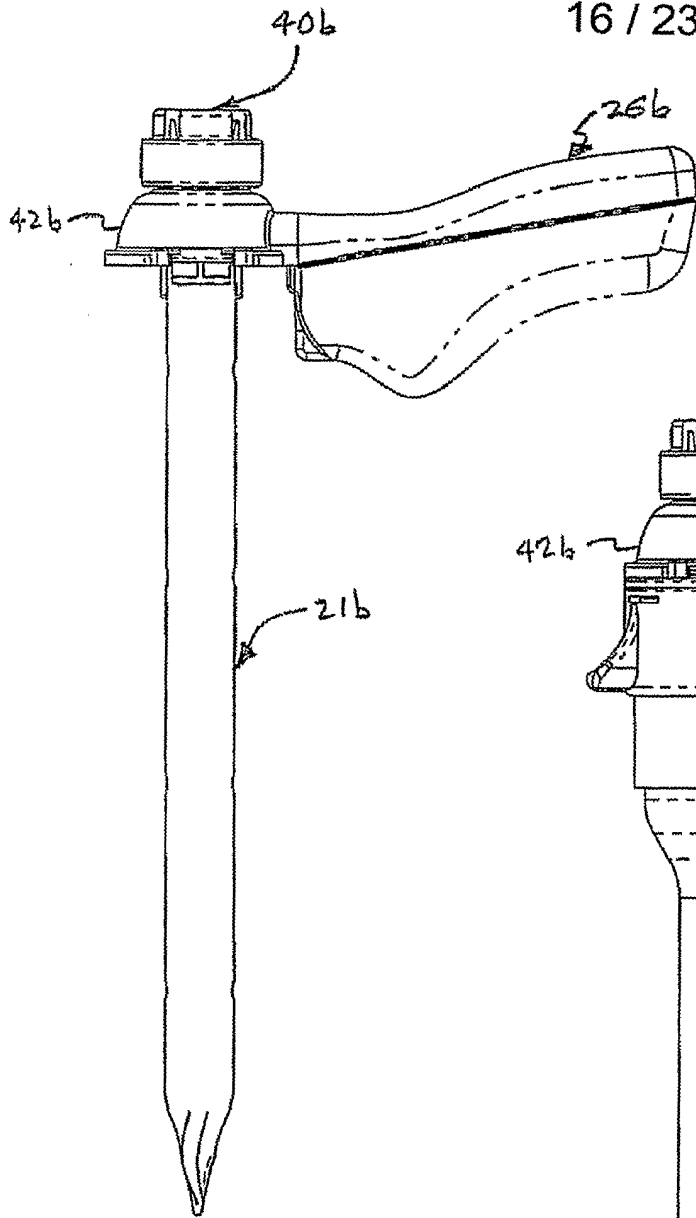

FIG. 22

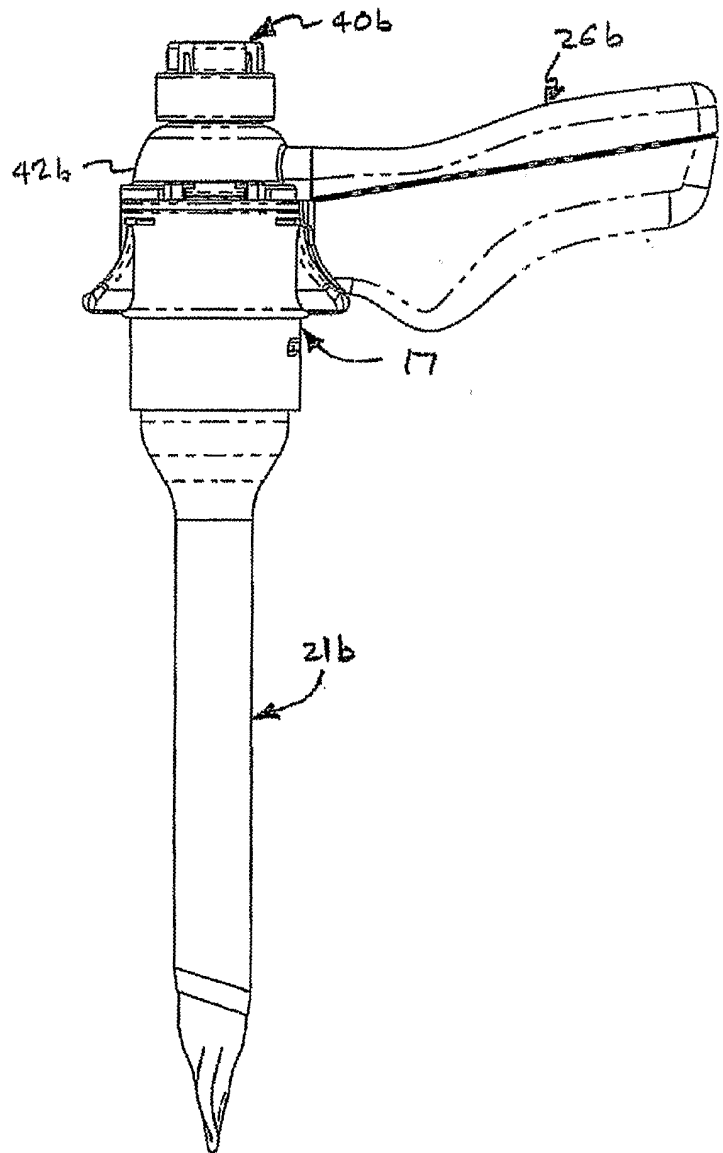

FIG. 23

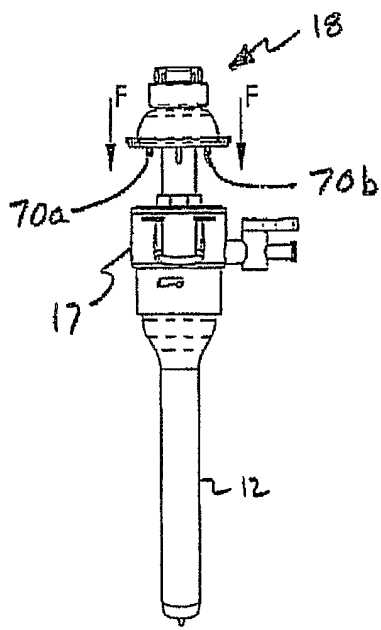

FIG. 24

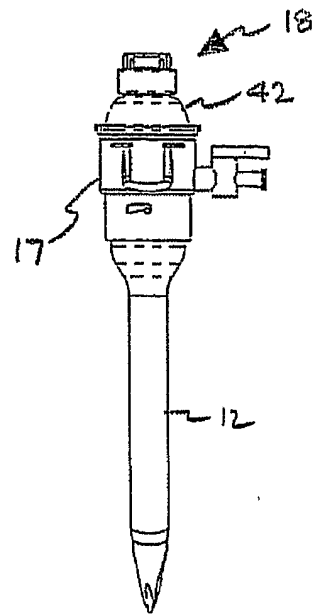

FIG. 25

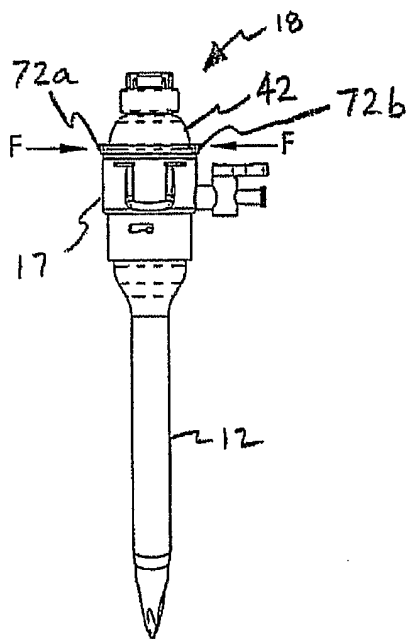

FIG. 26

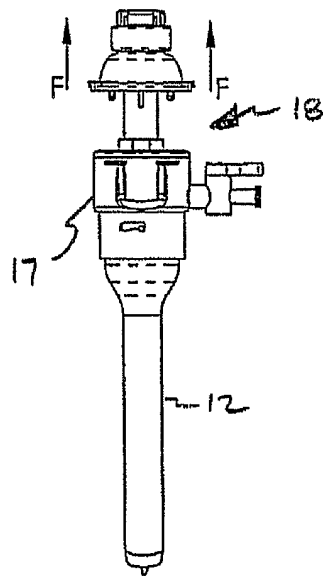

FIG. 27

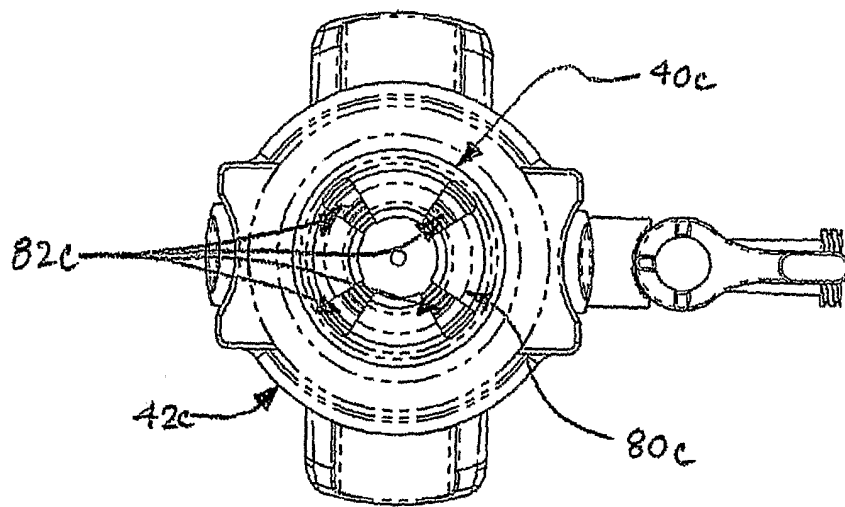

FIG. 28

19 / 23

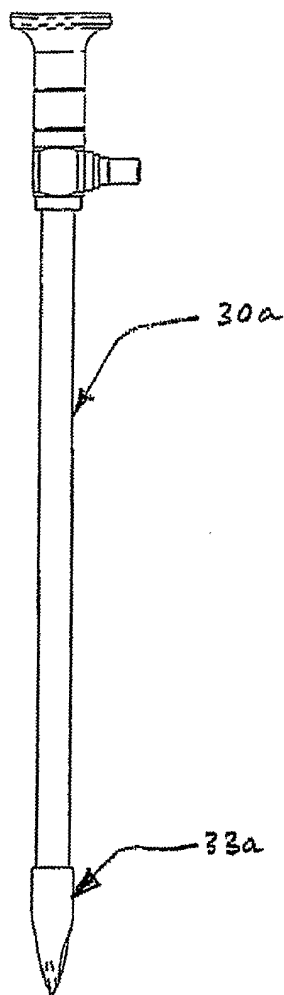

FIG. 29



20 / 23

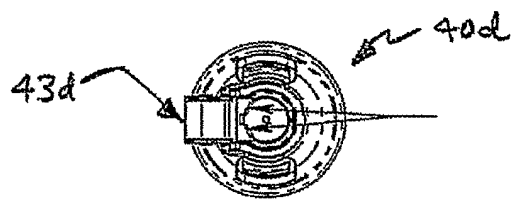

FIG. 30

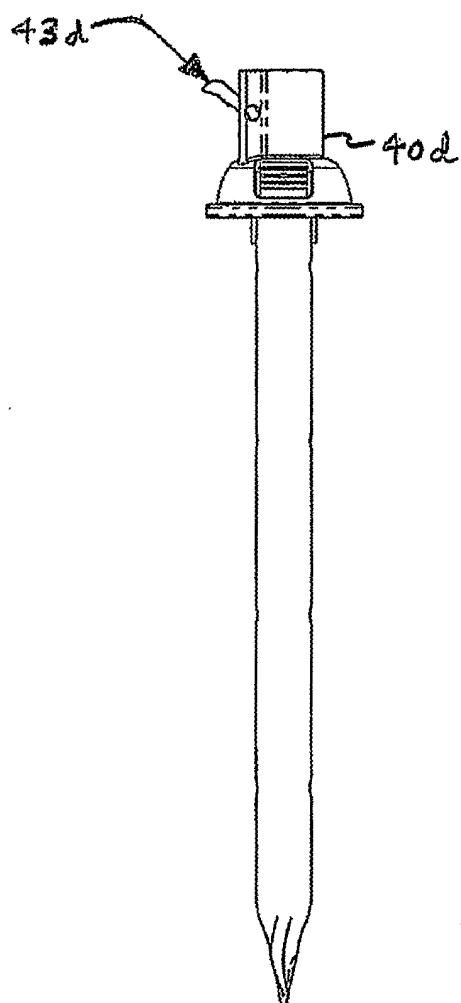

FIG. 31

21 / 23

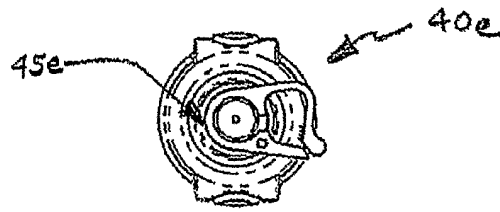

FIG. 32

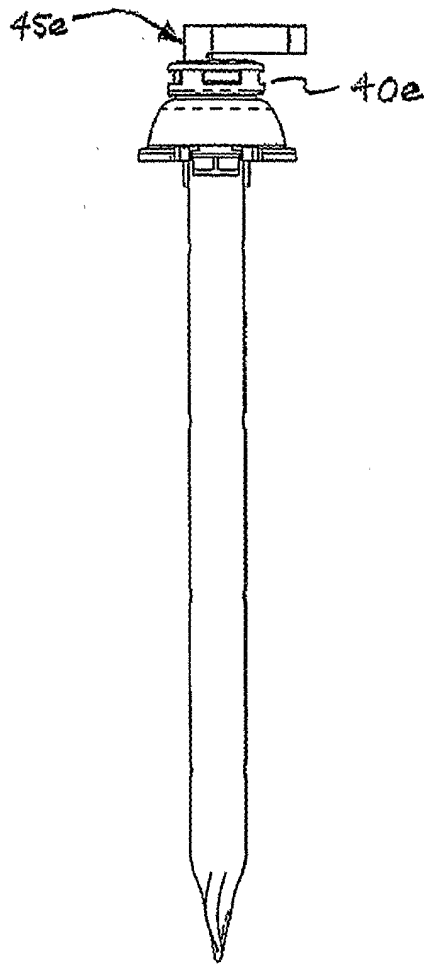

FIG. 33

22 / 23

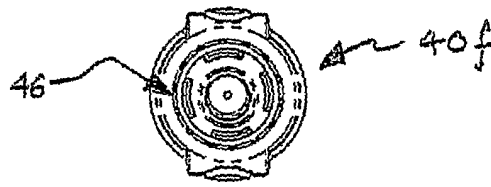

FIG. 34

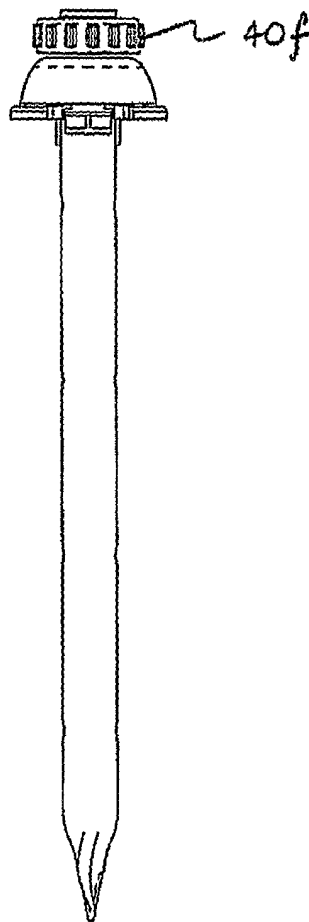

FIG. 35

23 / 23

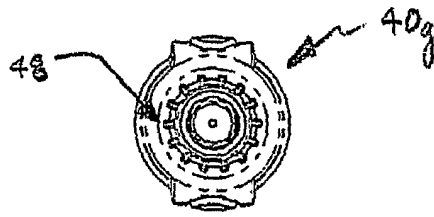

FIG. 36

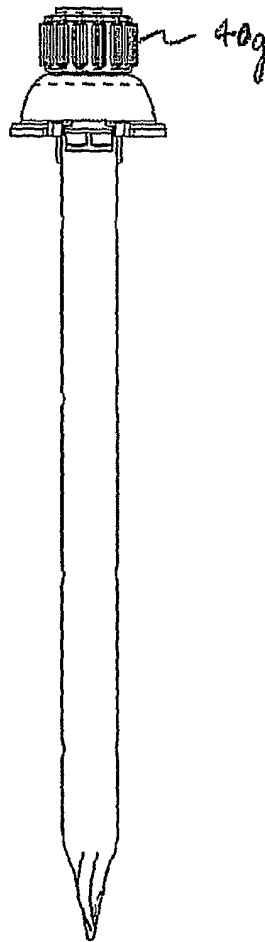

FIG. 37