

(19) World Intellectual Property Organization
International Bureau



(43) International Publication Date
7 September 2007 (07.09.2007)

PCT

(10) International Publication Number
WO 2007/101026 A2

- (51) International Patent Classification:
G01B 9/02 (2006.01) A61B 5/00 (2006.01)
G01N 21/47 (2006.01)
- (21) International Application Number:
PCT/US2007/062465
- (22) International Filing Date:
21 February 2007 (21.02.2007)
- (25) Filing Language: English
- (26) Publication Language: English
- (30) Priority Data:
60/776,544 24 February 2006 (24.02.2006) US
- (71) Applicant (for all designated States except US): **THE GENERAL HOSPITAL CORPORATION** [US/US]; 55 Fruit Street, Boston, MA 02114 (US).
- (72) Inventors; and
- (75) Inventors/Applicants (for US only): **DESJARDINS, Adrien, E.** [CA/US]; 17 Rear Endicott Avenue, Apt. 2, Somerville, MA 02144 (US). **VAKOC, Benjamin, J.** [US/US]; 3 Sargent Street, Cambridge, MA 02140 (US). **TEANEY, Guillermo, J.** [US/US]; 12 Fairmont Street, Cambridge, MA 02139 (US). **BOUMA, Brett, E.** [US/US]; 12 Monmouth Street, Quincy, MA 02171 (US).

- (74) Agents: **ABELEV, Gary** et al.; Dorsey & Whitney LLP, 250 Park Avenue, New York, NY 10177 (US).
- (81) Designated States (unless otherwise indicated, for every kind of national protection available): AE, AG, AL, AM, AT, AU, AZ, BA, BB, BG, BR, BW, BY, BZ, CA, CH, CN, CO, CR, CU, CZ, DE, DK, DM, DZ, EC, EE, EG, ES, FI, GB, GD, GE, GH, GM, GT, HN, HR, HU, ID, IL, IN, IS, JP, KE, KG, KM, KN, KP, KR, KZ, LA, LC, LK, LR, LS, LT, LU, LV, LY, MA, MD, MG, MK, MN, MW, MX, MY, MZ, NA, NG, NI, NO, NZ, OM, PG, PH, PL, PT, RO, RS, RU, SC, SD, SE, SG, SK, SL, SM, SV, SY, TJ, TM, TN, TR, TT, TZ, UA, UG, US, UZ, VC, VN, ZA, ZM, ZW.
- (84) Designated States (unless otherwise indicated, for every kind of regional protection available): ARIPO (BW, GH, GM, KE, LS, MW, MZ, NA, SD, SL, SZ, TZ, UG, ZM, ZW), Eurasian (AM, AZ, BY, KG, KZ, MD, RU, TJ, TM), European (AT, BE, BG, CH, CY, CZ, DE, DK, EE, ES, FI, FR, GB, GR, HU, IE, IS, IT, LT, LU, LV, MC, NL, PL, PT, RO, SE, SI, SK, TR), OAPI (BF, BJ, CF, CG, CI, CM, GA, GN, GQ, GW, ML, MR, NE, SN, TD, TG).

Published:
— without international search report and to be republished upon receipt of that report

For two-letter codes and other abbreviations, refer to the "Guidance Notes on Codes and Abbreviations" appearing at the beginning of each regular issue of the PCT Gazette.

(54) Title: METHODS AND SYSTEMS FOR PERFORMING ANGLE-RESOLVED FOURIER-DOMAIN OPTICAL COHERENCE TOMOGRAPHY

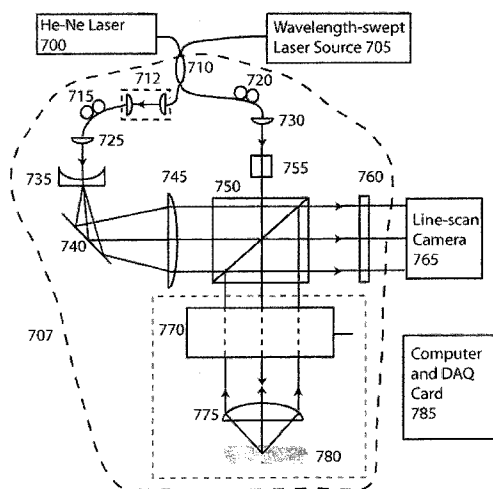

(57) Abstract: Arrangements, apparatus and methods are provided according to exemplary embodiments of the present invention. In particular, at least one first electro-magnetic radiation may be received and at least one second electro-magnetic radiation within a solid angle may be forwarded to a sample. The second electro-magnetic radiation may be associated with the first electro-magnetic radiation. A plurality of third electro-magnetic radiations can be received from the sample which is associated with the second electro-magnetic radiation, and at least one portion of the third electro-magnetic radiation is provided outside a periphery of the solid angle. Signals associated with each of the third electro-magnetic radiations can be simultaneously detected, with the signals being associated with information for the sample at a plurality of depths thereof. The depths can be determined using at least one of the third electro-magnetic radiations without a need to utilize another one of the third electro-magnetic radiations.

WO 2007/101026 A2

**METHODS AND SYSTEMS FOR PERFORMING ANGLE-RESOLVED
FOURIER-DOMAIN OPTICAL COHERENCE TOMOGRAPHY**

CROSS-REFERENCE TO RELATED APPLICATION(S)

This application is based upon and claims the benefit of priority from U.S.

- 5 Patent Application Serial No. 60/776,544, filed February 24, 2006, the entire disclosure of which is incorporated herein by reference.

STATEMENT REGARDING FEDERALLY SPONSORED RESEARCH

The invention was made with the U.S. Government support under Contract No. R01 CA103769 awarded by the National Institutes of Health. Thus, the U.S.

- 10 Government has certain rights in the invention.

FIELD OF THE INVENTION

- The present invention relates to methods and systems for performing angle-resolved Fourier-domain optical coherence tomography, and more particularly to measuring spatially-resolved angular backscattering distributions from transparent
15 and turbid samples using Fourier-domain optical coherence tomography techniques.

BACKGROUND OF THE INVENTION

- Optical coherence tomography ("OCT") enables cross-sectional images of biological samples to be obtained with resolution on a scale of several microns to tens of microns, thus allowing for detailed imaging of a tissue microstructure. It has been
20 demonstrated that Fourier-domain OCT ("FD-OCT") can provide a significantly improved sensitivity over the time-domain OCT, which enables high-speed imaging. For example, FD-OCT has been implemented in two configurations, e.g., spectral-domain OCT ("SD-OCT") and optical frequency domain imaging ("OFDI"), as

described in at least one of International Patent Application PCT/US2004/029148,
filed September 8, 2004, U.S. Patent Application No. 11/266,779, filed November 2,
2005, and U.S. Patent Application No. 10/501,276, filed July 9, 2004. FD-OCT has
been shown to have significant potential as a tool for identifying morphological
5 changes in many clinical contexts, including cardiovascular, gastrointestinal, and
retinal imaging.

One limitation of conventional OCT systems and methods is that the
backscattered light from only one angular range centered at 180 degrees is collected.
The same is the case for optical coherence microscopy (“OCM”) systems, in which
10 the array detection can be used to generate en-face two-dimensional images without
beam scanning. An example of one such OCM system is shown in Figure 1, as
described in E. Beaurepaire et al., “Full-field optical coherence microscopy,” *Optics
Letters* 23(4): 244-246, 1998. An acquisition of light backscattered from different
angles can be implemented using a technique of angular compounding, which may
15 reduce speckle. Speckle generally manifests itself as a checkered pattern within
scattering regions of the image, and makes it more difficult to discern subtle
reflectance differences in the tissue reflectance.

A method and system for acquiring backscattered light at different incident
angles in the context of OCT enabling angular compounding employs path length
20 encoding. The example of such system is shown in Figure 2, as described in N.
Iftimia et al., “Speckle reduction in optical coherence tomography by ‘path length
encoded’ angular compounding,” *Journal Of Biomedical Optics* 8(2): 260-263, 2003.
For example, an optical glass can be placed in the imaging beam path, splitting the
incident field into two or more beamlets. This optical glass causes a portion of the

incident beam (beamlet 2) to experience a greater path length delay than beamlet 1. In addition, beamlet 2 illuminates the sample at a different angle than beamlet 1. As a result, multiple OCT images of the sample (each acquired at a different angle) appear simultaneously on the OCT display. While being amenable to high-speed imaging, these method and system generally do not scale appropriately to a large number of angles, and can involve a tradeoff between the spatial resolution and the number of angles acquired thereby.

Another method and system translates a right angle prism, directing light from the sample arm to different positions on the focusing lens. An example of such system is shown in Figure 3, as described in M. Bashkansky et al., "Statistics and reduction of speckle in optical coherence tomography," *Optics Letters* 25(8): 545-547, 2000. In these method and system, a backscattered light at a narrow angular range centered at 180 degrees is generally collected, but the angle of incidence of the incident beam with respect to the sample normal varies with the position of the prism. Such method and system likely do not provide for (or even allow) a measurement of angular backscattering distributions. The speed at which the images can be acquired may be limited by the speed at which the prism can be translated in an oscillatory manner. In yet another method and system, detection of the OCT signals with four detectors can be performed simultaneously, which enables angular compounding for the speckle reduction. An example of such system is shown in Figure 4, as described in J.M. Schmitt, "Array detection for speckle reduction in optical coherence microscopy," *Physics In Medicine And Biology* 42(7): 1427-1439, 1997. In particular, the reference beam in this system is generally not larger than the incident beam. Thus, this system may not be conducive to measurements of the angular backscattering distributions. Furthermore, while each detector element receives the

light backscattered at a different angle, the solid angle subtended by the light collected for a given detector element is contained entirely within that subtended by the incident beam. The detection in this system is performed in the time domain.

In the field of light-scattering spectroscopy, it is known that the angular
5 distributions of backscattered light generally contain information regarding the size
distributions of the scattering particles within the tissue. Given the optical resolution
limitations of OCT, the ability to derive robust contrast between tissues with subtle
differences in reflectance properties may (in certain circumstances) utilize the
measurements of the angular distributions of the backscattered light. Depth-resolved
10 angular backscattering measurements using the low-coherence interferometry have
been designed for the light-scattering measurements with high angular resolution, as
shown in the arrangements of Figures 5(a) and 5(b), as described in A. Wax et al.,
“Measurement of angular distributions by use of low-coherence interferometry for
light-scattering spectroscopy,” *Optics Letters* 26(6): 322-324, 2001, and Figures 6(a)
15 and 6(b), as described in J.W. Pyhtila et al., “Determining nuclear morphology using
an improved angle-resolved low coherence interferometry system,” *Optics Express*
15(25): 3474-3484, 2003.

For example, light from a low-coherence source is divided into two arms of a
modified Michelson interferometer, one beam being incident on the sample (or a
20 sample arm) and another being incident on a mirror (or a reference arm). A lens
placed in the reference arm can be translated in a direction parallel to the mirror face
in order to provide the selectivity for different backscattering angles in the former
arm. Measurements of interfered light are generally made in either the time domain
(using the arrangement shown in Figures 5(a) and 5(b)) or the frequency domain

(using the arrangement shown in Figures 6(a) and 6(b)). These techniques generally do not permit simultaneous measurements of the angular backscattering distributions, and the measurement speed is likely limited by the speed at which the lens can be precisely translated. While optimized for angular, point-sampling, in-situ
5 measurements, angle-resolved LCI in its current implementations may likely be unsuitable for in-vivo clinical imaging.

Accordingly, there is a need to overcome the deficiencies described herein above. Indeed, simultaneously measuring the light that is backscattered from multiple angles in the imaging context of the optical coherence tomography may allow for high
10 levels of speckle reduction and additional forms of image contrast.

Accordingly, there is a need to overcome the deficiencies described herein above.

OBJECTS AND SUMMARY OF THE INVENTION

To address and/or overcome the above-described problems and/or
15 deficiencies, exemplary embodiments of systems, apparatus and methods according to the present invention are provided for measuring spatially-resolved angular backscattering distributions from transparent and turbid samples using Fourier-domain optical coherence tomography principles. In addition, according to further exemplary embodiments of the present invention, systems and methods for utilizing
20 the backscattering distributions are provided for performing speckle reduction and for generating image contrast.

Thus, in accordance with one exemplary embodiment of the present invention, apparatus and method are provided. In particular, at least one first electro-magnetic

radiation can be received and at least one second electro-magnetic radiation within a solid angle may be forwarded to a sample. The second electro-magnetic radiation may be associated with the first electro-magnetic radiation. A plurality of third electro-magnetic radiations can be received from the sample which is associated with
5 the second electro-magnetic radiation, and at least one portion of the third electro-magnetic radiation is provided outside a periphery of the solid angle. Signals associated with each of the third electro-magnetic radiations can be simultaneously detected, with the signals being associated with information for the sample at a plurality of depths thereof. The depths can be determined using at least one of the
10 third electro-magnetic radiations without a need to utilize another one of the third electro-magnetic radiations.

In addition, an interference can be detected between the two of the third radiations and at least one fourth radiation associated with the first radiation, and information associated with the sample can be obtained as a function of the depths
15 within the sample based on the interference. Data associated with at least one of birefringence properties, spectroscopic properties, motion, angular back-scattering properties or elastic properties of at least one portion of the sample can be provided as a function of the signals. At least one image of at least one portion of the sample can be generated as a function of the signals. The data associated with at least one of
20 birefringence properties, spectroscopic properties, motion, angular back-scattering properties or elastic properties of at least one portion of the sample can also be provided as a function of the signals. The data can be contrast data associated with the image. Data associated with scattering characteristics of at least one portion of the sample can also be provided as a function of a combination of the signals. Further,

the depths may be determined using a single one of the third electro-magnetic radiations.

According to another exemplary embodiment of the present invention, apparatus and method can provided which facilitate the production of data associated
5 with at least one sample. For example, first information associated with signals for a plurality of electro-magnetic radiations provided from the at least one sample can be received. At least first one of the electro-magnetic radiations may be provided along a first axis, and at least second one of the electro-magnetic radiations can be provided along second axis which is different from the first axis. Data for each of the signals
10 within at least one portion of the first information may include data for a plurality of depths within the sample. Second information associated with contrast data of at least one portion of an image for the at least one sample can be produced as a function of the first information.

In yet another exemplary embodiment of the present invention, further
15 apparatus and method can provided. For example, at least one first electro-magnetic radiation can be received, and at least one second electro-magnetic radiation within a solid angle can be forwarded to a sample. The second electro-magnetic radiation may be associated with the first electro-magnetic radiation. At least two of a plurality of third electro-magnetic radiations may be simultaneously received from the sample
20 which is associated with the second electro-magnetic radiation, and at least one portion of the third electro-magnetic radiations may be provided outside a periphery of the solid angle. An interference between the at least two of the third radiations and at least one fourth radiation associated with the first radiation may be detected.

Information associated with the sample can be obtained as a function of at least one depth within the sample based on the interference.

These and other objects, features and advantages of the present invention will become apparent upon reading the following detailed description of embodiments of the invention, when taken in conjunction with the appended claims.

BRIEF DESCRIPTION OF THE DRAWINGS

Further objects, features and advantages of the present invention will become apparent from the following detailed description taken in conjunction with the accompanying figures showing illustrative embodiments of the present invention, in which:

Figure 1 is a block diagram of a conventional apparatus for performing Optical Coherence Microscopy (“OCM”);

Figure 2 is a block diagram of a conventional apparatus for performing path length encoded angular compounding for reducing speckle in Optical Coherence Tomography (“OCT”);

Figure 3 is a block diagram of a conventional OCT apparatus for performing speckle reduction;

Figure 4 is a block diagram of a conventional OCT apparatus for performing array detection for speckle reduction;

Figure 5(a) and 5(b) are block diagrams of conventional apparatus for performing angle-resolved low-coherence interferometry;

Figures 6(a) and 6(b) are block diagrams of further conventional apparatus for performing the angle-resolved low-coherence interferometry;

Figure 7 is a schematic diagram of an exemplary embodiment of an angle-resolved FD-OCT system according to the present invention that employs a single-
5 dimensional detector array, with a rectangular, gray dashed region being oriented perpendicularly to the plane of the interferometer;

Figure 8 is a schematic diagram of an exemplary embodiment of a wavelength-swept laser source utilized the system shown in Figure 7;

Figure 9 is a schematic and operational diagram of a detection of the
10 interference another exemplary embodiment of an angle-resolved FD-OCT system according to the present invention that employs a two dimensional detector array for a simultaneous detection of wavelength and angle;

Figure 10 is a schematic and operational diagram of imaging optics providing within a further exemplary embodiment of an angle-resolved FD-OCT system
15 according to the present invention that can be compatible with endoscopic probes;

Figure 11(a) is a two-dimensional image of a tissue phantom obtained with the exemplary embodiments of the angle-resolved FD-OCT system according to the present invention for averages across one exemplary angular sample;

Figure 11(b) is another two-dimensional image of the tissue phantom obtained
20 with the exemplary embodiments of the angle-resolved FD-OCT system according to the present invention for averages across 400 angular samples;

Figure 12(a) is a graph of an angular distribution obtained from one resolution element within a tissue phantom in accordance with an exemplary embodiment of the present invention;

Figure 12(b) is a graph of an angular distribution obtained from one resolution
5 element using corresponding normalized cross-correlation function in accordance with an exemplary embodiment of the present invention;

Figure 13A is an image of an exemplary esophageal tissue obtained from compounding one angular sample, with an arrow pointing to a thin scattering layer within the epithelium;

10 Figure 13B is an image of an exemplary esophageal tissue obtained from compounding three angular sample, with the arrow pointing to a thin scattering layer within the epithelium;

Figure 13C is an image of an exemplary esophageal tissue obtained from compounding thirty (30) angular samples, with the arrow pointing to a thin scattering
15 layer within the epithelium; and

Figure 13C is an image of an exemplary esophageal tissue obtained from compounding four hundred (400) angular samples, with the arrow pointing to a thin scattering layer within the epithelium.

Throughout the figures, the same reference numerals and characters, unless
20 otherwise stated, are used to denote like features, elements, components or portions of the illustrated embodiments. Moreover, while the subject invention will now be described in detail with reference to the figures, it is done so in connection with the illustrative embodiments. It is intended that changes and modifications can be made

to the described embodiments without departing from the true scope and spirit of the subject invention as defined by the appended claims.

DETAILED DESCRIPTION OF EXEMPLARY EMBODIMENTS

EXEMPLARY PRINCIPLE OF ANGLE-RESOLVED FD-OCT

5 Angle-resolved FD-OCT is described herein below in a context of Fourier-Domain OCT. For example, in FD-OCT, the interference between reference light and the light backscattered from the imaging sample can be measured in the frequency domain in order to obtain the depth-resolved reflectance of a turbid, semi-turbid, or transparent medium. Electro-magnetic radiation (e.g., light, laser beam, etc.) of the
10 input light source can be split into a reference beam and a sample beam. The sample beam light may be directed to the sample to be imaged, and backscattered light from the sample may be interfered with reference beam light. In the case of angle-resolved FD-OCT, the reference beam can be spatially expanded such that it can be made larger in a cross-sectional area than the cross-sectional area of the sample beam in
15 order to allow for the interference with a range of backscattering angles beyond those subtended by the incident sample beam. The interference between the reference beam and the backscattered light can be measured using, e.g., a detector array, which may consist of (i) detectors integrated onto a single integrated circuit element, and/or (ii) individual detectors provided together in space. The angular dependence of the
20 detected backscattered light with respect to the incident beam may be encoded in the spatial domain, as the distribution of light intensities along at least one dimension of the detector array. The wavelength dependence of the interfered light may be measured, and Fourier analysis axial reflectivity profiles corresponding to different ranges of backscattering angles can be obtained.

For example, the interference signal S_i detected by an i th pixel of the detector array as a function of the frequency of laser light ν_n can be given by the following proportionality expression:

$$S_i(\nu_n) \propto P(\nu_n) \sqrt{\gamma_{r,i}(\nu_n) \gamma_{s,i}(\nu_n)} \int_0^\infty \sqrt{R(z)} \cos(4\pi\nu_n z/c + \phi(z)) dz \quad (1)$$

5 where $P(\nu_n)$ is the total power of the source. $R(z)$ and $\phi(z)$ are the amplitude and phase terms of the reflectance profile, respectively. An axial distance z may be expressed as a relative distance, with $z = 0$ corresponding to zero optical path difference between the sample and reference arms. The amount of the sample arm and reference arm electro-magnetic radiation (e.g., light) that reaches pixel i ,
 10 expressed as fractions of $P(\nu_n)$ can be denoted $\gamma_{s,i}$ and $\gamma_{r,i}$, respectively. The reflectivity profile $R(z)$ can be obtained as the Discrete Fourier Transform of the sampled interference signal along the dimension i :

$$\sqrt{R(z)} \propto \text{DFT}(S_i) \quad (2)$$

15

EXEMPLARY PRINCIPLE OF SPECKLE REDUCTION USING ANGLE-RESOLVED FD-OCT

Speckle results from distortions of the backscattered wavefront, which are likely caused by low-angle multiple forward scattering and diffuse multiple backscattering from closely separated refractive index heterogeneities. Angular compounding techniques are generally obtained from an observation that as a result of this interference, fields originating from different backscattering angles are de-correlated. By averaging the signals from different scattering angles incoherently, e.g., averaging of the magnitude of the reconstructed reflectance profiles, a reflectance signal with reduced speckle can be obtained.

The speckle signal-to-noise ratio (“SNR”) can be a measure of the speckle reduction, as the ratio of the mean to the square-root of the variance of pixel intensities within a medium with homogenous scattering properties:

$$\text{SNR} = \frac{\langle S_k \rangle}{\sqrt{\langle (S_k - \langle S_k \rangle)^2 \rangle}}, \quad (3)$$

where the angular brackets denote an average over a collection of pixels indexed by k . The speckle SNR can be a normalized measure of the variance of the signal obtained from a homogenous sample. As such, the speckle SNR may differ from the system sensitivity, which can be defined without the presence of speckle as the minimum detectable reflectance. For the exemplary angular compounding method, the SNR may increase proportionally to the square-root of the number of uncorrelated, incoherent averages, N :

$$\text{SNR}(N) = \text{SNR}(1)\sqrt{N}. \quad (4)$$

An extent to which the SNR can be increased by angular compounding may therefore be dependent on the level of angular decorrelation. In general, higher levels of decorrelation for OCT sample volumes containing large numbers of scatterers can be obtained, as well as those at large optical depths. In comparison, sharp interfaces and scatterers with dimensions that are similar to those of the sample volumes are likely to indicate a small amount of contrast enhancement from angular compounding.

PRINCIPLE OF EXTRACTION OF PARAMETERS FROM ANGULAR BACKSCATTERING DISTRIBUTIONS FOR IMAGE CONTRAST

The angular backscattering patterns of light, which may be measured by the angle-resolved FD-OCT methods and systems, can contain information about the scatterer size and the density of the imaging sample. This information may be relevant in, e.g., a clinical imaging context in order to distinguish between different regions of tissue that have very similar scattering properties that may be used in optical methods that measure the reflectance of light that is backscattered within a single angular range. Image contrast measures can be generated from angular backscattering distributions at each pixel, and such measures can be spatially smoothed, and/or image contrast measures can be generated from spatially smoothed angular backscattering distributions.

ANGLE-RESOLVED FOURIER-DOMAIN OCT

The FD-OCT techniques of SD-OCT and OFDI systems and method can measure a discrete spectral interference, and may differ in the implementation of this measurement. The OFDI systems and methods can use a wavelength-swept source to record the interference as a function of time, whereas the SD-OCT systems and methods may generally use a spectrometer to image interference spectra onto a detector array or a portion of an array.

Figure 7 shows a schematic diagram of an exemplary embodiment of the angle-resolved FD-OCT imaging system in accordance with the present invention. This exemplary system can include the following modules: a wavelength-swept source 705, an interferometer 707, and an acquisition camera 765 with corresponding electronics 785. For example, the laser output can be directed to the optical coupler 710 which may split the light into two arms of the interferometer 707. A collimated light provided from a reference arm collimator 725 may be incident on a cylindrical lens telescope with elements 735, 740, 745, and this telescope can which expand the beam in the dimension of the line-scan camera 765. A free-space coupler of variable length 712 can be placed within the reference arm before the collimator 725 to facilitate reference arm length adjustments. The collimated light from the sample arm collimator 730 can be directed through a linear polarizer 755 and the beam splitter 750, where such light may be incident on imaging optics 770, 775 which focus the light on a sample 780.

Polarization controllers 715, 720 provided before the collimators 725, 730, respectively, can be positioned to maximize the fringe modulation across the frequency range of the wavelength-swept source 705. The imaging optics 770 and 775 consists of a galvanometer mirror 770 with its axis parallel to the plane of the interferometer 707 and perpendicular to the beam which is incident upon it from the beam splitter 750, and a focusing lens 775 that is placed one focal length from the sample 780. The incident beam contacts the horizontal and vertical centers of the galvanometer mirror 770. The light back-reflected from the sample 780 can pass back via the mirror 770 and the focusing lens 775, and may subsequently interfere with the reference beam at the beam splitter 750. The interfered light may be incident on a cylindrical lens 760 which focuses the light onto the line-scan camera 765. The light

from a He-Ne laser 700 can be injected into the fiber coupler 710, and may act as a guide beam during the imaging procedure.

The signals from the line-scan camera 765 can be directed toward analog-to-digital (A-D) input ports of a data acquisition (“DAQ”) board 785. For example, in a
5 time period corresponding to one a-line, the DAQ board 785 can obtain m data points from n exposures, where m may be the number of detectors in the line scan camera 765, and n can be the number of frequencies sampled per a-line. The a-line acquisition rate can be determined as the quotient of the line scan camera readout rate and n . The readout from the DAQ board 785 may be synchronized to the frequency-
10 swept laser source 705 using, e.g., TTL trigger signals by the line-scan camera 765 at the beginning of each readout phase.

As shown in the diagram of Figure 8, the exemplary embodiment of the wavelength-swept source can be constructed as a ring-cavity laser with a semiconductor optical amplifier (“SOA”) 845 as the gain element and a galvanometer
15 mirror filter 800 that may include a galvanometer mirror 802, a telescope 805, 810, a diffraction grating 815, and a fiber collimator 820. Two polarization controllers 825, 840 can be provided to optimize a laser polarization and output coupler 835 which thus provides the laser output. The output coupler 835 can nominally split the light approximately equally between the output port 836 and the laser port 837. An optical
20 circulator 830 may direct light from the laser port 837 to the galvanometer mirror filter 800 via the polarization controller 840, and can direct the light returning from the galvanometer mirror filter 800 back to the SOA 845 via the polarization controller 825. As the galvanometer mirror 802 rotates, the wavelength reflected from the

galvanometer mirror filter 800 generally changes. An optical isolator 850 can be used to separate the laser from the rest of the exemplary system.

2D Detection for Resolution of Azimuthal and Polar Angles

According to a second exemplary embodiment of the present invention, the
5 detection of the interfered light can be performed using a two dimensional array of detectors, with both dimensions corresponding to the angular distribution of backscattered light. The light incident on the sample may be provided by a wavelength-tunable, narrow line-width source. The light backscattered from the imaging sample is interfered with a reference beam that has been expanded along two
10 spatial dimensions. Each detector array element can correspond to a unique range of polar and azimuthal angles of the backscattered light. By sweeping the laser across its tuning range, while acquiring readouts of the detector array, a vector for each discrete azimuth-polar angular pair can be obtained. Fourier-domain optical coherence tomographic reconstruction techniques may be applied the vectors, which can
15 generate depth-resolved reflectance profiles. By scanning the beam across the sample or moving the sample relative to the beam while acquiring readouts of the array, angle-resolved reflectance profiles for different locations on the tissue may be obtained. These profiles can be combined to form two- or three-dimensional cross-sectional reflectance images.

20 2D Detection for Simultaneous Resolution of Angle and Wavelength

According to a third exemplary embodiment of the present invention, a
detection of the interfered light can be performed using, e.g., a two dimensional array of detectors, with one dimension corresponding to wavelength, and the other to the angle of the backscattered light, as shown in the operational and block diagram of
25 Figure 9. The light incident on the sample may be provided by a broadband source.

The light backscattered from the sample can be interfered with a reference beam that has been expanded along one spatial dimension, and this dimension can correspond to the angle of the backscattered light. The interfered light 900 may be incident on a diffraction grating 905, which can separate light along another dimension
5 corresponding to wavelength. Subsequently, this separated light 910 can be incident on the two-dimensional detector array 915. Along each one-dimensional portion of the detector array readout which corresponds to a particular backscattering angular range, Fourier-domain optical coherence tomographic reconstruction techniques can be applied to the interference spectrum, thereby providing a depth-resolved
10 reflectance profile. By scanning the beam across the sample, or moving the sample with respect to the beam while acquiring readouts of the array, the angle-resolved reflectance profiles for different points on the tissue may be obtained. These profiles can be combined to form two- or three-dimensional cross-sectional reflectance images.

15 *Fiber-Bundle Optical Probe*

A fourth exemplary embodiment suitable for applications using small probe geometries in accordance with the present invention can be used with a fiber bundle, as shown in the operational and block diagram of Figure 10. According to this exemplary embodiment, an array of optical fibers 1025 can be used to transmit and
20 receive the light to and from an imaging sample 1000. One or more fibers in the array 1025 can be designated as “delivery fibers,” through which light 1010 may be transmitted to and received from the sample 1000. Each fiber in the array 1025 can correspond to a unique, narrow range of angular backscattering angles. Lenses placed before the fibers 1020 may serve to enhance the amount of light collected by each
25 fiber. A lens 1015 placed in front of the lenses 1020 serves to focus light onto the

sample 1000, and to collimate light backscattered from the sample 1000 prior to the collection by the lenses 1020.

Polarization Sensitive Angle-Resolved FD-OCT

Polarimetric measurements in the context of optical coherence tomography
5 may be useful for spatially resolving birefringence in biological tissue. According to a fifth exemplary embodiment according to the present invention, polarimetric measurements can be performed by one or more of the following:

- 10 a) varying the polarization of the light prior to the receipt thereof at the interferometer, and by fixing the polarization state of the reference arm and/or the sample arm;
- b) varying the polarization of only the sample beam as a function of time;
- c) varying the polarization of only the reference beam as a function of time;
- 15 d) varying the polarization state of one or more parts of the reference beam as a function of space, such that there may be at least two distinct parts of the reference beam that differ in the polarization state;
- e) varying the polarization state of one or more parts of the
20 backscattered light as a function of space prior to interference with the reference beam, such that there may be at least two distinct parts of the sample beam that differ in the polarization state;
- f) varying the polarization state of one or more parts of the interfered
25 distinct parts that differ in the polarization state.

Using the exemplary techniques (a), (b) and/or (c), the birefringence maps of the sample can be obtained by comparing a-lines received at different times, such that the polarization states from which they originated are likely different. Using the exemplary techniques (d), (e) and/or (f), the birefringence maps of the sample can be
5 obtained by comparing a-lines obtained from different backscattering angular ranges such that the polarization states from which they originated are likely different.

Particle Sizing

The angular frequency content obtained from the angle-resolved FD-OCT system and/or method can be analyzed using a computational framework of Mie
10 scattering, provided that the deviations of the beam from planar waves can be accounted for in the analysis. In particular, as the angular scattering distributions which can originate from spherical dielectric scatterers may be determined using the Mie theory, the inverse problem of determining the size distributions of the scatterers from the angular scattering distributions can be performed. The Mie scattering
15 analyses of angular backscattering distributions can enable a measurement of scatterer distributions within epithelial tissues, which may be correlated with dysplastic transitions that precede cancerous lesions.

Angular Decorrelation

Another method of processing angular backscattering distributions acquired
20 from angle-resolved FD-OCT involves analysis of their angular frequency content. Image contrast measures include the angular frequency bin with maximum power and the width of the peak with the highest power. Analysis of the power-spectral density of the angular backscattering distributions is equivalent to analysis of the auto-correlation function by the Wiener-Kinchine theorem. The normalized auto-
25 correlation function C can be provided by:

$$C_i = \frac{\sum_j (S_j - \langle S_j \rangle)(S_{j-i} - \langle S_j \rangle)}{\sum_j (S_j - \langle S_j \rangle)^2}. \quad (5)$$

where j and i can be angular indexes. For example, the width of the central lobe of the autocorrelation function, measured relative to the first minimum, can indicate the extent of the correlation between successive angular samples. This exemplary width
 5 can be determined for each pixel of a cross-sectional image obtained using the angle-resolved FD-OCT system and method, thus providing an image with the contrast for the de-correlation level of the angular backscattering distributions.

EXAMPLE

The exemplary embodiment of the system and method according to the
 10 present invention which can be used for reducing speckle was verified by the following experiment. Two-layer tissue phantoms were constructed from aqueous agar gel (0.5% agar by weight) and polymer microspheres of diameter 0.3 mm (Duke Scientific). The phantoms were contained in silicone isolators (Sigma). An initial scattering layer with an approximate depth of 2 mm was formed. A second scattering
 15 layer, designed to have a lower scattering coefficient than the first, was formed on top of the first and had an approximate depth of 450 mm. By analyzing the exponential signal attenuation with respect to depth, the total scattering coefficients were estimated to be 24 cm⁻¹ and 12 cm⁻¹ for the first and second layers, respectively.

The two-dimensional image generated from a single angular sample shows
 20 significant speckle, as shown in Figure 11(a), in which the boundary between the two layers is not clearly visible. Speckle is greatly reduced in the angularly compounded image, with the boundary between the two layers clearly visible, as shown in Figure 11(b). By a qualitative inspection, the resolution in the image in Figure 11(b) is not

likely to be significantly lower than that of the image of Figure 11(a). Graphs of exemplary representative angular distributions obtained from a point that is 500 mm below the surface of the phantom and the corresponding autocorrelation function are shown in Figures 12(a) and 12(b).

5 The effects of angular compounding are striking when applied to esophagus tissue, as shown in the images of Figures 13A-13D. These images were obtained from a swine *ex vivo*, and the imaging sample was lightly compressed by a coverslip to enhance the visibility of the layers underlying the epithelium. In particular, as shown in Figure 13A, the image generated from a single angular sample is
10 qualitatively similar to that obtained by a state-of-the art conventional OFDI system, e.g., in terms of the features that are resolved and the graininess resulting from speckle. In this exemplary image, a scattering layer within the epithelium is only faintly apparent (see arrow). With three compounded angles as shown in the image of Figure 13B, the level of speckle reduction is such that this layer can be resolved only
15 in certain parts of the image. With 30 or more angular averages as shown in the images of Figures 13C and 13D, the scattering layer clearly resolved across the length of the image. Similar increases in detail afforded by angular compounding are seen within the regions of lamina propria and submucosa underlying the epithelium.

 The foregoing merely illustrates the principles of the invention. Various
20 modifications and alterations to the described embodiments will be apparent to those skilled in the art in view of the teachings herein. Indeed, the arrangements, systems and methods according to the exemplary embodiments of the present invention can be used with any OCT system, OFDI system, spectral domain OCT (SD-OCT) system or other imaging systems, and for example with those described in International Patent

Application PCT/US2004/029148, filed September 8, 2004, U.S. Patent Application No. 11/266,779, filed November 2, 2005, and U.S. Patent Application No. 10/501,276, filed July 9, 2004, the disclosures of which are incorporated by reference herein in their entireties. It will thus be appreciated that those skilled in the art will be able to devise numerous systems, arrangements and methods which, although not explicitly shown or described herein, embody the principles of the invention and are thus within the spirit and scope of the present invention. In addition, to the extent that the prior art knowledge has not been explicitly incorporated by reference herein above, it is explicitly being incorporated herein in its entirety. All publications

5

10

referenced herein above are incorporated herein by reference in their entireties.

WHAT IS CLAIMED IS:

1. An apparatus comprising:
 - at least one first arrangement configured to receive at least one first
5 electro-magnetic radiation, and forward at least one second electro-magnetic radiation
within a solid angle to a sample, wherein the at least one second electro-magnetic
radiation is associated with the at least one first electro-magnetic radiation, wherein
the at least one first arrangement is configured to receive a plurality of third electro-
magnetic radiations from the sample which is associated with the at least one second
10 electro-magnetic radiation, and wherein at least one portion of the third electro-
magnetic radiations is provided outside a periphery of the solid angle; and
 - at least one second arrangement configured to simultaneously detect
signals associated with each of the third electro-magnetic radiations, wherein the
signals are associated with information for the at least one sample at a plurality of
15 depths thereof, and wherein the at least one second arrangement is capable of
determining the depths using at least one of the third electro-magnetic radiations
without a need to utilize another one of the third electro-magnetic radiations.
2. The apparatus according to claim 1, further comprising at least one third
20 arrangement configured to detect an interference between the at least two of the third
radiations and at least one fourth radiation associated with the at least one first
radiation, and obtaining information associated with the sample as a function of the
depths within the sample based on the interference.

3. The apparatus according to claim 1, further comprising at least one third arrangement configured to provide data associated with at least one of birefringence properties, spectroscopic properties, motion, angular back-scattering properties or elastic properties of at least one portion of the sample as a function of the signals.

5

4. The apparatus according to claim 1, further comprising at least one third arrangement capable of generating at least one image of at least one portion of the sample as a function of the signals.

10 5. The apparatus according to claim 4, wherein the at least one third arrangement is further configured to provide data associated with at least one of birefringence properties, spectroscopic properties, motion, angular back-scattering properties or elastic properties of at least one portion of the sample as a function of the signals.

15 6. The apparatus according to claim 5, wherein the data is contrast data associated with the at least one image.

7. The apparatus according to claim 1, further comprising at least one third arrangement configured to provide data associated with scattering characteristics of at
20 least one portion of the sample as a function of a combination of the signals.

8. The apparatus according to claim 1, wherein the at least one second arrangement is capable of determining the depths using a single one of the third electro-magnetic radiations.

25

9. A method for detecting signals, comprising:
- receiving at least one first electro-magnetic radiation;
 - forwarding at least one second electro-magnetic radiation within a solid angle to a sample, wherein the at least one second electro-magnetic radiation is
 - 5 associated with the at least one first electro-magnetic radiation;
 - receiving a plurality of third electro-magnetic radiations from the sample which is associated with the at least one second electro-magnetic radiation, wherein at least one portion of the third electro-magnetic radiations is provided
 - outside a periphery of the solid angle;
 - 10 simultaneously detecting the signals associated with each of the third electro-magnetic radiations, wherein the signals are associated with information for the at least one sample at a plurality of depths thereof, and
 - determining the depths using at least one of the third electro-magnetic radiations without a need to utilize another one of the third electro-magnetic
 - 15 radiations.
10. An apparatus for providing data associated with at least one sample, comprising:
- at least one first arrangement configured to receive first information
 - 20 associated with signals for a plurality of electro-magnetic radiations provided from the at least one sample, wherein at least first one of the electro-magnetic radiations being provided along a first axis, and at least second one of the electro-magnetic radiations being provided along second axis which is different from the first axis,
 - wherein data for each of the signals within at least one portion of the first information
 - 25 includes data for a plurality of depths within the at least one sample; and

at least one second arrangement configured to produce second information associated with contrast data of at least one portion of an image for the at least one sample as a function of the first information.

5 11. The apparatus according to claim 10, wherein the at least one portion of the signals is provided outside a periphery of the solid angle.

12. The apparatus according to claim 10, wherein the at least one second arrangement is capable of determining parameters of the at least one depth within the
10 sample using the first information.

13. The apparatus according to claim 10, wherein the at least one second arrangement is capable of determining the at least one depth using data associated with a single one of the signals.

15

14. The apparatus according to claim 10, further comprising at least one third arrangement capable of generating at least one image of at least one portion of the sample as a function of the second information.

20 15. The apparatus according to claim 14, wherein the at least one third arrangement is further configured to provide data associated with at least one of birefringence properties, spectroscopic properties, motion, angular back-scattering properties or elastic properties of at least one portion of the sample as a function of the second information.

25

16. The apparatus according to claim 15, wherein the data is contrast data associated with the at least one image.

17. The apparatus according to claim 10, further comprising at least one third
5 arrangement configured to provide data associated with scattering characteristics of at least one portion of the sample as a function of a combination of the signals.

18. A method providing data associated with at least one sample, comprising:
receiving first information associated with signals for a plurality of
10 electro-magnetic radiations provided from the at least one sample, wherein at least first one of the electro-magnetic radiations being provided along a first axis, and at least second one of the electro-magnetic radiations being provided along second axis which is different from the first axis, wherein data for each of the signals within at least one portion of the first information includes data for a plurality of depths within
15 the at least one sample; and
producing second information associated with contrast data of at least one portion of an image for the at least one sample as a function of the first information.

20 19. An apparatus comprising:
at least one first arrangement configured to receive at least one first electro-magnetic radiation, and forward at least one second electro-magnetic radiation within a solid angle to a sample, wherein the at least one second electro-magnetic radiation is associated with the at least one first electro-magnetic radiation, wherein
25 the at least one first arrangement is configured to simultaneously receive at least two

of a plurality of third electro-magnetic radiations from the sample which is associated with the at least one second electro-magnetic radiation, and wherein at least one portion of the third electro-magnetic radiations is provided outside a periphery of the solid angle; and

5 at least one second arrangement configured to detect an interference between the at least two of the third radiations and at least one fourth radiation associated with the at least one first radiation, and configured to obtain information associated with the sample as a function of at least one depth within the sample based on the interference.

10

20. The apparatus according to claim 19, wherein the at least one second arrangement is capable of determining the at least one depth based on the interference without a need to utilize another one of the third electro-magnetic radiations.

15 21. The apparatus according to claim 20, wherein the at least one second arrangement is configured to simultaneously detect signals associated with each of the third electro-magnetic radiations.

20 22. The apparatus according to claim 21, further comprising at least one third arrangement configured to provide data associated with at least one of birefringence properties, spectroscopic properties, motion, angular back-scattering properties or elastic properties of at least one portion of the sample as a function of the signals.

23. The apparatus according to claim 21, further comprising at least one third arrangement capable of generating at least one image of at least one portion of the sample as a function of the signals.
- 5 24. The apparatus according to claim 23, wherein the at least one third arrangement is further configured to provide data associated with at least one of birefringence properties, spectroscopic properties, motion, angular back-scattering properties or elastic properties of at least one portion of the sample as a function of the signals.
- 10
25. The apparatus according to claim 24, wherein the data is contrast data associated with the at least one image.
26. The apparatus according to claim 21, further comprising at least one third
15 arrangement configured to provide data associated with scattering characteristics of at least one portion of the sample as a function of a combination of the signals.
27. The apparatus according to claim 20, wherein the at least one second
20 arrangement is capable of determining the depths using a single one of the third electro-magnetic radiations.
28. A method for detecting signals, comprising:
receiving at least one first electro-magnetic radiation;

forwarding at least one second electro-magnetic radiation within a solid angle to a sample, wherein the at least one second electro-magnetic radiation is associated with the at least one first electro-magnetic radiation;

5 simultaneously receiving at least two of a plurality of third electro-magnetic radiations from the sample which is associated with the at least one second electro-magnetic radiation, wherein at least one portion of the third electro-magnetic radiations is provided outside a periphery of the solid angle;

detecting an interference between the at least two of the third radiations and at least one fourth radiation associated with the at least one first
10 radiation; and

obtaining information associated with the sample as a function of at least one depth within the sample based on the interference.

PRIOR ART

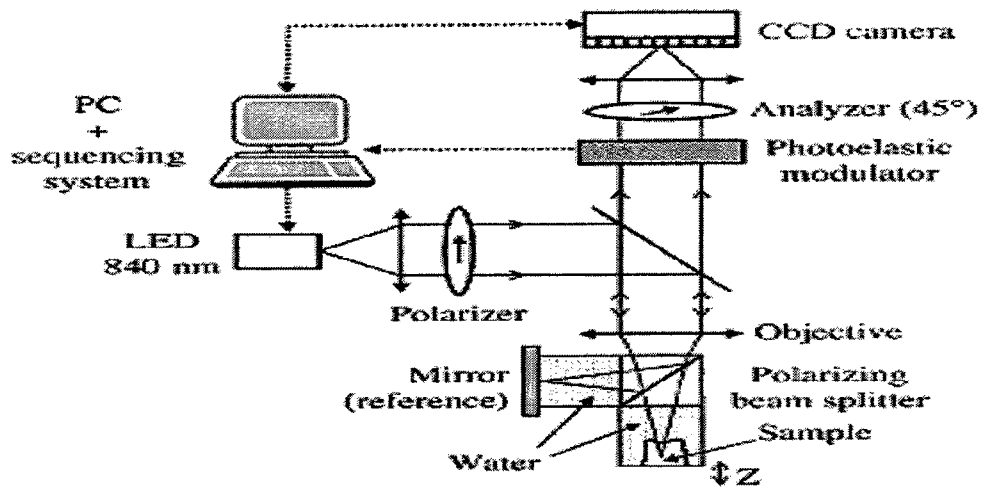

Figure 1

PRIOR ART

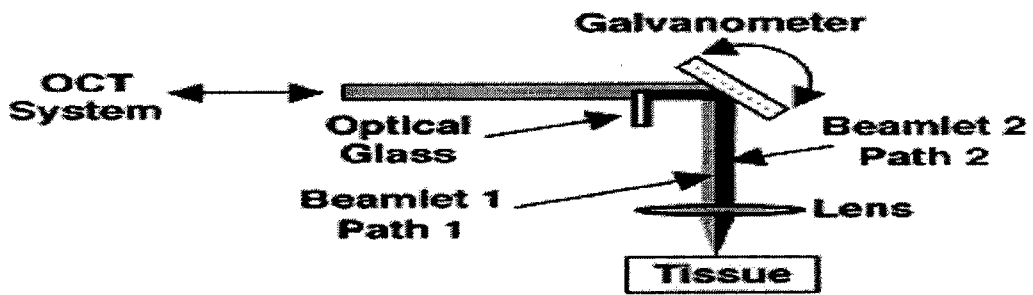

Figure 2

PRIOR ART

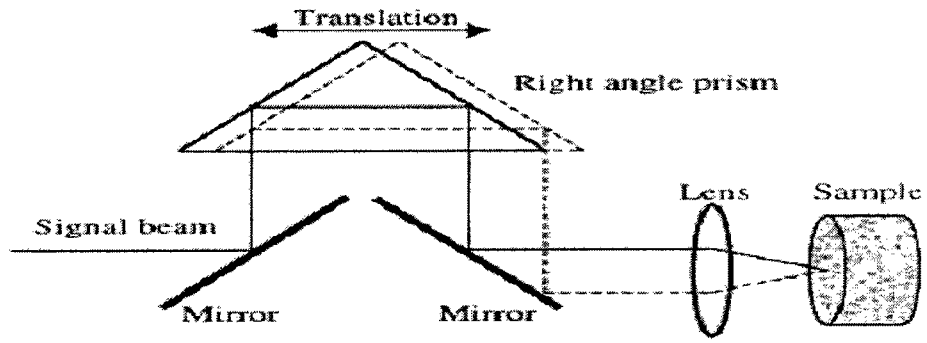

Figure 3

PRIOR ART

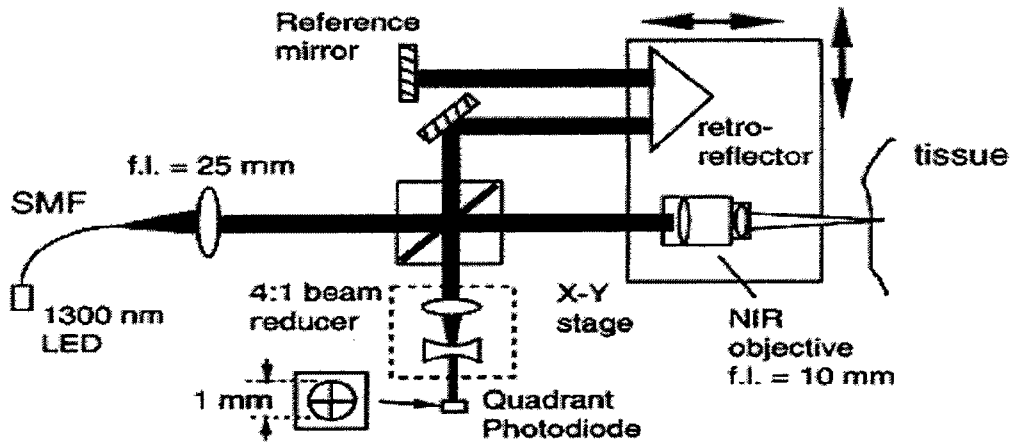

Figure 4

PRIOR ART

Figure 5(a)

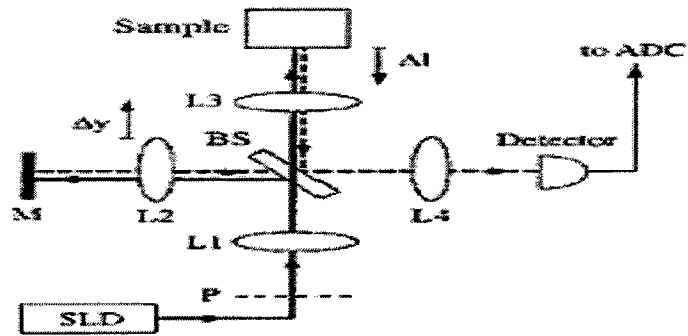

Figure 5(b)

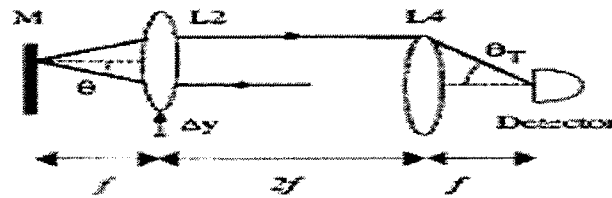

Figure 6(a)

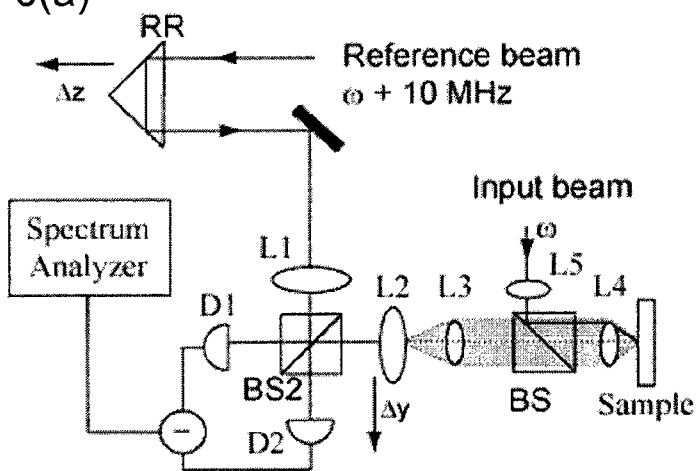
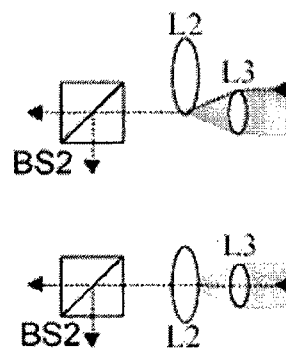

Figure 6(b)



PRIOR ART

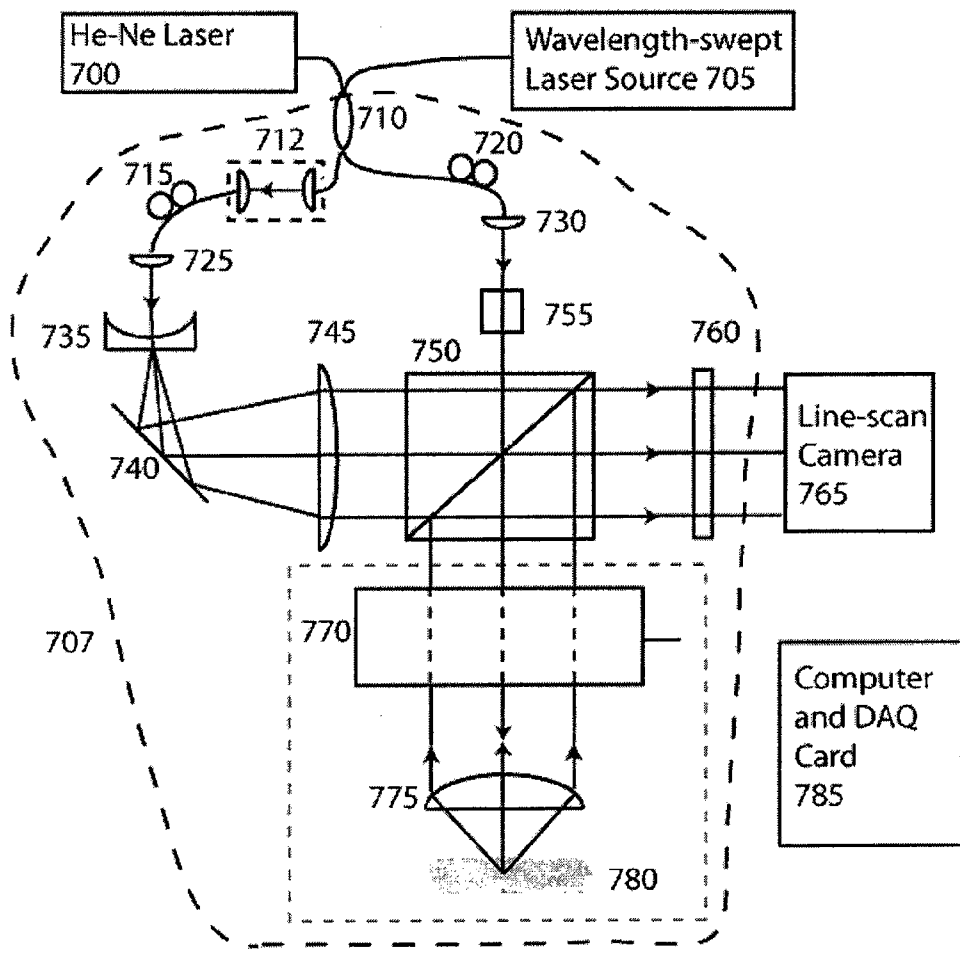

Figure 7

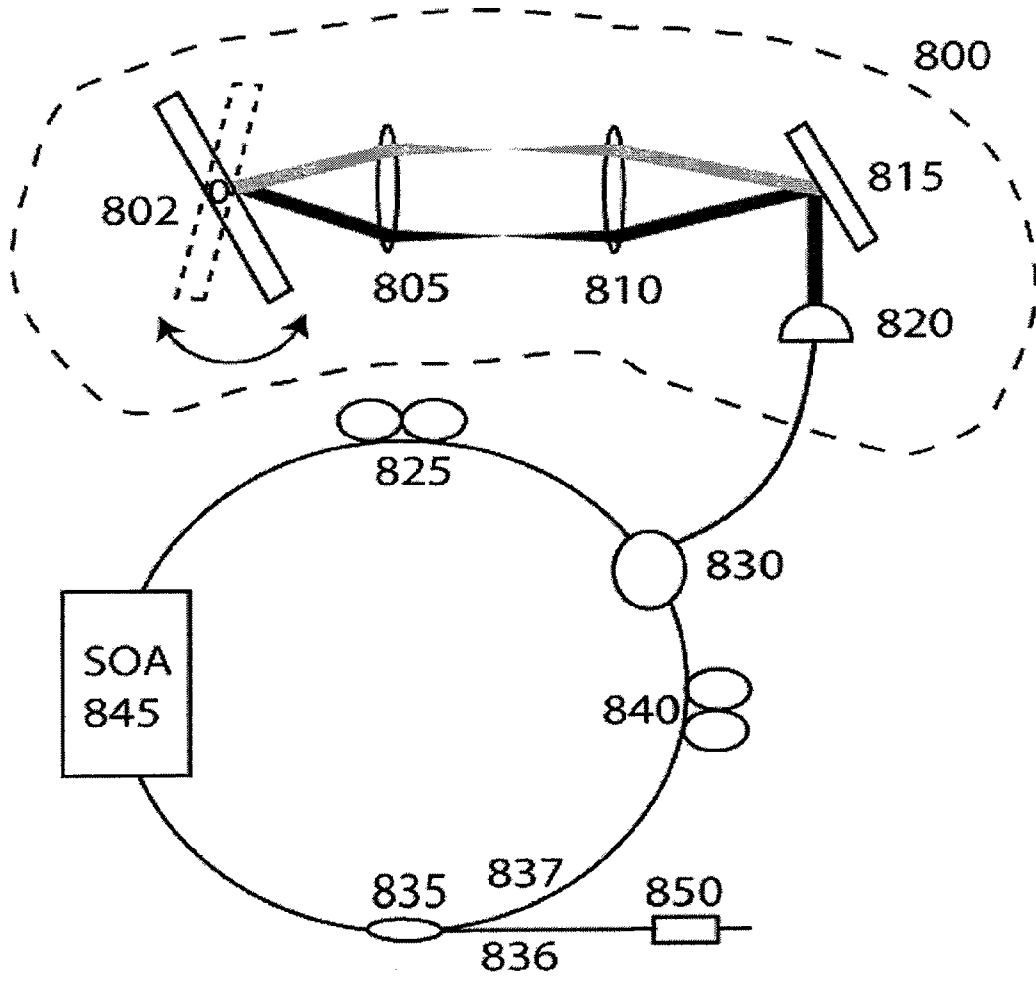

Figure 8

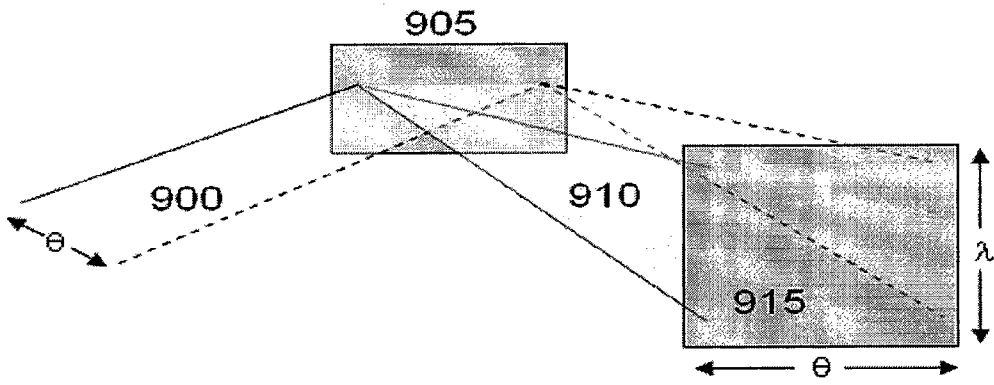

Figure 9

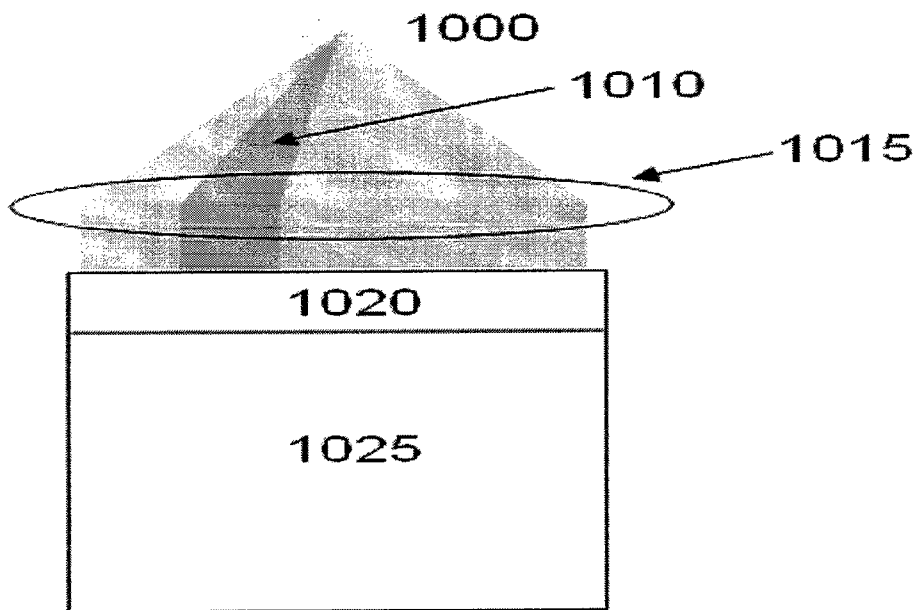

Figure 10

Figure 11(a)

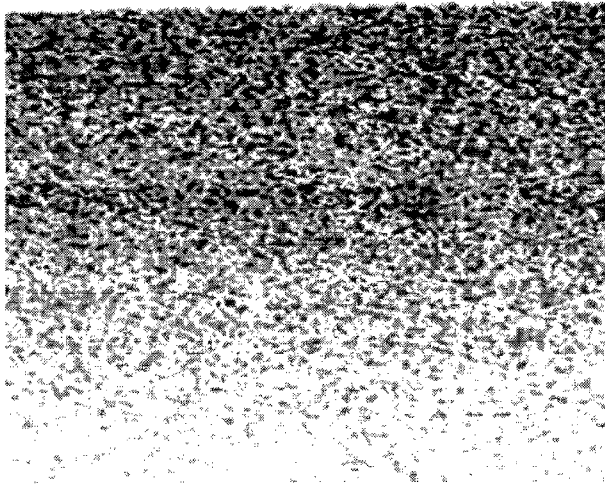

Figure 11(b)

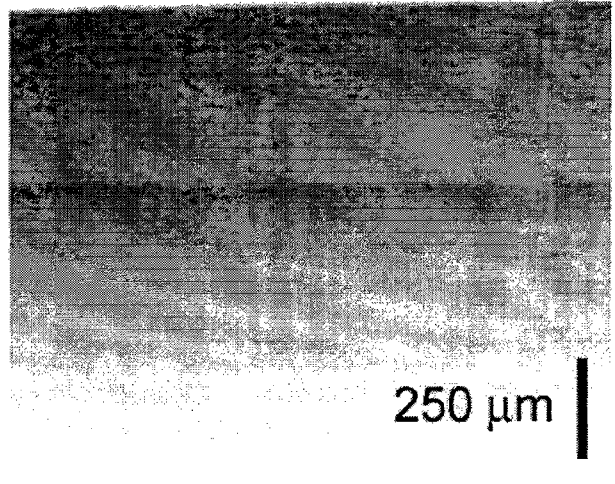

Figure 12(a)

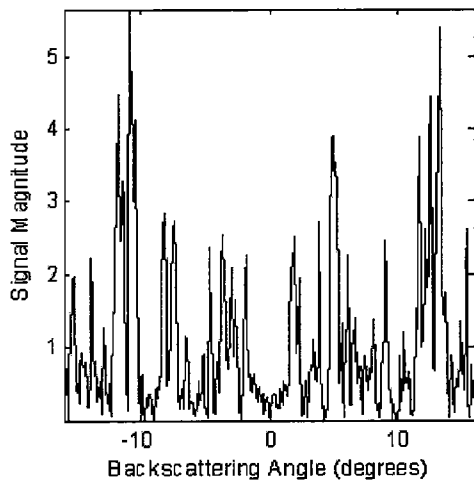
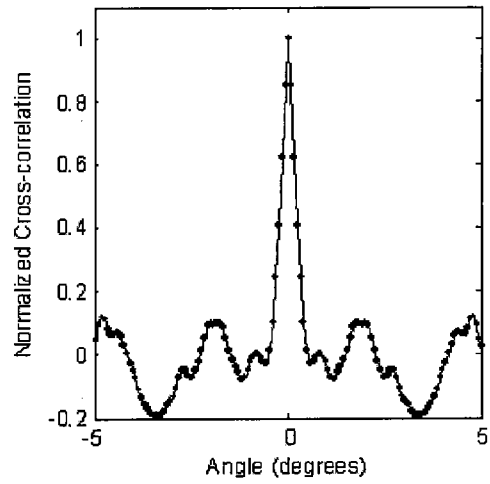

Figure 12(b)



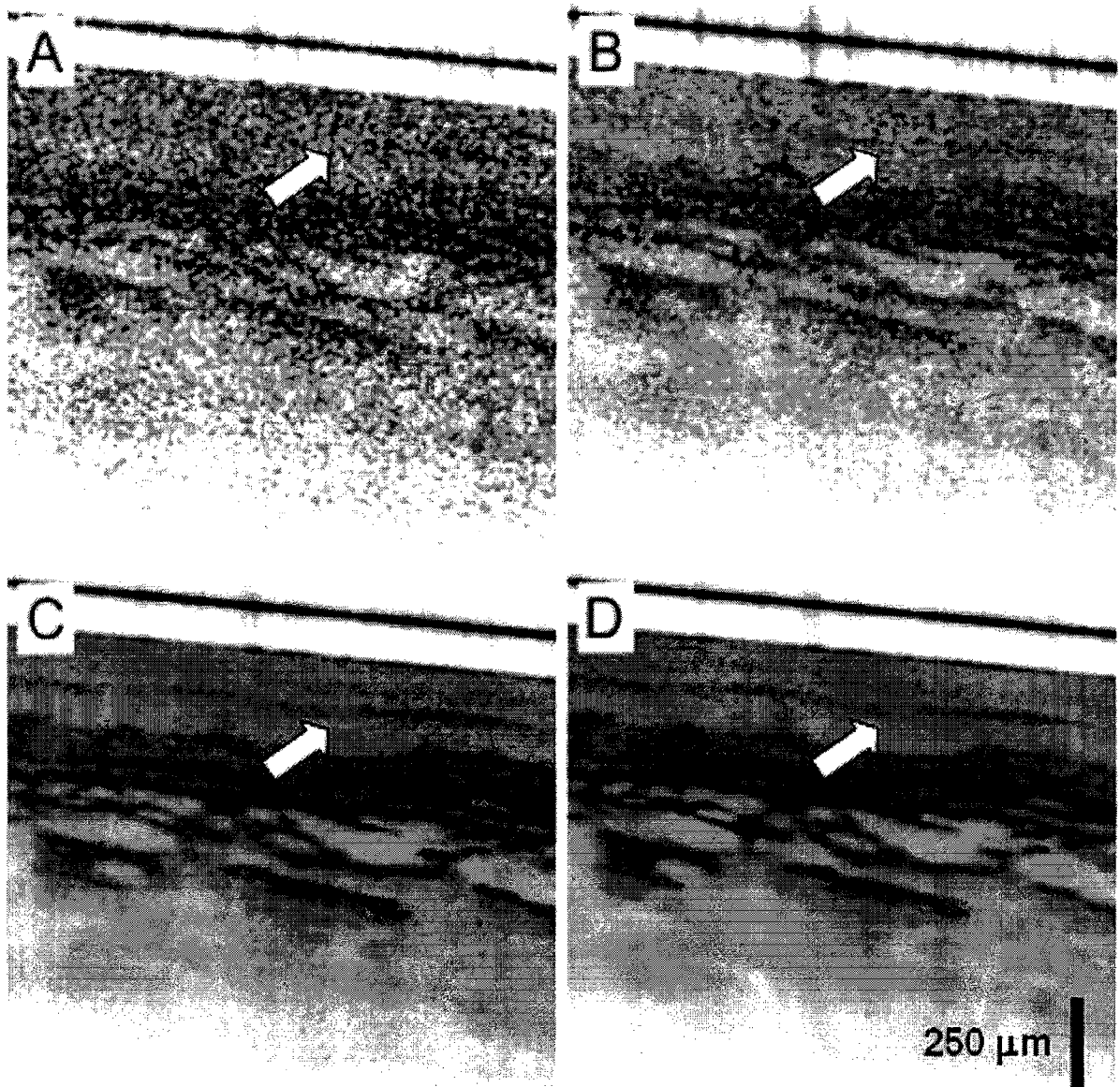

Figure 13