

(57) **Abrégé(suite)/Abstract(continued):**

fuel from the storage tank to the conduit and the dispensers, and a control connected to the pump-motor assembly for holding the fuel pressure in a preset range. Preferably the range is that required for efficient operation of a vapor recovery system, or other requirement by the EPA or by another agency, or by a service station operator. The control includes sensors which respond to the pressure in the conduits leading to the fuel dispensers. The sensors may comprise, for example, a pressure sensor in the conduit, or they may comprise power consumption sensors connected to the electrical power supply for the variable speed pump-motor assembly.

2180875

Abstract of the Disclosure

A pumping system for use in a fuel service station including one or more fuel dispensers, a fuel storage tank and conduits connecting the fuel dispensers with the tank. The pumping system comprises a variable speed pump-motor assembly for pumping fuel from the storage tank to the conduit and the dispensers, and a control connected to the pump-motor assembly for holding the fuel pressure in a preset range. Preferably the range is that required for efficient operation of a vapor recovery system, or other requirement by the EPA or by another agency, or by a service station operator. The control includes sensors which respond to the pressure in the conduits leading to the fuel dispensers. The sensors may comprise, for example, a pressure sensor in the conduit, or they may comprise power consumption sensors connected to the electrical power supply for the variable speed pump-motor assembly.

Field and Background of the Invention

This invention relates to pumping systems for service stations which dispense fuel such as gasoline into automotive fuel tanks.

5 Gasoline service stations normally include a number of fuel dispensers and storage tanks for the fuels. A pump-motor assembly is mounted in each tank and it pumps the fuel to a number of dispensers. Such a pumping system normally also includes
10 controls such as a leak detector (either mechanical or electronic) and fault detectors. The pump-motor assembly is a fixed speed type which is turned on when fuel is to be dispensed, in the absence of a leak or other fault condition.

15 Automatic leak detectors have come into common use. In recent years vapor recovery systems have also come into use in some areas and, in fact, in some areas they have been mandated. Vapor recovery systems (Stage II) are designed to capture fuel
20 vapor leaving an automotive fuel tank during filling and to conduct the vapor to the fuel storage tank or tanks.

As mentioned above, the prior art pumping systems include a fixed speed pump-motor assembly which
25 is either on or off, and such an arrangement has a number of disadvantages. Each pump-motor assembly supplies fuel to a number of dispensers, and the fuel pressure varies with the number of dispensers in use at a given time. If only one dispenser is in
30 use (nozzle open), the fuel pressure in the supply line typically is about 30-32 psi (pounds per square

inch) and the nozzle delivers about 10-14 gpm (gal-
lons per minute). If two dispensers are in use, the
pressure at both nozzles drops to about 25-28 psi
and the flow from each nozzle is about 8-10 gpm.
5 The pressure and the flow rate drop further as addi-
tional nozzles are opened. If the pressure is at
the high end of the range during fueling, there may
be problems with splash-back and hydraulic hammer-
ing. On the other hand, if the pressure is at the
10 low end, the time needed to fill a tank may be ex-
cessive.

Further, vapor recovery systems are most effi-
cient when the fuel flow rate is at an intermediate
value, and the current dispenser manufacturers state
15 that the flow rate should be between 8-10 gpm.
Further, the EPA regulations effective January, 1996
and January, 1998 state that the flow rate is to be
less than 10 gpm when dispensing. A high pump pres-
sure and pressure regulator valves could be used to
20 meet this requirement, but pumping systems are dif-
ferent and may require customized equipment and/or
adjustments.

Still further, leak detectors are most effi-
cient when the pressure is relatively high, but as
25 pointed out above, a high fuel pressure can produce
other problems.

It is therefore an object of the present inven-
tion to avoid the foregoing disadvantages by provid-
ing an improved pumping system including a variable
30 speed pump-motor assembly and controls therefor.

Summary of the Invention

A pumping system for use in a fuel service station including two or more fuel dispensers, a fuel storage tank and conduits connecting the fuel dispensers with the tank. The pumping system comprises a variable speed pump-motor assembly for pumping fuel from the storage tank to the conduit and the dispensers, and a control connected to the pump-motor assembly for holding the fuel pressure in a preset range during normal operation while fuel is being dispensed. Preferably the range is that required for efficient operation of a vapor recovery system or other EPA requirements. The control includes sensors which respond to the pressure in the conduits leading to the fuel dispensers. The sensors may comprise, for example, a pressure sensor in the conduit, or they may comprise power consumption sensors connected to the electrical power supply for the variable speed pump-motor assembly. A circuit may be provided for producing an initial fuel pressure boost for efficient operation of a leak detector, when the pump-motor assembly is turned on.

Brief Description of the Drawings

The invention will be better understood from the following detailed description taken in conjunction with the accompanying figures of the drawings, wherein:

Fig. 1 is a schematic diagram of the pumping system incorporating the invention;

- 4 -

Fig. 2 is a block diagram illustrating an embodiment of the invention;

Fig. 3 is a schematic diagram illustrating the embodiment of the invention shown in Fig. 2;

5 Fig. 4 is a curve illustrating the operation of the apparatus; and

Figs. 5, 6, and 7 are diagrams similar to Fig. 2 but illustrating additional embodiments of the invention.

10 Detailed Description of the Invention

Fig. 1 illustrates a portion of a gasoline service or filling station including a ground level dispenser 10 including a cabinet 11 a dispensing hose 12 and a dispensing nozzle 13. The service station further includes at least one fuel storage tank 14 which, as illustrated in Fig. 1, is usually located below ground surface level. Mounted within the tank 14 is a pump-motor assembly 16. The pump-motor assembly 16 includes a submerged turbine or centrifugal pump driven by an electric motor, the pump and the motor being mounted in a casing 17. The upper end of the assembly 16 is attached to a pipe 18 which both suspends the assembly 16 in the tank 14 and conveys pumped fuel 19. The upper end of the pipe 18 is connected to a manifold assembly 21, the manifold 21 also being connected by conduits 22 and 23 to the dispensers 10. The manifold 21, in this specific example, is mounted in a containment sump 24 which is normally covered by a cover 25 at the street level.

15
20
25
30

- 5 -

In the embodiment of the invention illustrated in Fig. 1, the system may further include a vapor recovery system including a vapor-pump 27 mounted in the dispenser 10 or near the manifold 21, for example, and a pipe 28 which conveys recovered vapor back to the storage tank 14. The system may still further include a leak detector 29 connected to the conduit 22.

While only one dispenser 10 is illustrated in Fig. 1, it should be understood that the typical service station includes a plurality of dispensers, and a plurality of pipes or conduits 23 lead from the conduit 22 to the various dispensers.

It should also be understood that a typical service station offers a number of grades and/or types of fuel and that each type or grade will have a separate storage tank. Consequently, more than one conduit 23 will lead to each of the dispensers 10.

In the typical operation of the system illustrated in Fig. 1, when a customer picks up the nozzle 13 and inserts it into the fuel tank of an automobile, truck, etc., and activates the dispenser with the dispenser switch, a control circuit turns on the pump-motor assembly 16. The leak detector 29 checks the system for leaks, and assuming there is no leak, fuel is delivered under pressure through the conduits 22 and 23 to the hose 12 and the nozzle 13. If two or more dispensers are operated simultaneously, the assembly 16 delivers fuel under pressure through the conduit 22 to all of the dispensers being operated. It an important feature of the

present invention that the quantity of fuel delivered by the pump-motor assembly 16 varies in accordance with the demand for fuel, the demand, of course, changing as a function of the number of
5 dispensers 10 in use at any given time. The fuel pressure in the conduits 22 and 23 is substantially constant and is independent of the flow demand. The speed of the assembly 16 is adjusted to meet the demand and to hold the pressure substantially constant.
10

With reference to Fig. 2, a fuel pressure transducer or sensor 31 is connected to the manifold 21 and senses the fuel pressure in the lines 22 and 23. An electric signal representing the pressure is
15 fed to a motor control and drive module 32 which also receives a set pressure signal from a pressure setting circuit 33. The circuit 32 may also be controlled entirely by a remote control system 33a. Thus the signal from the sensor 31 represents the
20 actual system fuel pressure and the signal from the sensor 33 represents the desired fuel pressure. The module 32 also receives AC power from a source 34 and it is connected to the pump-motor assembly 16 by a cable or power supply line 36.

25 The system shown in Fig. 2 further includes the leak detector 29 which may be a mechanical or an electronic type. While a variety of arrangements are available for use, in the specific example shown in Fig. 2, an electronic leak detector 29 responds
30 to the line pressure signal provided by the sensor 31, and its output is connected to the main system control 38, which may be in the console of the service station. The main control 38 or a leak detec-

tor controller is connected to the motor control 32 and shuts off electric power to the motor in the event of a leak. If a mechanical leak detector is provided, there may be no need for a pressure sensor or for a leak detector controller.

While a variety of well known prior art variable speed motors and electrical drives may be used, it is preferred that a DC link arrangement, having a construction well known to those skilled in the electric motor art, be provided as illustrated in Fig. 3. The pump-motor assembly 16 includes a submersible three-phase induction motor 41 connected by a mechanical coupling to a centrifugal or turbine-type fuel pump 42. The power supply 34 may be a single phase or three phase supply, at either 50 or 60 Hz. The supply is preferably between 200-250 volts AC, but other power supplies may be used. A converter 43 changes the AC voltage to a DC voltage on two lines 44 and 45 which are connected to the input of an inverter 47 that changes the DC voltage to three-phase AC in the power line 36. The inverter 47 includes banks of transistor switches, and control lines 48 carry pulse trains from a control unit 49 to the transistors for switching the transistors on and off to produce a three-phase supply for driving the motor 41.

The control unit 32 is responsive to the signal from the pressure sensor 31 which represents the pressure in the conduits 23, and the unit 32 controls the speed of the pump-motor assembly 16 to maintain the conduit pressure at a substantially constant value regardless of the flow rate of the fuel flowing in the lines 23 leading from the mani-

- 8 -

fold 21 to the dispensers. The flow volume may vary, of course, because the flow in each of the lines 23 may change and the number of dispensers simultaneously in use may change. If the speed of
5 the pump-motor assembly 16 were constant, the pressure would fall with an increase in the number of dispensers in use. However, in accordance with the present invention, the motor control assembly responds to a change in pressure and/or the flow demand in the manifold 21 and changes the speed of the
10 pump-motor assembly 16 to hold the fuel pressure at a substantially constant level regardless of the demand. While the foregoing statement is true for the most part, the control unit 49 preferably includes a limiting circuit which prevents the motor
15 speed from rising above a safe upper limit. Further, as will be described hereinafter, the system preferably further includes a circuit 51 (Fig. 3) for producing an initial pressure boost in the manifold at the time a mechanical leak detector is operating.
20

The control module 32 may respond to the pressure sensor 31 and include a pressure control circuit as described in the David M. Triezenberg
25 United States Patent No. 5,580,221 and titled MOTOR CONTROL CIRCUIT.

Instead, the control module 32 may respond to
30 the power supplied to the pump-motor assembly 16. A small size resistor 52 (Fig. 3) is connected in the DC line 45 and two leads 53 and 54 are connected across the resistor 52 and to the control unit 49.

The voltage across the resistor 52, of course, is representative of the DC current in the lines 44 and 45. Further, a voltage divider formed by two resistors 56 and 57 is connected across the lines 44 and 5 45. Two leads 54 and 58 are connected across the resistor 56 and to the unit 49, and the voltage across the lines 54 and 58 is representative of the voltage across the lines 44 and 45. Thus the resistors 52, 56 and 57, and the leads 53, 54 and 58 form 10 current and voltage sensors from which the power drawn by the pump-motor assembly 16 may be represented.

For a given design of a pump-motor assembly 16 operating with a known (or negligible) elevation head, the power consumption (from the lines 53, 54 15 and 58) and the motor speed (from the switching frequency on the lines 48) may be determined by tests for all combinations of pump outlet pressure and flow volume. A constant output pressure under 20 varying flow demand may be attained by adjusting the frequency (the motor speed) up or down as needed to maintain the correct relation of frequency and power consumption. Fig. 4 illustrates a constant pressure performance curve 50 for such a control unit and 25 pump-motor unit. Thus the speed-flow-pressure-watt characteristics are mapped out for a given pump-motor drive unit in a given installation, and these characteristics are then used to infer the pump outlet pressure and flow volume from known (mapped 30 out) motor speed and power consumption. The micro-controller 49A of the control unit 49 is then programmed to achieve a constant pressure output. Techniques for plotting the characteristics of a

pump-motor unit are well known to those skilled in this art.

With reference again to Fig. 1, the system further may include a vapor recovery arrangement which may, for example, be constructed as described in U.S. patent No. 5,040,577. In such a system, fuel vapor leaving a fuel tank of a vehicle during filling is returned through the hose 12 and the conduit 28 to the storage tank 14. The recovery of the vapor is most efficiently accomplished when the rate of flow of the fuel into the automotive fuel tank is in the range of approximately 8-10 gpm, and the pressure represented by the curve 50 produces this flow rate. The fuel flow rate at a given installation is a function of the line pressure, the nozzle 13 configuration, piping, etc. It is an important feature of the present invention that a flow rate in the 8-10 gpm range, at a given service station may be achieved by adjusting the system for the line pressure which produces the flow rate. Since the line pressure is held substantially constant as shown by the curve 50, this flow rate will then be maintained at all dispensers by automatically adjusting the pump speed and output as needed. The system pressure is adjusted by manually adjusting the pressure command 33.

Summarizing the operation of the system described above, if a mechanical leak detector 29 (which may have a conventional construction) is included in the system, the fuel conduits 23 are tested for a leak each time the pump-motor assembly 16 is turned on (and the fuel pressure in the conduits 23 is below 1-5 psi). The test for a leak

takes place within the initial 2 to 6 seconds of operation of the assembly 16. Assuming the conduit pressure is initially below 1-5 psi, the assembly 16 is turned on when fuel is to be dispensed and fuel pressure in the conduits 23 builds up to between 12 and 18 psi. The mechanical leak detector restricts the flow of fuel to the conduits 22 to less than 3 gallons per hour. If the mechanical leak detector does not sense a leak, it opens to the full flow position and fuel may then be dispensed from the dispenser(s).

In a system without the boost circuit 51, when the controller 32 and 33 are set to maintain the conduit pressure at less than approximately 35 psi, the mechanical leak detector may take longer than the initial 2 to 6 seconds to operate; if the controller is set to maintain the pressure at less than approximately 15 psi, the mechanical leak detector may not function properly at all. These problems are overcome in accordance with this invention because the boost circuit 51 is connected to the control 49 to sense the initial energization of the motor 41 and to activate the control 49 to produce an initial boost in motor speed for an initial 2 to 6 seconds. The boost circuit is preferably structured to make possible an adjustment at the point of installation, for the time length of the initial boost, to accommodate different leak detectors and other variables. Following the initial speed boost (and the consequent fuel pressure boost), the fuel pressure level is reset by the control 49 to maintain the pressure as set by the command 33 to maintain the flow rate of 8-10 gpm.

In a system including an electronic line leak detector 29 (Fig. 2), the system operation depends on the particular leak detector in use. In the event that an electronic line leak detector is included in the system, which could utilize the features of the variable speed pump-motor assembly 16 to increase or decrease the conduit pressure, the detector may be connected to the motor controller 32 through a serial connection. This arrangement would enable the detector to turn on or off the motor, or to run the motor to produce higher pressures, or to run the motor to produce different pressures for defined periods of time, or to provide any other function to enable the operation to be more efficient.

Fig. 5 illustrates a system generally similar to that of Figs. 1 to 3 but without the remote controls shown in Fig. 3. The motor control 32A includes voltage and current sensors as described above and controls the speed of the assembly 16A as a function of the power delivered to the assembly.

Fig. 6 also illustrates a system generally similar to that of Figs. 1 to 3 but without the remote controls. The pressure transducer 31B delivers a line pressure representative signal to the control 32B, which controls the motor speed to hold the pressure at a substantially constant level.

Finally, Fig. 7 shows a system similar to that of Fig. 5 but which includes a leak detector 37C. A pressure sensor 37D of the leak detector provides a pressure representative signal during the initial

period of operation of the pump-motor assembly 16C. If a leak is detected, the detector 37C shuts down the motor control and drive circuit in the module 32C and it signals the main system control or console 38C.

It will be apparent from the foregoing that a novel and useful pumping system has been provided. The system is operable to provide fuel at a nozzle pressure low enough to provide appropriate and not excessive flow rate to avoid splash back and hydraulic hammering, and at a pressure which is most efficient for operation of a vapor recovery system (Stage II). This pressure is substantially constant at all dispensers regardless of the number of dispensers in use. Further, the system easily accommodates other controls such as a leak detector, and it may include means for increasing the system pressure for a short interval.

A number of factors influence the pressure at a service station, including the size and length of the conduits; the type of dispenser and nozzle; the elevation difference between the supply tank and the nozzle; the type of vapor recovery system; the type of leak detector; and the presence of other components such as mechanical breakaways and swivels. At a given installation, the pumping system may have to be adjusted to achieve the desired pressure in view of the above factors, and adjustment may be made by setting the control 33 (Fig. 2).

- 14 -

What Is Claimed Is:

1. A pumping system for a fuel service station, the service station including at least one fuel storage tank, a plurality of fuel dispensers, and fuel flow conduits for conveying fuel from the storage tank to the dispensers, said pumping system comprising:

- a) a fuel dispensing hose and nozzle on each fuel dispenser for delivering fuel to a motor vehicle fuel tank in response to activation of independently-operable switches connected to each of such dispensers;
- b) a fuel pump;
- c) means for coupling said fuel pump to said conduits whereby said fuel pump is operable to pump fuel through said conduits to said dispensers;
- d) an electric motor connected to an electrical power source to drive said fuel pump;
- e) sensors connected to the power source for determining the power drawn by said electric motor and providing power representative signals; and
- f) electric means responsive to said signals for adjusting the speed of said motor to maintain the fuel pressure in said flow conduits at a

- 15 -

substantially constant pressure regardless of the fuel flow demand.

2. The fuel pumping system of claim 1 wherein said electric motor comprises a three-phase induction motor and said power source comprises:

- i) an ac power supply;
- ii) a converter circuit for rectifying the ac voltage output of said power supply to a dc voltage; and
- iii) an inverter circuit for changing said dc voltage to three phase ac voltages.

3. The fuel pumping system of claim 2 wherein said sensors for determining the power drawn by the electric motor are connected to said converter circuit.

4. The fuel pumping system of claim 1 further including a fuel pressure sensor in said fuel coupling means.

5. A pumping system for a fuel dispensing installation, the installation including at least one fuel storage tank, a plurality of fuel dispensers, and fuel flow conduits for conveying fuel from the storage tank to the dispensers, said pumping system comprising:

- a) a pump-motor assembly;
- b) means for mounting said assembly in said tank and for coupling said assembly to said conduits

- 16 -

whereby said assembly is operable to pump fuel through said conduits to said dispensers;

- c) said pump-motor assembly comprising a variable speed electric motor connected to an electrical power source to drive a fuel pump;
- d) vapor recovery means for conveying fuel vapor from the dispenser to a vapor recovery area, said vapor recovery means having an optimum efficiency with a fuel flow rate in a given range;
- e) sensors connected to the power source for determining the power drawn by said electric motor and providing power representative signals; and
- f) electric means responsive to said signals for adjusting the speed of said motor to maintain the fuel pressure in said flow conduits at a substantially constant pressure regardless of the fuel flow demand, said pressure producing a fuel flow rate in said given range.

6. A pumping system as set forth in claim 5, wherein said given range is substantially 8 to 10 gallons per minute.

7. A pumping system as set forth in claim 5, wherein said motor comprises a three-phase induction motor, and said motor drive means comprises a DC link.

- 17 -

8. The fuel pumping system of claim 5 further including a fuel pressure sensor in said fuel coupling means.

9. A pumping system for a fuel dispensing installation, the installation including at least one fuel storage tank, a plurality of fuel dispensers, and fuel flow conduits for conveying fuel from the storage tank to the dispensers, said pumping system comprising:

- a) a pump-motor assembly;
- b) means for mounting said assembly in said tank and for coupling said assembly to said conduits whereby said assembly is operable to pump fuel through said conduits to said dispensers;
- c) said pump-motor assembly comprising a variable speed electric motor connected to an electrical power source to drive a fuel pump;
- d) leak detector means for detecting a leak in said conduits during an initial period of energization of said pump-motor assembly;
- e) pressure boost means for driving said motor at a relatively high speed to produce a relatively high initial fuel pressure in said conduit during said initial period of energization;
- f) sensors connected to the power source for determining the power drawn by said electric motor and providing power representative signals; and

- 18 -

g) electric means responsive to said signals for adjusting the speed of said motor after said initial period of energization to maintain the fuel in said conduit at a substantially constant pressure which is lower than said high initial fuel pressure, regardless of the fuel flow demand.

10. A pumping system as set forth in claim 9, wherein said pressure boost means operates to produce an initial fuel pressure of approximately 35 psi.

11. A pumping system as set forth in claim 9, wherein said motor comprises a three-phase induction motor, and said motor drive means comprises a DC link.

12. The fuel pumping system of claim 9 further including a fuel pressure sensor in said fuel coupling means.

13. A pumping system for a fuel dispensing installation, the installation including at least one fuel storage tank, a plurality of fuel dispensers, and fuel flow conduits for conveying fuel from the storage tank to the dispensers, said pumping system comprising:

- a) a pump-motor assembly;
- b) means for mounting said assembly in said tank and for coupling said assembly to said conduits whereby said assembly is operable to pump fuel through said conduits to said dispensers;

- 19 -

- c) said pump-motor assembly comprising a variable speed electric motor connected to an electrical power source to drive a fuel pump;
- d) vapor recovery means for conveying fuel vapor from the dispenser to a vapor recovery area, said vapor recovery means having an optimum efficiency with a fuel flow rate in a given range;
- e) leak detector means for detecting a leak in said conduits during an initial period of energization of said pump-motor assembly;
- f) pressure boost means for driving said motor at a relatively high speed to produce a relatively high initial fuel pressure in said conduit during said initial period of energization;
- g) sensors connected to the power source for determining the power drawn by said electric motor and providing power representative signals; and
- h) electric means responsive to said signals for adjusting the speed of said motor after said initial period of energization to maintain the fuel in said conduit at a substantially constant pressure regardless of the fuel flow demand, said pressure producing a fuel flow rate in said given range.

- 20 -

14. A pumping system as set forth in claim 13, wherein said given range is substantially constant, and wherein said pressure boost means operates to produce an initial fuel pressure of approximately 35 psi.

15. The fuel pumping system of claim 13 further including a fuel pressure sensor in said fuel coupling means.

FIG. 1

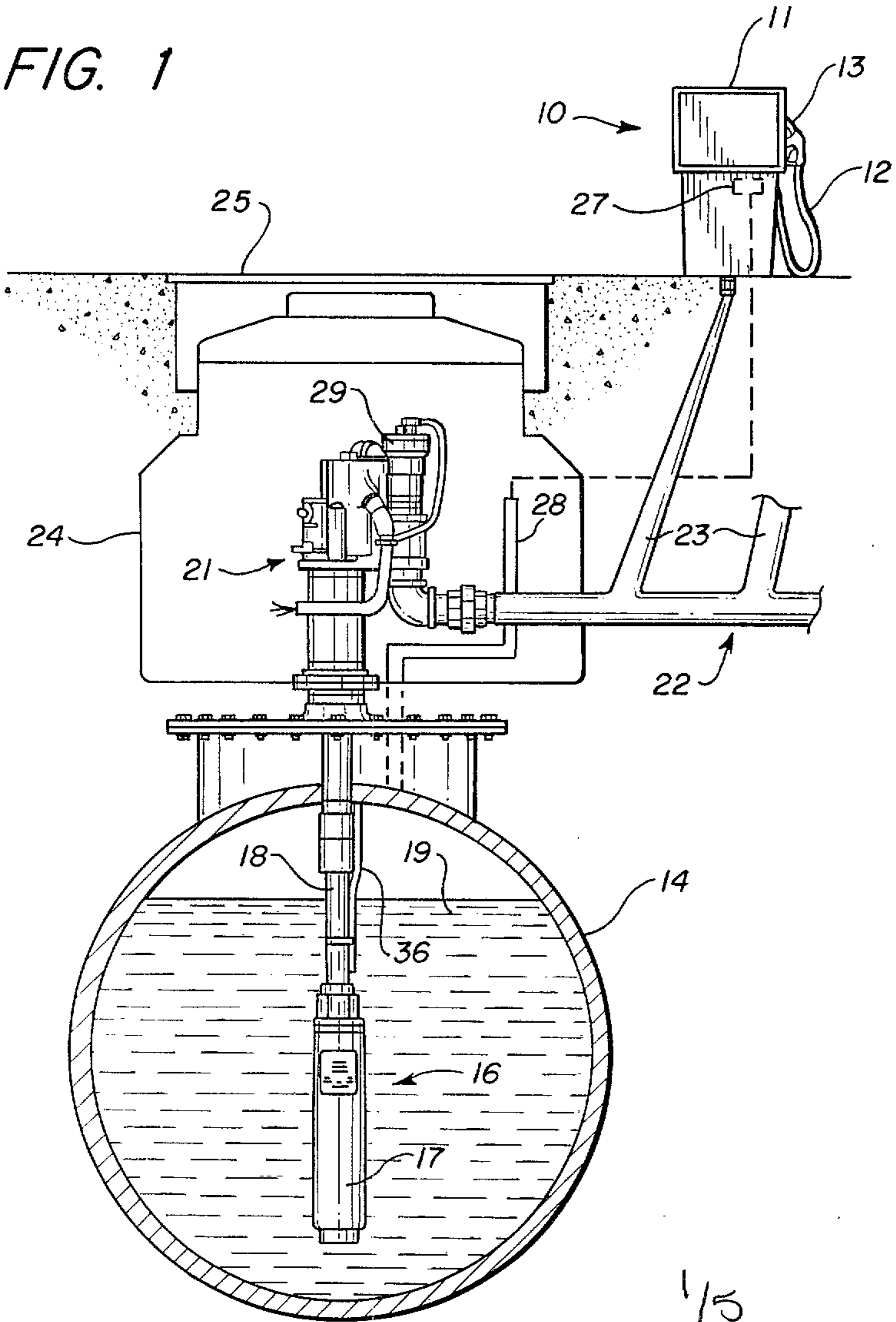

FIG. 2

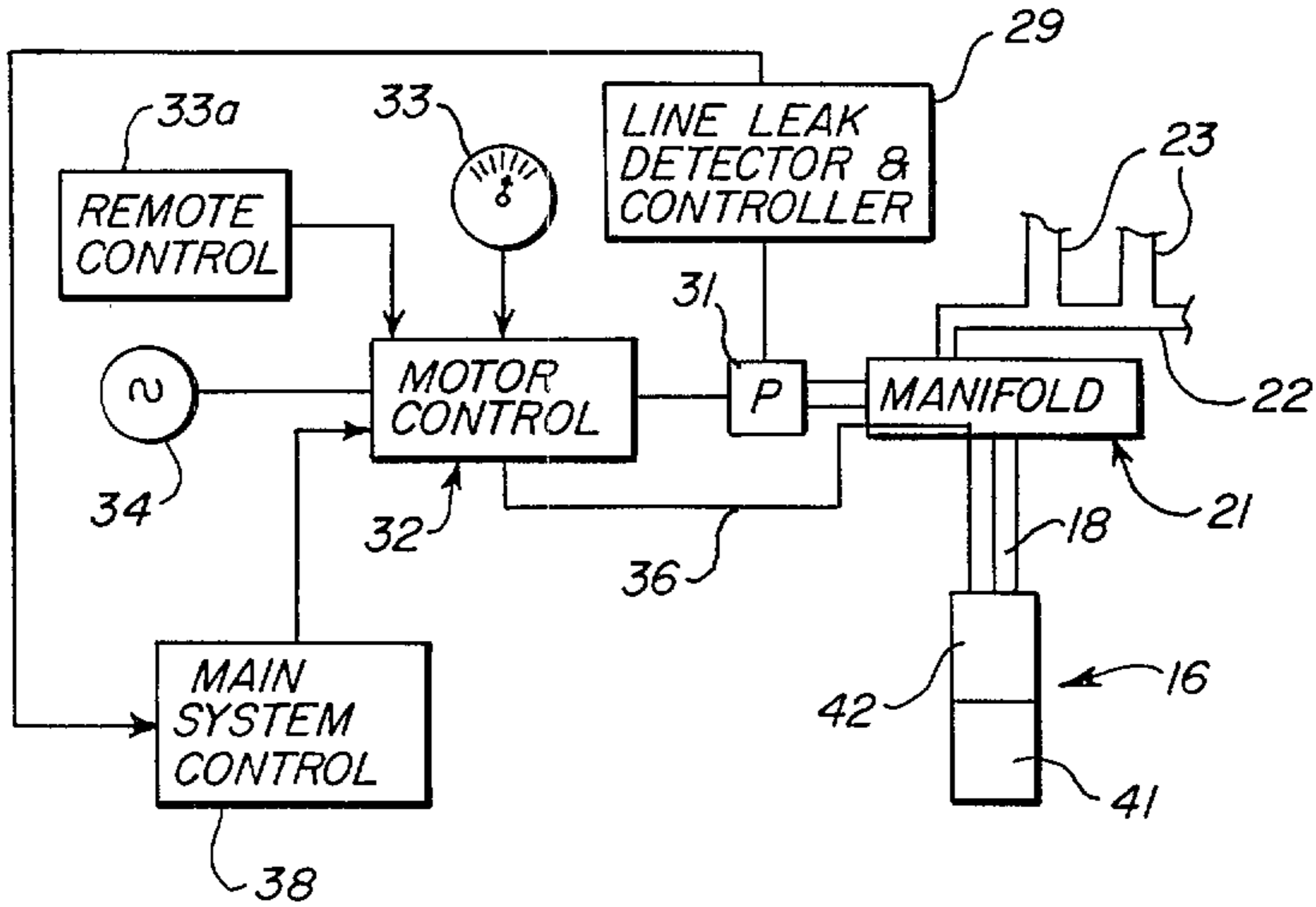

FIG. 7

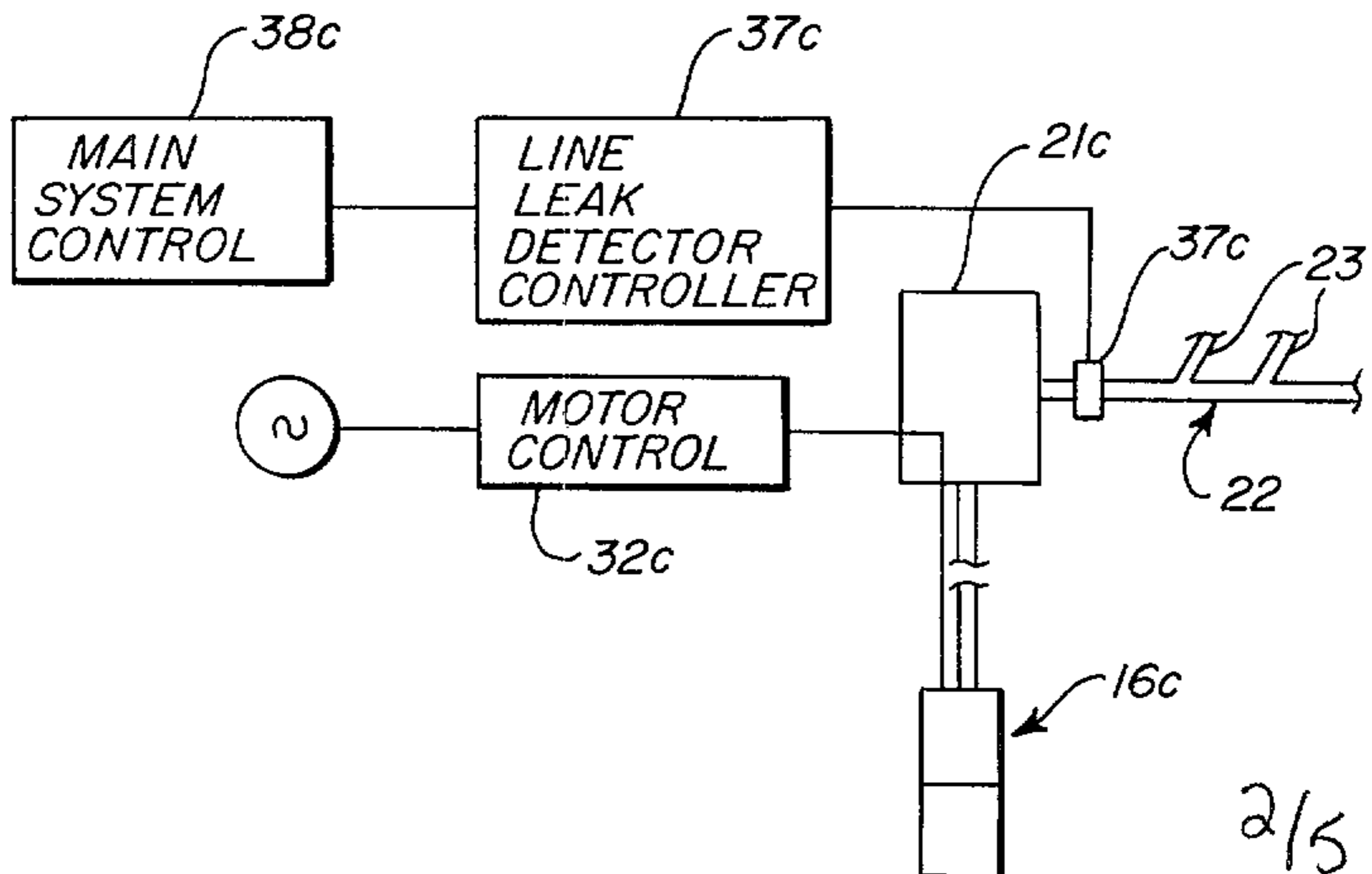

FIG. 3

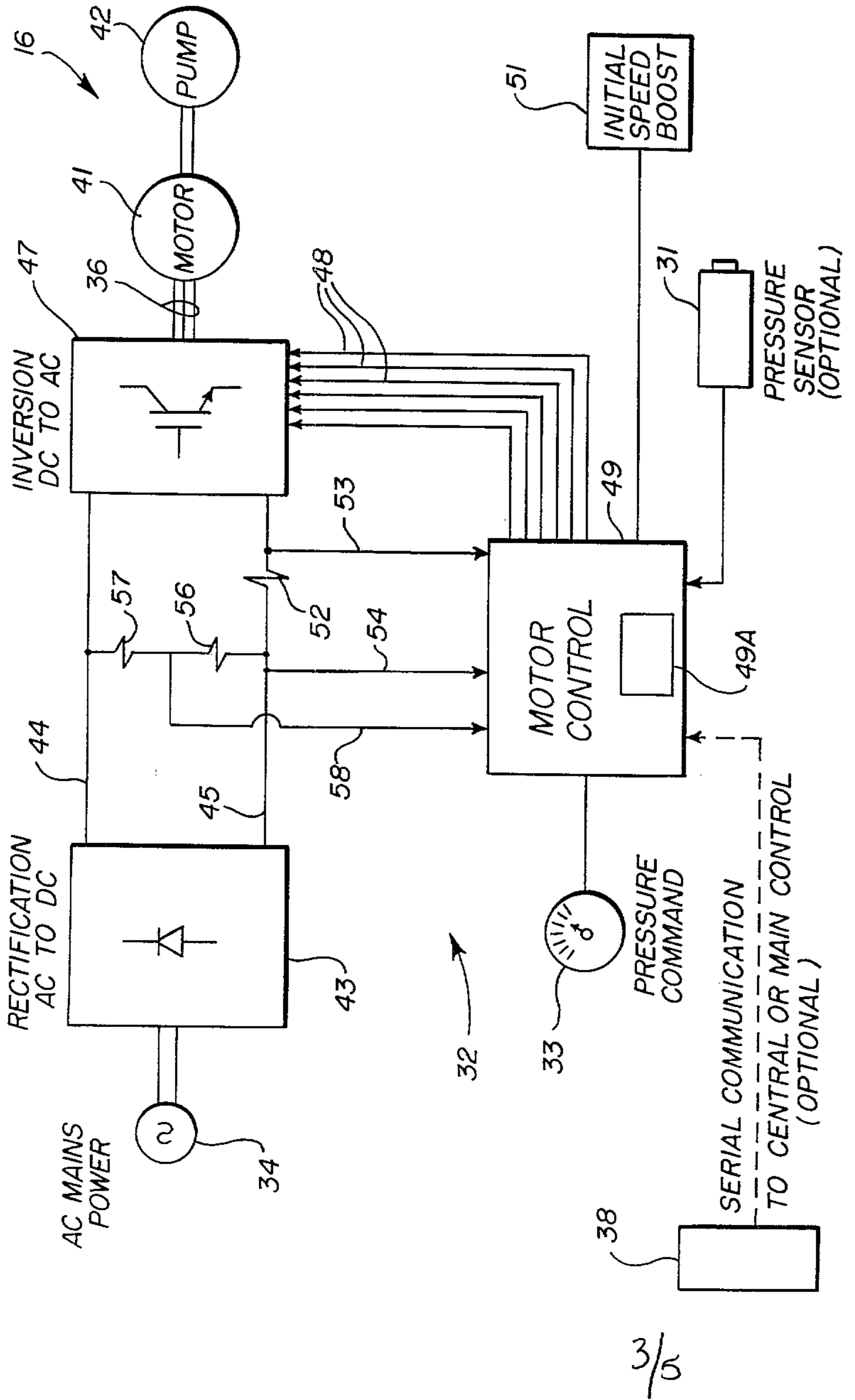

FIG. 4

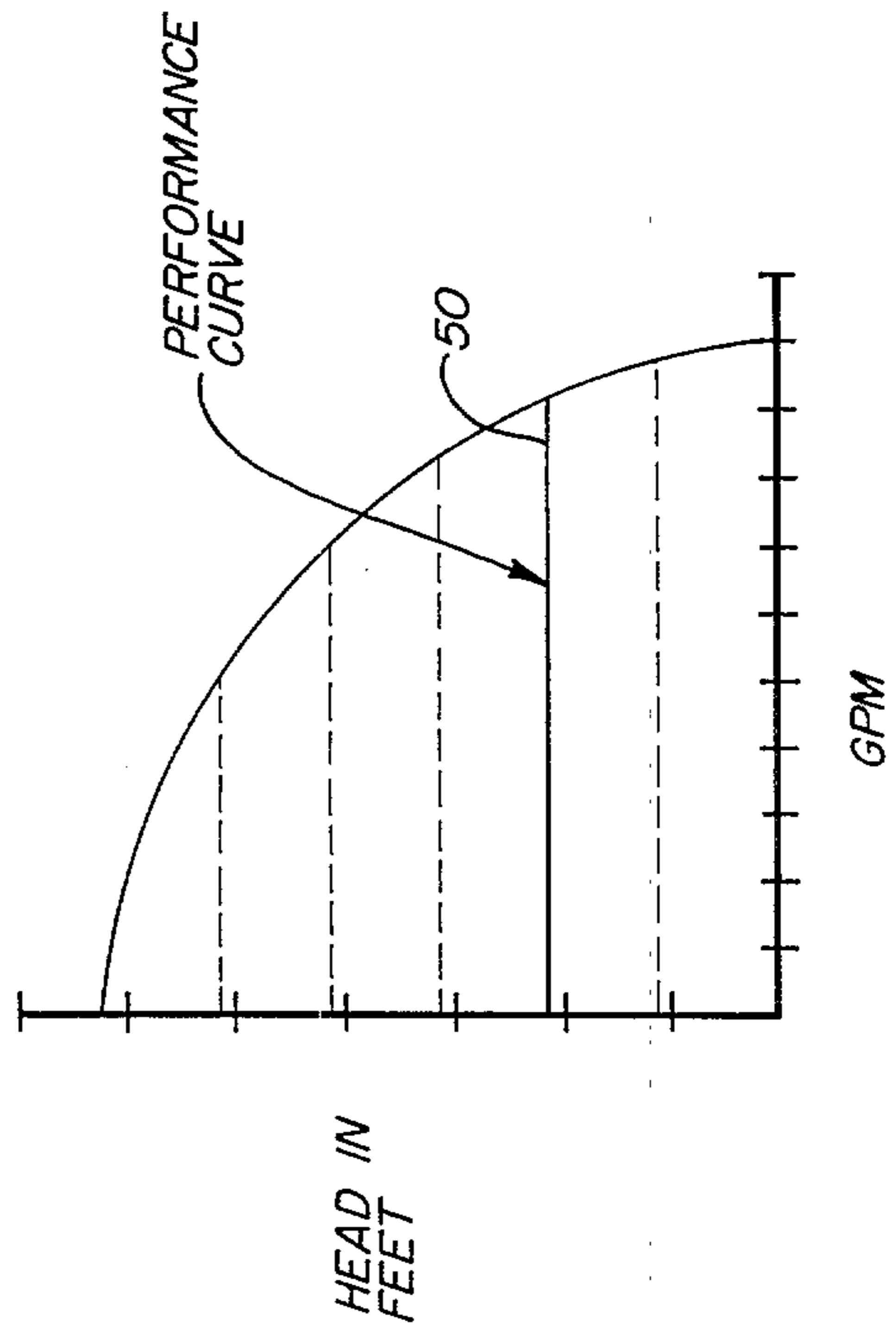

FIG. 5

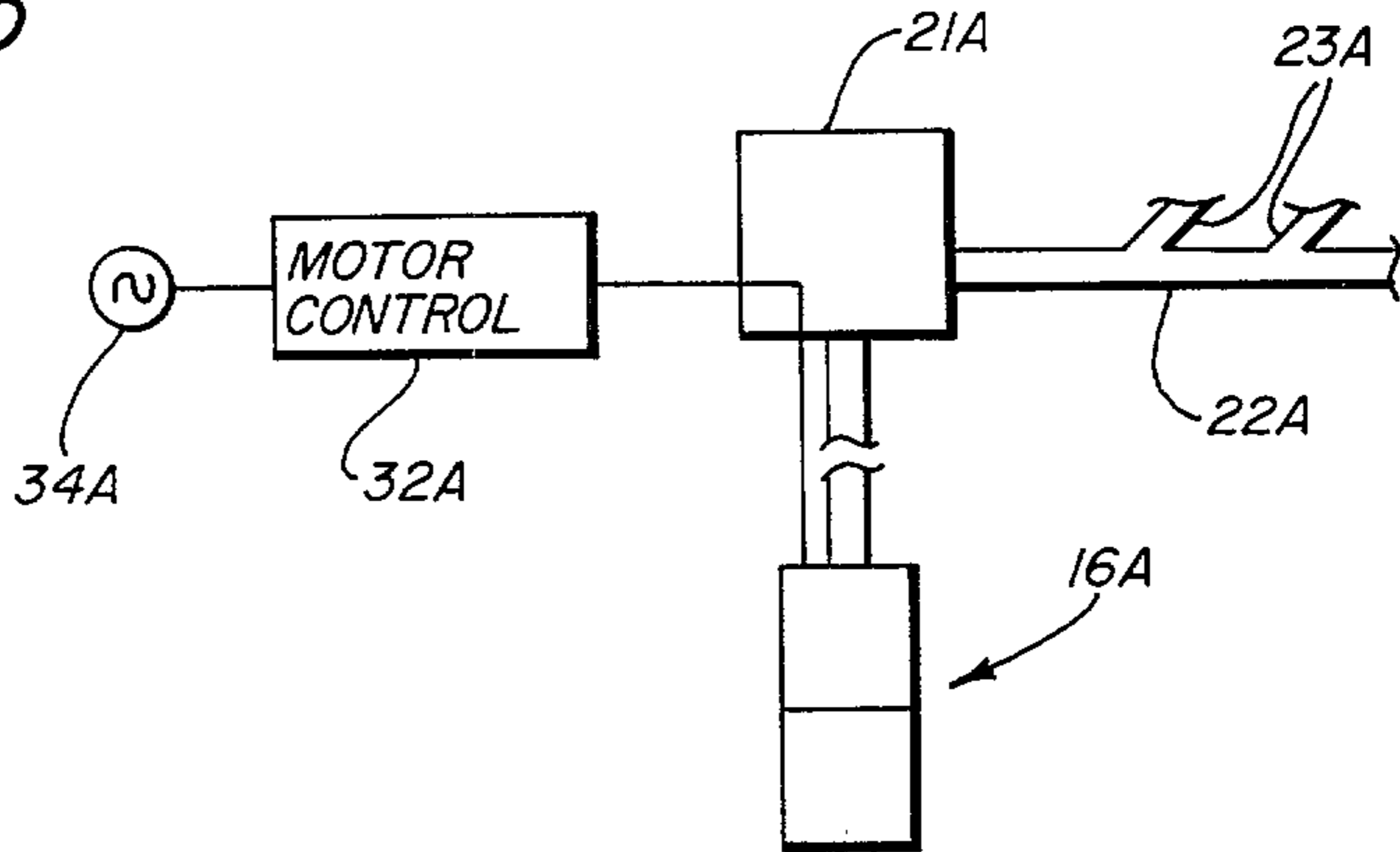

FIG. 6

