

A. M. MUNN.
 EXCAVATING MACHINE.
 APPLICATION FILED FEB. 24, 1910.

Patented July 18, 1911.

2 SHEETS—SHEET 1.

998,029.

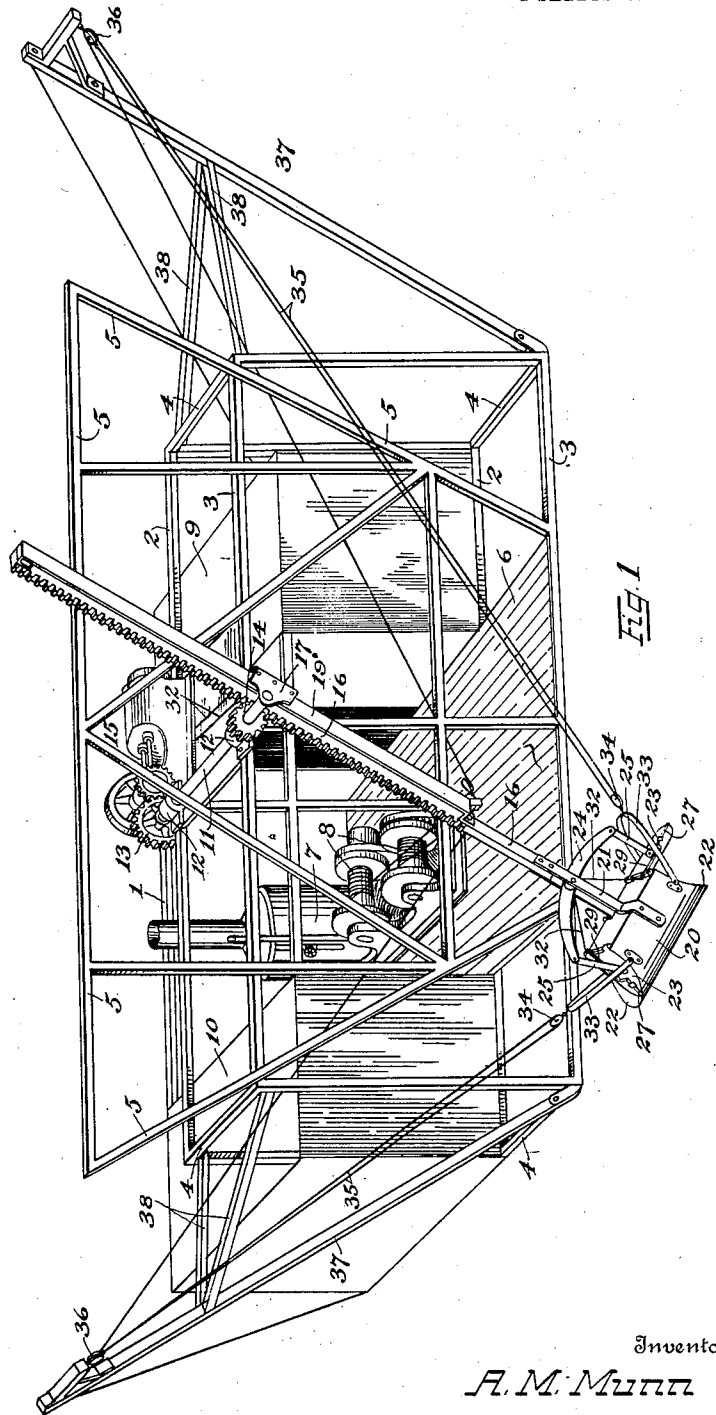

FIG. 1

Inventor

A. M. Munn

Witnesses

F. C. Valentine
A. C. Ollers

By

Obed B. Billman

Attorney

A. M. MUNN.
 EXCAVATING MACHINE.
 APPLICATION FILED FEB. 24, 1910.

998,029.

Patented July 18, 1911.

2 SHEETS—SHEET 2.

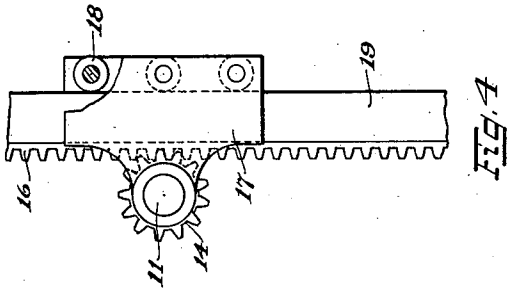

FIG. 4

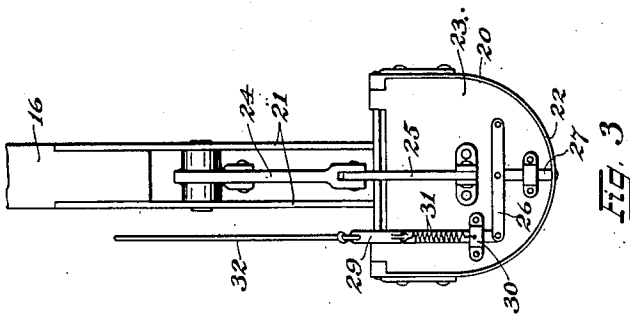

FIG. 3

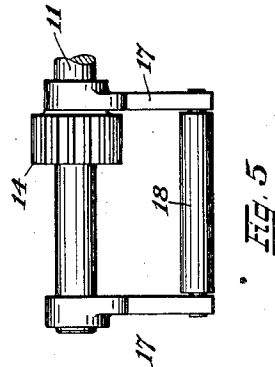

FIG. 5

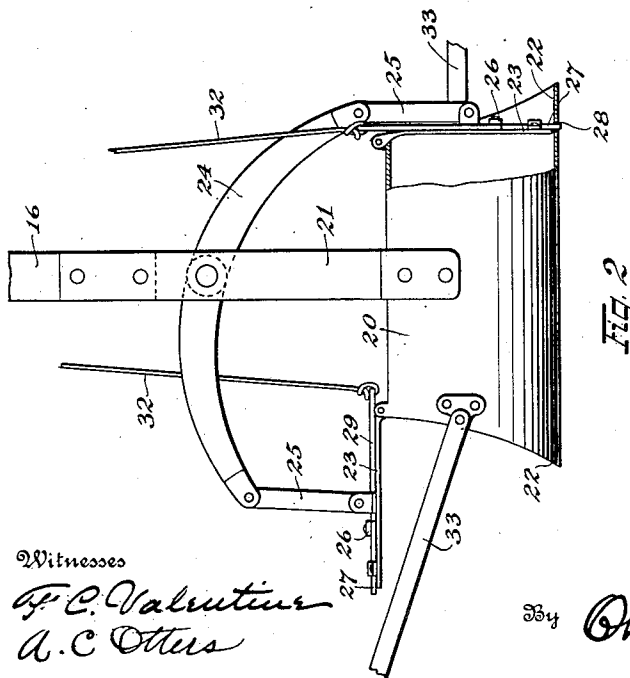

FIG. 2

Witnesses

F. C. Valentini
A. C. Otter

Inventor

A. M. Munn

By

Otho B. Billman

Attorney

UNITED STATES PATENT OFFICE.

ALEXANDER M. MUNN, OF NEBRASKA CITY, NEBRASKA.

EXCAVATING-MACHINE.

998,029.

Specification of Letters Patent.

Patented July 18, 1911.

Application filed February 24, 1910. Serial No. 545,861.

To all whom it may concern:

Be it known that I, ALEXANDER M. MUNN, citizen of the United States, residing at Nebraska City, in the county of Otoe and State of Nebraska, have invented certain new and useful Improvements in Excavating-Machines, of which the following is a specification.

My invention relates to improvements in excavating machines, the primary object of the invention being to provide a generally improved machine of this class of simple, cheap, and efficient construction better adapted to its intended purposes than any other machine of the same class with which I am acquainted.

A further object is to provide a generally improved trussed frame work which may be readily disconnected or disassembled for transportation, and which at the same time may be readily assembled or set up for use.

A still further object of the invention is to provide a generally improved bucket provided with oppositely disposed digger ends and means for alternately opening and closing said digger ends as the bucket is reciprocated by means of a bucket rack-arm adapted to have a to and fro or pendulum like movement whereby the bucket is brought into active operation during said to and fro movements and is adapted to alternately deposit its accumulated material at the ends of the path of reciprocation.

With the above mentioned and other ends in view, the invention consists in the novel construction, arrangement, and combination of parts, hereinafter described, illustrated in one of its embodiments in the accompanying drawings, and particularly pointed out in the appended claims.

Referring to the drawings forming a part of this specification, Figure 1, is a perspective view of an excavating machine constructed in accordance with this invention. Fig. 2, a side elevation of the improved excavating bucket, a portion of its side walls being broken away for purpose of clearer illustration of the parts. Fig. 3, an end view of the same. Fig. 4, a detail side elevation of a portion of the bucket rack-arm and the adjacent actuating shaft and pinion, and rack-arm guide member carried upon the end of said actuated shaft. Fig. 5, a detail

top plan view of the actuating shaft and pinion with its guide member, the rack-arm being removed.

Similar numerals of reference designate like parts throughout all the figures of the drawings.

The present embodiment of the invention is particularly designed for use on land in the excavation of ditches and the like, the improved frame work, together with the engines, boilers and other machinery being adapted to rest on the solid ground ahead of the work, the improved excavating bucket being adapted to be reciprocated transversely and to alternately deposit its material at the sides of the excavation.

The machine may be self-propelled by any suitable and convenient propelling device or it may be rested on rollers and ground planks in a well-known and understood manner.

The improved machine comprises a suitable frame work, in the present instance, made up of vertical trussed frames 1, 2, and 3, suitably connected as by connecting bars or beams 4, at the ends or corners to form the frame work when set up. The frames 1, 2, and 3, may be provided with suitable trussed work and the frame 3, is additionally strengthened and stiffened by means of a trussed frame 5. The intermediate base portion of the trussed frame may be provided with a floor 6, adapted to carry an ordinary excavator engine 7, provided with suitable winding drums 8. A coal-bin or box 9, may be provided at one side and a water tank or reservoir 10, at the other.

A driving or pinion shaft 11, is mounted in suitable bearings 12, on top of the frames 2, and 3, said driving shaft being provided at one end with a gear wheel 13, and at the other with a pinion 14. The driving or pinion shaft is adapted to be revolved in either direction by being suitably geared to a reversible engine 15.

The bucket rack-arm 16, is operatively connected to the pinion 14, by being slidably mounted and held in contact therewith by means of a guide member 17, carried upon the end of the driving shaft 11, and as a means for reducing friction, a plurality of anti-friction rollers 18, may be provided, said friction rollers being adapted

to operate against the side of the rack-arm opposite pinion 14. As a means for preventing a lateral displacement or swinging motion of the bucket rack-arm, a friction guide bar 19, may be provided at one side, said guide bar being adapted to abut against one side of the guide member 17.

The improved excavating bucket 20, is secured to the lower or free end of the rack-arm 16, by means of supporting straps or bars 21, and as a means for providing for the active digging operation of the bucket during both the to and fro movements of the rack-arm, said bucket is double ended and provided with oppositely disposed digger ends 22, and as a means for alternately opening and closing said ends during the reciprocation of said bucket, hinged doors or end closures 23, are provided, said doors being adapted to be simultaneously operated during their opening and closing movements by means of a walking beam 24, carried between the supporting bars 21, of the bucket, said walking beam being provided at its ends with connecting links or bars 25, pivotally connected to the outer sides of said floors or closures 23, and as a means for latching, each door or closure in its closed position, a pivotally mounted latch bar 26, is provided, said latch bar carrying a depending latching bolt 27, adapted to fall into an opening 28, in the digger end portion of the bucket. The latch bar 26, is connected to a second member 29, mounted in a guide bracket 30, on the door or closure 23, said member 29, being adapted to operate against the resistance of a spring 31, when the latch bolt 27, is withdrawn by means of the trip line 32. The trip lines 32, may extend along the bucket rack-arm and to a suitable part of the trussed frame work for convenient operation as shown, and it will be observed that the relative disposition of the operating parts and closures of the excavating bucket are such that when the lowermost door or end closure 23, is disengaged the opposite door or closure 23, will fall by gravity and the latching bolt 27, will automatically latch the door in its closed position.

As a means for reciprocating the improved excavating bucket in the digging operation, said bucket is provided at each end with a bail member 33, each bail member being provided with a pulley 34, over which passes a rope or cable 35, said cables 35, extending in opposite directions and passing over pulleys 36, carried at the upper ends of oppositely extending booms 37, and thence extending over suitable pulleys to the respective winding drums 8, of the excavator engine 7, and operating in a well known and understood manner.

The booms may be pivotally mounted at their base ends to the lower front corners of the trussed frame work as shown and

braced by means of brace members 38, extending from the corners of the frame work to hold the booms 37, in any desired position.

From the foregoing description, taken in connection with the accompanying drawings, the operation and advantages of my invention will be readily understood.

Having thus described an embodiment of my invention, what I claim and desire to secure by Letters Patent is,—

1. In an excavating machine, a double ended excavating bucket provided with end closures and a walking-beam whereby said end closures are adapted to be alternately opened and closed.

2. In an excavating machine, a double ended excavating bucket, end closures therefor, and means for alternately opening and closing said end closures.

3. In an excavating machine, a bucket rack-arm carrying a bucket provided with digger ends extending in the direction of the reciprocation of said rack-arm, and means for simultaneously opening and closing said digger ends whereby the material may be alternately received and discharged through said digger ends.

4. In an excavating machine, a double ended excavating bucket, end closures therefor, a walking beam connected to said end closures, and latching mechanism carried by said end closures.

5. In an excavating machine, a rack-arm carrying a bucket provided with oppositely extending digger ends, end closures therefor, means for alternately opening and closing said end closures, latching mechanism for said end closures, means for reciprocating said rack-arm and bucket, and means for operating said latching mechanism.

6. An excavating machine, comprising a trussed frame, a pinion-shaft, a rack-arm carrying a double ended bucket, means for alternately opening and closing the ends of said bucket whereby the material may be alternately received and discharged through said ends, means for revolving said pinion-shaft, and means for oscillating said rack-arm.

7. An excavating machine, comprising a frame, a pinion-shaft carried thereby, a rack-arm operatively connected to said pinion-shaft, a double ended bucket carried by said rack-arm, means for alternately opening and closing the ends of said bucket whereby the material may be alternately received and discharged through said ends, means for operating said pinion-shaft, and means for oscillating said rack-arm.

8. An excavating machine, comprising a frame, a pinion-shaft provided with a guide, a rack-arm slidably mounted in said guide and meshing with said pinion-shaft, a bucket carried by said rack-arm and provided with oppositely disposed excavating ends, doors

for closing said ends, means for alternately opening and closing said doors, means for revolving said pinion shaft, and means for oscillating said rack-arm.

5 9. In an excavating machine, a bucket arm, means for reciprocating said arm, and a bucket provided with digger ends extending in the direction of the reciprocation of said arm, and means for alternately opening and closing said digger ends whereby the material may be alternately received and discharged therethrough.

10 10. In an excavating machine, a reciprocatory bucket arm, a double ended bucket provided with diggers extending in the direction of the reciprocation of said bucket arm, means for alternately accumulating and discharging material through the ends of said bucket, and means for reciprocating said bucket arm.

15 11. In an excavating machine, a reciprocatory bucket arm carrying a double ended bucket provided with diggers extending in the direction of the reciprocation of said bucket arm, and means for alternately accumulating and discharging material through and from the ends of said bucket as the latter is reciprocated.

20 12. An excavating machine, comprising a frame, a shaft carried thereby and provided with a guide, a pinion, a rack arm slidably mounted in said guide and meshed with

said pinion, a double ended bucket carried by said rack arm and provided with excavating ends extending in the direction of the reciprocation of said rack arm, doors for closing said excavating ends, and means for reciprocating said bucket arm. 35

13. In an excavating machine, a shaft provided with a guide, a pinion, a rack arm mounted in said guide and meshing with said pinion, a bucket carried by said rack arm and provided with oppositely disposed digger ends, end closures therefor, latching mechanism for said end closures, means for reciprocating said rack arm and bucket, and means for operating said latching mechanism. 40 45

14. In an excavating machine, a rack-arm carrying a bucket provided with oppositely extending digger ends, end closures therefor, means for closing said end closures, latching mechanism for said end closures, means for reciprocating said rack-arm and bucket, means for longitudinally moving said rack-arm, and means for operating said latching mechanism. 50 55

In testimony whereof I have affixed my signature, in presence of two witnesses.

ALEXANDER M. MUNN.

Witnesses:

GEORGE M. THOMAS,
H. J. ANDREWS.