(12) PATENT ABRIDGMENT (11) Document No. AU-B-36813/89
(19) AUSTRALIAN PATENT OFFICE (10) Acceptance No. 611038

(54) Title
PNEUMATIC CASH TRANSFER SYSTEMS AND CANISTERS FOR USE THEREIN

International Patent Classification(s)
(51)⁴ **B65G 051/06 B65G 051/26 B65G 051/34**

(21) Application No. : **36813/89** (22) Application Date : **19.05.89**

(87) WIPO Number : **WO89/11430**

(30) Priority Data

(31) Number (32) Date (33) Country
8812036 20.05.88 GB UNITED KINGDOM

(43) Publication Date : **12.12.89**

(44) Publication Date of Accepted Application : **30.05.91**

(71) Applicant(s)
TRIPMATIC LIMITED

(72) Inventor(s)
ALEXANDER DAVID DICKSON PORTER; AVI ROSENTHAL

(74) Attorney or Agent
DAVIES & COLLISON, 1 Little Collins Street, MELBOURNE VIC 3000

(56) Prior Art Documents
AU 19049/48 59.8
AU 134030 6580/46 59.8

(57) Claim

1. A canister for carrying bank notes in an air tube conveyor system comprising a pair of interconnected end members, characterised by a side opening extending substantially the length of the canister between the end members to permit bank notes to be fed into the canister, and a bank note holder arranged to receive and retain bank notes fed into the canister through the side opening, the bank note holder comprising a pair of clamping plates which are mounted between the end members and are biased towards each other to a closed position for retaining bank notes inserted between the plates, characterised in that the clamping plates are shaped and mounted so that, in the closed position, they

(11) AU-B-36813/89
(10) 611038

-2-

define a substantially V- shaped trough in which bank notes are received and are retained between the lower longitudinal edge portions of the plates at the root of the V-shaped trough.

OPI DATE 12/12/89 APPLN. ID 36813 / 89

AOJP DATE 25/01/90 PCT NUMBER PCT/GB89/00552

PCT

61-1038

INTERNATIONAL APPLICATION PUBLISHED UNDER THE PATENT COOPERATION TREATY (PCT)

<p>(51) International Patent Classification ⁴ : B65G 51/06, 51/26, 51/34</p>	<p>A1</p>	<p>(11) International Publication Number: WO 89/11430 (43) International Publication Date: 30 November 1989 (30.11.89)</p>
<p>(21) International Application Number: PCT/GB89/00552 (22) International Filing Date: 19 May 1989 (19.05.89) (30) Priority data: 8812036.5 20 May 1988 (20.05.88) GB (71) Applicant (for all designated States except US): TRIPMATIC LIMITED [GB/GB]; 32 The Priory, Blackheath, London SE3 9UZ (GB). (72) Inventors; and (75) Inventors/Applicants (for US only): PORTER, Alexander David, Dickson [GB/GB]; 23 Glenshiel Road, Eltham, London SE9 1AQ (GB). ROSENTHAL, Avi [IL/GB]; 32 Broadway, Gillingham, Kent RE8 6DU (GB). (74) Agent: MATHISEN, MACARA & CO.; The Coach House, 6-8 Swakeleys Road, Ickenham, Uxbridge, Middlesex UB10 8BZ (GB).</p>		<p>(81) Designated States: AU, GB, JP, US. Published With international search report. Before the expiration of the time limit for amending the claims and to be republished in the event of the receipt of amendments.</p>

(54) Title: PNEUMATIC CASH TRANSFER SYSTEMS AND CANISTERS FOR USE THEREIN

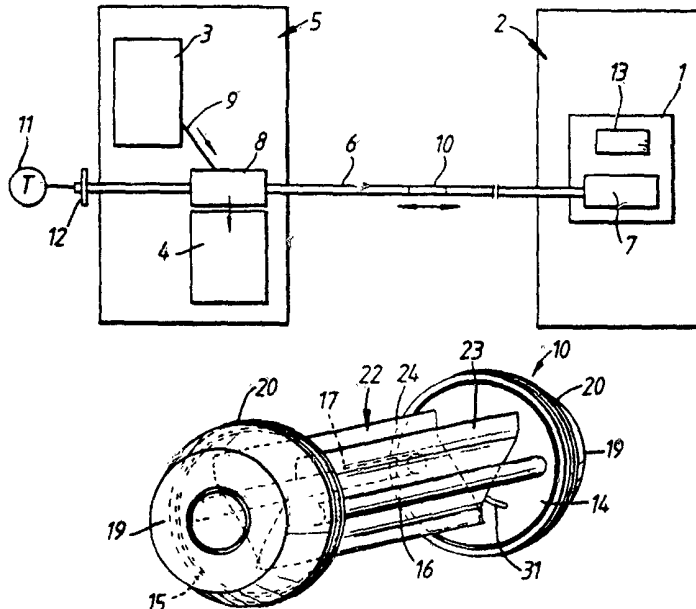

(57) Abstract

A pneumatic cash transfer system for use in banks and building societies to link a cashier station (1) to a remote teller assist unit (3) and a cash deposit box (4) in a separate secure area (5) comprises an air tube (6) extending between a tube terminal (7) at the cashier station and a tube terminal (8) in the secure area (5), and a cash carrying canister (10) movable pneumatically in the tube (6) between the two terminals (7, 8). The canister (10) is open at its side to permit insertion and removal of bank notes, and comprises a bank note holder (22) formed by a pair of spring-biassed clamping plates (23, 24) for holding bank notes firmly in the canister during travel in the tube (6). At the terminal (8) in the secure area (5) the holder (22) can be opened automatically to release notes to be deposited into the deposit box (4), and on reclosure of the holder it is ready to receive notes which are fed positively into the holder from the teller assist unit (3) for transmission to the cashier.

PNEUMATIC CASH TRANSFER SYSTEMS AND
CANISTERS FOR USE THEREIN

Security for both cash and staff has always been of major concern to banks, building societies, and other cash handling businesses (e.g. post offices) in which cash is dispensed and received by cashiers. Past attempts to reduce the level of risk inherent in such cash handling operations have included, inter alia, the introduction of security screens or grilles and teller assist units at counter positions, but even these have proved to be of only limited deterrent to the determined and ruthless criminal.

Now, with the increasing level of competition currently taking place within the financial services industry, the marketing of such services is becoming much more customer oriented. In particular, there is an accelerating trend towards "open plan" branches, personal counselling and dealing across a desk in place of the traditional counter service, and a move towards giving over as much space as possible to the customer. These trends increase the security problem even further.

Cashiers operating at a desk station generally have a teller assist unit, which is a unit containing a stock

of cash in a locked housing and providing the facility for the withdrawal of cash in required amounts in response to a request entered by the cashier. Such units may also be known as automatic teller safes or by some other name, but hereinafter they will be referred to as teller assist units, or TAU's for short. TAU's are similar in operation to the automatic cash dispensers which many banks and building societies provide for out-of-hours withdrawals, but as stand-alone units located at desk or other cashier points, they have disadvantages in that they remain vulnerable to particularly determined criminals, and their stocks of cash cannot be recirculated during business hours.

With the aim of overcoming these disadvantages it has been proposed to remove the TAU's from the cashier area to a remote and separate secure area, which may be time-locked, and to link each cashier station to its TAU by means of a pneumatic cash transfer system comprising an air tube in which a canister is moved back and forth in response to air pressure differentials created between the opposite ends of the tube to carry cash from the TAU to the cashier station and, if desired, from the cashier station to a deposit box also located in the secure area.

Air tube conveyor systems have been known for many years as a means of transporting a wide range of items (documents, valuables, samples, spare parts etc.) between different locations within a building, or even between adjoining buildings, and with suitable electronic controls it is considered that such a system is ideal for the above purpose. Air tube conveyor systems are capable of operating over any distance and in virtually any building, whether it is new or existing, and routes can be concealed above ceilings or below floors depending on the constructional constraints of the building concerned.

The above proposal using a pneumatic cash transfer system should serve to produce a much safer environment in banks, building societies, etc., where cashier/customer transactions take place. The system is such that no cash need be held at the cashier station (with the possible exception of a small float of loose coins), yet precise amounts of cash can be called up quickly as required from a secure area, and deposits can be sent back. Thus, at any time the only cash at risk will be the coin float and that which is being handled in the course of the current transaction. Furthermore, depending on the user's normal operating procedures, a full stock of cash will be available for immediate

PCT/GB 89 / 00552

31 July 1990
31-07-1990

4

recycling at all times, and if recharging of any TAU becomes necessary this can be carried out in total security.

The present invention relates to such a pneumatic cash handling system for linking a cashier station to a remote TAU in a secure area, and is particularly concerned with a canister for carrying bank notes in such a system.

According to a first aspect of the invention, there is provided a canister for carrying bank notes in an air tube conveyor system comprising a pair of interconnected end members, a side opening extending substantially the length of the canister between the end members to permit bank notes to be fed into the canister, and a bank note holder arranged to receive and retain bank notes fed into the canister through the side opening, the bank note holder comprising a pair of clamping plates which are mounted between the end members and are biased towards each other to a closed position for retaining bank notes inserted between the plates, characterised in that the clamping plates are shaped and mounted so that, in the closed position, they define a substantially V-shaped trough in which bank



SUBSTITUTE SHEET

notes are received and are retained between the lower longitudinal edge portions of the plates at the root of the V-shaped trough.

Generally such a canister will be designed for use in a system in which the bank notes are placed positively into the bank note holder, the clamping plates allowing the notes to be pushed easily between them while in the closed position so that the notes are immediately gripped and retained by the holder.

Preferably each of the end members is freely rotatably mounted in an end cap having a peripheral portion arranged to engage the air tube wall during travel of the canister through the tube, and at least one of the end members is eccentrically weighted so that the interconnected end members will together rotate relative to the end caps to a predetermined position when the canister is at rest. In this way it can be ensured that the bank note holder will always be oriented correctly when the canister comes to rest, irrespective of any frictional resistance between the end caps and the air tube.

According to a second aspect of the invention, there is provided a pneumatic cash handling system comprising an

air tube, a canister as defined above freely slidable along the length of the tube between a cashier station tube terminal and a TAU tube terminal in a secure area remote from the cashier station, and means for controlling the air pressure in the tube to drive the canister back and forth between the two tube terminals, the TAU tube terminal (and preferably also the cashier station tube terminal) comprising a portion of the air tube having a longitudinally extending opening in its wall for providing access to the bank note holder of the canister when the canister is received in the tube terminal, means for stopping the canister in the tube terminal in a predetermined position relative to the opening, a rotatable sleeve closely surrounding the tube portion of the terminal and having a longitudinally extending opening substantially corresponding to the tube opening, and means for rotating the sleeve to move it between an open position in which its opening registers with the tube opening and a closed position in which the tube opening is shut by the sleeve.

The system will be provided with a suitable automatic control system linked to the TAU and operated from the cashier station, e.g. via a keyboard. In operation, if a customer wishes to make a cash withdrawal, the cashier keys the nature of the transaction and the amount

required (preferably after first keying a security access code) and the system then operates automatically to ensure that the canister is correctly located at the TAU tube terminal (which preferably will be arranged to be the canister's home station), to open the terminal, to receive the required number and denomination of bank notes from the TAU into the holder, to close the terminal, and to send the canister to the cashier station tube terminal. Preferably the system also operates automatically to open the cashier station tube terminal when the canister arrives, so that the cashier simply has to lift the notes from the holder. However, the opening of the cashier station tube terminal may be manual if preferred.

Generally the system will be required also to handle cash deposits as well as withdrawals, and for this purpose the canister preferably has a side opening which permits bank notes to be discharged from the canister at a position substantially diametrically opposite that at which the notes are fed in, and the bank note holder is movable to a release position to allow bank notes to fall from the holder through the discharge side opening. In addition, the tube portion of the TAU tube terminal has a second longitudinally extending opening disposed at the bottom of the tube portion diametrically

opposite the first opening thereof, and the sleeve also has a second longitudinally extending opening diametrically opposite the first sleeve opening and substantially corresponding to the second opening of the tube portion so that each sleeve opening registers with the corresponding opening of the tube portion when the sleeve is moved to the open position and both openings of the tube portion are shut when the sleeve is moved to the closed position, the TAU tube terminal also comprising means for causing the bank note holder of the canister to release bank notes for discharge through the registering second openings of the tube portion and the sleeve when the sleeve is in the open position and the notes are to be deposited in the secure area.

To assist further understanding of the invention, preferred examples of the canister and pneumatic cash handling system in accordance with the invention will now be described with reference to the accompanying diagrammatic drawings, in which:-

Figure 1 illustrates the general layout of one example of a system in accordance with the invention;

Figure 2 is a perspective view of one example of a canister in accordance with the invention for use in the

system of Figure 1;

Figure 3 is an axial section through one end of the canister;

Figure 4 is a cross-section through the canister in a plane perpendicular to its longitudinal axis and approximately mid-way between its ends;

Figure 5 is a cross-section through one example of a TAU tube terminal for use in the system of Figure 1, taken on the line V - V in Figure 6; and

Figure 6 is a side elevation of the tube terminal of Figure 5.

The pneumatic cash transfer system illustrated in Figure 1 links a single cashier station 1, for example a desk station, in an open transaction area 2 of a bank or building society to a teller-assist unit (TAU) 3 and a cash deposit box 4 located in a secure, time-locked area 5 remote and separate from the transaction area 2. The system comprises an air tube 6 extending between a tube terminal 7 at the cashier station 1 and a tube terminal 8 in the secure area 5, the terminal 8 being located above the cash deposit box 4 and below a bank note feed

device 9 from the TAU 3. Slidable within the air tube 6 is a canister 10 for carrying bank notes between the two tube terminals 7 and 8, and connected to the air tube at the TAU tube terminal 8 is a turbine blower 11 capable of selectively applying by means of a diverter 12 either suction or pressurised air to the air tube in order to move the canister 10 from the cashier station tube terminal 7 to the TAU tube terminal 8 or vice versa respectively. A speed of about ten metres/second should be possible. The diverter 12 is also capable of shutting off the blower 11 from the air tube 6 when not required. The system is controlled by the cashier at the cashier station 1 via a keyboard 13.

The canister 10 illustrated in Figures 2 to 4 comprises a pair of axially spaced circular end plates 14,15 which are rigidly interconnected by a pair of connecting rods 16,17 extending parallel to a common axis of the end plates and disposed symmetrically on opposite sides thereof inwardly of the rims of the end plates. As shown in Figure 3 in relation to the end plate 15, each end plate 14,15 is rigidly connected to a shaft 18 extending axially from its outer face, and a cup-shaped end cap 19 is rotatably mounted on this shaft 18 by means of a bearing (not shown). The rim of the end cap 19 closely surrounds the end plate and is fitted on its

outer periphery with a circumferential seal 20 made of a suitable low friction material to facilitate the movement of the canister through the air tube. Mounted on the shaft 18 within the space bounded by the end cap 19 at either or both ends of the canister is an eccentric weight 21 so that the centre of gravity of the portion of the canister rotatably mounted between the end caps is displaced radially from its longitudinal axis. Thus, irrespective of the angular position of the end caps 19, gravitational action will always cause the central portion of the canister to adopt a predetermined position when the canister is at rest as a result of the central portion being free to rotate relative to the end caps.

The canister 10 is completely open at the side so that it effectively has a single side opening extending the length of the canister between the end plates 14,15 and circumferentially all the way round the canister. Furthermore, the canister comprises a bank note holder 22 mounted between the end plates 14,15 and comprising a pair of clamping plates 23,24 which are spring-biased relatively towards each other to a closed, clamping position. The clamping plates 23,24 are shaped and mounted so that, in the clamping position as shown in Figures 2 and 4, they define a substantially V-shaped

trough with convexly curved lower edge portions 23a,24a biased towards engagement with each other at a position offset from the axis of the canister in the direction of its eccentric centre of gravity, and with their upper edge portions 23b,24b spaced relatively widely apart to allow bank notes to be fed positively into the holder. The spring bias acting on the clamping plates is such that a number of bank notes inserted into the holder can be pushed relatively easily between the closed lower edge portions 23a,24a, but will remain held therebetween when released by the insertion mechanism.

In order to facilitate the insertion of only one or two notes at a time, however, it is preferable that the lower edge portions 23a,24a of the clamping plates do not actually meet but are slightly spaced from each other in the closed position as shown in Figure 4. In this case each clamping plate 23,24 is provided with a plurality of flexible fingers 25,26 respectively, for example of a plastics material, which extend from its lower longitudinal edge portion at intervals along the length thereof and interdigitate with the fingers of the other clamping plate as shown, the fingers 25,26 being deflectable to allow the bank notes to be inserted and held between them.

If desired the insertion of bank notes between the clamping plates 23 and 24 may be facilitated by coating the facing surfaces of the plates with a low friction material such as polytetrafluoroethylene, and the gripping action of the plates may be improved by providing the facing surfaces of at least the lower portions of the plates with a number of ribs (not shown) lying in planes perpendicular to the axis of the canister and offset from each other.

One of the clamping plates 24 is fixed in position relative to the end plates 14,15, while the other clamping plate 23 is pivotally mounted on the end plates by pivot pins 27 so that the plate 23 is able to pivot about an axis 28 which is parallel to the axis of the canister and is positioned towards the upper edge portion 23b of the clamping plate. The pivot pins 27 are carried by the clamping plate 23 and are received in bearings fitted in the end plates, the pins 27 projecting into the space bounded by the end caps 19 where they co-operate with springs 29 so that the clamping plate 23 is biased to pivot in a direction to move its lower end portion towards the lower edge portion of the fixed plate 24. As will be appreciated, pushing the upper edge portion 23b of the pivoted clamping plate 23 towards the fixed clamping plate 24

while preventing rotation of the end plates 14,15 will cause the lower edge portion 23a of the pivoted clamping plate to move away from the fixed clamping plate 24 against the action of the biasing springs 29 so that the lower end of the holder 22 is thereby opened to release bank notes therefrom. Near its lower edge portion 23a, the pivoted clamping plate 23 has a further pair of pins 30 projecting into arcuate guide slots 31 provided in the end plates 14,15 for guiding the movement of the lower edge portion of the clamping plate 23 during opening and closing of the holder 22. The ends of the slots 31 also serve to limit the open and closed positions of the holder 22.

Turning now to Figures 5 and 6, a TAU tube terminal 8 is shown comprising a support frame formed by a pair of axially spaced rectangular end plates 32,33 interconnected at the corners by longitudinally extending bars 34. The air tube 6 of the system extends horizontally through, and is supported by, each end plate 32,33 and the portion 35 of the air tube between the end plates is provided with upper and lower longitudinally extending openings 36,37 respectively which are positioned diametrically opposite each other. The lower opening 37 is symmetrical about its longitudinal axis, whereas the upper opening 36 has each

end offset in opposite circumferential directions to provide a wider portion 36a on one side at one end, and a corresponding wider portion 36b on the other side and at the other end.

A cylindrical sleeve 38 closely surrounds the tube portion 35 between the end plates 32,33 and is rotatable about the tube portion by means of a drive belt 39 driven by an electric motor 40 mounted on one of the frame bars 34. The sleeve 38 is provided with a pair of diametrically opposite, longitudinally extending openings 41,42 corresponding in shape and size to the openings 36,37 of the tube portion 35. Thus, the sleeve 38 can be rotated to an open position in which its openings 41,42 register with the openings 36,37 of the tube portion 35, and can also be rotated to a closed position in which the sleeve openings and the tube openings are totally out of registry and the tube openings are thereby closed by the walls of the sleeve between its openings.

A pair of holder opening levers 43,44 are pivotally mounted on the upper frame bars 34 on opposite sides of the sleeved tube portion 35 so that, when the sleeve 38 is in the open position, the levers 43,44 are capable of moving horizontally into the interior of the tube

portion 35 through the widened portions 36a,36b respectively of its upper opening. The levers 43,44 are pivoted into and out of the tube 35 by means of solenoid operated actuators 45,46 also mounted on the upper frame bars 34. If preferred, the actuators 45,46 may be pneumatically or hydraulically operated.

Advantageously, the turbine blower 11 for driving the canister 10 back and forth between the cashier station tube terminal 7 and the TAU tube terminal 8 is connected through the diverter 12 to the air tube 6 at a position adjacent the near end of the TAU tube terminal (relative to the cashier tube terminal) via a non-return valve 47 which permits air to be sucked from the air tube but not to be blown into the tube, and is also connected to the air tube at a position adjacent the far end of the TAU tube terminal via a non-return valve 48 which permits air to be blown into the air tube but not to be sucked therefrom. As illustrated in Figure 6, in this example the air tube 6 is connected beyond the TAU tube terminal 8 through the valve 48 to a duct 49 which leads back through the end plates 32,33 of the terminal to the turbine blower and diverter (not shown), the valve 47 connecting the duct 49 to the air tube 6 in front of the terminal 8. With this arrangement, a canister is moved from the TAU tube terminal 8 to the cashier terminal 7

by causing the turbine blower to blow air through the duct 49 to the end of the air tube 6 via the valve 48, thus propelling the canister towards the cashier station. On the other hand, when the canister is to be returned to the TAU tube terminal, the turbine blower is caused to suck air from the air tube 6 via the valve 47, thus drawing the canister towards the TAU tube terminal 8. This has the advantage that as the canister passes the valve 47 in front of the terminal 8, further evacuation of the tube portion 35 within the terminal 8 is prevented and the canister is braked by a cushion of air within the tube portion of the tube terminal before coming to rest in the tube terminal 8 against an end stop (not shown).

When the canister comes to rest, the motor 40 is operated, possibly in response to a signal from the end stop, to rotate the sleeve 38 to the open position. The eccentrically weighted, freely rotatable central portion of the canister naturally comes to rest with the spaced upper edges 23b,24b of the bank note holder 22 facing upwards to the registering openings 36,41 of the sleeved tube portion. If the holder 22 carries bank notes for deposit, the actuators 45,46 operate automatically (in response to a programme preselected by the cashier) to cause the holder opening levers 43,44 to

pivot so that an arm of each lever moves into the tube portion 35 through the widened portions 36a,36b of the upper opening. The end of each arm moving into the tube portion 35 carries a roller 50,51 for engaging the outer face of the corresponding clamping plate 23,24 near its upper edge. The lever 44 engages the fixed clamping plate 24 solely to prevent rotation of the canister about its axis upon engagement of the other clamping plate 23 by the lever 43, which is arranged to push the upper edge portion of the clamping plate 23 so that the plate 23 pivots about its pivot axis 28 to move the lower edge portion 23a of the clamping plate away from the fixed plate to the open position 23c shown in Figure 4. This allows the bank notes previously held by the holder 22 to fall from the holder through the registering bottom openings 37,42 of the tube and sleeve into the deposit box 4. The holder opening levers 43 and 44 are then retracted out of the sleeved tube portion 35 to allow the clamping plate 23 to return to the closed position of the holder ready to receive the next cash withdrawal from the TAU.

When a withdrawal is called for by the cashier, the TAU feed device 9 inserts the bank notes through the registering upper openings 36,41 and into the bank note holder 22, the notes being pushed between the lower end

portions 23a,24a and the fingers 25,26 of the clamping plates 23,24. The feed device then releases the thus gripped bank notes, and is retracted from the sleeved tube portion 35. The sleeve 38 is then rotated to the closed position, and the turbine blower operated to propel the canister to the cashier station for removal of the bank notes by the cashier.

As mentioned earlier, the system may be controlled to operate completely automatically in response to instructions entered on the keyboard 13 by the cashier. Furthermore, the control system (the details of which form no part of the present invention) can be designed to record automatically all cash transactions, both withdrawals and deposits, and to provide for full integration of the data recording system and access codes, etc., with a master computer system.

It will be appreciated that the system in accordance with the invention is also particularly suitable for use with an automatic cash dispensing unit instead of a manned cashier station as described, the advantage being that the unit itself will not need to be stocked with a reserve of cash since this will be contained at a remote position in the secure area within the building. Thus, the automatic dispensing unit itself does not need to be

made secure and will therefore need less space.

It will also be appreciated that the system and canister in accordance with the invention can be used to handle other documents connected with financial transactions besides bank notes, such as cheques, travellers cheques, debit and credit vouchers, etc. References to bank notes appearing hereinbefore and in the following claims are accordingly to be construed as meaning bank notes and other financial transaction documents.

- 21 -

CLAIMS

1. A canister for carrying bank notes in an air tube conveyor system comprising a pair of interconnected end members, characterised by a side opening extending substantially the length of the canister between the end members to permit bank notes to be fed into the canister, and a bank note holder arranged to receive and retain bank notes fed into the canister through the side opening, the bank note holder comprising a pair of clamping plates which are mounted between the end members and are biased towards each other to a closed position for retaining bank notes inserted between the plates, characterised in that the clamping plates are shaped and mounted so that, in the closed position, they define a substantially V-shaped trough in which bank notes are received and are retained between the lower longitudinal edge portions of the plates at the root of the V-shaped trough.

2. A canister according to claim 1 having a side opening which permits bank notes to be discharged from the canister at a position substantially diametrically opposite that at which the notes are fed in, the bank note holder being movable to a release position to allow bank notes to fall therefrom through the discharge side opening.



SUBSTITUTE SHEET

- 22 -

3. A canister according to claim 1 or claim 2, in which the side of the canister is completely open between the end members.

4. A canister according to any one of claims 1 to 3, in which the lower longitudinal edges of the clamping plates are slightly spaced from each other in the closed position, and each clamping plate is provided with a plurality of flexible fingers which extend from its lower longitudinal edge and interdigitate with the fingers of the other clamping plate, the fingers being deflectable to allow bank notes to be inserted between them.

5. A canister according to any one of claims 1 to 4, in which at least one of the clamping plates is pivotally mounted on the end members so that the plate can pivot about an axis substantially parallel to the longitudinal axis of the canister, and is biased by spring means to pivot in a direction to move the lower longitudinal edge of the plate towards the corresponding edge of the other plate.

6. A canister according to claim 5, in which only one of the clamping plates is pivotally mounted, the other being fixed in position relative to the end members.



12 June 1990
12 06 90

- 23 -

7. A canister according to claim 5 or claim 6, in which the or each pivotally mounted clamping plate is guided during pivotal movement of the plate by means of pins which are carried by the plate and project into guide slots provided in the end members.

8. A canister according to any one of the preceding claims, in which each of the end members is freely rotatably mounted in an end cap having a peripheral portion arranged to engage the air tube wall during travel of the canister through the tube, and at least one of the end members is eccentrically weighted so that the interconnected end members will together rotate relative to the end caps to a predetermined position when the canister is at rest.

9. A canister according to claim 8, in which the peripheral portion of each end cap is fitted with a circumferential seal made of a suitable low friction material to facilitate the movement of the canister through the air tube.

10. A pneumatic cash handling system comprising an air tube, a canister according to any one of the preceding claims freely slidable along the length of the tube between a cashier station tube terminal and a teller

OBJECT: TUTE S...
SECRETUnited Kingdom Patent Office
PCT Int. Bureau

- 24 -

assist unit (TAU) tube terminal located in a secure area remote from the cashier station, and means for controlling the air pressure in the tube to drive the canister back and forth between the two tube terminals, at least the TAU tube terminal comprising a portion of the air tube having a longitudinally extending opening in its wall for providing access to the bank note holder of the canister when the canister is received in the tube terminal, means for stopping the canister in the tube terminal in a predetermined position relative to the opening, a rotatable sleeve closely surrounding the tube portion of the terminal and having a longitudinally extending opening substantially corresponding to the tube opening, and means for rotating the sleeve to move it between an open position in which its opening registers with the tube opening and a closed position in which the tube opening is shut by the sleeve.

11. A system according to claim 10, in which the tube portion of the TAU tube terminal has a second longitudinally extending opening disposed at the bottom of the tube portion diametrically opposite the first opening thereof, and the sleeve also has a second longitudinally extending opening diametrically opposite the first sleeve opening and substantially corresponding to the second opening of the tube portion so that each



- 25 -

sleeve opening registers with the corresponding opening of the tube portion when the sleeve is moved to the open position and both openings of the tube portion are shut when the sleeve is moved to the closed position, the TAU tube terminal also comprising means for causing the bank note holder of the canister to release bank notes for discharge through the registering second openings of the tube portion and the sleeve when the sleeve is in the open position and the notes are to be deposited in the secure area.

12. A system according to claim 11, in which the first openings of the tube portion and the sleeve of the TAU tube terminal each has each end offset in opposite circumferential directions to provide a wider portion on one side at one end, and a corresponding wider portion on the other side and at the other end.

13. A system according to claim 12, in which the means for causing the bank note holder to release bank notes comprises a pair of holder opening members which are mounted in the TAU tube terminal on opposite sides of the sleeved tube portion and are movable into the tube portion through the wider portions of the registering first openings of the sleeve and tube portion when the sleeve is in the open position.



PCT/GB 89/00552
12 June 1990
12 06 90

- 26 -

14. A system according to any one of claims 10 to 13, in which the air pressure control means for driving the canister along the air tube comprises a blower which is connected to the air tube and is selectively operable to blow or suck air through the tube, the blower being connected to the air tube adjacent the near end of the TAU tube terminal (relative to the cashier terminal) via a non-return valve which permits air to be sucked from the tube but not blown into the tube, and being further connected to the air tube adjacent the far end of the TAU tube terminal via a non-return valve which permits air to be blown into the tube but not sucked therefrom.

15. A system according to any one of claims 10 to 14, in which the means for stopping the canister at the tube terminal is linked to the means for rotating the sleeve so that the sleeve is opened automatically after the canister reaches its predetermined position in the terminal.

0299U

14
SJS
SUBSTITUTE SHEET
OFFICE

United Kingdom
Patent Office

1/3

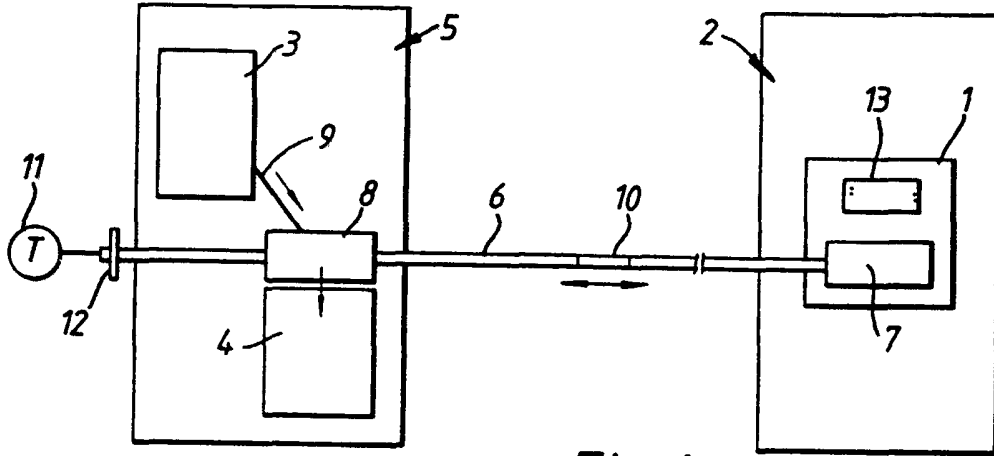

Fig. 1.

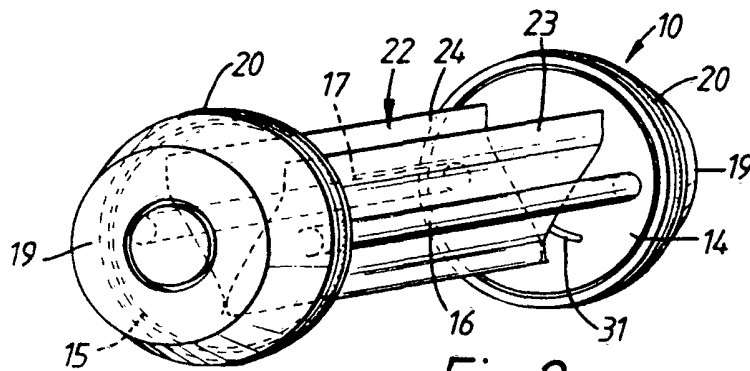

Fig. 2.

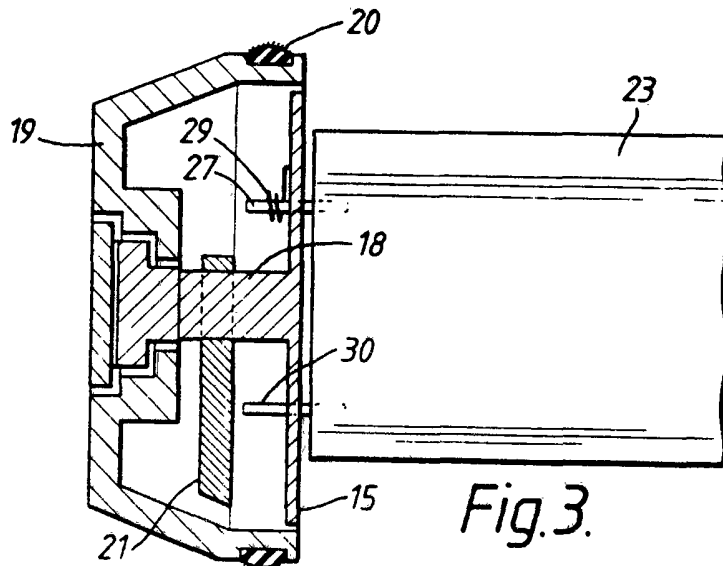

Fig. 3.

2/3

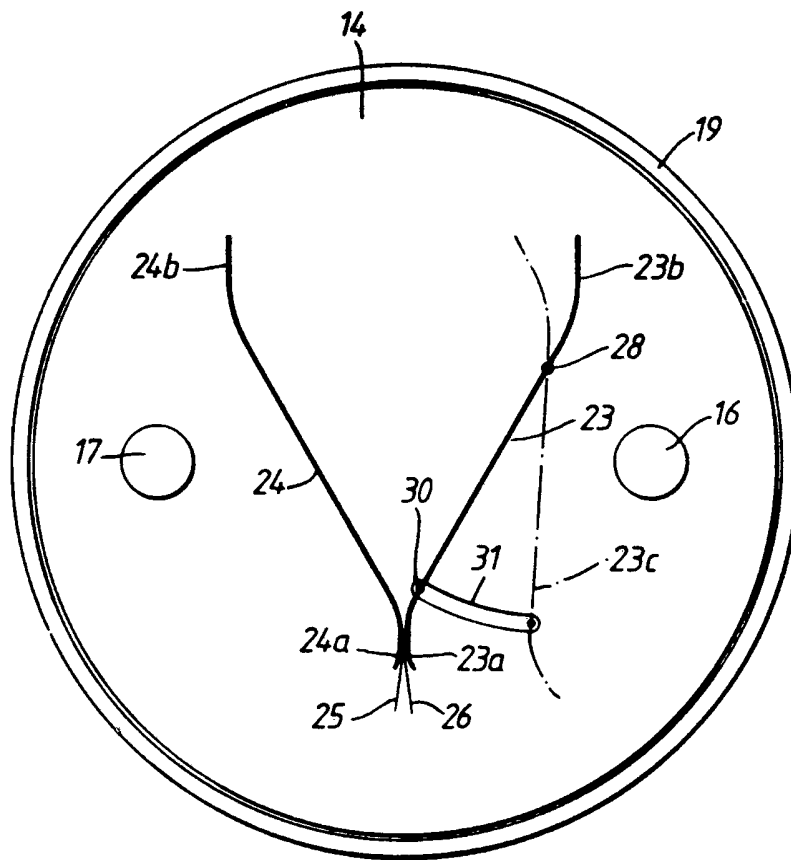

Fig.4.

3/3

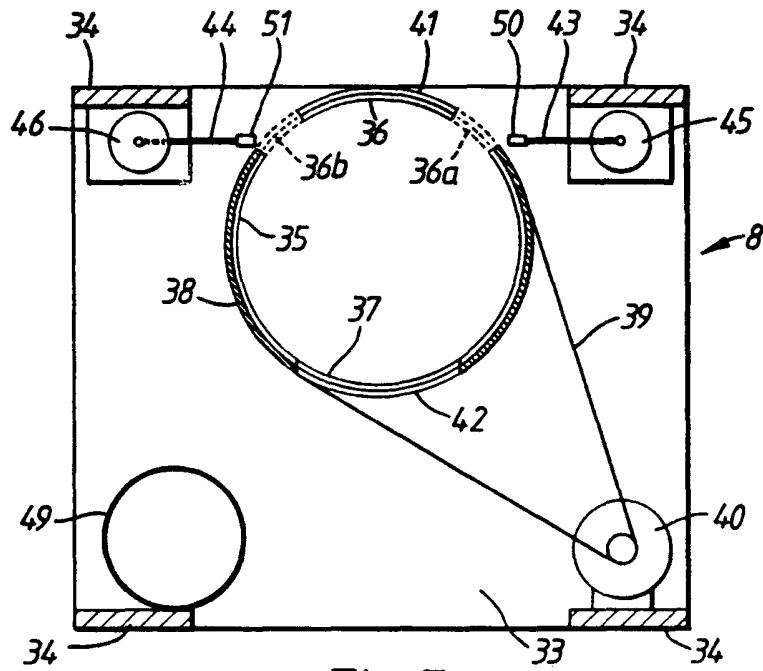

Fig. 5.

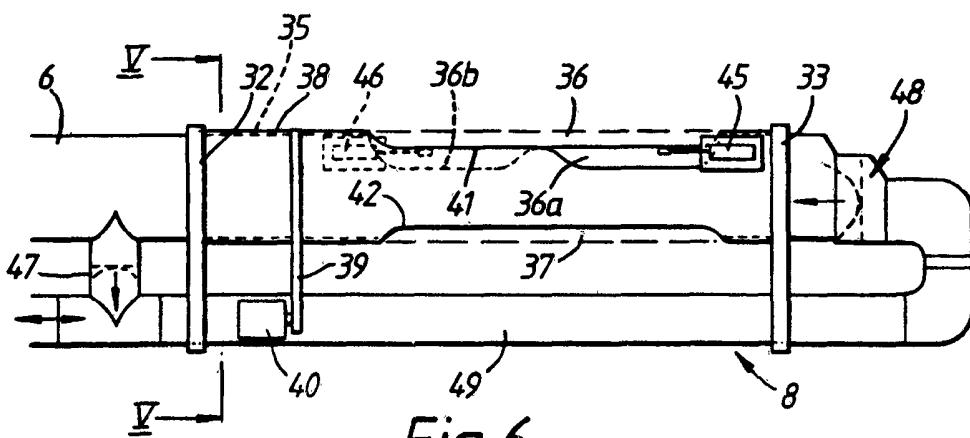
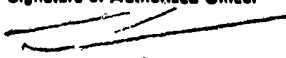

Fig. 6.

INTERNATIONAL SEARCH REPORT

International Application No **PCT/GB 89/00552**

I. CLASSIFICATION OF SUBJECT MATTER (if several classification symbols apply, indicate all) ⁶		
According to International Patent Classification (IPC) or to both National Classification and IPC		
IPC ⁴ : B 65 G 51/06, B 65 G 51/26, B 65 G 51/34		
II. FIELDS SEARCHED		
Minimum Documentation Searched ⁷		
Classification System	Classification Symbols	
IPC ⁴	B 65 G	
Documentation Searched other than Minimum Documentation to the extent that such Documents are included in the Fields Searched ⁸		
III. DOCUMENTS CONSIDERED TO BE RELEVANT⁹		
Category ⁹	Citation of Document, ¹¹ with indication, where appropriate, of the relevant passages ¹²	Relevant to Claim No. ¹³
X	US, A, 1492734 (MACLAREN) 6 May 1924, see the whole document	1-3
A	--	4,12
X	US, A, 1613471 (MACLAREN) 4 January 1927, see the whole document	1,3,4
A	--	2,7,8,12
A	EP, A, 0063691 (AUTELCA AG) 3 November 1982, see page 1, lines 1-8; page 5, lines 3- 12; page 8, line 28 - page 11, line 29; figures	1,11,12
A	US, A, 4113202 (UENO) 12 September 1978, see column 2, lines 12-52; figures	1,10,11
A	DE, A, 2717519 (BUHEL) 26 October 1978, see page 5, lines 1-4; page 8, line 27 - page 9, line 19; figures	12
A	US, A, 2698721 (VAN OTTEREN) 4 January 1955, see column 1, line 68 - column 2, line 66; figures 5-7	12,16
<p>⁹ Special categories of cited documents: ¹⁰</p> <p>"A" document defining the general state of the art which is not considered to be of particular relevance</p> <p>"E" earlier document but published on or after the international filing date</p> <p>"L" document which may throw doubts on priority claim(s) or which is cited to establish the publication date of another citation or other special reason (as specified)</p> <p>"O" document referring to an oral disclosure, use, exhibition or other means</p> <p>"P" document published prior to the international filing date but later than the priority date claimed</p> <p>"T" later document published after the international filing date or priority date and not in conflict with the application but cited to understand the principle or theory underlying the invention</p> <p>"X" document of particular relevance; the claimed invention cannot be considered novel or cannot be considered to involve an inventive step</p> <p>"Y" document of particular relevance; the claimed invention cannot be considered to involve an inventive step when the document is combined with one or more other such documents, such combination being obvious to a person skilled in the art.</p> <p>"Δ" document member of the same patent family</p>		
IV. CERTIFICATION		
Date of the Actual Completion of the International Search	Date of Mailing of this International Search Report	
23rd August 1989	19. 09. 89	
International Searching Authority	Signature of Authorized Officer	
EUROPEAN PATENT OFFICE	 T.K. WILLIS	

REC'D 20 SEP 1990

WIPO PCT

**PATENT COOPERATION TREATY
INTERNATIONAL PRELIMINARY EXAMINATION REPORT**

IDENTIFICATION OF THE INTERNATIONAL APPLICATION		Applicant's or Agent's File Reference W30658W0/19																																													
International Application No. PCT/GB 89/00552	International Filing Date 19 May 1989 (19.05.89)																																														
Receiving Office U K PATENT OFFICE	Priority Date Claimed 20 May 1988 (20.05.88)																																														
Applicant (Name) Tripmatic Limited et al																																															
BASIS OF REPORT																																															
<p>1. AMENDMENTS AND/OR RECTIFICATIONS* — The amendments and/or rectifications made before the International Preliminary Examining Authority in respect of the claims, the description, and/or drawings in the above-mentioned international application are annexed to this report.</p>																																															
<p>a. <input checked="" type="checkbox"/> This report has been established on the basis of the following application documents:</p>																																															
<table style="width: 100%; border: none;"> <tr> <td style="width: 40%;"><input type="checkbox"/> the application documents as filed</td> <td style="width: 20%;"></td> <td style="width: 20%;"></td> <td style="width: 20%;"></td> </tr> <tr> <td><input checked="" type="checkbox"/> description, pages 1-3, 5-20</td> <td>as originally filed</td> <td></td> <td></td> </tr> <tr> <td>description, pages 4</td> <td>filed with your letter of</td> <td>31.07.90</td> <td></td> </tr> <tr> <td>description, pages</td> <td>filed with your letter of</td> <td></td> <td></td> </tr> <tr> <td>description, pages</td> <td>filed with your letter of</td> <td></td> <td></td> </tr> <tr> <td><input checked="" type="checkbox"/> claim(s)</td> <td>as originally filed</td> <td></td> <td></td> </tr> <tr> <td>claim(s) 1-15</td> <td>filed with your letter of</td> <td>12.06.90</td> <td></td> </tr> <tr> <td>claim(s)</td> <td>filed with your letter of</td> <td></td> <td></td> </tr> <tr> <td>claim(s)</td> <td>filed with your letter of</td> <td></td> <td></td> </tr> <tr> <td><input checked="" type="checkbox"/> drawings, sheet/fig. 1/3-3/3</td> <td>as originally filed</td> <td></td> <td></td> </tr> <tr> <td>drawings, sheet/fig.</td> <td>filed with your letter of</td> <td></td> <td></td> </tr> </table>				<input type="checkbox"/> the application documents as filed				<input checked="" type="checkbox"/> description, pages 1-3, 5-20	as originally filed			description, pages 4	filed with your letter of	31.07.90		description, pages	filed with your letter of			description, pages	filed with your letter of			<input checked="" type="checkbox"/> claim(s)	as originally filed			claim(s) 1-15	filed with your letter of	12.06.90		claim(s)	filed with your letter of			claim(s)	filed with your letter of			<input checked="" type="checkbox"/> drawings, sheet/fig. 1/3-3/3	as originally filed			drawings, sheet/fig.	filed with your letter of		
<input type="checkbox"/> the application documents as filed																																															
<input checked="" type="checkbox"/> description, pages 1-3, 5-20	as originally filed																																														
description, pages 4	filed with your letter of	31.07.90																																													
description, pages	filed with your letter of																																														
description, pages	filed with your letter of																																														
<input checked="" type="checkbox"/> claim(s)	as originally filed																																														
claim(s) 1-15	filed with your letter of	12.06.90																																													
claim(s)	filed with your letter of																																														
claim(s)	filed with your letter of																																														
<input checked="" type="checkbox"/> drawings, sheet/fig. 1/3-3/3	as originally filed																																														
drawings, sheet/fig.	filed with your letter of																																														
<p>b. <input checked="" type="checkbox"/> The amendments resulted in the cancellation of the following sheets: 4, 21-26</p>																																															
<p>c. <input type="checkbox"/> This report has been established as if the amendments indicated on the cover sheet have not been made, unless, for the reasons indicated, they have been considered to go beyond the disclosure as filed.</p>																																															
2. PRIORITY*																																															
<p>a. This report has been established as if no priority has been claimed due to the failure to furnish within the prescribed time limit the requested:</p>																																															
<p><input type="checkbox"/> copy of the earlier application whose priority has been claimed.</p>																																															
<p><input type="checkbox"/> translation of the earlier application whose priority has been claimed.</p>																																															
<p>b. <input type="checkbox"/> This report has been established as if no priority has been claimed due to the fact that the priority claim has been found invalid.</p>																																															
<p>Thus, for the purposes of this report, the international filing date indicated above is considered to be the relevant date.</p>																																															
<p>* Where requestant sheets are annexed to this report, a translation of those requestant sheets must be furnished to the elected Office within the time limit applicable under PCT Article 36(1).</p>																																															

CLASSIFICATION OF SUBJECT MATTER (If several classification symbols apply, indicate all.)		
According to International Patent Classification (IPC) or to both National Classification and IPC		
IPC4: B65 G 51/06, B 65 G51/26, B65 G51/34		
REASONED STATEMENT AS TO CLAIMS MEETING CRITERIA OF NOVELTY (N), INVENTIVE STEP (IS) AND INDUSTRIAL APPLICABILITY (IA), AND CITATIONS AND EXPLANATIONS SUPPORTING SUCH STATEMENT		
CLAIM NUMBER	STATEMENT (CRITERIA)	CITATIONS AND EXPLANATIONS
1-15	YES (N, IS, IA)	<p>All claims meet the requirement of industrial applicability, novelty and inventive step.</p> <p>Thus, claim 1 is distinguished from the disclosure of US 1613471 in that the holder 5 and clip 9 in the U.S. document do not define a substantially V-shape trough into which bank notes can be received and retained between lower longitudinal edge portions at the root of the trough. Furthermore, too much modification would be required to achieve these arrangements.</p> <p>Claims 2-15 are dependent on claim 1.</p>

NON-WRITTEN DISCLOSURES ¹			
Kind of Non-Written Disclosure	Date of Written Disclosure referring to the Non-Written Disclosure	Date of Non-Written Disclosure	
CERTAIN PUBLISHED DOCUMENTS ¹⁰			
Application/Patent	Date of Publication	Filing Date	Priority Date (Valid Claim)
CERTAIN DEFECTS IN THE INTERNATIONAL APPLICATION ¹¹			
The following defects in the form or contents of the international application have been noted.			
CERTAIN OBSERVATIONS ON THE INTERNATIONAL APPLICATION ¹²			
The following observations on the clarity of the claims, description, and drawings or on the question whether the claims are fully supported by the description have been noted.			
CERTIFICATION			
Date Demand Submitted 19 DECEMBER 1989 (19.12.89)		Date of Completion of the International Preliminary Examination Report 9 th SEPTEMBER 1990 (09.09.90)	
International Preliminary Examining Authority U. K. PATENT OFFICE		Signature of Authorized Officer 