



- (51) International Patent Classification:
A61N 1/04 (2006.01)
- (21) International Application Number:
PCT/US2009/050429
- (22) International Filing Date:
13 July 2009 (13.07.2009)
- (25) Filing Language: English
- (26) Publication Language: English
- (30) Priority Data:
61/080,175 11 July 2008 (11.07.2008) US
61/134,827 14 July 2008 (14.07.2008) US
- (71) Applicant (for all designated States except US): GEP TECHNOLOGY, INC. [US/US]; 1175 Shady Pod Lane, Pleasanton, CA 94566 (US).
- (72) Inventor; and
- (75) Inventor/Applicant (for US only): KIM, Daniel, H. [US/US]; One Hermann Park Court, Apt. #933, Houston, TX 77021 (US).
- (74) Agents: PATTERSON, B., Todd et al.; Patterson & Sheridan, L.L.P., 3040 Post Oak Blvd. Suite 1500, Houston, TX 77056 (US).
- (81) Designated States (unless otherwise indicated, for every kind of national protection available): AE, AG, AL, AM, AO, AT, AU, AZ, BA, BB, BG, BH, BR, BW, BY, BZ, CA, CH, CL, CN, CO, CR, CU, CZ, DE, DK, DM, DO, DZ, EC, EE, EG, ES, FI, GB, GD, GE, GH, GM, GT, HN, HR, HU, ID, IL, IN, IS, JP, KE, KG, KM, KN, KP, KR, KZ, LA, LC, LK, LR, LS, LT, LU, LY, MA, MD, ME, MG, MK, MN, MW, MX, MY, MZ, NA, NG, NI, NO, NZ, OM, PE, PG, PH, PL, PT, RO, RS, RU, SC, SD, SE, SG, SK, SL, SM, ST, SV, SY, TJ, TM, TN, TR, TT, TZ, UA, UG, US, UZ, VC, VN, ZA, ZM, ZW.
- (84) Designated States (unless otherwise indicated, for every kind of regional protection available): ARIPO (BW, GH, GM, KE, LS, MW, MZ, NA, SD, SL, SZ, TZ, UG, ZM, ZW), Eurasian (AM, AZ, BY, KG, KZ, MD, RU, TJ, TM), European (AT, BE, BG, CH, CY, CZ, DE, DK, EE, ES, FI, FR, GB, GR, HR, HU, IE, IS, IT, LT, LU, LV, MC, MK, MT, NL, NO, PL, PT, RO, SE, SI, SK, SM,

[Continued on next page]

(54) Title: APPARATUS AND METHODS FOR MINIMALLY INVASIVE OBESITY TREATMENT

FIG. 2

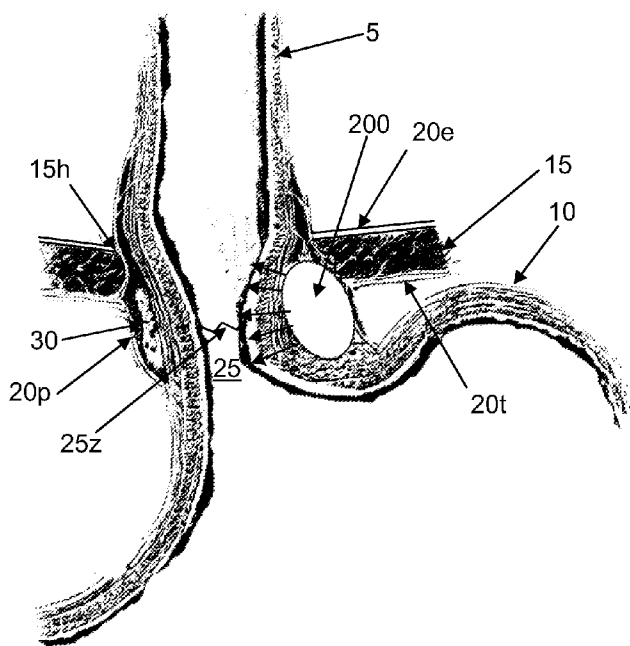

(57) Abstract: Apparatus and methods are provided for the effective and minimally invasive treatment of obesity. In one embodiment, a device for providing therapy to a patient includes an inflatable structure adapted and configured for positioning at least partially within a gastroesophageal (GE) space formed between an inner wall of a phrenoesophageal ligament (POL) and outer walls of the esophagus and cardiac orifice and an electrode structure adapted and configured for positioning at least partially within the GE space. In another embodiment, a method for treating a patient includes introducing an electrode at least partially into a gastroesophageal (GE) space formed between an inner wall of a phrenoesophageal ligament (POL) and outer walls of the esophagus and cardiac orifice and modulating tissue using the electrode.

TR), OAPI (BF, BJ, CF, CG, CI, CM, GA, GN, GQ, GW, ML, MR, NE, SN, TD, TG). **Published:**

— with international search report (Art. 21(3))

APPARATUS AND METHODS FOR MINIMALLY INVASIVE OBESITY TREATMENT

BACKGROUND OF THE INVENTION

Field of the Invention

[0001] The present invention generally relates to apparatus and methods for minimally invasive treatment of obesity.

Description of the Related Art

[0002] Obesity is a major health concern in many countries and is particularly prevalent in developed countries. Almost one-third of the adult American population is considered to be obese, while almost two-thirds of adult Americans are categorized as being obese or overweight. The number of overweight and obese Americans has continued to increase since 1960. Obesity is now an increasingly common health concern that affects many teenagers and children as well as adults.

[0003] Obesity is also a risk factor for a broad range of diseases and conditions, including diabetes, coronary artery disease, sleep apnea, gastro-esophageal reflux disease (GERD), and cancer of the breast, prostate and colon. As a result, obesity adds enormously to the costs of healthcare in the U.S.

[0004] Each year, obesity causes at least 300,000 excess deaths in the U.S., and healthcare costs of American adults with obesity amount to approximately \$100 billion. Furthermore, obese individuals may become victims of discrimination in employment and social settings leading to inferior lifestyle, lower socio-economic status, and possible psychological and mental health problems.

[0005] Treatment regimes for obesity have included various diets, exercise programs, and lifestyle counseling, as well as pharmaceutical compositions and surgery. Numerous surgical procedures for the treatment of obesity are known in the prior art. One surgical approach to obesity treatment is gastric bypass surgery, which leads to decreased nutrient absorption by the patient. Another approach to the treatment of obesity is the insertion of an intra-gastric balloon to mimic fullness of the stomach. A further approach is the application of a band around the stomach wall to

restrict gastric volume. Yet another approach is the insertion of an intraluminal filter or valve at the gastro-esophageal junction to restrict passage of food into the stomach. Still another approach is the direct electrical stimulation of the stomach wall to decrease the normal peristaltic motility of the stomach.

[0006] The procedures outlined above have generally been of limited value, and in addition have various disadvantages. For example, insertion of an intra-gastric balloon in the stomach is invasive and may have serious side effects, e.g., by interfering with the digestion of food. Similarly, various gastric bypass procedures, in which a portion of the gastro-intestinal tract is surgically excised, have led to under-nourished or malnourished patients, and furthermore such procedures are typically highly invasive and irreversible.

[0007] As can be seen, there is a need for apparatus, systems, and methods for the safe, reliable, cost-effective, and minimally invasive treatment of obesity.

SUMMARY OF THE INVENTION

[0008] The present invention provides apparatuses and methods for the effective and minimally invasive treatment of obesity. In one embodiment, a method for treating a patient, includes: introducing an electrode at least partially into a gastroesophageal (GE) space formed between an inner wall of a phrenoesophageal ligament (POL) and outer walls of the esophagus and cardiac orifice; and modulating tissue using the electrode.

[0009] In one aspect of the embodiment, the electrode is introduced substantially or wholly within the GE space. In another aspect, the method further includes securing the electrode to the POL. The electrode may be secured to an interior or exterior portion of the POL. In another aspect, the method further includes promoting a feeling of satiety in the patient during or after modulation. In another aspect, the tissue includes a portion of the diaphragm. The tissue may further include a portion of the nerve that innervates the diaphragm portion. In another aspect, the tissue includes a portion of a vagal nerve. In another aspect, the tissue includes a portion of a splanchnic nerve. In another aspect, the tissue includes a portion of a celiac ganglion. A ventral aspect of the diaphragm portion, vagal nerve, or celiac ganglion may be modulated.

[0010] In another aspect, the method further includes modulating tissue using the electrode provides a signal from the electrode towards an aspect of a neural structure that faces towards a portion of the POL used to support the electrode. The method may further include advancing the electrode within the GE space into a position adjacent a ventral aspect of a portion of the tissue. The method may further include passing a least a portion of the electrode out of the GE space towards a portion of the tissue. The method may further include passing at least a portion of the electrode in a dorsal direction out of the GE space towards a portion of the tissue. The method may further include passing at least a portion of the electrode out of the GE space towards a portion of the tissue without passing the electrode beyond a coronal plane passing through a portion of the aorta. The portion of the aorta may include a ventral aspect of the aorta. The portion of the aorta may include a dorsal aspect of the aorta.

[0011] In another aspect, the method further includes forming an opening in the POL, and thereafter introducing the electrode into the GE space through the opening. The method may further include laterally inserting a surgical instrument into the patient before forming the opening. The method may further include anteriorly inserting a surgical instrument into the patient before forming the opening. The electrode may be introduced endoscopically through a trocar. The method may further include posteriorly inserting a surgical instrument into the patient and thereafter forming the opening in the GE space. The instrument may include a guide wire and one or more dilators. In another aspect, the electrode is mounted on a paddle. In another aspect, the electrode is mounted on a steerable catheter. In another aspect, the electrode is introduced using an endoscope.

[0012] In another embodiment, a method for treating a patient, includes: approaching a portion of the phrenoesophageal ligament (POL) with an instrument; advancing an electrode along the instrument to a position adjacent the POL; and applying a electrical signal to tissue adjacent to the POL using the electrode. In one aspect of the embodiment, the method further includes supporting at least a portion of the electrode with the POL. At least a portion of the electrode may be adjacent to an outer or inner layer of the POL. In another aspect, the approaching step further includes advancing the instrument dorsally towards the POL. In another aspect, the approaching step further includes advancing the instrument ventrally towards the POL. In another aspect, the approaching step further includes advancing the

instrument laterally towards the POL.

[0013] In another aspect, the POL portion is superior to the diaphragm. The POL portion may be lateral of a spinal midline. In another aspect, the POL portion is inferior to the diaphragm. The POL portion may be lateral of a spinal midline. In another aspect, applying a signal includes applying a signal that modulates neural activity. In another aspect, applying a signal includes applying a signal that inhibits neural activity. In another aspect, applying a signal includes applying a signal that stimulates neural activity. In another aspect, the tissue adjacent to the POL includes a neural tissue. In another aspect, the neural tissue includes at least one of: a portion of a vagal nerve; a portion of splanchnic nerve; a portion of a celiac ganglion or a portion of a nerve that innervates a portion of a diaphragm. In another aspect, the tissue adjacent to the POL includes muscle tissue. In another aspect, the muscle tissue includes a diaphragm. In another aspect, the muscle includes a stomach.

[0014] In another embodiment, a method for treating a patient, includes: forming an opening in the phrenoesophageal ligament (POL); introducing a balloon through the opening and into a gastroesophageal (GE) space formed between an inner wall of the POL and outer walls of the esophagus and cardiac orifice; and inflating the balloon to provide therapy to the patient. In one aspect of the embodiment, the therapy includes at least partially restricting the esophagus and/or cardiac orifice in proximity to the balloon. In another aspect, the therapy includes: urging an electrode disposed at least partially within the GE space into closer proximity to a targeted neural structure and thereafter delivering an electrical signal to the targeted neural structure with the electrode. In another aspect, at least a portion of the balloon is disposed between diaphragm and the cardiac orifice and/or esophagus. Inflating the balloon may distend at least a portion of the diaphragm. Inflating the balloon may distend at least a portion of the cardiac orifice. Inflating the balloon may distend at least a portion of the esophagus. In another aspect, after inflating the balloon, at least a portion of the balloon is generally shaped like an ellipsoid, an egg, a cylinder, or a polyhedron.

[0015] In another aspect, the opening is formed by: advancing a surgical instrument towards the POL; and engaging the POL with the distal end of the instrument. The POL may be engaged by grasping the POL with the instrument. The POL may be further engaged by separating the POL from tissue within the GE

space. The POL may be separated before forming the opening. The POL may be engaged by applying a vacuum to the POL using the instrument. The POL may be engaged by advancing tines from the distal end of the surgical instrument and piercing the POL. In another aspect, the method further includes fastening the balloon to the POL.

[0016] In another aspect, the balloon includes a first wall having a first stiffness, a second wall having a second stiffness, and a partition, the first wall and the partition enclose a first chamber, the second wall and the partition enclose a second chamber, and the second stiffness is greater than the first stiffness. The first wall may exert pressure on the wall of the cardiac orifice and/or esophagus, and the second wall may be supported by the diaphragm. The first chamber may be in fluid communication with a first valve, the second chamber may be in fluid communication with a second valve, and the valves may provide for independent inflation of the chambers. In another aspect, the balloon is inflated to a first size, and the method further includes inflating the balloon to a second larger size after a period of time sufficient for the patient to become accustomed to the balloon.

[0017] In another aspect, the balloon is inflated until a balloon pressure reaches a predetermined pressure. In another aspect, the method further includes: inserting a pressure sensor into the esophagus and/or cardiac orifice to a position adjacent the balloon; and monitoring pressure of the balloon using the pressure sensor while inflating the balloon. Inflating the balloon may be performed until a predetermined pressure is measured by the pressure sensor that corresponds to a desired degree of luminal restriction. In another aspect, the therapy includes inflating the balloon to provide a degree of luminal restriction. The degree of luminal restriction may be provided in at least a portion of the esophagus. The degree of luminal restriction may be provided in at least a portion of the stomach.

[0018] In another aspect, the balloon is inflated to a first size, and the method further includes: injecting a contrasting agent into the esophagus and cardiac orifice; imaging at least a portion of the esophagus and the cardiac orifice; determining a diameter of the restriction of the esophagus and/or cardiac orifice using the image. In another aspect, the balloon further exerts pressure on the stomach fundus. In another aspect, the method further includes: inserting a trocar into a thorax or abdomen of the patient; and inserting a working catheter into the trocar, wherein: the

working catheter includes the balloon connected to a balloon catheter, and the balloon is inflated by injecting fluid into the balloon catheter. The working catheter may further include an endoscope. In another aspect, the esophagus and/or cardiac orifice lumen is restricted to a first diameter, thereby restricting a rate of food intake by the patient. In another aspect, the esophagus and/or cardiac orifice lumen is restricted to a first diameter, thereby facilitating esophageal closure. In another aspect, the esophagus and/or cardiac orifice lumen is restricted to a first diameter, thereby inhibiting or restricting reflux of stomach contents into the esophagus.

[0019] In another aspect, the method further includes modulating tissue using an electrode attached to the balloon. The tissue may include diaphragmatic muscle. The tissue may include a vagal nerve. The tissue may further include a splanchnic nerve and/or a celiac ganglion. At least two pairs of electrodes may be attached to the balloon and inflating the balloon may press a first pair against a vagal nerve and a second pair of the electrodes against a splanchnic nerve and/or a celiac ganglion. In another aspect, the method further includes: performing the inflating step until an electrode moves into closer proximity to a portion of a vagal nerve; a portion of a splanchnic nerve; a portion of a celiac ganglion or a portion of a nerve that innervates a portion of a diaphragm. The portion of the vagal nerve may include a ventral aspect of the vagal nerve; the portion of the splanchnic nerve may include a ventral aspect of the splanchnic nerve; or the portion of a celiac ganglion may include a ventral aspect of the celiac ganglion.

[0020] In another embodiment, a catheter assembly for insertion into a patient, includes: a working catheter; a balloon catheter disposed in the working catheter; and a balloon connected to the balloon catheter, inflatable by injection of fluid through the balloon catheter, and including a first wall having a first stiffness, a second wall having a second stiffness, and a partition, wherein the first wall and the partition enclose a first chamber and the second wall and the partition enclose a second chamber. In one aspect of the embodiment, at least a portion of an inflated shape of the balloon is an ellipsoid, an egg, a cylinder, or a polyhedron. In another aspect, the second stiffness is greater than the first stiffness. In another aspect, the second stiffness is substantially greater than the first stiffness. In another aspect, the balloon catheter includes a first lumen in fluid communication with the first chamber and a second lumen in fluid communication with the second chamber.

[0021] In another aspect, the assembly further includes: a first valve is in fluid communication with the first chamber; and a second valve is in fluid communication with the second chamber, wherein operation of the valves provides independent fluid communication with the chambers. In another aspect, the balloon is made from or coated with a biocompatible material. In another aspect, the assembly further includes a wire preformed into a hook, wherein the wire is operable between: a first position where the wire is elastically restrained inside the working catheter, and a second position where the wire returns to the preformed hook as the wire is extended from the working catheter. In another aspect, the assembly further includes an inner catheter disposed between the hook and the balloon catheter. In another aspect, the assembly further includes an electrode attached to an outer surface of the balloon. In another aspect, the assembly further includes: an adapter connecting the balloon catheter and the balloon; and a lug extending from an outer surface of the adapter.

[0022] In another embodiment, a device for providing therapy to a patient, includes: an inflatable structure adapted and configured for positioning at least partially within a gastroesophageal (GE) space formed between an inner wall of a phrenoesophageal ligament (POL) and outer walls of the esophagus and cardiac orifice; and an electrode structure adapted and configured for positioning at least partially within the GE space. In one aspect of the embodiment, when the inflatable structure is inflated at least a portion of the inflatable structure is shaped like an ellipsoid, an ovoid, a cylinder, a polyhedron or a portion of a curve. In another aspect, the electrode structure comprises flexible base that is sufficiently flexible to follow at least a portion of the interior shape of the GE space. In another aspect, at least a portion of the electrode structure is attached to the inflatable structure.

[0023] In another aspect, the inflatable structure has a length selected to be less than the perimeter of the esophageal wall within the GE space. In another aspect, the inflatable structure has a length selected such that in use within the GE space, the inflatable structure circumscribes less than half the perimeter of the esophageal wall within the gastroesophageal (GE) space. In another aspect, the electrode structure has a length selected to be less than the perimeter of the esophageal wall within the GE space. In another aspect, the electrode structure has a length selected such that in use within the GE space, the electrode structure circumscribes less than half the perimeter of the esophageal wall within the GE space. In another aspect, the

respective sizes of the electrode structure and the inflatable structure are selected such that both structures may be within the GE space without contacting one another. In another aspect, the electrode structure has a length selected such that in use within the GE space, the electrode structure circumscribes a first portion of the perimeter of the esophageal wall within the GE space and the inflatable structure has a length selected such that in use within the GE space the inflatable structure circumscribes a second portion of the perimeter of the esophageal wall within the GE space without overlapping with the first portion.

[0024] In another embodiment, a method of treating a patient, includes: positioning an electrode at or near a portion of the phrenoesophageal ligament (POL); advancing the electrode towards a neural target in proximity to the POL; and applying an electrical signal to the neural target using the electrode. In one aspect of the embodiment, advancing the electrode includes advancing the electrode towards a ventral aspect of the neural target. In another aspect, advancing the electrode includes advancing the electrode towards the neural target without passing through a coronal plane passing through a portion of the aorta. The coronal plane may pass through a portion of the aorta passes through a ventral aspect of the aorta. The coronal plane may pass through a portion of the aorta passes through a dorsal aspect of the aorta.

[0025] In another aspect, the neural target comprises at least a portion of a vagal nerve, a splanchnic nerve, a celiac ganglion or a nerve that innervates a portion of a diaphragm. In another aspect, after positioning the electrode at or near a portion of the POL, at least a portion of the electrode is positioned at least partially within a gastroesophageal (GE) space formed between an inner wall of the POL and an outer wall of the esophagus and an outer wall of the stomach. In another aspect, advancing the electrode includes advancing the electrode towards the neural target without passing through a coronal plane positioned at a ventral aspect of a vertebral body adjacent the POL. In another aspect, advancing the electrode towards a neural target in proximity to the POL further includes: advancing the electrode in a lateral direction away from a portion of the POL. In another aspect, advancing the electrode towards a neural target in proximity to the POL further includes: advancing the electrode in a dorsal direction away from a portion of the POL. In another aspect, advancing the electrode towards a neural target in proximity to the POL further

includes: advancing the electrode in a cephalad direction away from a portion of the POL. In another aspect, advancing the electrode towards a neural target in proximity to the POL further includes: advancing the electrode in a caudal direction away from a portion of the POL.

BRIEF DESCRIPTION OF THE DRAWINGS

[0026] Figure 1 is a view of a portion of a human gastro-intestinal (GI) tract. Figure 1A is a cross section of the cardiac orifice/esophagus.

[0027] Figure 2 is a view of the GI tract portion where the cardiac orifice and/or esophagus are being restricted by a balloon, according to one embodiment of the present invention. Figure 2A is a cross section of the restricted cardiac orifice/esophagus.

[0028] Figure 3A is a cross section of the balloon inflated to a first size. Figure 3B is a cross section of the balloon inflated to a smaller second size.

[0029] Figures 4-8 illustrate acts of a method for implanting the balloon, according to another embodiment of the present invention. Figures 4A and 4B illustrates locations of trocars for catheter insertion. Figure 5 illustrates placement of the working catheter. Figures 6A-C illustrate deployment of hooks from the working catheter. Figures 7A-C illustrate engagement and tearing of the POL for insertion of the balloon. Figures 8A and 8B illustrate insertion of the balloon into the POL opening and inflation of the balloon against the cardiac orifice/esophageal wall.

[0030] Figures 9A-9D illustrate an optional additional anchor for retaining the balloon in the GE space.

[0031] Figures 10A-11C illustrate a bi-chamber balloon, according to another embodiment of the present invention.

[0032] Figures 12A and 12B illustrate a method for measuring pressure exerted on the esophagus/cardiac orifice by different inflation levels of the balloon.

[0033] Figures 13A-13D illustrate a method for determining the diameter of the cardiac orifice/esophagus at different inflation levels of the balloon using a barium swallow.

[0034] Figures 14A-14B illustrate an additional use for the balloon in treating obesity, according to another embodiment of the present invention.

[0035] Figures 15A, 15C, and 15D illustrate a method for implanting an electrode 1560 for treating obesity, according to another embodiment of the present invention. Figure 15B illustrates an alternate approach.

[0036] Figures 16A and 16B illustrate a neuromodulator.

[0037] Figure 17 illustrates an alternative placement of the paddle electrode, according to another embodiment of the present invention.

[0038] Figures 18A and 18B illustrate implanting a balloon electrode, according to another embodiment of the present invention.

[0039] Figures 19A and 19B illustrate the electrode assembly in deflated and inflated positions, respectively.

[0040] Figures 20A and 20B illustrate an alternative placement of the balloon electrode, according to another embodiment of the present invention.

[0041] Figures 21A-H illustrate an alternative method for implanting the balloon electrode, according to another embodiment of the present invention.

[0042] Figures 22A and 22B are views of a portion of the GI tract illustrating possible approaches for the posterior insertion of Figures 21A-H.

[0043] Figures 23A-23F illustrate posterior implantation of a catheter electrode 2350, according to another embodiment of the present invention.

[0044] Figure 24A illustrates the spinal needle. Figure 24B illustrates the catheter electrode.

[0045] Figures 25A and 25B illustrate posterior endoscopic implantation of the catheter electrode, according to another embodiment of the present invention.

[0046] Figures 26A and 26B illustrate a distal end of the endoscope tube.

[0047] Figures 27A and 27B illustrate posterior endoscopic implantation of the balloon electrode, according to another embodiment of the present invention.

DETAILED DESCRIPTION OF THE INVENTION

[0048] The detailed description that follows is not to be taken in a limiting sense, but is made primarily for the purpose of illustrating the general principles of the various aspects of the present invention. The scope of the invention is best defined by the claims appended hereto.

[0049] Figure 1 is a view of a portion of a human gastro-intestinal (GI) tract. Figure 1A is a cross section of the GI tract. The GI tract includes the esophagus 5, the stomach 10, the diaphragm 15, and the cardiac orifice 25. The histology change between esophageal tissue and gastric tissue occurs at the z-line 25z. The esophagus 5 passes through an opening 15h of the diaphragm 15, known as the esophageal hiatus 15h. Proximately above the hiatus 15h, the esophagus 5 is anchored to the diaphragm 15 by an upper limb of the phrenoesophageal ligament (POL) 20p. The POL 20p is formed from two closely applied layers including a layer derived from endothoracic fascia 20e and a layer derived from transversalis fascia 20t. A lower limb of the POL 20p attaches to the stomach 10 proximately below the hiatus 15h. A gastroesophageal (GE) space 30 is formed between an inner wall of the POL 20p and outer walls of the esophagus 5 and cardiac orifice 25. The gastroesophageal (GE) space 30 is filled with adipose tissue and traversed by blood vessels.

[0050] Figure 2 is a view of the GI tract portion where the cardiac orifice 25 and/or esophagus 5 are being restricted by an inflatable member, such as a balloon 200, according to one embodiment of the present invention. Figure 2A is a cross section of the restricted cardiac orifice/esophagus 25,5. The balloon 200 has been implanted sub-fascially within the GE space 30 at the cardiac orifice/esophagus 25,5 proximate to the diaphragm 15. The balloon 200 has been implanted proximately below the diaphragm, but an end of the balloon 200 extends between the cardiac orifice/esophagus wall and the diaphragm 15 into the hiatus 15h to retain the balloon in place. Alternatively, the balloon 200 may be implanted anywhere along the GE space 30, such as at the diaphragm 15 or proximately above the diaphragm. The balloon 200 has been inflated by injecting an inflation fluid into the balloon 200. The inflation fluid may be a liquid, such as physiological saline or other aqueous liquids, a gel, a gas, a polymer, a biocompatible material, or any suitable filling material and combinations thereof. The balloon 200 may include a wall made from an extensible

material enclosing a chamber. The material may be a biocompatible material or the wall may be coated with a biocompatible material. The extensible material may be a polymer, such as an elastomer or a thermoplastic. When inflated, the shape of the balloon 200 may be an ellipsoid (i.e., a prolate), an egg, a cylinder, a polyhedron (i.e., rectangular prism) or any suitable shape. The balloon 200 may also have a contour or wedged portion to conform to the esophagus/cardiac orifice 5,25.

[0051] The wall may have a port formed therethrough for connection to a balloon catheter 205. The balloon catheter 205 may be connected to a syringe or pump for injection of the inflation fluid into the balloon chamber. Inflation of the balloon 200 exerts pressure on a portion of the cardiac orifice/esophagus wall, thereby restricting the cardiac orifice/esophagus lumen. Restriction of the cardiac orifice/esophagus lumen may be accomplished without surrounding the cardiac orifice/esophagus because of a reactionary pressure or force exerted on a face of the balloon distal from the cardiac orifice/esophagus by the diaphragm 15 and/or a reactionary pressure or force exerted on the cardiac orifice/esophagus wall by the diaphragm 15. In one embodiment, the inflated balloon is in contact with less than an entire circumference of the cardiac orifice/esophagus, preferably, less than half of the circumference. Without being bound by theory, it is believed that restriction of the cardiac orifice/esophagus lumen may reduce the rate at which the patient can consume food, thereby giving the patient's stomach more time to signal the patient's brain that the patient has consumed enough food. Restriction of the cardiac orifice/esophagus lumen may further require the patient to chew food more thoroughly and consume more fluids with meals, thereby further reducing the patient's caloric intake. As such, the balloon 200 is useful for treating obesity. Restriction of the cardiac orifice/esophagus lumen may also prevent or inhibit reflux of stomach contents into the esophagus, thereby preventing or treating gastro-esophageal reflux disease (GERD).

[0052] Figure 3A is a cross section of the balloon 200 inflated to a first size. Figure 3B is a cross section of the balloon 200 inflated to a smaller second size. The balloon catheter 205 may remain in the patient after implantation of the balloon 200 so that inflation of the balloon may be adjusted post-implantation. For example, the balloon 200 may be inflated to the second smaller size after initial implantation. The patient may then become accustomed to the smaller size for a period of time, such as

one week to a few months before the size of the balloon is further increased to the first larger size. Further, the optimal size of the balloon 200 may vary according to an individual patient so that the optimal size may have to be determined iteratively.

[0053] Figures 4-8 illustrate acts of a method for implanting the balloon 200, according to another embodiment of the present invention. Figures 4A and 4B illustrates locations of one or more trocars 405, 410 for catheter insertion. The trocars 405, 410 may be located in the abdomen. Alternatively, the trocars 405, 410 may be located in the thorax, especially for the alternative where the balloon is implanted above the diaphragm. A first trocar 405 may be inserted for providing a channel for an endoscope (not shown) and a second trocar 410 may be inserted for providing a channel for a working catheter 500. Alternatively, the working catheter 500 may incorporate the endoscope or the endoscope may be omitted so that only one trocar 405 is required.

[0054] Figure 5 illustrates placement of the working catheter 500. The catheter 500 may be inserted until a distal end is located between the stomach 10 and the diaphragm 15 proximate to the POL 20p. Alternatively, as discussed above, the balloon 200 may be located above the diaphragm 15. In this alternative, the catheter 500 may be located proximately above the diaphragm.

[0055] Figures 6A-C illustrate deployment of hooks 505 from the working catheter 500. Figures 7A-C illustrate engagement and tearing of the POL 20p for insertion of the balloon 200. The working catheter 500 may include an outer wall, one or more gripping devices such as hooks 505, an inner catheter 510, and the balloon catheter 205. The outer wall may be made from a rigid material, such as a polymer, such as a thermoset or thermoplastic, such as polyvinylchloride (PVC). The balloon catheter 205 may be disposed in the inner catheter lumen 515. The hooks 505, inner catheter 510, and balloon catheter 205 may be concentrically or eccentrically arranged within the working catheter 500. Alternatively, as discussed above, the working catheter 500 may also include the endoscope. The inner catheter 510 may serve to protect the balloon catheter from the hooks.

[0056] The hooks 505 may be connected to a sleeve (not shown) extending through the working catheter 500 so that the hooks may be manually operated from outside the patient. The hooks 505 may be made from a ductile material, such as a

metal or alloy, such as stainless steel or titanium. The hooks 505 may also be made from wire and have distal ends that taper to a sharp point. In one embodiment, the hooks are made from a shape memory metal or alloy. An end portion of each hook 505 may be plastically deformed into a curved shape so that when the hooks are extended from the working catheter, the end portions return to the curved shape and grasp the POL 20p. The POL 20p may then be separated from the GE space tissue by pulling and/or rotating the working catheter 500. Once an opening in the POL 20p is formed, the hooks 505 may be withdrawn back into the working catheter 500 or sleeve, thereby elastically returning them to a straight or substantially straight position.

[0057] Figures 8A and 8B illustrate insertion of the balloon 200 into the POL opening and inflation of the balloon against the cardiac orifice/esophageal wall. The balloon 200 and a distal portion of the balloon catheter 205 are pushed through and exit the working catheter 500 into the POL opening. A syringe or pump connected to a proximate end of the balloon catheter 205 is operated to inflate the balloon 200, thereby restricting the cardiac orifice/esophagus lumen. The working catheter 500 may then be withdrawn from the patient. A portion of the balloon catheter 205 may be left in the patient for adjusting inflation of the balloon, as discussed above. Depending on the size, shape, and placement of the balloon, inflation of the balloon may be sufficient to retain the balloon 200 into place.

[0058] Figures 9A-9D illustrate an optional additional anchor for retaining the balloon 200 in the GE space 30. An adapter 205 may connect the balloon 200 to the balloon catheter 205. One or more lugs 215 may extend from an outer surface of the adapter 205. Each lug 215 may be engaged by a respective hook 220. The hooks 200 may be made from one of the materials discussed above with respect to the hooks 505. The hooks 220 may be plastically formed into a coil shape and elastically restrained into a hook shape so that when the working catheter 500 is removed, the hooks are released and return to the coil shape, thereby anchoring the adapter and the balloon to the POL. Alternatively, the hooks 220 may be subsequently crimped into a coil. Alternatively, the adapter may be sutured or stapled to the fascia instead of using the hooks.

[0059] Figures 10A-11C illustrate a bi-chamber balloon 1000, according to another embodiment of the present invention. The bi-chamber balloon 1000 may include a

first wall 1005, a second wall 1010, a partition 1015, a catheter 1030, and an adapter 1035. The walls 1005, 1010 enclose a chamber. The walls 1005, 1010 may be made from an extensible material enclosing a chamber. The material may be a biocompatible material or the wall may be coated with a biocompatible material. The extensible material may be a polymer, such as an elastomer or a thermoplastic. When inflated, the shape of the balloon may be an ellipsoid (i.e., a prolate), an egg, a cylinder, a polyhedron (i.e., rectangular prism) or any suitable shape. Alternatively, the balloon 1000 may have any suitable number of chambers including three or more chambers.

[0060] The partition 1015 divides the chamber into a first chamber 1005a and a second chamber 1010a. The first wall 1005 has a first stiffness and the second wall 1010 and has a second stiffness. The first stiffness may be less than or substantially less than the second stiffness. The different stiffness may be accomplished by using different materials, different thickness, materials with different durometers, or combinations thereof. For example, the first wall 1005 may be made from an elastomer having a low amount of cross-linking and the second wall 1010 may be made from an elastomer having a higher amount of cross-linking. In another example, the first wall 1005 may be made from an elastomer and the second wall 1010 may be made from a thermoplastic. The partition 1015 may be a composite of the first and second walls bonded together (each wall is a separate balloon) or may be made from only one of the first and second materials. In another embodiment, the bi-chamber balloon 1000 may be formed by adjoining two single chamber balloons.

[0061] The balloon 1000 may be oriented so that the first wall 1005 faces the cardiac orifice/esophagus and the second wall faces the diaphragm 15 and/or stomach 10. Placement of the balloon 1000 in this manner encourages the first wall 1005 to expand toward the cardiac orifice/esophagus and discourages the first wall from expanding toward the more rigid second wall. The second wall may further be supported by the POL 20p, the stomach 10, and/or the diaphragm 15. The stiffness of the second wall 1010 may further be selected so that it is greater or substantially greater than the stiffness of the cardiac orifice/esophagus.

[0062] The balloon catheter 1025 may include a first lumen for the first chamber and a second lumen for the second chamber. The lumens may be arranged concentrically or eccentrically. The adapter 1035 connects the balloon catheter 1025

to the second wall 1010 and provides fluid communication between the second lumen and the second chamber. The catheter 1030 is connected to the adapter 1025 and a port formed through the partition 1015 and provides fluid communication between the first lumen and the first chamber. A valve manifold 1050 connects to a proximate end of the balloon catheter and also connects to a pump or syringe. The valve manifold may be coupled to the balloon catheter using an injection port. The injection port may be positioned outside a patient's body or inside the skin to facilitate attachment of the valve manifold 105. The valve manifold includes a first valve having a first button 1055 and a second valve having a second button 1060. Actuation of the first button provides fluid communication between the pump or syringe and the first chamber and actuation of the second button 1060 provides fluid communication between the second chamber and the pump or syringe. The valves may be biased so that non-actuation of a respective button closes the respective valve. Figures 11A and 11C illustrate different inflation sizes of the first chamber while the inflation size of the second chamber is constant. The bi-chamber balloon 1000 may be used with any of the methods, discussed above, for the balloon 200.

[0063] Figures 12A and 12B illustrate a method for measuring pressure exerted on the cardiac orifice/esophagus by different inflation levels of the balloon 200/1000. A pressure sensor 1200 connected to a catheter 1205 is inserted down the patient's throat until the pressure sensor is in alignment with the balloon. The catheter includes wires providing electrical and data communication between the pressure sensor and a display (not shown) outside of the patient. The balloon may then be inflated until it exerts a predetermined pressure on the cardiac orifice/esophagus. Alternatively or additionally, an endoscope may be used to view the restricted cardiac orifice/esophagus and the pressure sensor 1200 may include a light to facilitate viewing by the endoscope. Alternatively, the restricted cardiac orifice/esophagus may be gauged by insertion of catheters of increasing outer diameters until the catheter is obstructed.

[0064] Figures 13A-13D illustrate a method for determining the diameter of the cardiac orifice/esophagus at different inflation levels of the balloon using a barium swallow. The balloon may be inflated to a first size. The patient may be then given a barium sulfate suspension to drink. Fluoroscopy images are taken as the barium suspension is swallowed. As the patient swallows the barium suspension, it coats the

esophagus and cardiac orifice walls with a thin layer of the barium which is visible to x-rays. The barium coat enables the hollow structures of the esophagus and/or cardiac orifice to be imaged. The balloon may be then inflated to a second larger size and the barium swallow repeated until the cardiac orifice/esophagus is restricted to a predetermined diameter. Alternatively, the restricted cardiac orifice/esophagus may be imaged using an MRI machine.

[0065] Figures 14A-14B illustrate an additional use for the balloon 200/1000 in treating obesity, according to another embodiment of the present invention. The balloon 200/1000 may be positioned and/or sized to additionally exert pressure on the stomach fundus 10a. While not wishing to be bound by theory, it is believed that exertion of pressure on the stomach fundus may reduce Ghrelin production, thereby reducing the patient's appetite. The pressure exerted may also act as the stimuli for the fundus 10a to signal the brain that the stomach is full. In another embodiment, the balloon may be further divided into three chambers. For example, the second chamber may be partitioned into second and third chambers where the third chamber faces the fundus. In this alternative, the first and third walls may have a lower or substantially lower stiffness than the second chamber and be independently inflated so that respective pressures exerted on the cardiac orifice and the fundus may be independently controlled.

[0066] In another alternative embodiment (not shown), one or more electrodes may be attached to an outer surface of the balloon so that inflation of the balloon causes the electrodes to contact nerve tissue of the patient. Wires may extend from the electrode into an additional lumen of the balloon catheter. The wires may provide electrical communication between the electrodes and a neuro-modulator. Electrical contact between the electrodes and the nerve tissue allows one or more electrical signals to be applied to the nerve tissue, wherein the electrical signals are sufficient to electrically neuromodulate the nerve tissue. For example, the nerve tissue may comprise at least one vagal trunk (i.e. the anterior and/or posterior vagal trunk) of the vagus nerve. For example, the electrical signals may at least partially block neural impulses in nerve tissue that innervates the stomach, such that the patient experiences decreased gastric motility, decreased gastric enzyme production, and/or decreased gastric acid production. In another embodiment, the electrical signals may stimulate the transmission of neural impulses, e.g., in nerve tissue that innervates the

diaphragm, such that the patient experiences a sensation of satiety or fullness.

[0067] In one embodiment, the procedure for implanting the balloon into the GE space may be as follows. Initially, a working catheter is inserted through the trocar to a location between the stomach and the diaphragm. Then, the sleeve retaining the hooks is actuated to push the hooks out of the working catheter and grasp the POL. The sleeve is pulled/twisted to separate the POL from the GE space tissue and form an opening in the POL. In another embodiment, the working catheter is pulled back to separate the POL from the GE space tissue. After separation, a puncture tool is inserted through the working catheter to create an opening in the POL for the insertion of the balloon. In another embodiment, the balloon puncture tool may be provided on the balloon, the hook sleeve, or the working catheter. The puncture tool is retrieved after forming the opening. Thereafter, the balloon is inserted through the opening to the proper location for implantation. The balloon may be guided by the inner catheter. In another embodiment, the inner catheter may be pre-positioned adjacent the puncture tool so that the entire process may be performed in one trip. After being placed at the proper location, the balloon is inflated to exert a pressure on one portion of the esophagus/cardiac orifice, thereby constricting the lumen in the esophagus/cardiac orifice. Additionally, the balloon may be inflated and/or positioned such that the balloon may also apply a pressure against the stomach. The inflated balloon may be anchored to the POL using hooks, staples, or sutures. After inflation, the inner catheter, the sleeve, and the working catheter are retrieved. The balloon catheter remains and is provided with an injection port that may be attached to the skin, either internally or externally. The valve manifold may connect to the injection port for inflation or deflation of the balloon.

[0068] Figures 15A, 15C, and 15D illustrate a method for implanting an electrode 1560 for treating obesity, according to another embodiment of the present invention. Figure 15A is a sectional view of a patient cut through the diaphragm 15. Figures 15C and 15D are isometric views of a portion of the GI tract. A catheter 1540 may be inserted laterally (Figure 15A) adjacent or through the diaphragm 15 and through the POL 20p at a location so that the electrode may be inserted between the aorta 1510a (next to the vertebral column 1505v) and the esophagus/cardiac orifice 5,25. The catheter may include hooks for tearing an opening through the POL, as discussed above with reference to Figures 6A-7C. Alternatively, the catheter 1540 may be

inserted anteriorly (Figure 15B) using using one or more trocars 405,410 (see Figures 4A and 4B). The catheter 1540 may be inserted through the POL 20p between the diaphragm 15 and the esophagus/cardiac orifice 5,25. An electrode assembly 1550 may then be inserted through catheter 1540 and into the GE space 30.

[0069] The electrode assembly 1550 may include a lead conduit 1555 connected to a paddle electrode 1560. The electrode assembly 1550 may be inserted until the paddle electrode 1560 is received at least partially, substantially, or wholly within the GE space 30. One or more pairs of electrodes 1561,1562 of the paddle electrode 1560 may contact or be closely proximate to the posterior vagal trunk 1515b, thereby providing electrical communication between the posterior vagal trunk and the electrodes. The paddle electrode 1560 may be located so that a first electrode pair 1561 proximate the lead conduit is in contact or close proximity with the posterior vagal trunk. Additionally, the paddle electrode or lead conduit may be secured to the POL 20p, such as discussed above with respect to Figures 9B and 9D. Alternatively or additionally, the paddle electrode may be located in the GE space so that the electrodes are in close proximity or contact with diaphragmatic muscle so that minor nerves embedded in the muscle may be modulated. The anterior vagal trunk 1515a, spinal cord 1505c, and vena cava 1510v are also illustrated. Alternatively, the catheter may be a dilator inserted using a guide wire and one or more dilators as discussed below.

[0070] Figures 16A and 16B illustrate a neuromodulator 1590. The electrode assembly 1550 may be part of the neuromodulator 1590. The neuromodulator 1590 may further include a generator 1570. The generator 1570 may be implanted in the patient's body, such as in a pocket formed by the implanting surgeon just below the skin in the abdomen. The generator 1570 may be in electrical communication with the pairs of electrodes via lead wires housed in the lead conduit. The generator may be operable to deliver a signal to the posterior vagal trunk 1515b, thereby stimulating the nerve and promoting a feeling of satiety. Alternatively, the generator 1570 may deliver the signal to the posterior vagal trunk 1515b to inhibit or block the nerve.

[0071] The generator 1570 may include a housing, a microprocessor controller, a battery, an inverter or pulser, an antenna, and a transceiver. The housing may be sealed and made from a biocompatible material, such as titanium. The controller may operate the inverter or pulser to deliver the output signal according to predetermined

instructions. The controller may be reprogrammed by wireless communication with an external computer (not shown) via the antenna and receiver. The generator may further include a battery charger operable to generate electricity from wireless signals and recharge the battery. Alternatively, the generator may be worn by the patient externally and the lead conduit may extend percutaneously to the implanted electrodes. Alternatively, the generator may include only a housing, an antenna, a receiver, and an RF generator and deliver the signal to the electrodes when powered wirelessly, analogously to a passive RFID tag. The inverter or pulser may supply the signal to the electrodes and may supply a pulse or sinusoidal wave. A voltage, frequency, and/or current of the signal may be varied. For example, to stimulate the vagal nerve, the pulser may deliver pulses having a width of 0.05-1.5 ms, a current of 0.1-1.5 mA, a frequency of 5-150 Hz for a period of 300-10,000 sec.

[0072] The other pair 1562 of electrodes may be used as sensors so that the modulator controller may detect natural activity along the vagal nerve. The controller may modulate the vagal nerve in response to detected activity, such as that indicative of eating. Each electrode pair 1561, 1562 may be in communication with the generator via a respective pair of lead wires. Alternatively, an intensity of the pulses may be increased so that the electrode pair 1561 also modulates the diaphragmatic muscle, splanchnic nerve and/or the celiac ganglia.

[0073] Figure 17 illustrates an alternative placement of the paddle electrode 1560, according to another embodiment of the present invention. The paddle electrode 1560 may be implanted so that the first electrode pair is in close proximity or contact with the posterior vagal nerve and the second electrode pair is in close proximity or contact with the left splanchnic nerve 1520a, celiac ganglia 1520, and/or right splanchnic nerve 1520b. In this manner, the modulator controller may selectively modulate (i.e., stimulate or block) the anterior vagal nerve 1515b by energizing the first electrode pair, thereby creating/blocking a parasympathetic response or the celiac ganglia/splanchnic nerves by energizing the second electrode pair, thereby creating/blocking a sympathetic response, as desired to treat obesity or other eating disorders, such as bulimia and anorexia. In order to accomplish electrical communication with vagal and splanchnic/cealic ganglion, the paddle electrode may be disposed partially, within the GE space 30 so that the first electrode pair is in contact/close proximity with the vagal nerve and partially through the POL so that the

second electrode pair is in close proximity/contact with the splanchnic nerve/cealic ganglion.

[0074] Alternatively, the paddle electrode may be disposed substantially or wholly within the GE space so that the second pair is only in close proximity to the splanchnic nerve/cealic ganglion. Alternatively, the paddle electrode may be wholly disposed along an exterior surface of the POL or secured and/or supported to/from the POL so that the electrode pair is contact/close proximity with the splanchnic nerve/cealic ganglion or other adjacent tissue. Alternatively, the paddle electrode may be in electrical communication with only one of the splanchnic nerves, both of the splanchnic nerves, and/or the cealic ganglia. Alternatively or additionally, the electrode may be extended or repositioned so that an electrode pair is in close proximity or contact with the diaphragmatic muscle, as discussed above. Alternatively, the paddle electrode may include one or more pairs of electrodes and the pairs may be in close proximity with the posterior vagal nerve, the splanchnic nerve, diaphragmatic muscle, and/or the cealic ganglia so that energization of the electrodes indiscriminately modulates the nerves.

[0075] Figures 18A and 18B illustrate implanting a balloon electrode 1860, according to another embodiment of the present invention. The balloon electrode 1860 may be implanted in a manner similar to that illustrated in Figures 15A-D, discussed above, so that the balloon electrode may be substantially or wholly disposed in the GE space. The balloon electrode may be similar to the paddle electrode 1560 except that a balloon 1565 is disposed on a surface of the paddle opposite to the electrode surface of the paddle. The balloon may be made from one of the materials discussed above for the balloon 200 and inflated with one of the fluids discussed above for the balloon 200. The lead conduit 1855 may further include a catheter (not shown) for inflation of the balloon. The balloon may be bonded to the paddle surface, such as molding thereto or using an adhesive. Inflation of the balloon may improve contact with the anterior vagal nerve and/or diaphragmatic muscle and restrict the esophagus/cardiac orifice as discussed above in relation to the balloon 200, thereby providing a dual prong treatment for obesity.

[0076] Figures 19A and 19B illustrate the electrode assembly 1850 in deflated and inflated positions, respectively. The electrode assembly may be part of a neuromodulator, similar to the neuromodulator 1590. The neuromodulator may

include a generator (not shown) similar to the generator 1570. The generator may further include an electric pump to inflate the balloon and a reservoir to store inflation fluid. The generator may include a pressure sensor for monitoring a volume of the balloon. In this manner, the generator may inflate the balloon to a predetermined pressure and then a restricted diameter of the esophagus/cardiac orifice may be determined as discussed above. A new pressure may then be communicated wirelessly to the implanted generator and the generator may respond by inflating/deflating the balloon appropriately to optimize constriction of the esophagus. Alternatively, the generator may be worn by the patient externally and the generator may include an external fill port and a valve, thereby allowing an external pump or syringe (not shown) to be connected for inflating/deflating the balloon.

[0077] Figures 20A and 20B illustrate an alternative placement of the balloon electrode 1860, according to another embodiment of the present invention. Similar to the Figure 17 alternative, the balloon electrode may be placed in electrical communication with the anterior vagal and ganglia/splanchnic nerves to selectively modulate the nerves in addition to constricting the esophagus.

[0078] Figures 21A-H illustrate an alternative method for implanting the balloon electrode, according to another embodiment of the present invention. A guide wire may be inserted posteriorly between the vertebral column and the diaphragm and through the POL 20p. The insertion may be to the right of the vertebral column (shown) or to the left. A first dilator 2110 may then be slid over the guide wire to enlarge the opening. The guide wire may then be removed. A second dilator 2115 may then be slid over the first dilator to further enlarge the opening. The first dilator may then be removed. A third dilator 2120 may then be slid over the second dilator. The second dilator may then be removed. The balloon electrode assembly 1850 may then be inserted through the third dilator. The third dilator may then be removed. A distal end of the lead conduit may be pre-formed into an L-shape so that the balloon electrode is biased toward a position in the GE space 30 between the cardiac orifice/esophagus and the aorta. Alternatively, the balloon electrode assembly may be steerable. Once the balloon electrode assembly is in position, the balloon may be inflated, thereby restricting the esophagus/cardiac orifice and firmly pressing the electrodes into engagement with the nerves. The balloon electrode may be implanted vertically at either location, discussed above in relation to Figures 18 and 20.

Alternatively, the paddle electrode 1560 may be used instead of the balloon electrode 1860.

[0079] Figures 22A and 22B are views of a portion of the GI tract illustrating possible approaches for the posterior insertion of Figures 21A-H. The wire, dilators, and catheter assemblies may be inserted through the POL along a horizontal path proximate to the diaphragm and between the diaphragm and the stomach. Alternatively, the wire, dilators, and catheter assemblies may be inserted through the diaphragm and the POL along an inclined path.

[0080] Figures 23A-23F illustrate posterior implantation of a catheter electrode 2350, according to another embodiment of the present invention. A spinal needle 2305 may be inserted posteriorly into the diaphragm proximate to the vertebral column and through the POL. The catheter electrode may then be inserted through the spinal needle and into the GE space. As a tip 2360 of the catheter electrode 2350 exits the spinal needle, the tip may be steered toward a posterior portion (Figures 23C, 23E, and 23F) of the cardiac orifice/esophagus or toward an anterior portion of the cardiac orifice/esophagus (Figure 23D). As with the paddle/balloon electrodes, the catheter electrode may be implanted so that a first electrode pair is in close proximity or contact with the posterior vagal nerve and the second electrode pair is in close proximity or contact with the left splanchnic nerve 1520a, celiac ganglia 1520, and/or right splanchnic nerve 1520b. In this manner, the modulator controller may selectively modulate (i.e., stimulate or block) the anterior vagal nerve 1515b by energizing the first electrode pair, thereby creating/blocking a parasympathetic response or the celiac ganglia/splanchnic nerves by energizing the second electrode pair, thereby creating/blocking a sympathetic response, as desired to treat obesity. Alternatively, the catheter electrode may be implanted laterally or anteriorly. Alternatively, the catheter electrode may be placed in contact/close proximity with only the vagal nerve, the diaphragmatic muscle, or both.

[0081] Figure 24A illustrates the spinal needle 2305. Figure 24B illustrates the catheter electrode 2350. The catheter electrode 2350 may include an elongated lead conduit 2355 having proximal and distal ends, a tip 2360 at the distal end of the lead conduit 2355, and a control handle (not shown) at the proximal end of the lead conduit 2355. A suitable control handle is discussed and illustrated in U.S. Re. 34,502, which is herein incorporated by reference in its entirety.

[0082] The lead conduit 2355 may include an elongated tubular construction section having a single lumen. The lead conduit 2355 may be flexible, i.e., bendable, but substantially non-compressible along its length. The lead conduit 2355 may be made from a biocompatible material, such as a nylon tube surrounded by braided stainless steel with a polyurethane coating. The tip 2360 may include a short section of flexible tubing having a pair of nonoverlapping, e.g., side-by-side first and second lumens which are eccentric, i.e., are not coaxial with the tip 2360. The tubing may be made from a material more flexible than the lead conduit 2355, such as polyurethane.

[0083] One or more pairs 2361-2364 of electrodes may be disposed along a length of the tubing. The electrodes may be rings made from an electrically conductive and biocompatible material, such as a metal or alloy. An outer diameter of the electrodes may be about the same as the outer diameter of the tubing so that the electrodes form a smooth, continuous outer surface with the outer surface of the flexible tubing. Lead wires may extend from the control handle through the lumen of the lead conduit 2355 and into the second lumen of the tip 2360. Each lead wire may be attached to a respective electrode. A distal end of the flexible tubing may be rounded to serve as a guide nose. The proximal end of the tip 2360 may include an outer circumferential notch and the distal end of the lead conduit 2355 may include an inner circumferential notch. The notches may be sized to form a snug fit. The tip 2360 may then be bonded to the lead conduit, such as with an adhesive.

[0084] A puller wire may extend from the control handle through the lumen of the lead conduit 2655 and into the first lumen of the tip 2360. The puller wire may be made from a metal or alloy, such as stainless steel. The puller wire may extend into the first lumen of the tip 2360 to a position near the distal end of the tip and may be attached to the wall of the flexible tubing. The puller wire may be surrounded by a sheath for lubricity and to keep the puller wire generally coaxial with the lead conduit 2355. The sheath may be made from a polymer, such as PTFE. The sheath may be swaged in the first lumen to accommodate the smaller first lumen of the tip 2360.

[0085] The control handle may include a tubular housing having a piston chamber formed at the distal end of the housing and a connector chamber formed at the proximal end of the housing. A longitudinal passage and an offset passage may lead from the piston chamber to the connector chamber. The housing may be generally symmetrical about its longitudinal axis. A cylindrical piston may be slidably disposed

within and generally coaxial with the piston chamber. A seal, such as an o-ring may be disposed in an outer surface of the piston and engage an inner surface of the housing.

[0086] The piston may have a slot extending along an outer surface thereof. A fastener may extend through a wall of the housing and into the slot, thereby allowing longitudinal movement of the piston relative to the housing while keeping the piston coupled to the housing. The piston may have a longitudinal bore formed therethrough. The lead conduit 2355 may extend into the piston bore and may be bonded to the piston, such as by an adhesive. The distal end of the piston may extend beyond the distal end of the housing. An annular thumbrest may be attached to the distal end of the piston to facilitate longitudinal movement of the piston.

[0087] The puller wire may extend through the piston bore and may be attached to the housing by an anchor. The anchor may extend into a transverse hole in the portion of the housing between the connector chamber and piston chamber. The anchor may block the longitudinal passage, but not the offset passage. The anchor may be rotatable within the hole, but may fit snugly so that it does not rotate freely. The anchor may include a transversely extending hole which may be rotated into alignment with the longitudinal passage. The puller wire may pass through the longitudinal passage and anchor hole and wedged between the anchor and the wall of the housing. Tension on the puller wire may be adjusted by rotation of the anchor.

[0088] The lead wires may extend from the lead conduit 2355 proximally through the piston bore, the piston chamber, the offset passage between the piston and connector chambers, and into the connector chamber. A sheath may surround and protect the lead wires in the piston chamber, offset passage and connector chamber. The lead wires and sheath may be bowed or looped in one of the chambers to provide slack. In the connector chamber, the lead wires may be connected to a rotary connector. The rotary connector may include a cylindrical male plug extending proximally from the control handle housing coaxially with the housing. The plug may have a series of electrical contacts or terminals along its length, each of which is electrically connected to a separate lead, and, therefore, a separate lead wire, within the connector chamber. The plug may be connected with the modulator generator (discussed above). An annular flange may secure the rotary connector to the housing and may seal the proximal end of the connector chamber. A vent may lead from the

connector chamber. The vent may be through the housing wall, flange or through the plug of the rotary connector.

[0089] In use, the tip 2360 may be curved or bent to steer the tip by gripping the control handle housing and moving the piston distally out of the piston chamber by pushing outwardly on the thumbrest. This action may cause movement of the puller wire relative to the lead conduit 2355 and tip 2360, effectively pulling the tip 2360 proximally toward the control handle. Because the puller wire may be offset from the axis of the tip 2360, the tip may bend in the direction of the offset, to accommodate the force exerted on it.

[0090] Figures 25A and 25B illustrate posterior endoscopic implantation of the catheter electrode 2350, according to another embodiment of the present invention. The opening through the POL may be formed using the guide wire and dilators, as discussed above. A tube 2555 of the endoscope may then be inserted through the third dilator 2120. The tube may conduct an image of the GE space to the surgeon to facilitate implantation of the catheter electrode.

[0091] Figures 26A and 26B illustrate a distal end of the endoscope tube 2555. The endoscope may include a head 2550 having a bore 2550b for receiving an optical cable and a side port 2550p for receiving the catheter electrode. The endoscope may further include a light source. The endoscope may further include the tube 2555 having dual lumens (i.e., concentric or eccentric) connected to the head 2550. An optical lumen may conduct the optics and a working lumen may conduct the catheter electrode. The tube may be rigid or flexible and the endoscope may be analog or digital. If rigid, the optical lumen may house an optical fiber bundle for conducting light from the light source to illuminate the object and a lens system for conducting the object image from the lens 2560 to an eyepiece or video processor. If the tube is flexible, then a second fiber bundle may replace the lens system (analog) or an image sensor (i.e., CCD or CMOS) may capture and convert the image to an electrical signal and an AFE may digitize the signal and send the signal to the video processor via an electrical cable.

[0092] The endoscope tube 2555 may further include a nose 2558 to protect the lens 2560 and guide the tube 2555. The nose 2558 may be made from a transparent and biocompatible material, such as glass, laminated glass, or a polymer, such as

polycarbonate or acrylic. The nose 2558 may be quarter-ellipsoid or quarter-spherical in shape. The nose 2558 may be bonded to the distal end of the tube, such as with an adhesive.

[0093] Figures 27A and 27B illustrate posterior endoscopic implantation of the balloon electrode 1860, according to another embodiment of the present invention. The opening through the POL may be formed using the guide wire and dilators, as discussed above. The endoscope tube 2555 may then be inserted through the third dilator 2120. Once implanted into the GE space, the balloon may be inflated to restrict the cardiac orifice/esophagus and ensure firm engagement of the electrodes with the target nerve(s).

[0094] Alternatively, the balloon, paddle, or catheter electrode may be implanted anteriorly using the endoscope and one or more trocars or laterally using the endoscope.

WHAT IS CLAIMED IS:

1. A method for treating a patient, comprising:
introducing an electrode at least partially into a gastroesophageal (GE) space formed between an inner wall of a phrenoesophageal ligament (POL) and outer walls of the esophagus and cardiac orifice; and
modulating tissue using the electrode.
2. The method of claim 1, wherein the electrode is introduced substantially or wholly within the GE space.
3. The method of claim 1, further comprising securing the electrode to the POL.
4. The method of claim 3, wherein the electrode is secured to an interior portion of the POL.
5. The method of claim 3, wherein the electrode is secured to an exterior portion of the POL.
6. The method of claim 1, further comprising promoting a feeling of satiety in the patient during or after modulation.
7. The method of claim 1, wherein the tissue comprises a portion of the diaphragm.
8. The method of claim 7, wherein the tissue further comprises a portion of a nerve that innervates the diaphragm portion.
9. The method of claim 1, wherein the tissue comprises a portion of a vagal nerve.
10. The method of claim 1, wherein the tissue comprises a portion of a splanchnic nerve.

11. The method of claim 1, wherein the tissue comprises a portion of a celiac ganglion.
12. The method of any of claims 7, 9, and 11 further comprising modulating a ventral aspect of the tissue.
13. The method of claim 1 wherein modulating tissue using the electrode provides a signal from the electrode towards an aspect of a neural structure that faces towards a portion of the POL used to support the electrode.
14. The method of claim 1, further comprising advancing the electrode within the GE space into a position adjacent a ventral aspect of a portion of the tissue.
15. The method of claim 14, further comprising passing a least a portion of the electrode out of the GE space towards a portion of the tissue.
16. The method of claim 15, further comprising passing at least a portion of the electrode in a dorsal direction out of the GE space towards a portion of the tissue.
17. The method of claim 14, further comprising passing at least a portion of the electrode out of the GE space towards a portion of the tissue without passing the electrode beyond a coronal plane passing through a portion of the aorta.
18. The method of claim 17, wherein the portion of the aorta comprises a ventral aspect of the aorta.
19. The method of claim 17, wherein the portion of the aorta comprises a dorsal aspect of the aorta.
20. The method of claim 1, further comprising forming an opening in the POL and thereafter introducing the electrode into the GE space through the opening.
21. The method of claim 20, further comprising laterally inserting a surgical instrument into the patient before forming the opening.

22. The method of claim 20, further comprising anteriorly inserting a surgical instrument into the patient before forming the opening.
23. The method of claim 22, wherein the electrode is introduced endoscopically through a trocar.
24. The method of claim 20, further comprising posteriorly inserting a surgical instrument into the patient and thereafter forming the opening in the GE space using the surgical instrument.
25. The method of claim 24, wherein the instrument comprises a guide wire and one or more dilators.
26. The method of claim 1, wherein the electrode is mounted on a paddle.
27. The method of claim 1, wherein the electrode is mounted on a steerable catheter.
28. The method of claim 1, wherein the electrode is introduced using an endoscope.
29. A method for treating a patient, comprising:
approaching a portion of the phrenoesophageal ligament (POL) with an instrument;
advancing an electrode along the instrument to a position adjacent the POL;
applying an electrical signal to tissue adjacent to the POL using the electrode.
30. The method of claim 29, further comprising supporting at least a portion of the electrode with the POL.
31. The method of claim 30, wherein the at least a portion of the electrode is adjacent an outer layer of the POL.

32. The method of claim 30, wherein the at least a portion of the electrode is adjacent an inner layer of the POL.
33. The method of claim 29, the approaching step further comprising advancing the instrument dorsally towards the POL.
34. The method of claim 29, the approaching step further comprising advancing the instrument ventrally towards the POL.
35. The method of claim 29, the approaching step further comprising advancing the instrument laterally towards the POL.
36. The method of claim 29, wherein the POL portion is superior to the diaphragm.
37. The method of claim 36, wherein the POL portion is lateral of a spinal midline.
38. The method of claim 29, wherein the POL portion is inferior to the diaphragm.
39. The method of claim 38, wherein the POL portion is lateral of a spinal midline.
40. The method of claim 29, wherein applying a signal comprises applying a signal that modulates neural activity.
41. The method of claim 29, wherein applying a signal comprises applying a signal that inhibits neural activity.
42. The method of claim 29, wherein applying a signal comprises applying a signal that stimulates neural activity.
43. The method of claim 29, wherein the tissue adjacent to the POL comprises a neural tissue.
44. The method of claim 43, wherein the neural tissue comprises at least one of:

a portion of a vagal nerve; a portion of splanchnic nerve; a portion of a celiac ganglion or a portion of a nerve that innervates a portion of a diaphragm.

45. The method of claim 29, wherein the tissue adjacent to the POL comprises muscle tissue.

46. The method of claim 45, wherein the muscle tissue comprises a diaphragm.

47. The method of claim 45, wherein the muscle tissue comprises a stomach.

48. A method for treating a patient, comprising:
forming an opening in the phrenoesophageal ligament (POL);
introducing a balloon through the opening and into a gastroesophageal (GE) space formed between an inner wall of the POL and outer walls of the esophagus and cardiac orifice; and
inflating the balloon to provide therapy to the patient.

49. The method of claim 48, wherein the therapy comprises at least partially restricting the esophagus and/or cardiac orifice in proximity to the balloon.

50. The method of claim 48, wherein the therapy comprises: urging an electrode disposed at least partially within the GE space into closer proximity to a targeted neural structure and thereafter delivering an electrical signal to the targeted neural structure with the electrode.

51. The method of claim 48, wherein at least a portion of the balloon is disposed between diaphragm and the cardiac orifice and/or esophagus.

52. The method of claim 51, wherein inflating the balloon distends at least a portion of the diaphragm.

53. The method of claim 51, wherein inflating the balloon distends at least a portion of the cardiac orifice.

54. The method of claim 51, wherein inflating the balloon distends at least a portion of the esophagus.
55. The method of claim 48, wherein after inflating the balloon, at least a portion of the balloon is generally shaped like an ellipsoid, an egg, a cylinder, or a polyhedron.
56. The method of claim 48, wherein the opening is formed by:
advancing a surgical instrument towards the POL; and
engaging the POL with the distal end of the instrument.
57. The method of claim 56, wherein the POL is engaged by grasping the POL with the instrument.
58. The method of claim 57, wherein the POL is further engaged by separating the POL from tissue within the GE space.
59. The method of claim 58, wherein the POL separated before forming the opening.
60. The method of claim 56, wherein the POL is engaged by applying a vacuum to the POL using the instrument.
61. The method of claim 56, wherein the POL is engaged by advancing tines from the distal end of the surgical instrument and piercing the POL.
62. The method of claim 48, further comprising fastening the balloon to the POL.
63. The method of claim 48, wherein:
the balloon comprises a first wall having a first stiffness, a second wall having a second stiffness, and a partition,
the first wall and the partition enclose a first chamber,
the second wall and the partition enclose a second chamber, and
the second stiffness is greater than the first stiffness.

64. The method of claim 63, wherein:
the first wall exerts pressure on the wall of the cardiac orifice and/or esophagus, and
the second wall is supported by the diaphragm.
65. The method of claim 64, wherein:
the first chamber is in fluid communication with a first valve,
the second chamber is in fluid communication with a second valve, and
the valves provide for independent inflation of the chambers.
66. The method of claim 48, wherein:
the balloon is inflated to a first size, and
the method further comprises inflating the balloon to a second larger size after a period of time sufficient for the patient to become accustomed to the balloon.
67. The method of claim 48, wherein the balloon is inflated until a balloon pressure reaches a predetermined pressure.
68. The method of claim 48, further comprising:
inserting a pressure sensor into the esophagus and/or cardiac orifice to a position adjacent the balloon; and
monitoring pressure of the balloon using the pressure sensor while inflating the balloon.
69. The method of claim 68, wherein inflating the balloon is performed until a predetermined pressure is measured by the pressure sensor that corresponds to a desired degree of luminal restriction.
70. The method of claim 48, wherein the therapy comprises inflating the balloon to provide a degree of luminal restriction.
71. The method of claim 70, wherein the degree of luminal restriction is provided in at least a portion of the esophagus.

72. The method of claim 70, wherein the degree of luminal restriction is provided in at least a portion of the stomach.
73. The method of claim 48, wherein:
the balloon is inflated to a first size, and
the method further comprises:
 injecting a contrasting agent into the esophagus and cardiac orifice;
 imaging at least a portion of the esophagus and/or the cardiac orifice;
determining a degree of the restriction of the esophagus and/or cardiac orifice using the image.
74. The method of claim 48, wherein the balloon further exerts pressure on the stomach fundus.
75. The method of claim 48, further comprising:
inserting a trocar into a thorax or abdomen of the patient; and
inserting a working catheter into the trocar,
wherein:
 the working catheter comprises the balloon connected to a balloon catheter,
and
 the balloon is inflated by injecting fluid into the balloon catheter.
76. The method of claim 75, wherein the working catheter further comprises an endoscope.
77. The method of claim 48, wherein the esophagus and/or the cardiac orifice lumen is restricted to a first diameter, thereby restricting a rate of food intake by the patient.
78. The method of claim 48, wherein the esophagus and/or the cardiac orifice lumen is restricted to a first diameter, thereby facilitating esophageal closure.
79. The method of claim 48, wherein the lumen is restricted to a first diameter, thereby inhibiting or restricting reflux of stomach contents into the esophagus.

80. The method of claim 48, further comprising modulating tissue using an electrode attached to the balloon.
81. The method of claim 80, wherein the tissue comprises diaphragmatic muscle.
82. The method of claim 80, wherein the tissue comprises a vagal nerve.
83. The method of claim 82, wherein the tissue further comprises a splanchnic nerve and/or a celiac ganglion.
84. The method of claim 80, wherein at least two pairs of electrodes are attached to the balloon and inflating the member presses a first pair against a vagal nerve and a second pair of the electrodes against a splanchnic nerve and/or a celiac ganglion.
85. The method of claim 48, further comprising: performing the inflating step until an electrode moves into closer proximity to a portion of a vagal nerve; a portion of a splanchnic nerve; a portion of a celiac ganglion or a portion of a nerve that innervates a portion of a diaphragm.
86. The method of claim 85, wherein the portion of the vagal nerve comprises a ventral aspect of the vagal nerve; the portion of the splanchnic nerve comprises a ventral aspect of the splanchnic nerve; or the portion of the celiac ganglion comprises a ventral aspect of the celiac ganglion.
87. A catheter assembly for insertion into a patient, comprising:
a working catheter;
a balloon catheter disposed in the working catheter; and
a balloon connected to the balloon catheter, inflatable by injection of fluid through the balloon catheter, and comprising a first wall having a first stiffness, a second wall having a second stiffness, and a partition,
wherein the first wall and the partition enclose a first chamber and the second wall and the partition enclose a second chamber.

88. The catheter assembly of claim 87, wherein at least a portion of the inflated shape of the balloon is an ellipsoid, an egg, a cylinder, or a polyhedron.
89. The catheter assembly of claim 87, wherein the second stiffness is greater than the first stiffness.
90. The catheter assembly of claim 41, wherein the second stiffness is substantially greater than the first stiffness.
91. The catheter assembly of claim 87, wherein the balloon catheter comprises a first lumen in fluid communication with the first chamber and a second lumen in fluid communication with the second chamber.
92. The catheter assembly of claim 87, further comprising:
a first valve is in fluid communication with the first chamber; and
a second valve is in fluid communication with the second chamber,
wherein operation of the valves provides independent fluid communication with the chambers.
93. The catheter assembly of claim 87, wherein the balloon is made from or coated with a biocompatible material.
94. The catheter assembly of claim 87,
further comprising a wire preformed into a hook,
wherein the wire is operable between:
a first position where the wire is elastically restrained inside the working catheter, and
a second position where the wire returns to the preformed hook as the wire is extended from the working catheter.
95. The catheter assembly of claim 46, further comprising an inner catheter disposed between the hook and the balloon catheter.

96. The catheter assembly of claim 87, further comprising an electrode attached to an outer surface of the balloon.
97. The catheter assembly of claim 87, further comprising:
an adapter connecting the balloon catheter and the balloon; and
a lug extending from an outer surface of the adapter.
98. A device for providing therapy to a patient, comprising:
an inflatable structure adapted and configured for positioning at least partially within a gastroesophageal (GE) space formed between an inner wall of a phrenoesophageal ligament (POL) and outer walls of the esophagus and cardiac orifice; and
an electrode structure adapted and configured for positioning at least partially within the GE space.
99. The device of claim 98, wherein when the inflatable structure is inflated at least a portion of the inflatable structure is shaped like an ellipsoid, an ovoid, a cylinder, a polyhedron or a portion of a curve.
100. The device of claim 98, wherein the electrode structure comprises flexible base that is sufficiently flexible to follow at least a portion of the interior shape of the GE space.
101. The device of claim 98, wherein at least a portion of the electrode structure is attached to the inflatable structure.
102. The device of claim 98, wherein the inflatable structure has a length selected to be less than the perimeter of the esophageal wall within the GE space.
103. The device of claim 98, wherein the inflatable structure has a length selected such that in use within the GE space, the inflatable structure circumscribes less than half the perimeter of the esophageal wall within the gastroesophageal (GE) space.

104. The device of claim 98, wherein the electrode structure has a length selected to be less than the perimeter of the esophageal wall within the GE space.

105. The device of claim 98, wherein the electrode structure has a length selected such that in use within the GE space, the electrode structure circumscribes less than half the perimeter of the esophageal wall within the GE space.

106. The device of claim 98, wherein the respective sizes of the electrode structure and the inflatable structure are selected such that both structures may be within the GE space without contacting one another.

107. The device of claim 98, wherein the electrode structure has a length selected such that in use within the GE space, the electrode structure circumscribes a first portion of the perimeter of the esophageal wall within the GE space and the inflatable structure has a length selected such that in use within the GE space the inflatable structure circumscribes a second portion of the perimeter of the esophageal wall within the GE space without overlapping with the first portion.

108. A method of treating a patient, comprising:
 positioning an electrode at or near a portion of the phrenoesophageal ligament (POL);
 advancing the electrode towards a neural target in proximity to the POL; and
 applying an electrical signal to the neural target using the electrode.

109. The method of claim 108, wherein advancing the electrode comprises advancing the electrode towards a ventral aspect of the neural target.

110. The method of claim 108, wherein advancing the electrode comprises advancing the electrode towards the neural target without passing through a coronal plane passing through a portion of the aorta.

111. The method of claim 110, wherein the coronal plane passing through a portion of the aorta passes through a ventral aspect of the aorta.

112. The method of claim 110, wherein the coronal plane passing through a portion of the aorta passes through a dorsal aspect of the aorta.

113. The method of claim 108, wherein the neural target comprises at least a portion of a vagal nerve, a splanchnic nerve, a celiac ganglion or a nerve that innervates a portion of a diaphragm.

114. The method of claim 108, wherein after positioning the electrode at or near a portion of the POL, at least a portion of the electrode is positioned at least partially within a gastroesophageal (GE) space formed between an inner wall of the POL and an outer wall of the esophagus and an outer wall of the stomach.

115. The method of claim 108, wherein advancing the electrode comprises advancing the electrode towards the neural target without passing through a coronal plane positioned at a ventral aspect of a vertebral body adjacent the POL.

116. The method of claim 108, wherein advancing the electrode towards a neural target in proximity to the POL further comprises: advancing the electrode in a lateral direction away from a portion of the POL.

117. The method of claim 108, wherein advancing the electrode towards a neural target in proximity to the POL further comprises: advancing the electrode in a dorsal direction away from a portion of the POL.

118. The method of claim 108, wherein advancing the electrode towards a neural target in proximity to the POL further comprises: advancing the electrode in a cephalad direction away from a portion of the POL.

119. The method of claim 108, wherein advancing the electrode towards a neural target in proximity to the POL further comprises: advancing the electrode in a caudal direction away from a portion of the POL.

FIG. 2

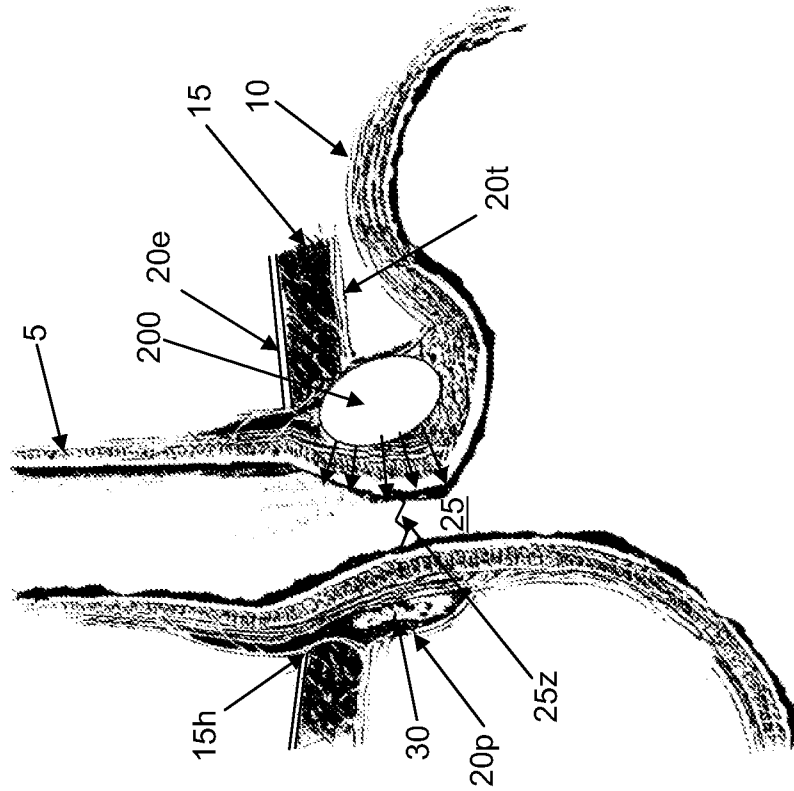
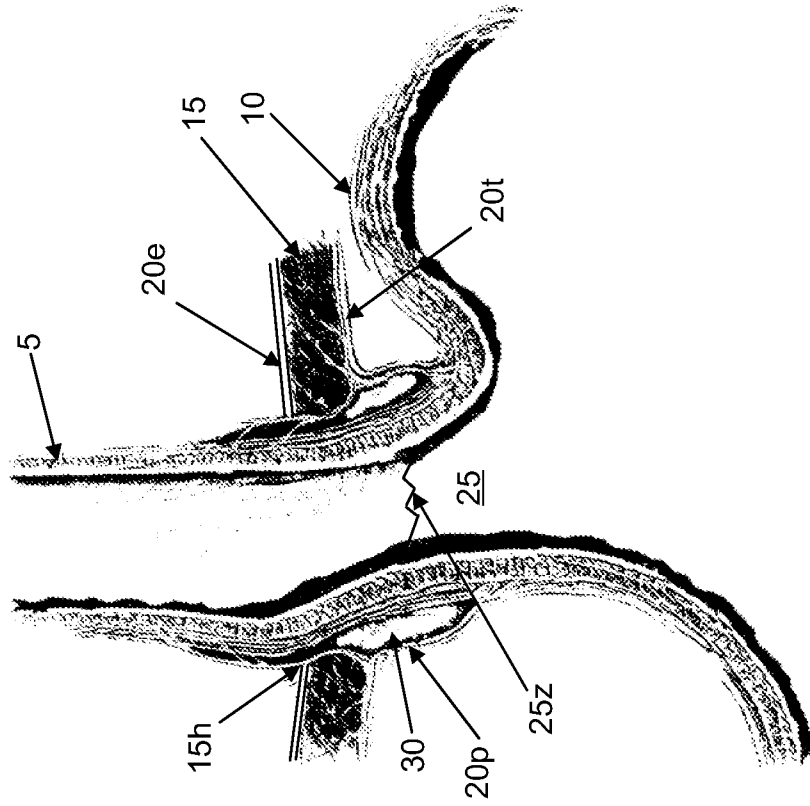

FIG. 1
(PRIOR ART)



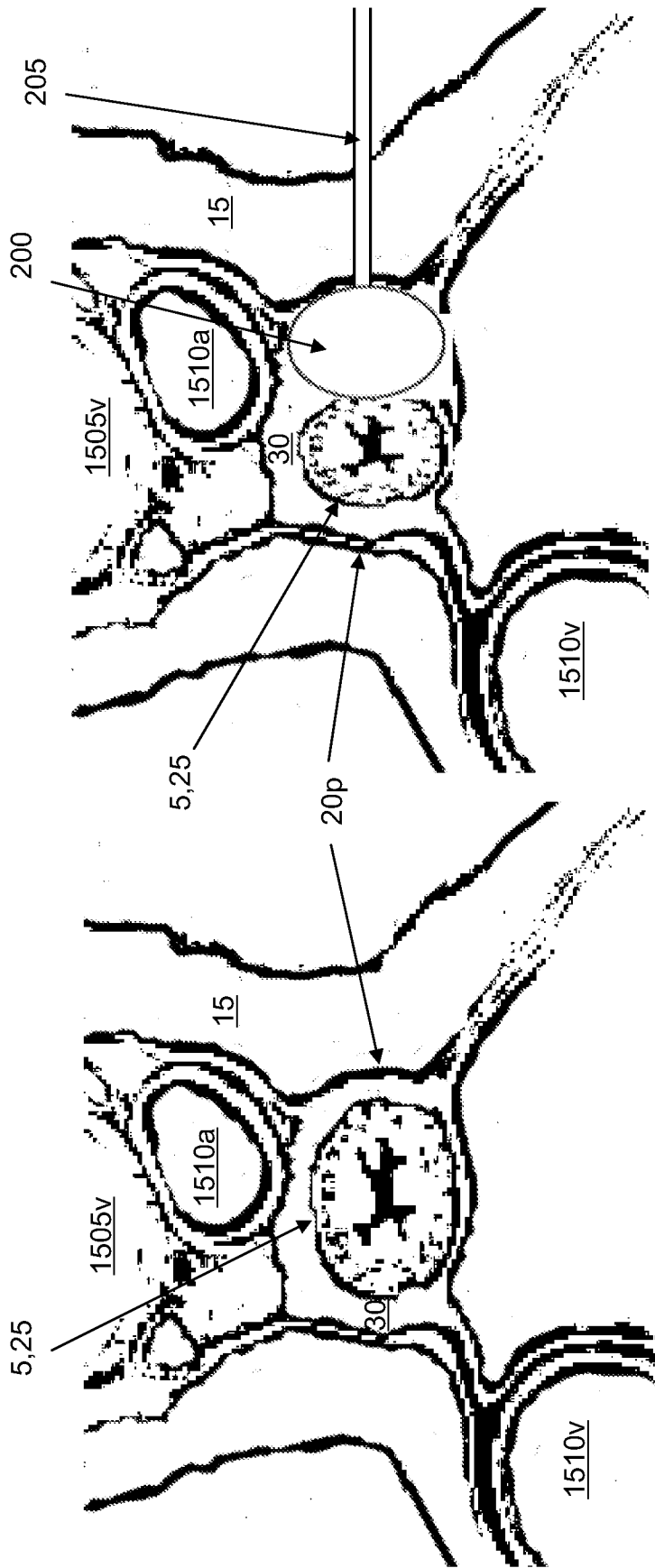

FIG. 1A
(PRIOR ART)

FIG. 2A

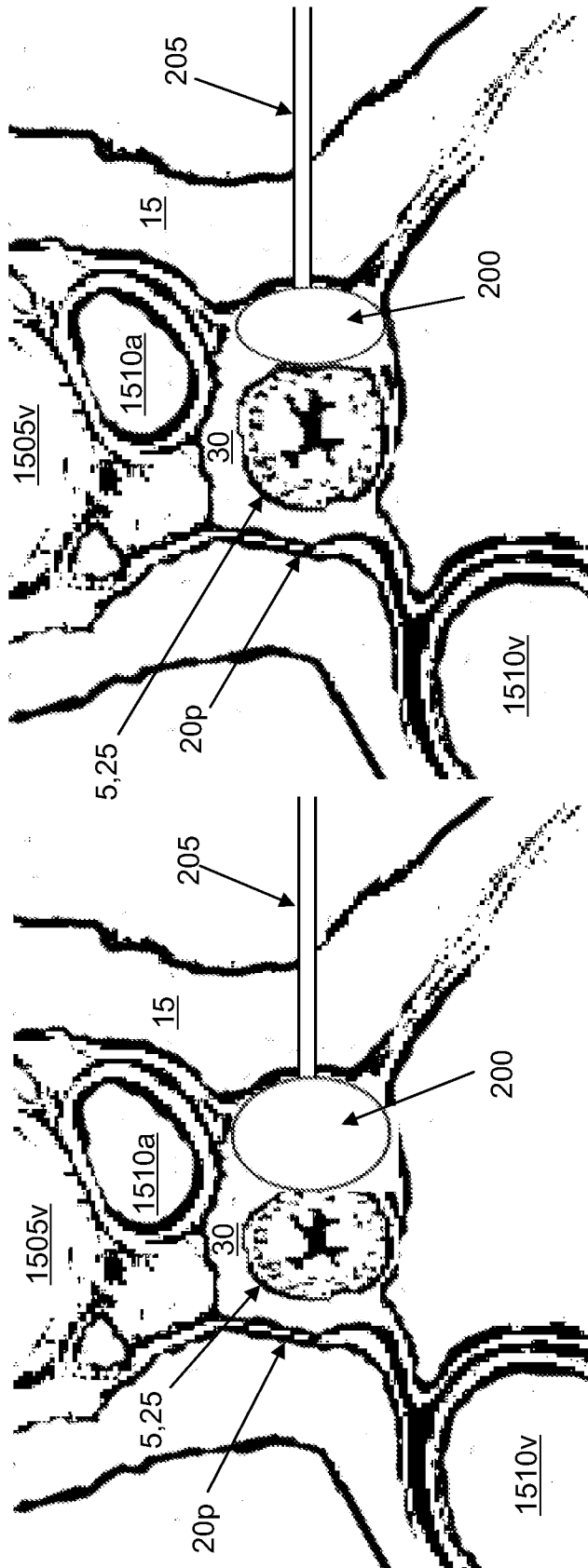

FIG. 3A

FIG. 3B

FIG. 4B

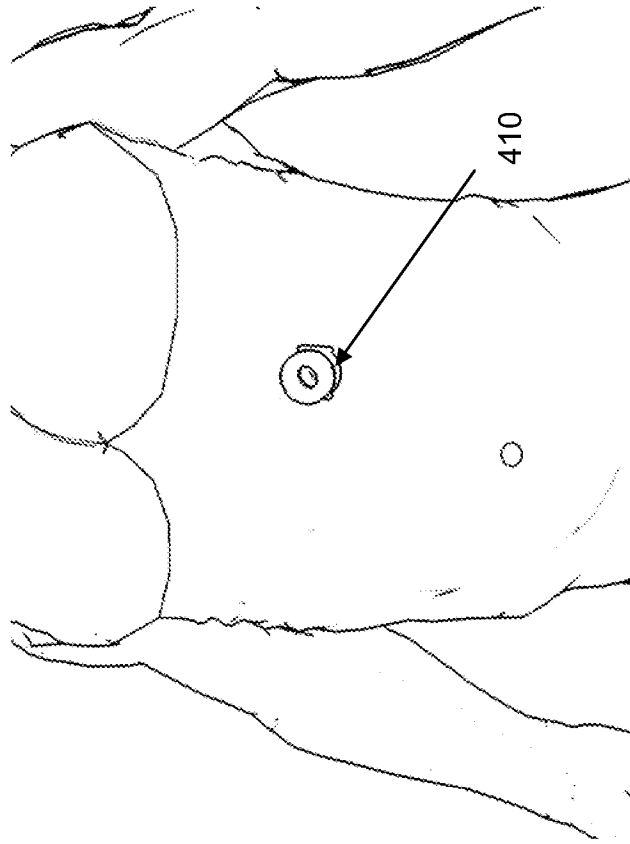
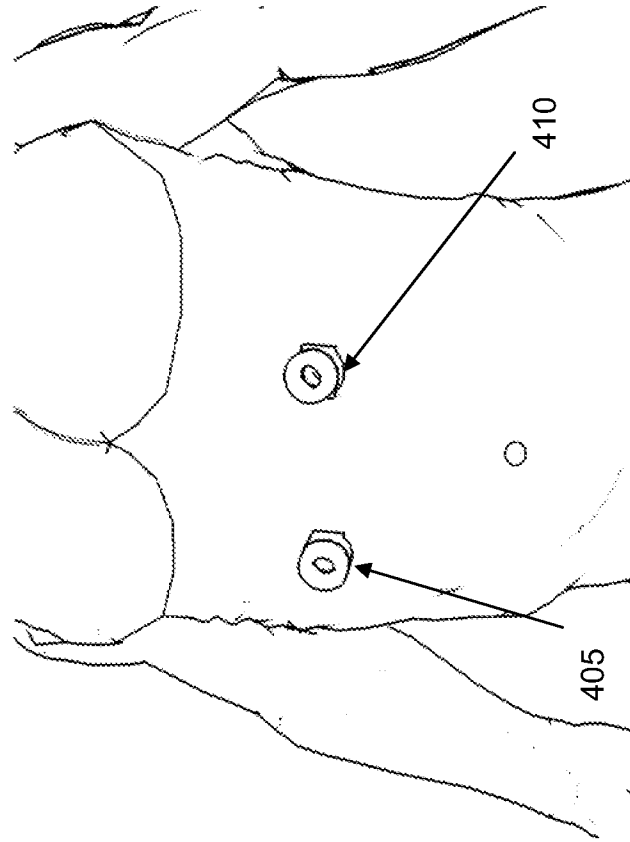

FIG. 4A



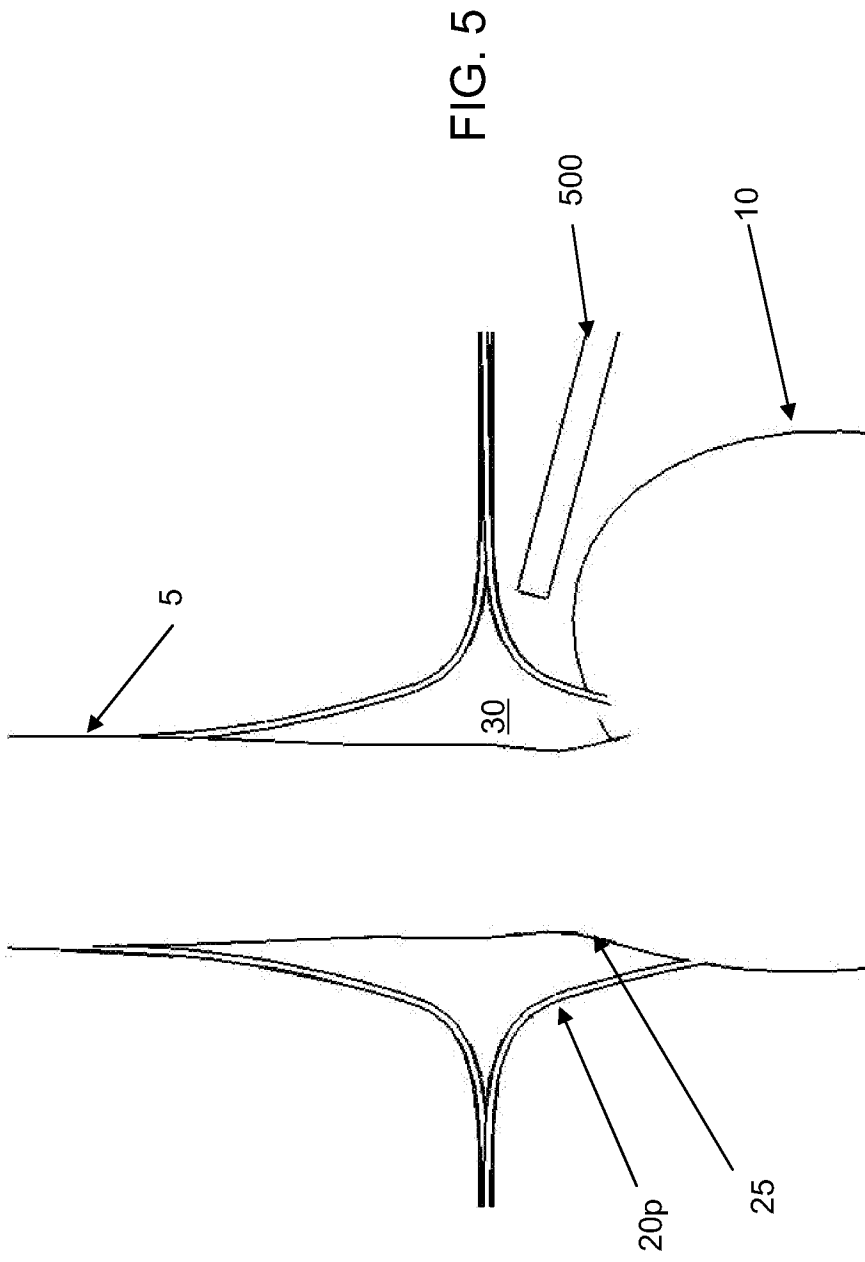

FIG. 6B

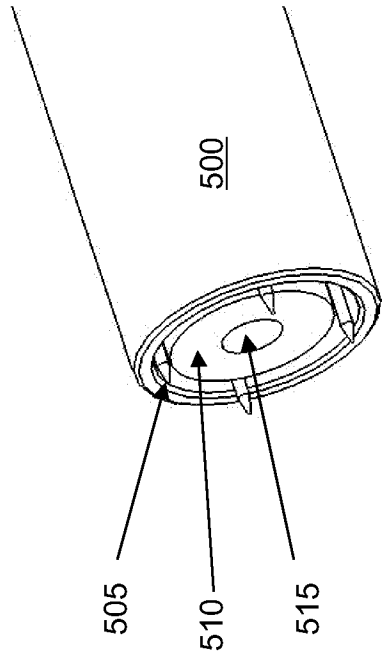

FIG. 6C

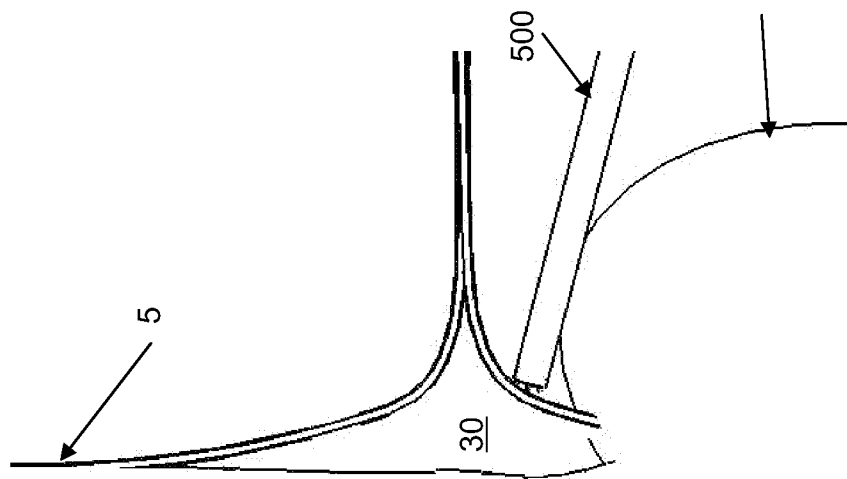
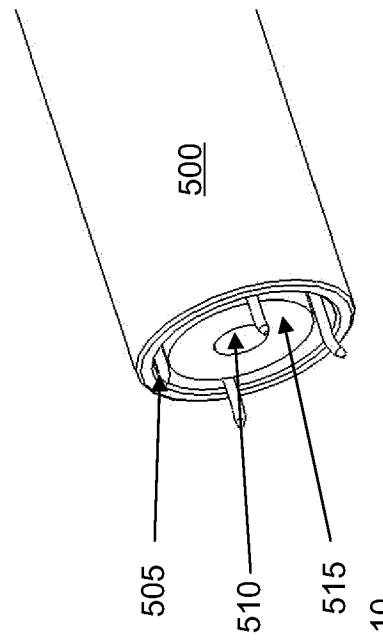

FIG. 6A

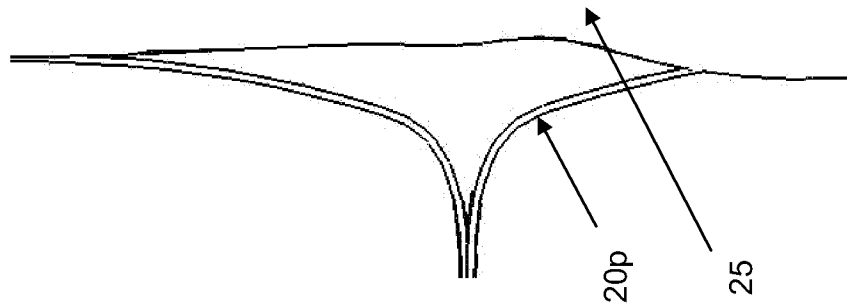

FIG. 7B

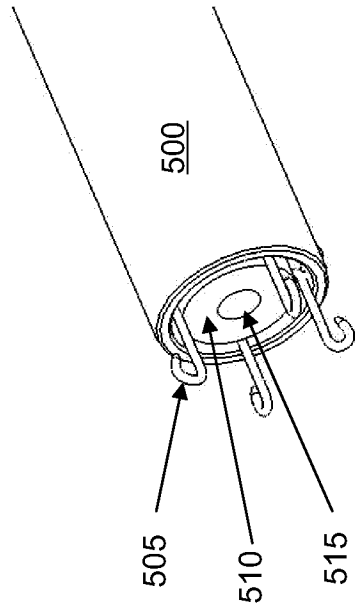

FIG. 7C

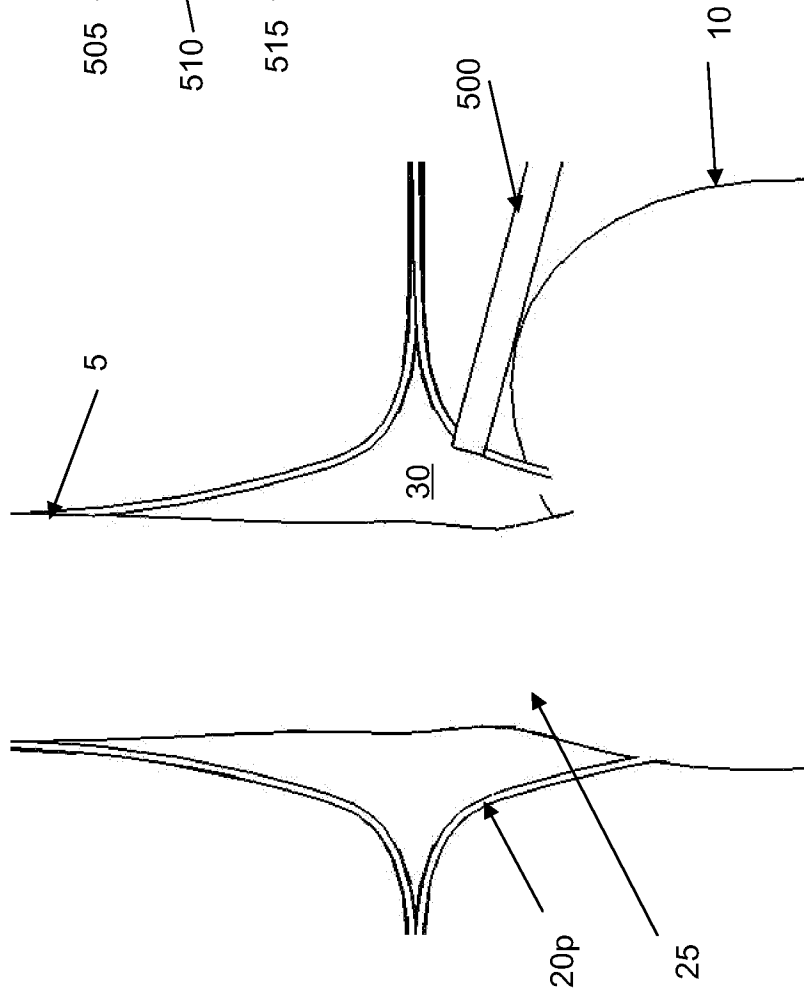
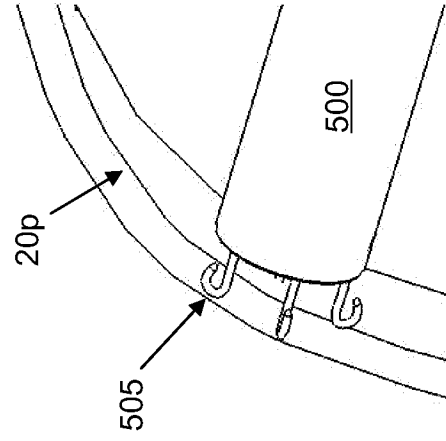

FIG. 7A

FIG. 8B

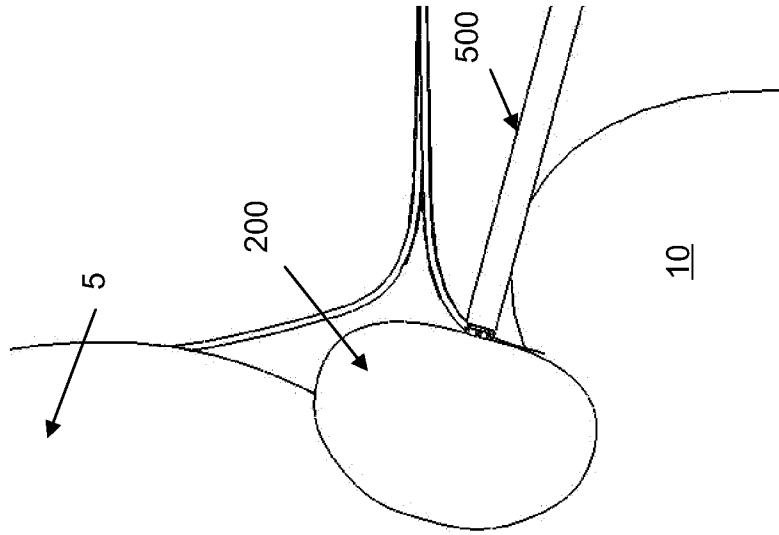

FIG. 8A

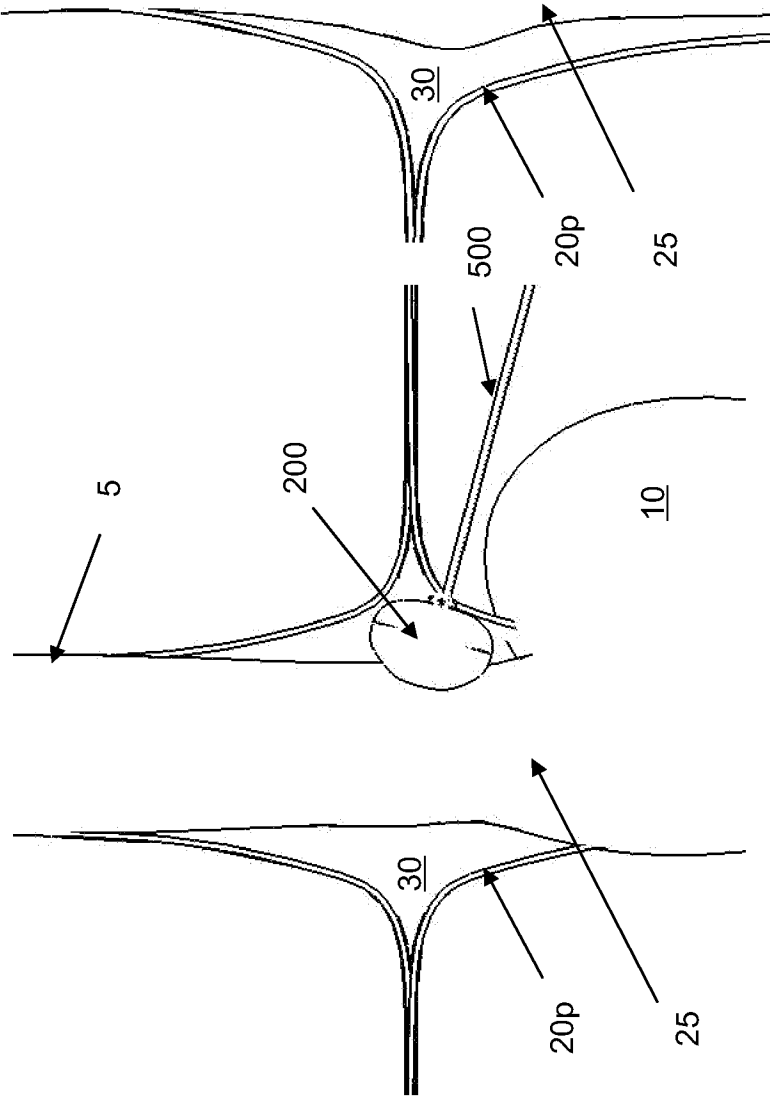

FIG. 9D

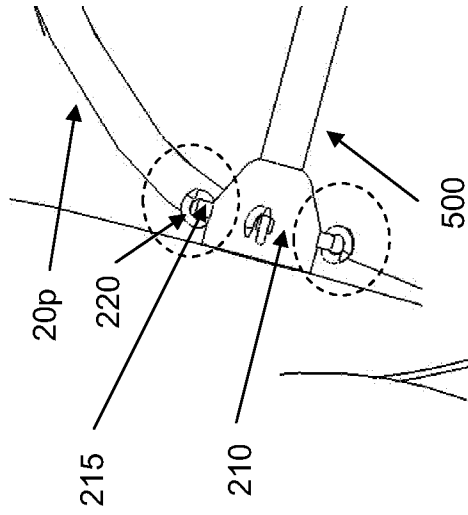

FIG. 9B

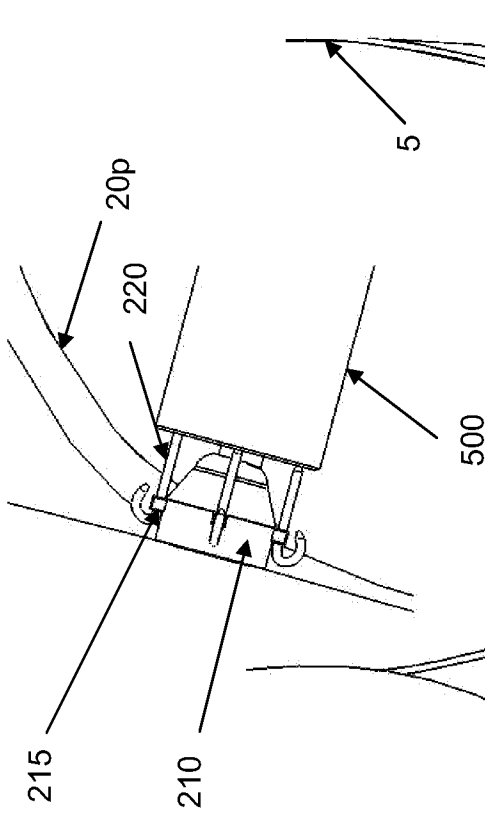

FIG. 9C

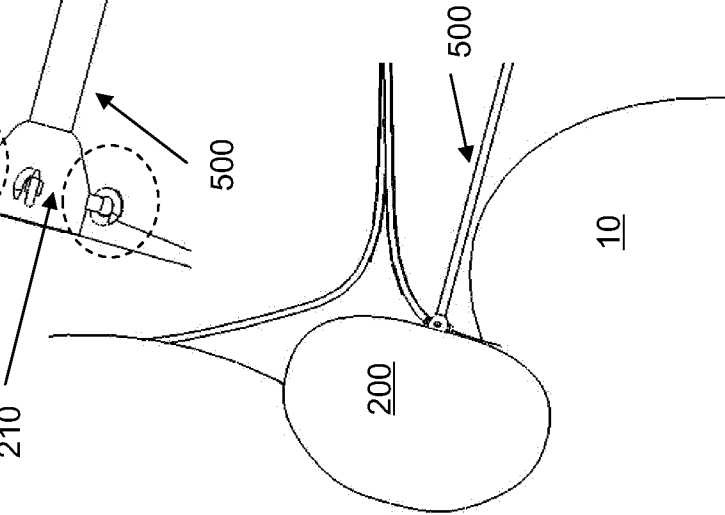

FIG. 9A

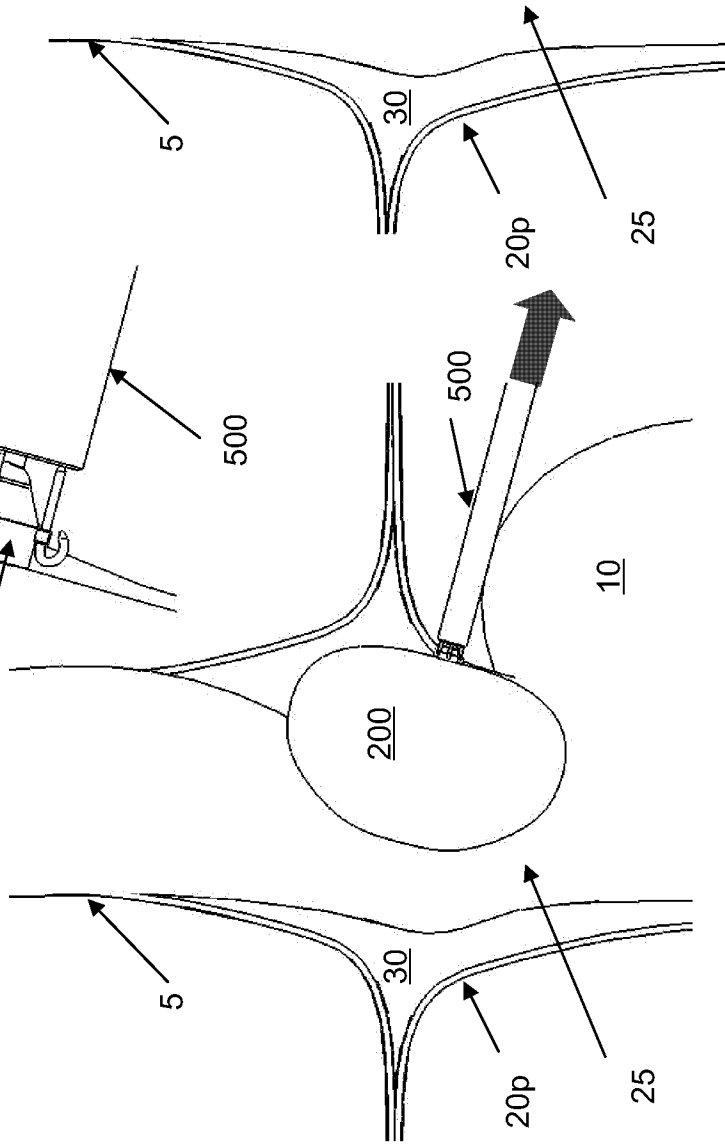

FIG. 10B

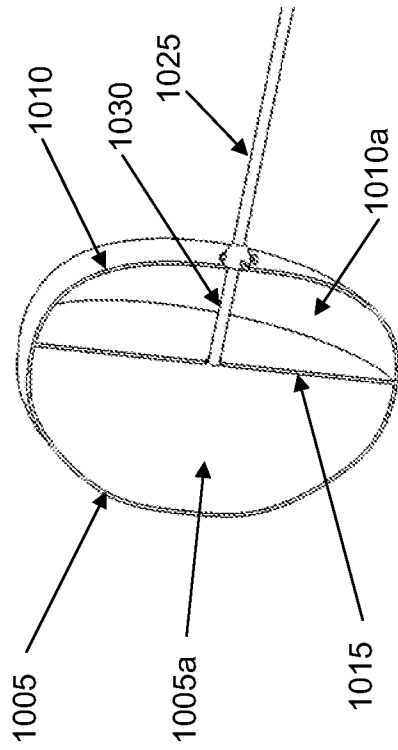

FIG. 10C

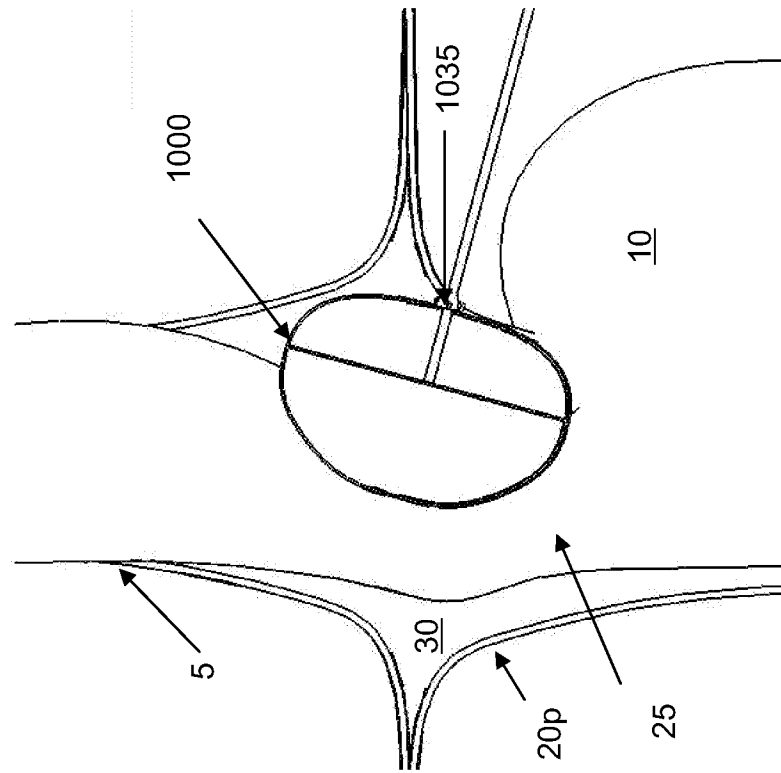
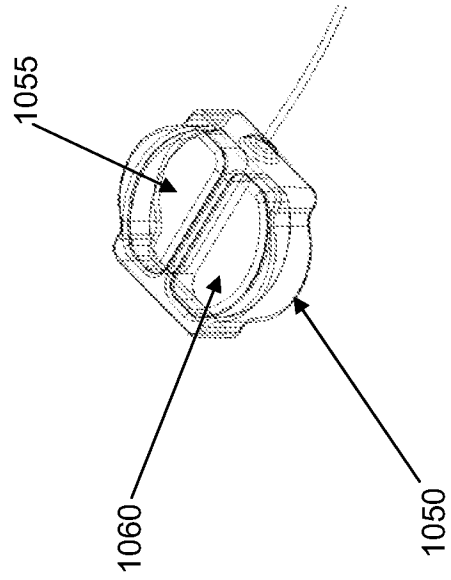

FIG. 10A

FIG. 11B

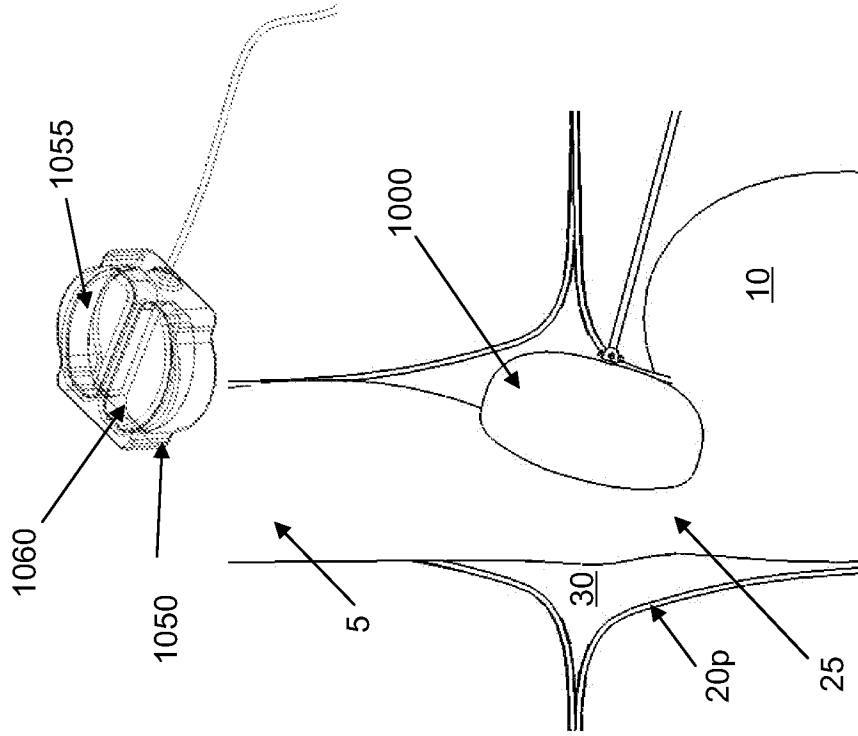

FIG. 11C

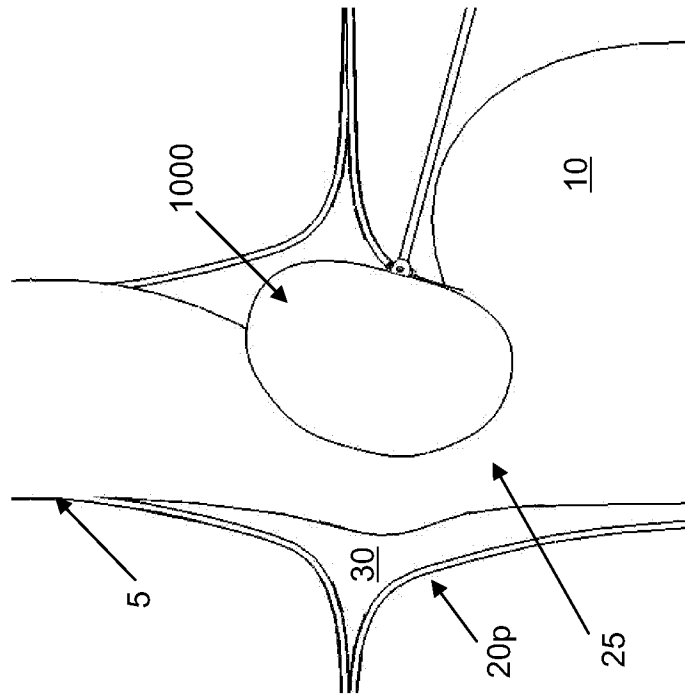

FIG. 11A

FIG. 12B

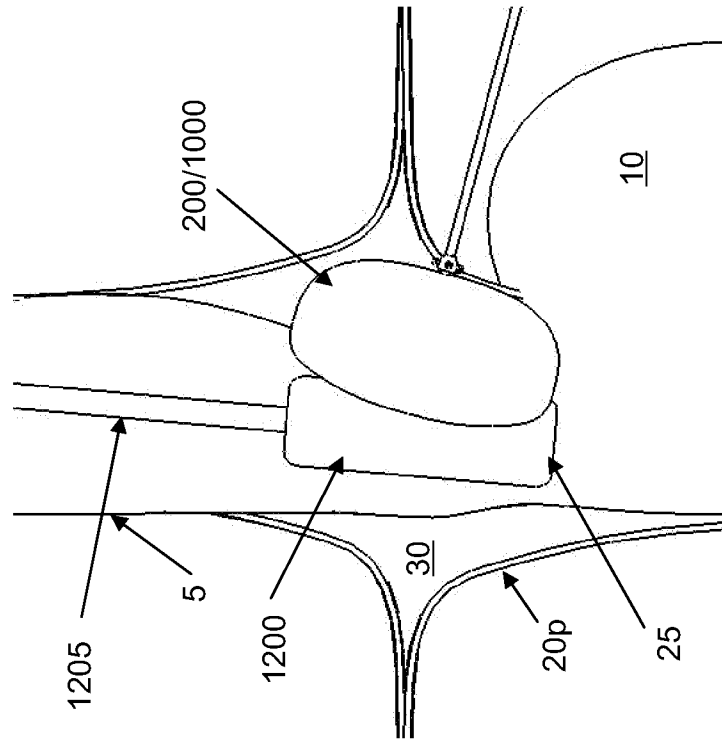

FIG. 12A

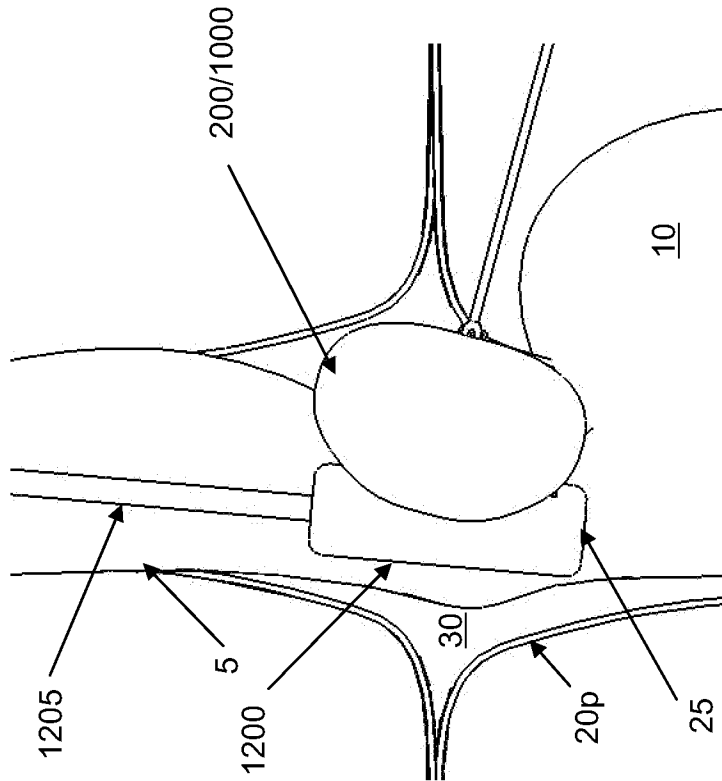

FIG. 13B

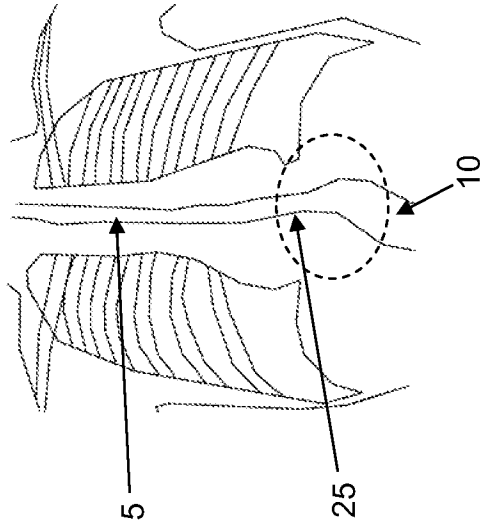

FIG. 13D

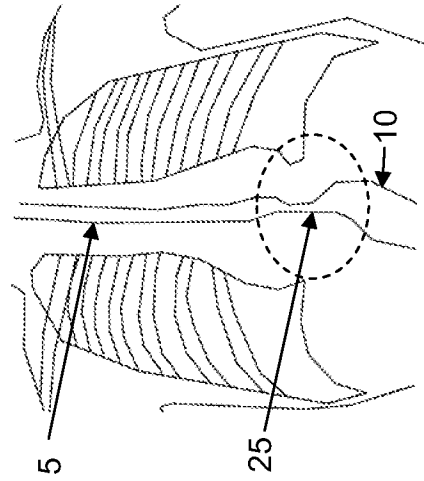

FIG. 13A

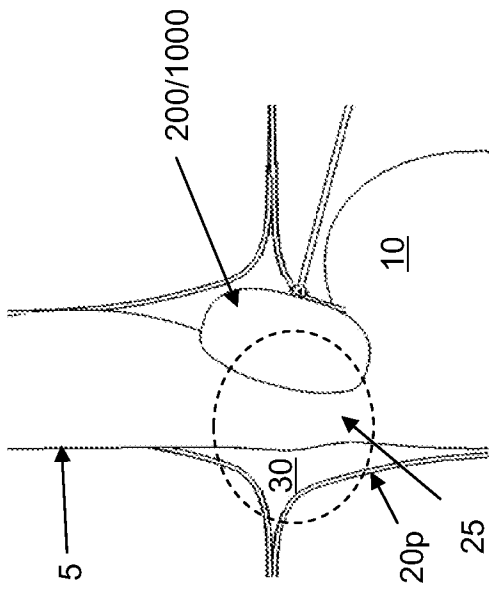
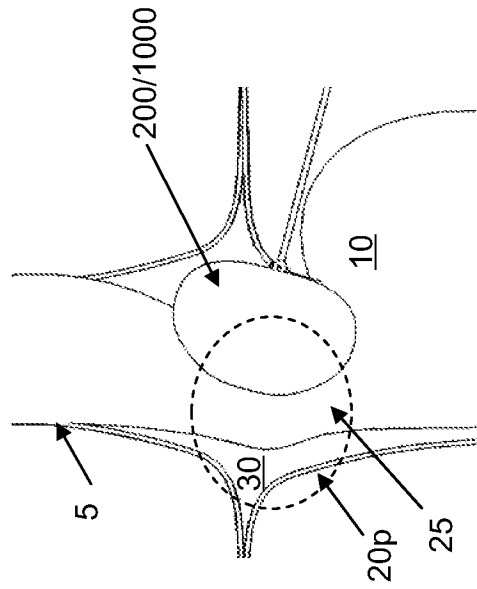

FIG. 13C



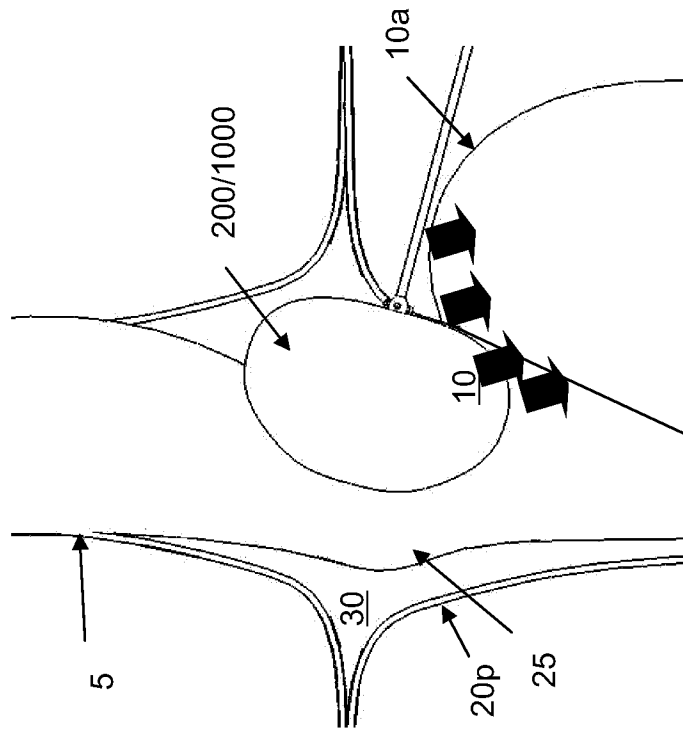

FIG. 14B

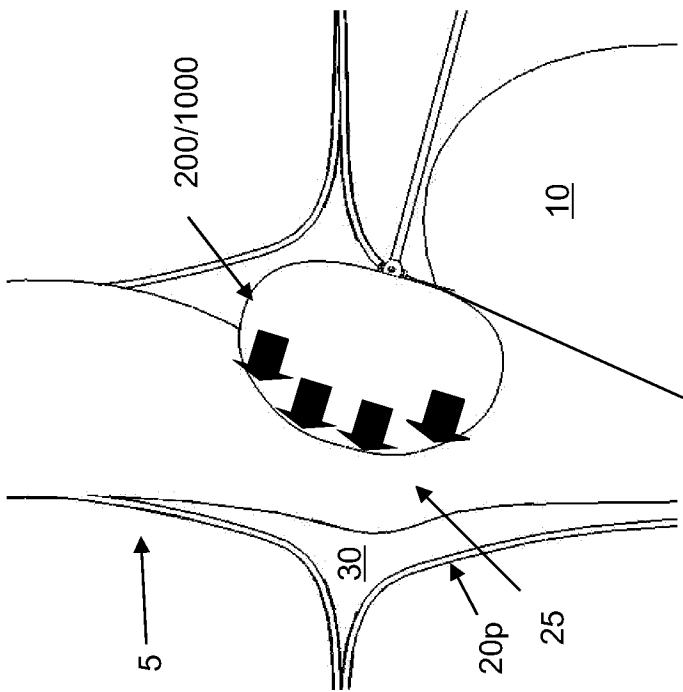

FIG. 14A

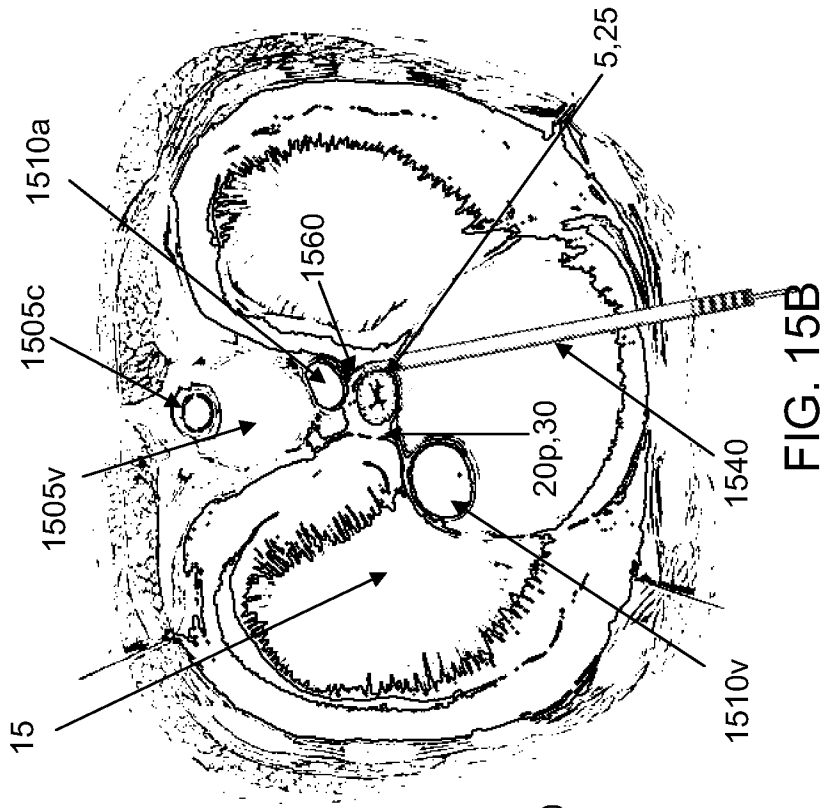

FIG. 15B

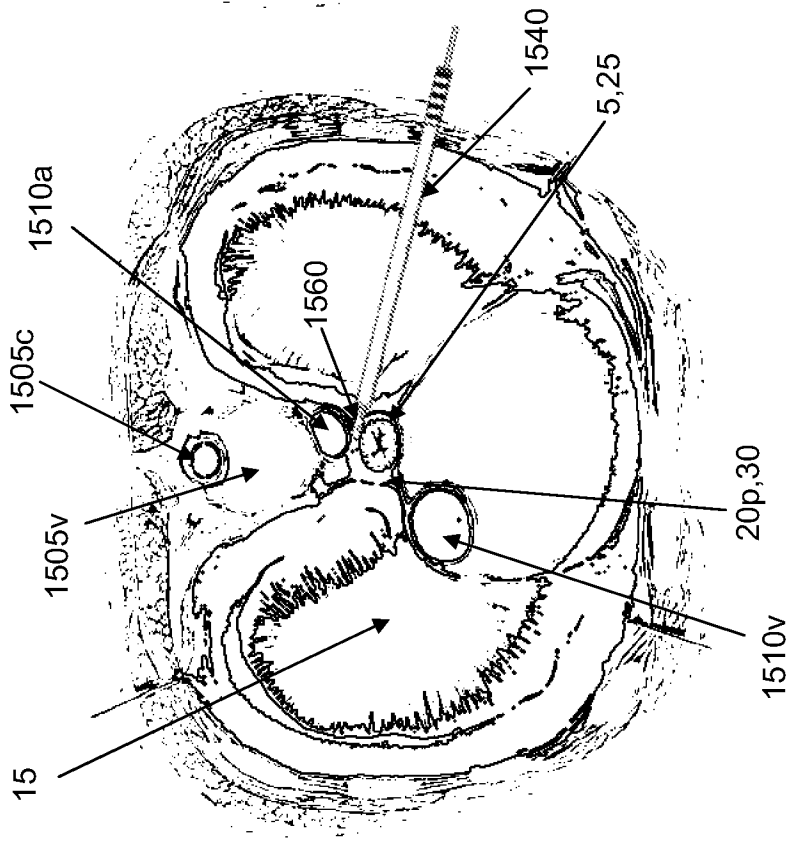

FIG. 15A

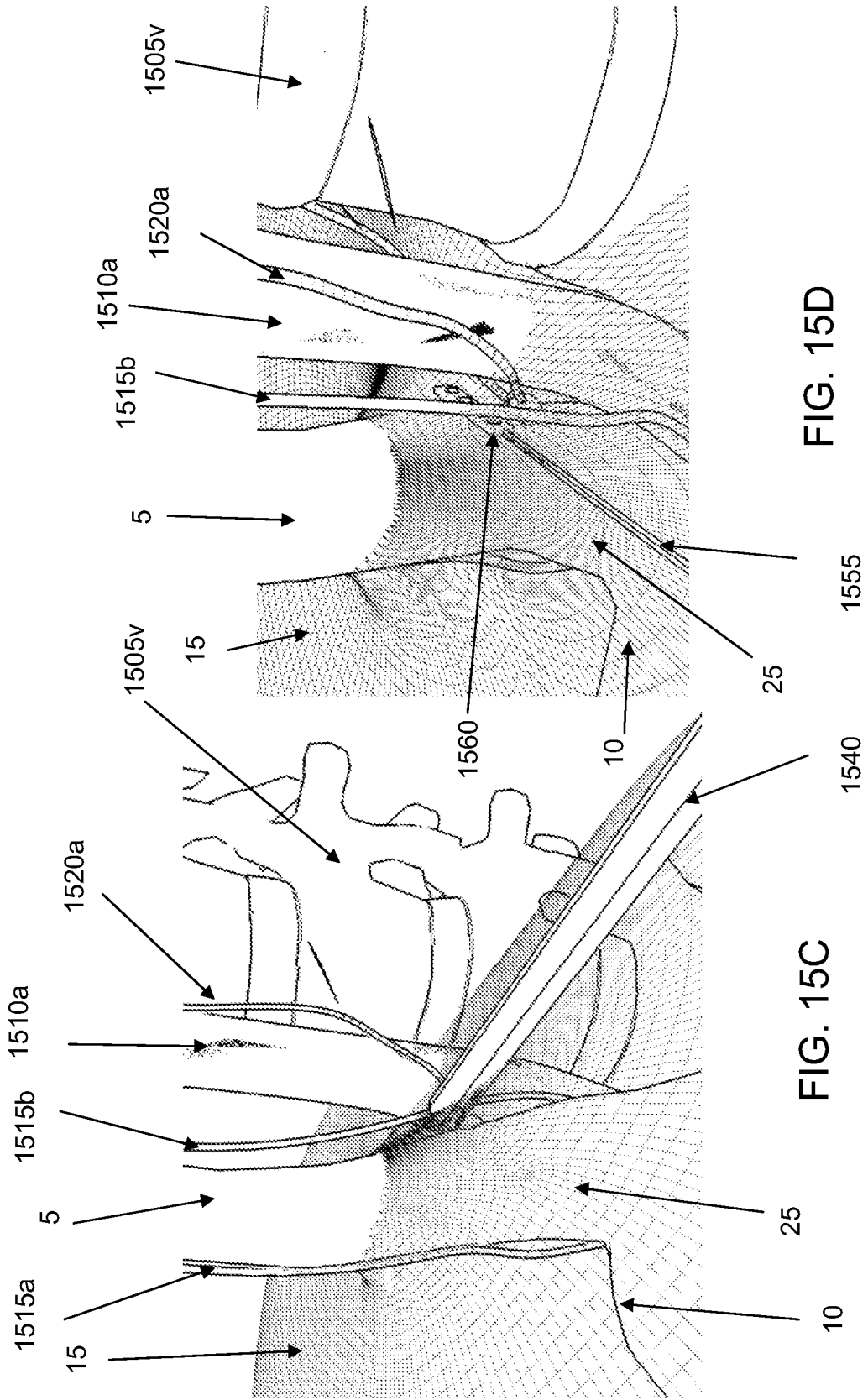

FIG. 15D

FIG. 15C

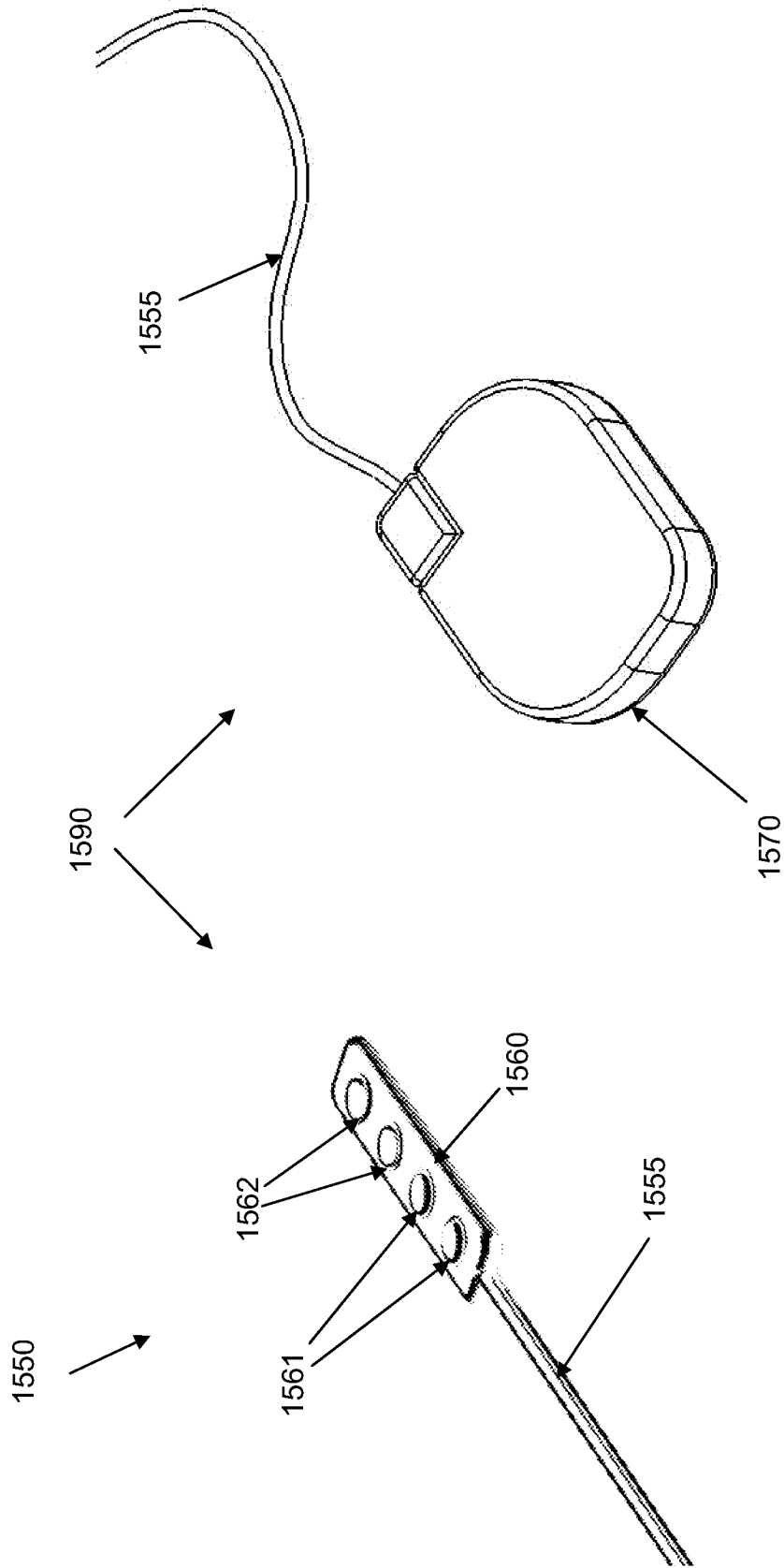

FIG. 16B

FIG. 16A

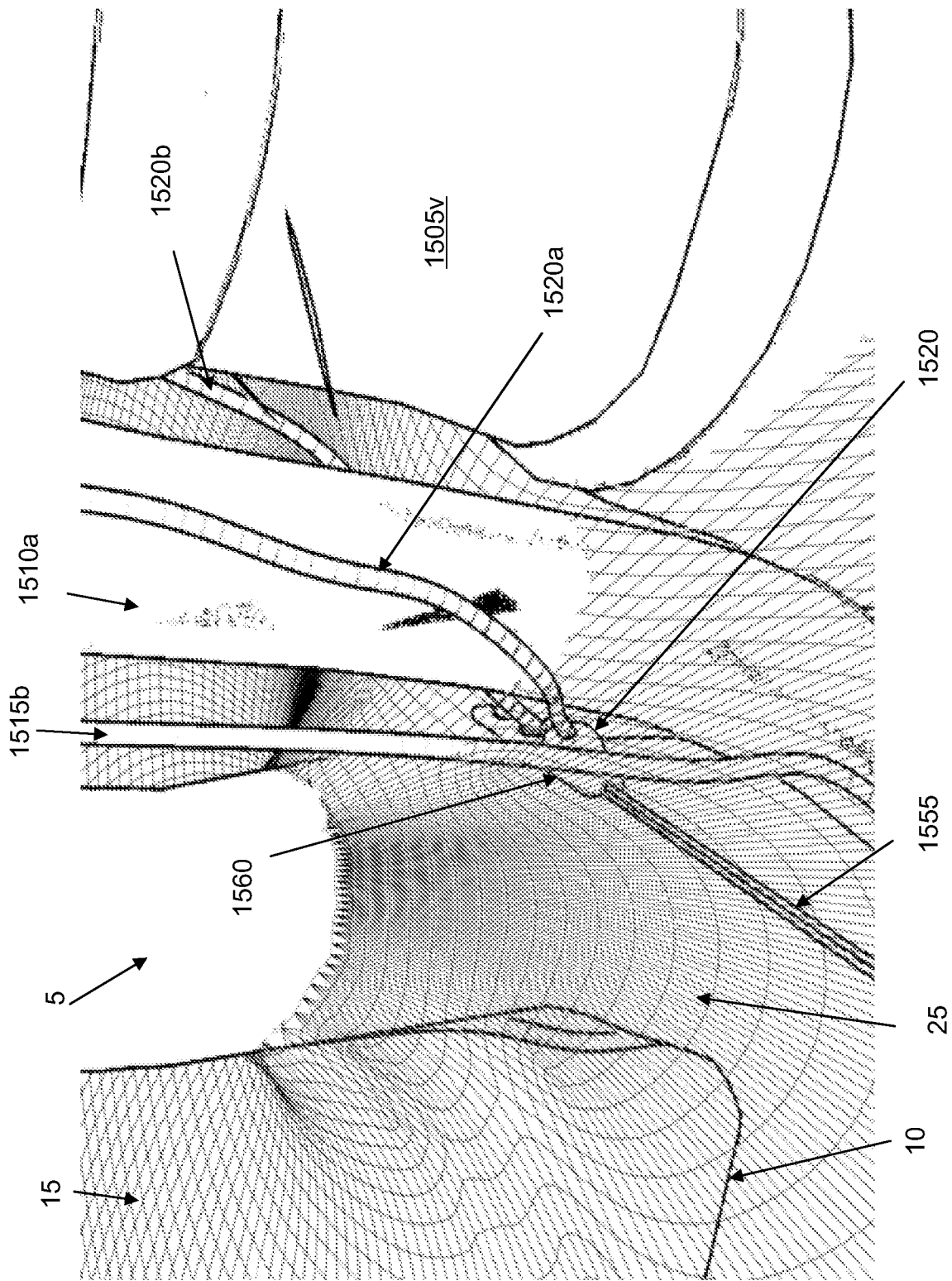

FIG. 17

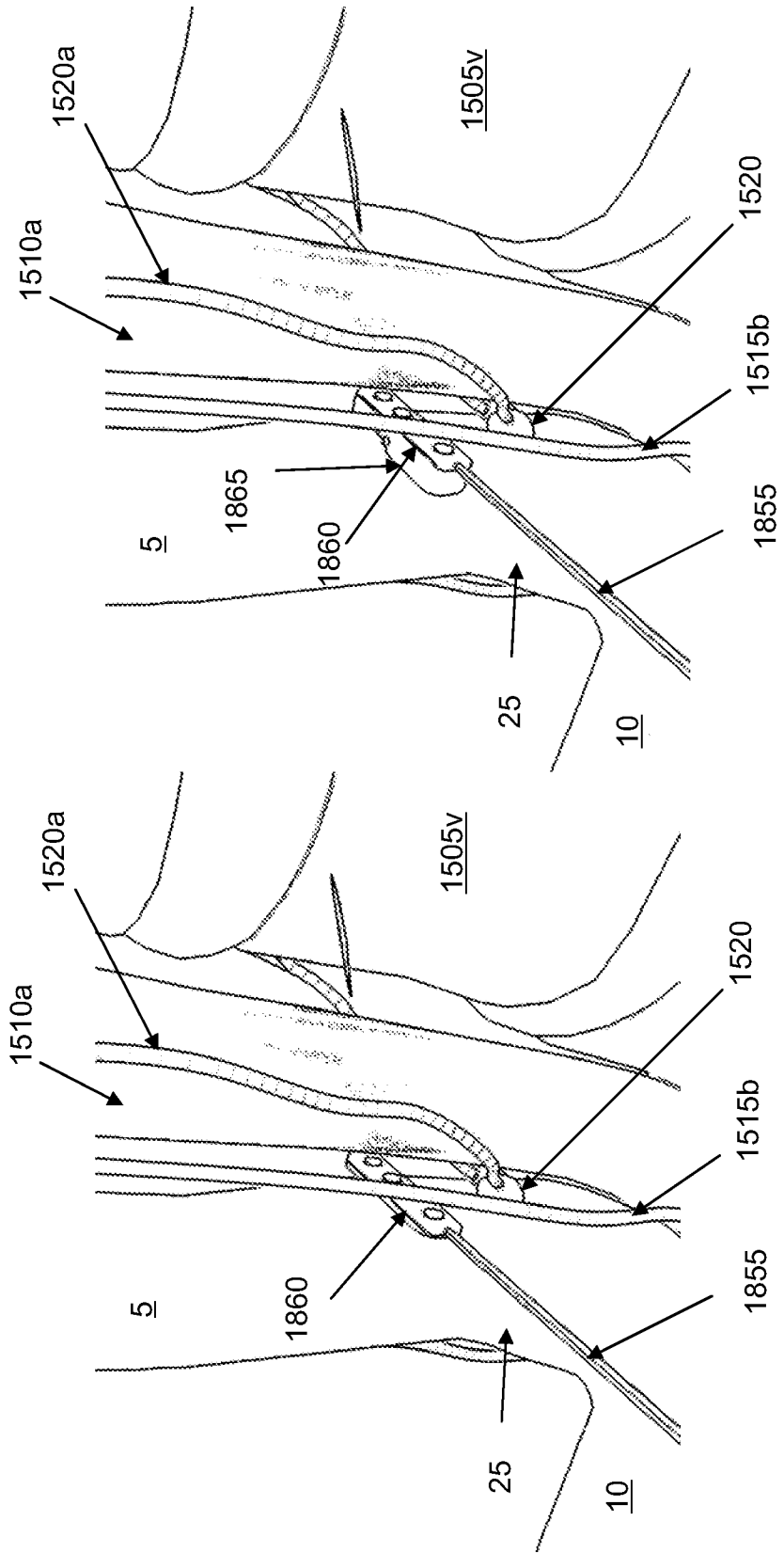

FIG. 18B

FIG. 18A

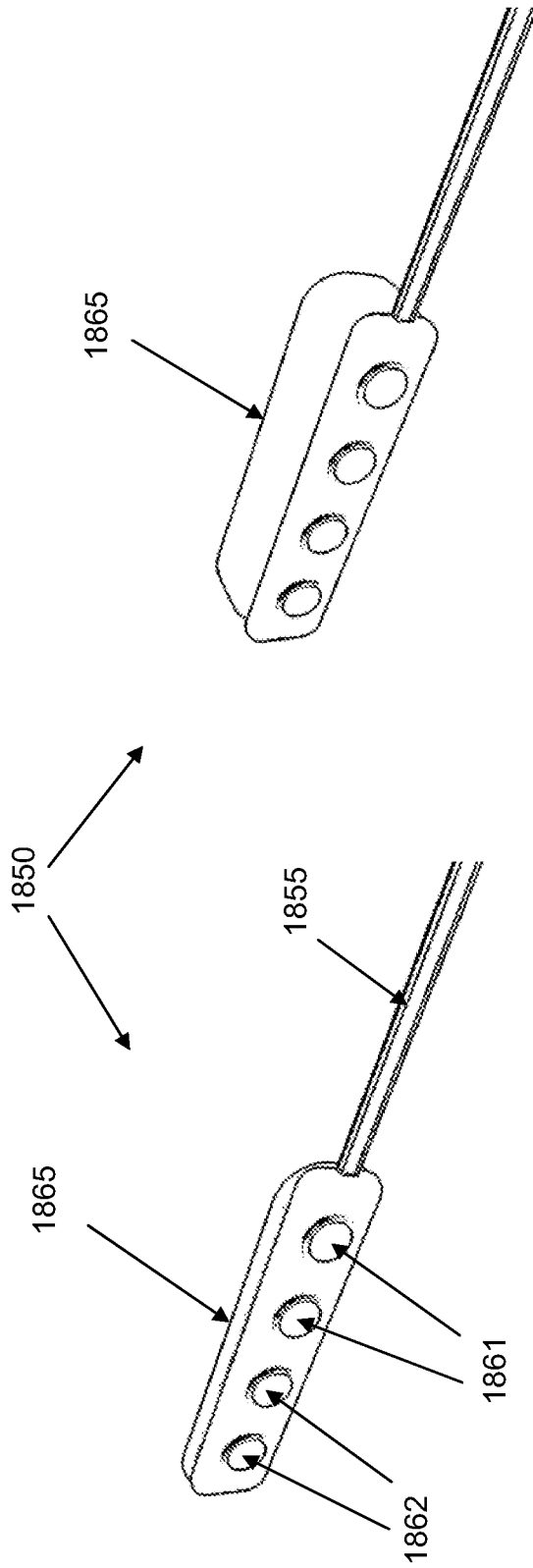

FIG. 19B

FIG. 19A

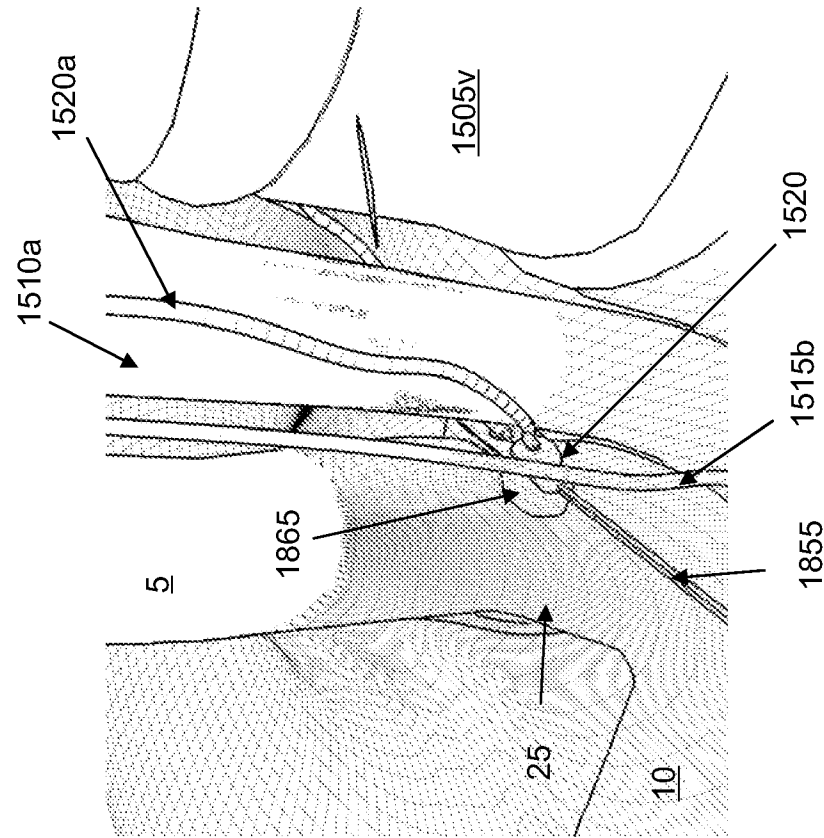

FIG. 20B

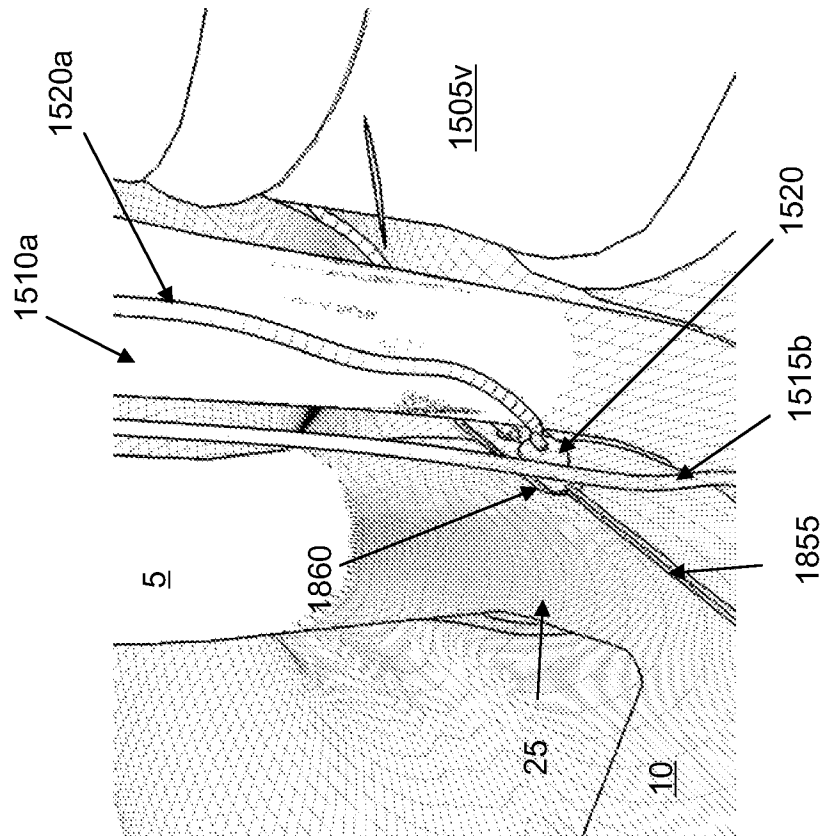

FIG. 20A

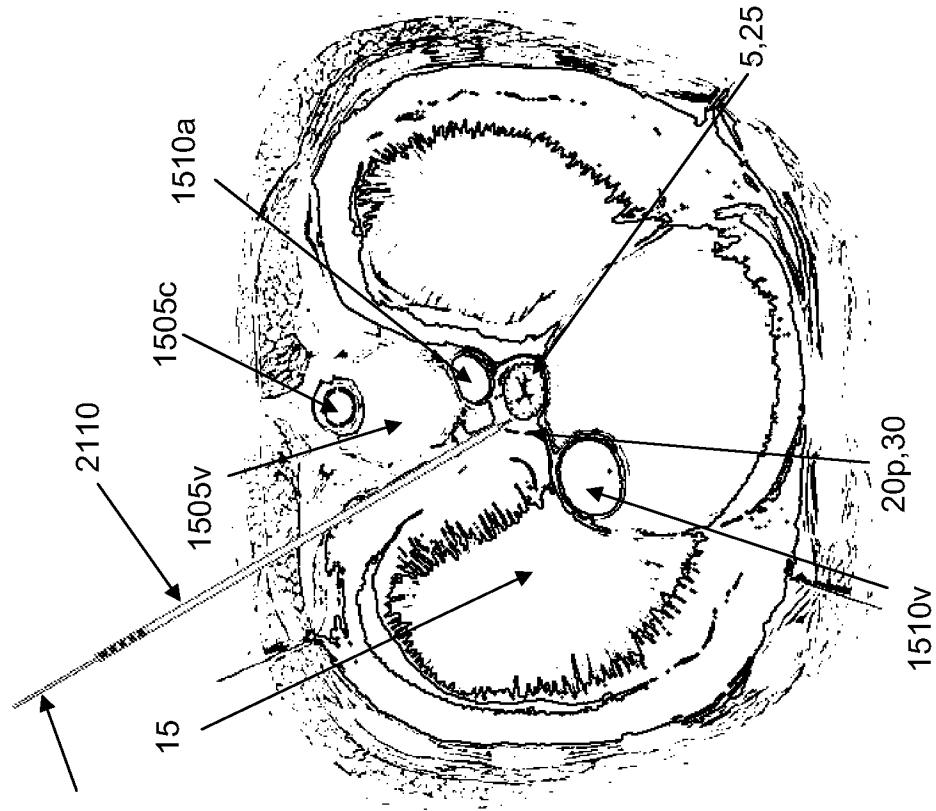

FIG. 21B

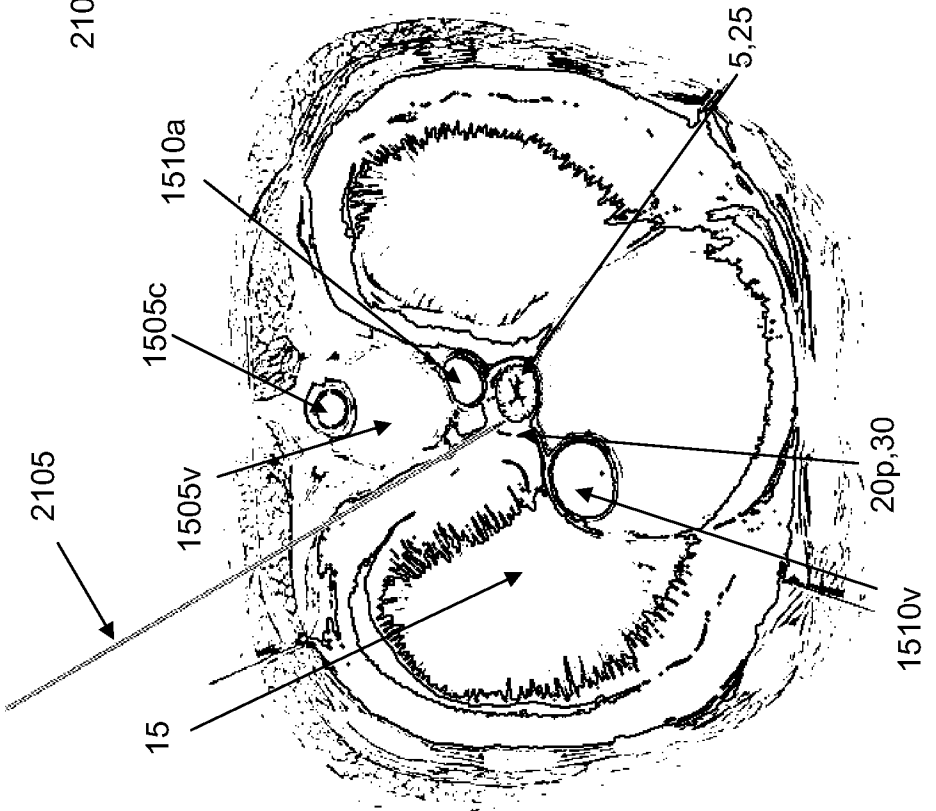

FIG. 21A

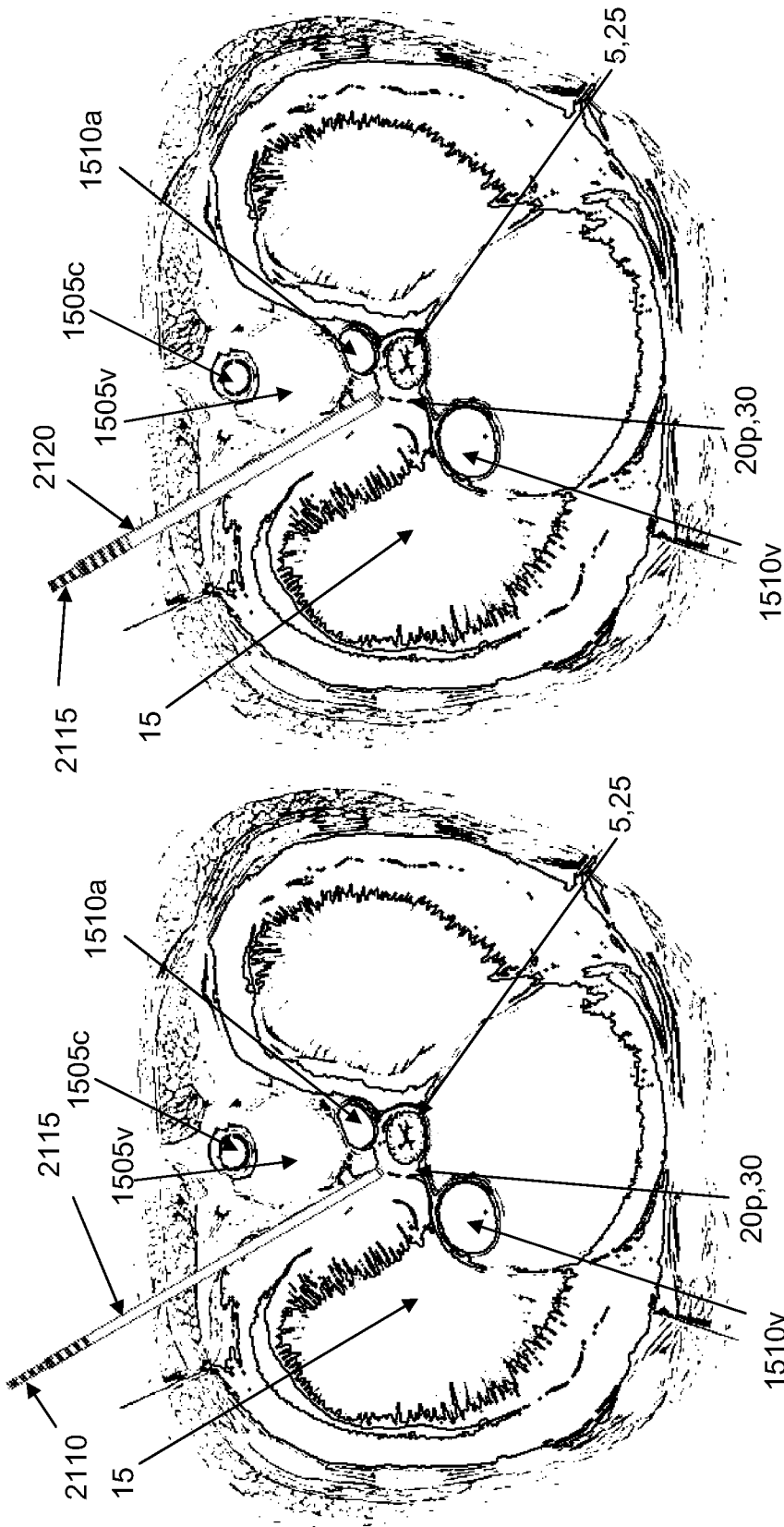

FIG. 21D

FIG. 21C

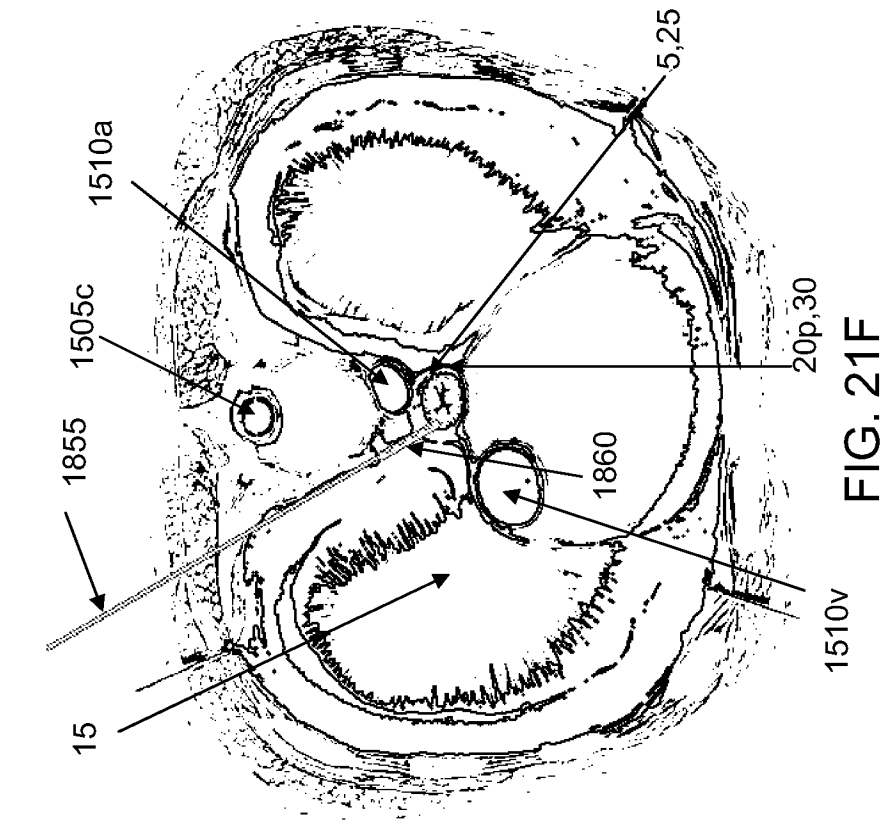

FIG. 21E

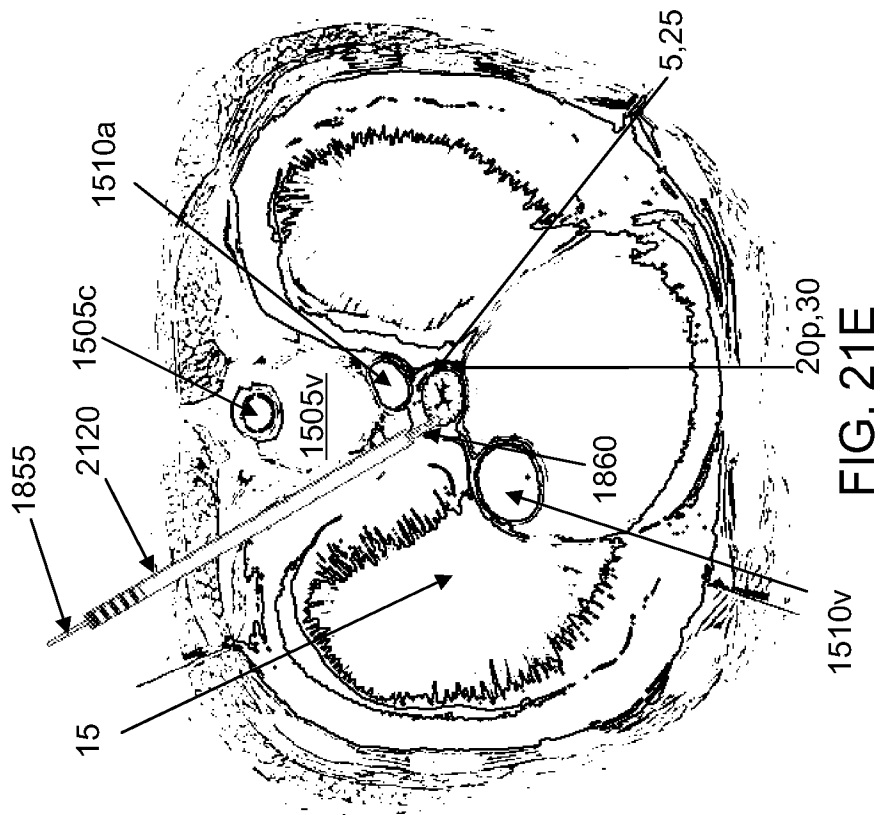

FIG. 21F

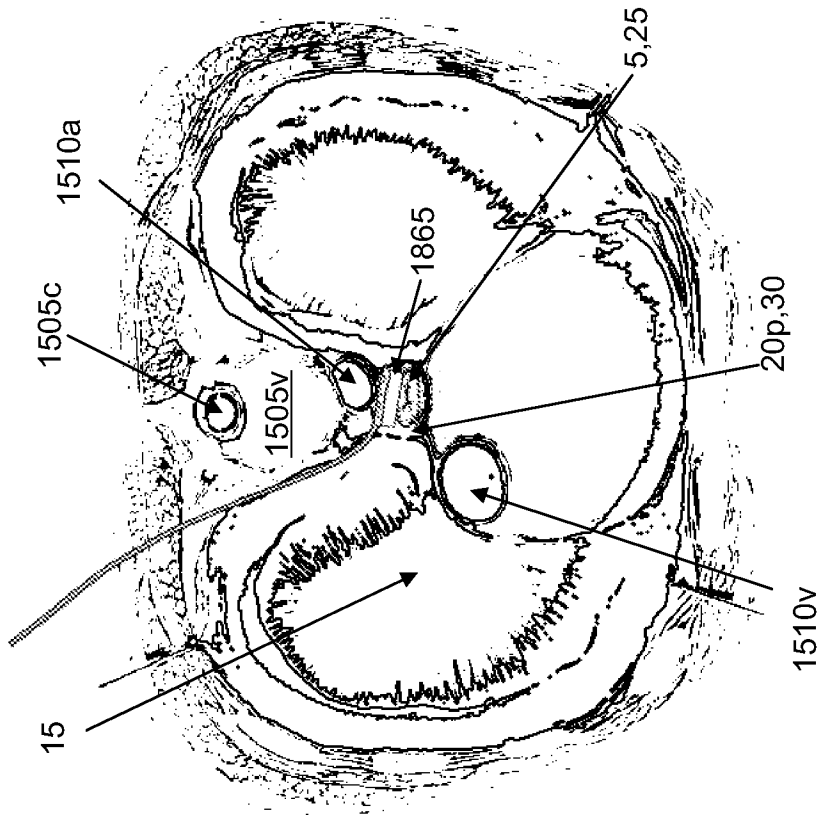

FIG. 21H

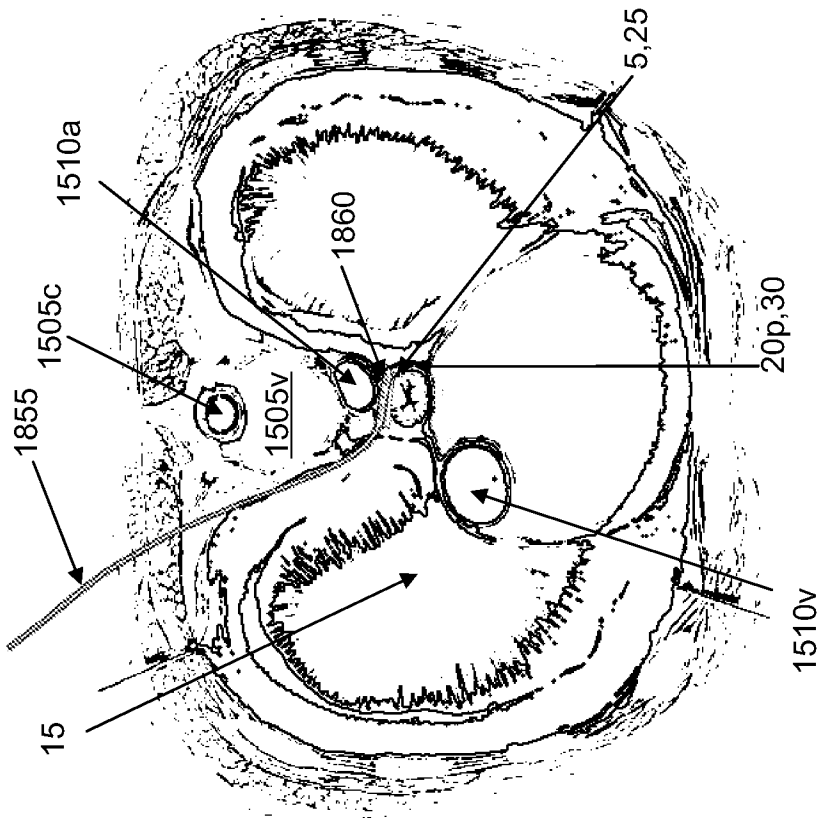

FIG. 21G

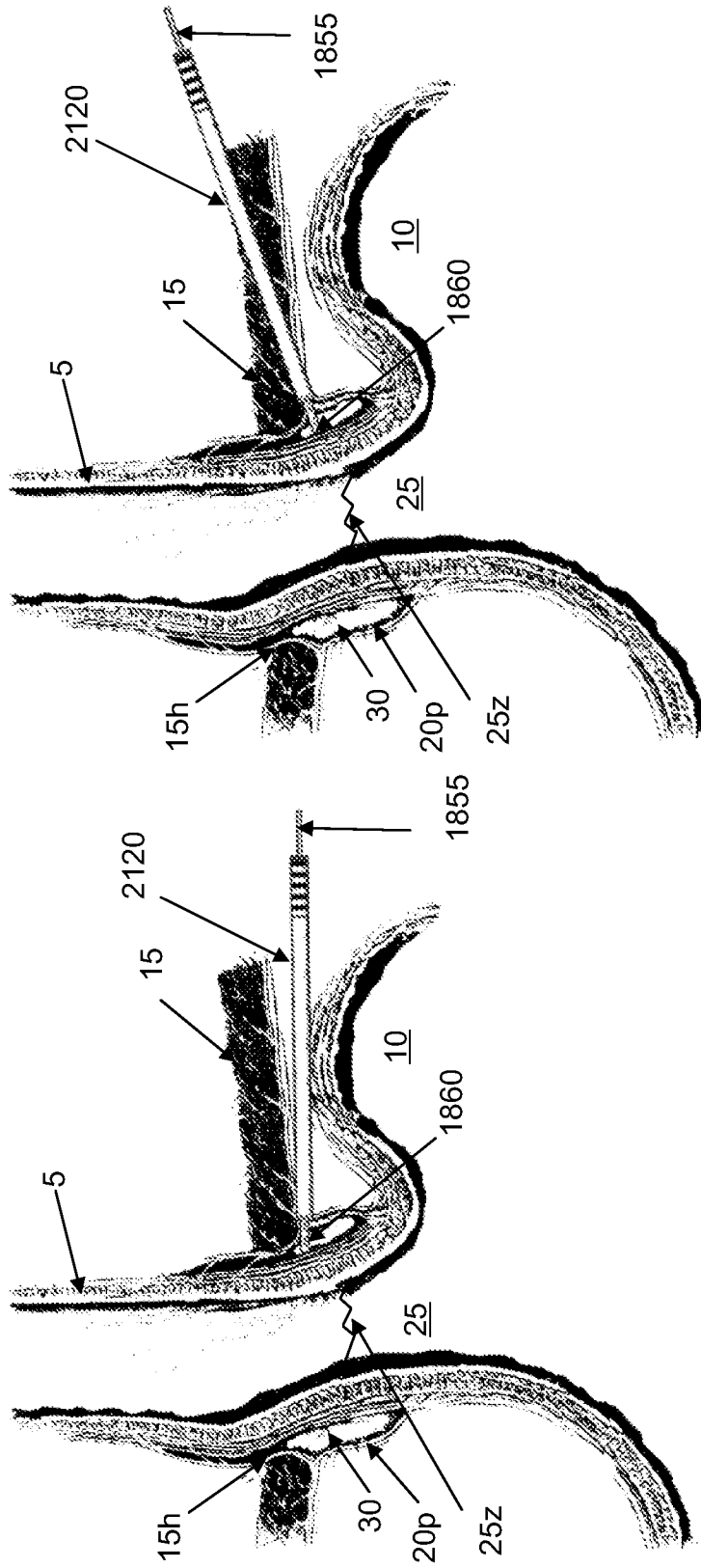

FIG. 22A

FIG. 22B

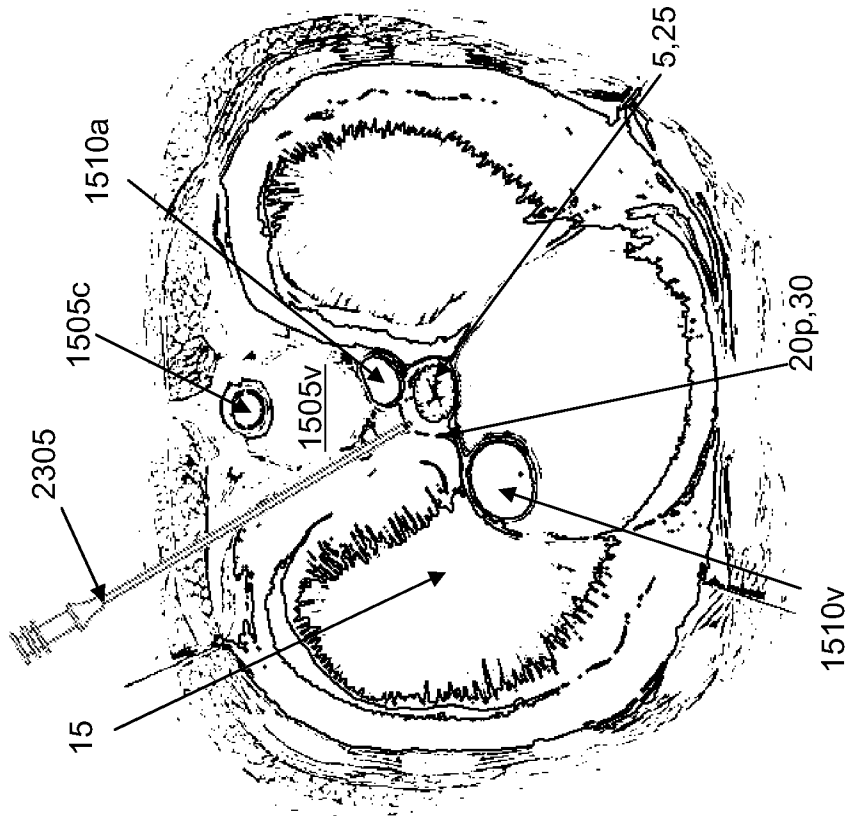

FIG. 23B

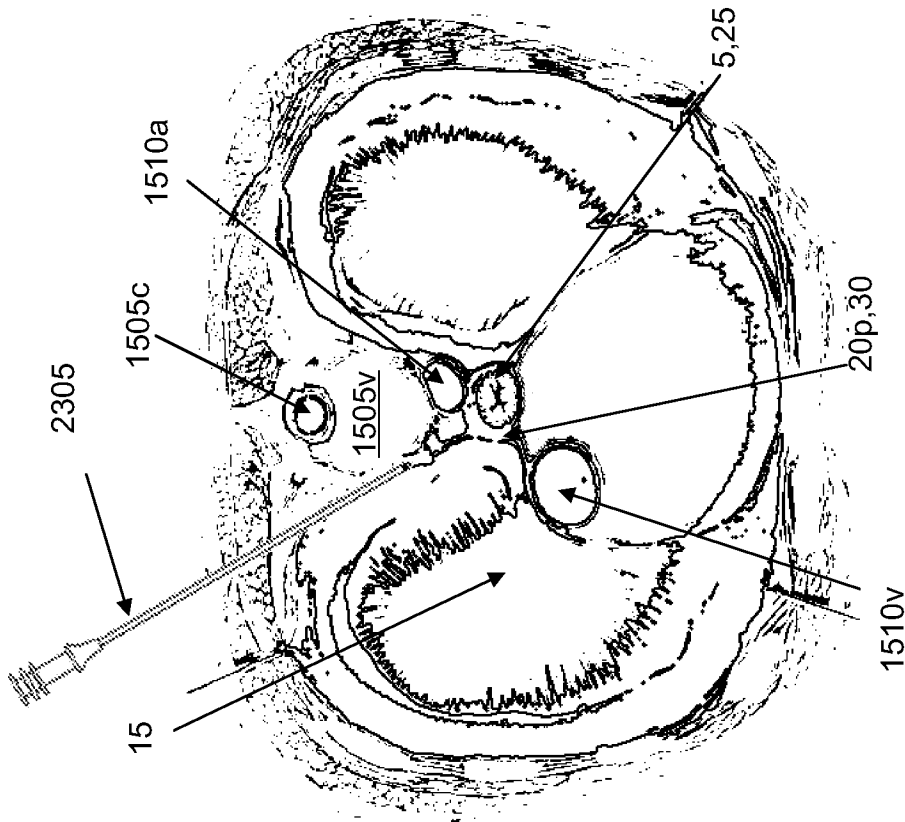

FIG. 23A

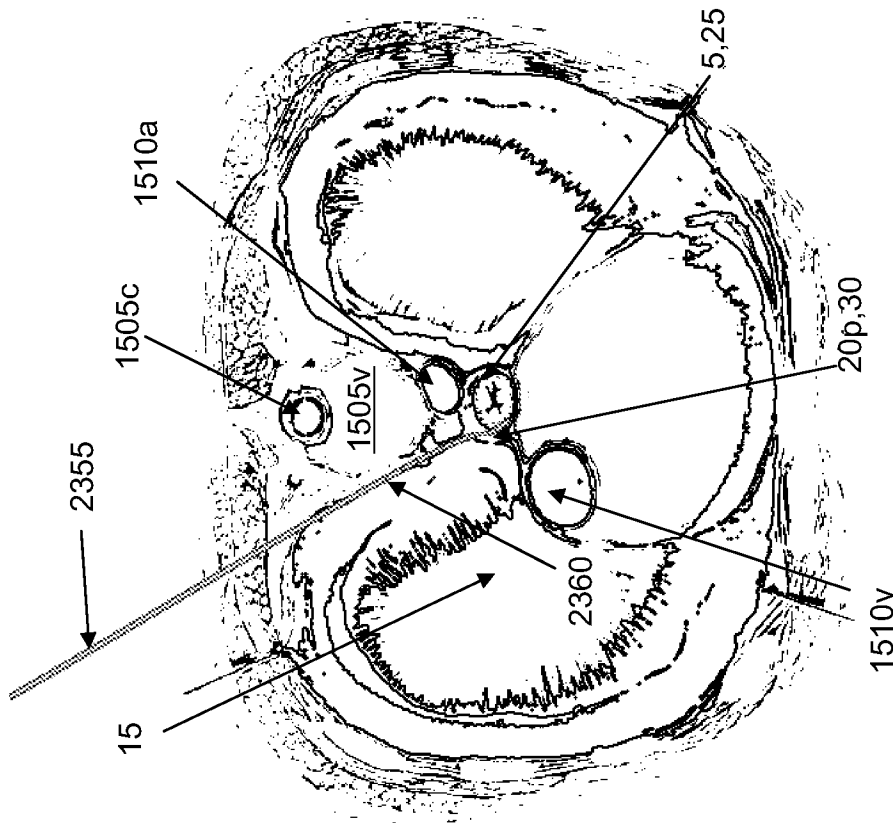

FIG. 23D

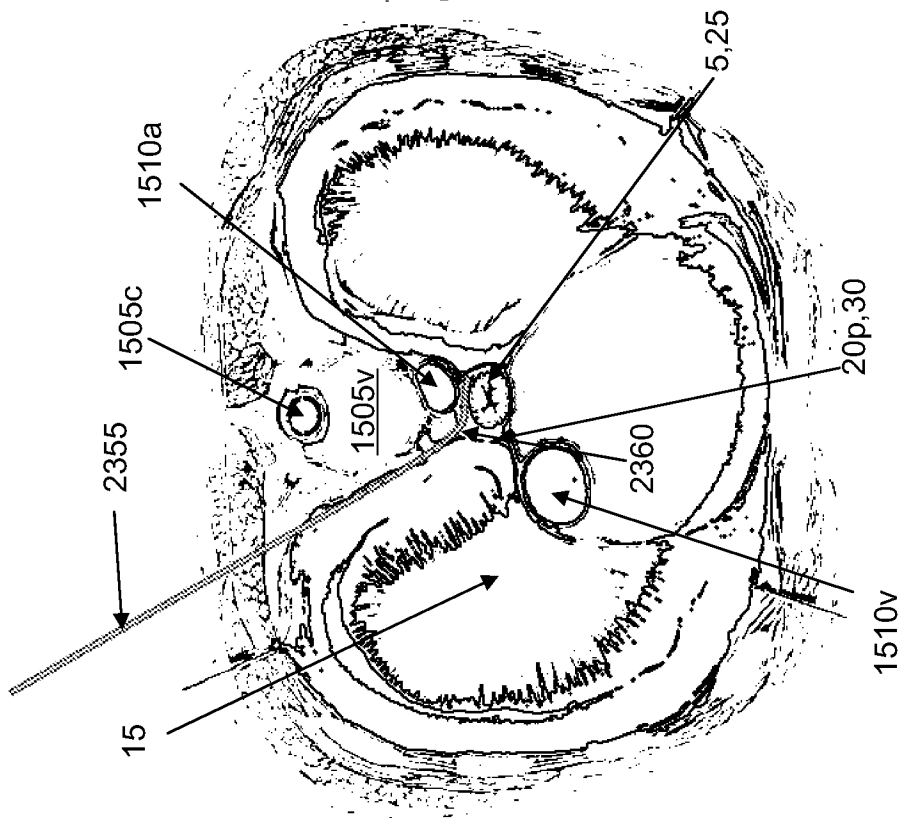

FIG. 23C

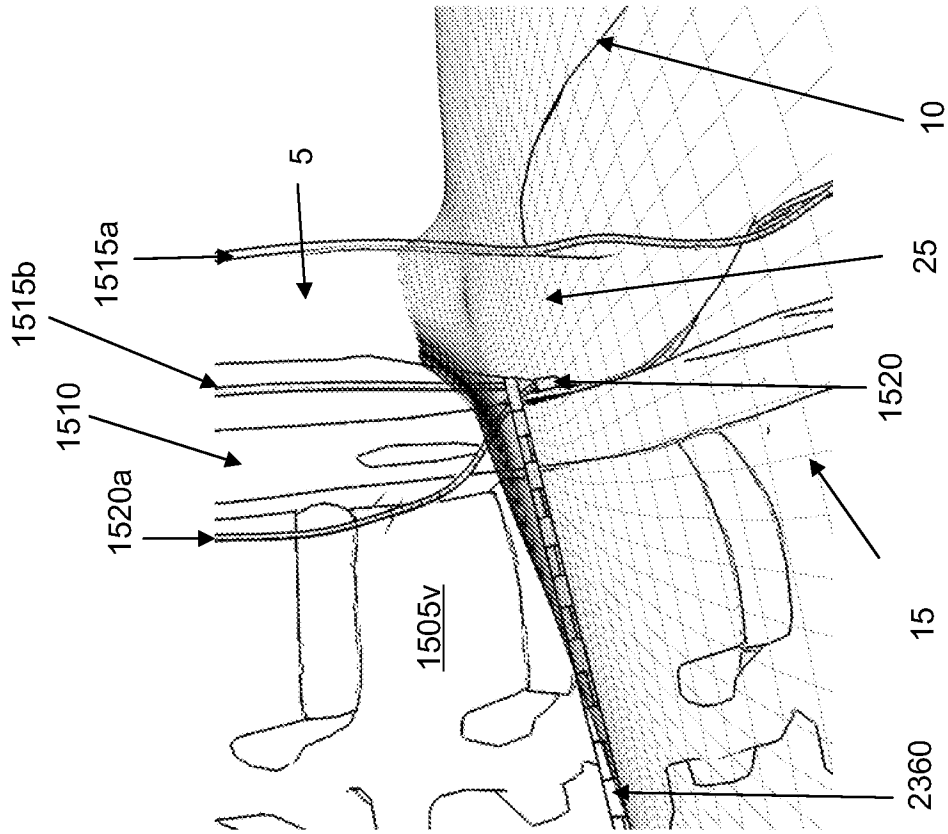

FIG. 23F

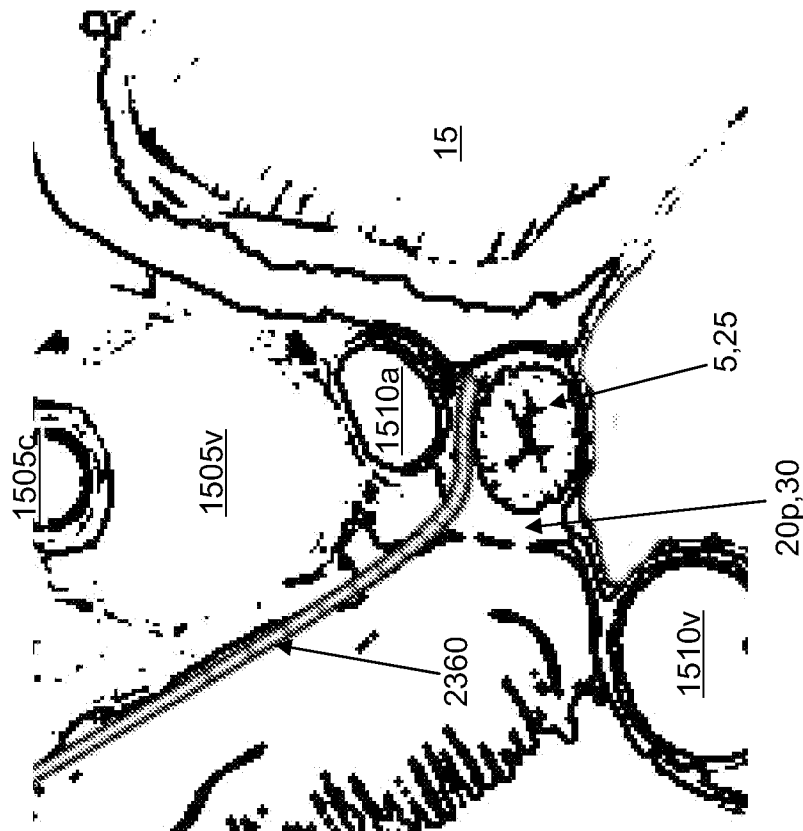

FIG. 23E

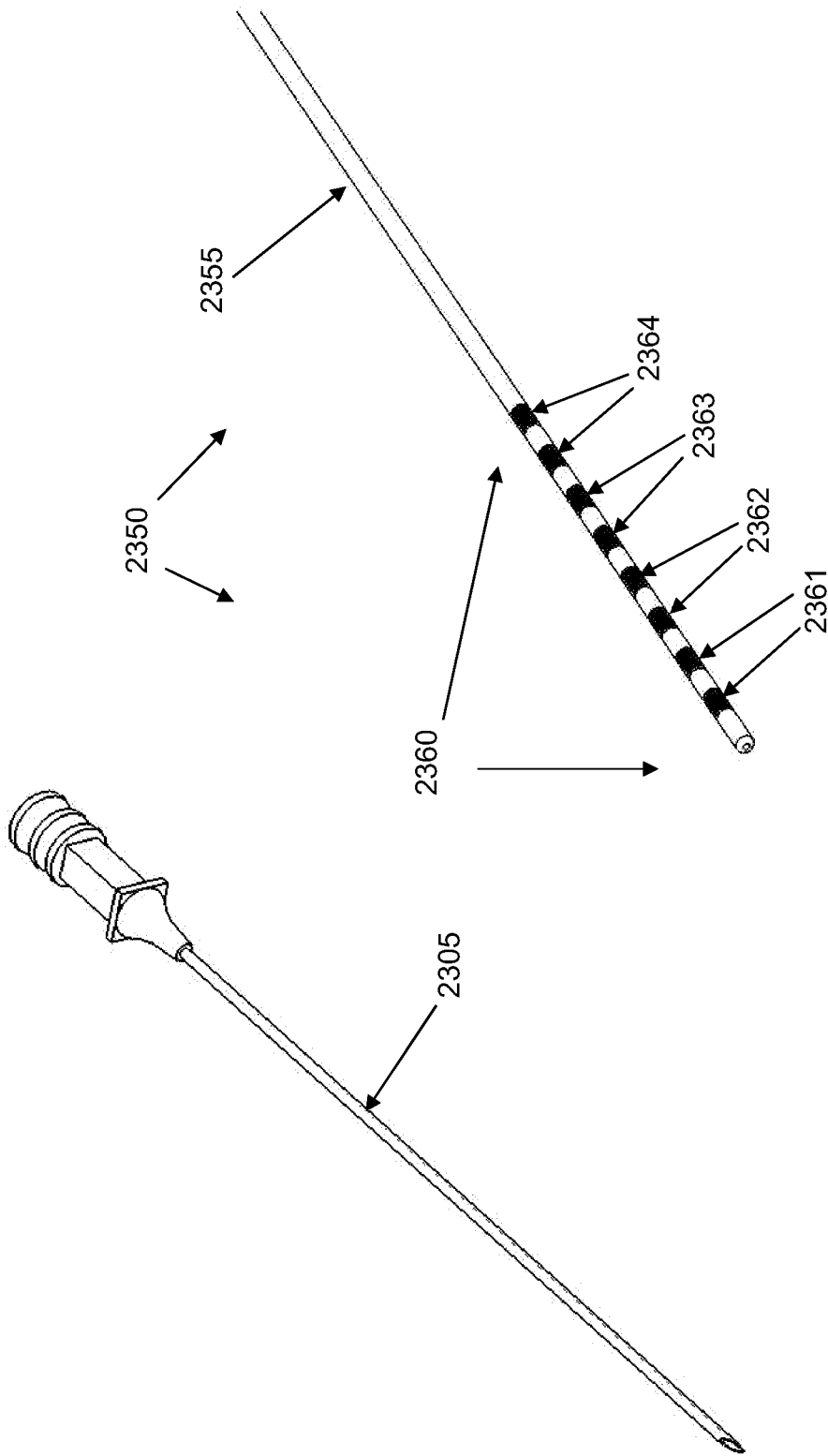

FIG. 24A

FIG. 24B

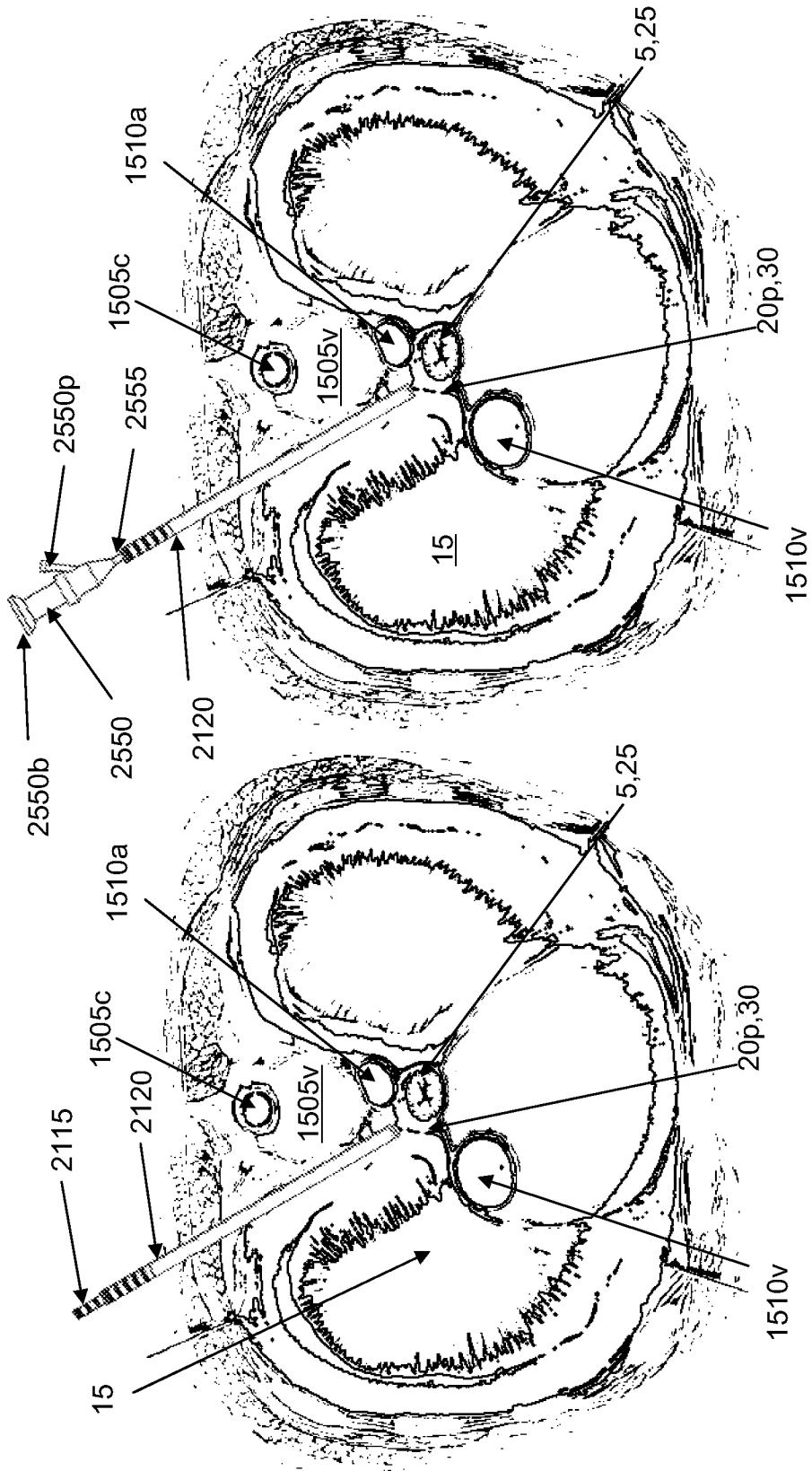

FIG. 25B

FIG. 25A

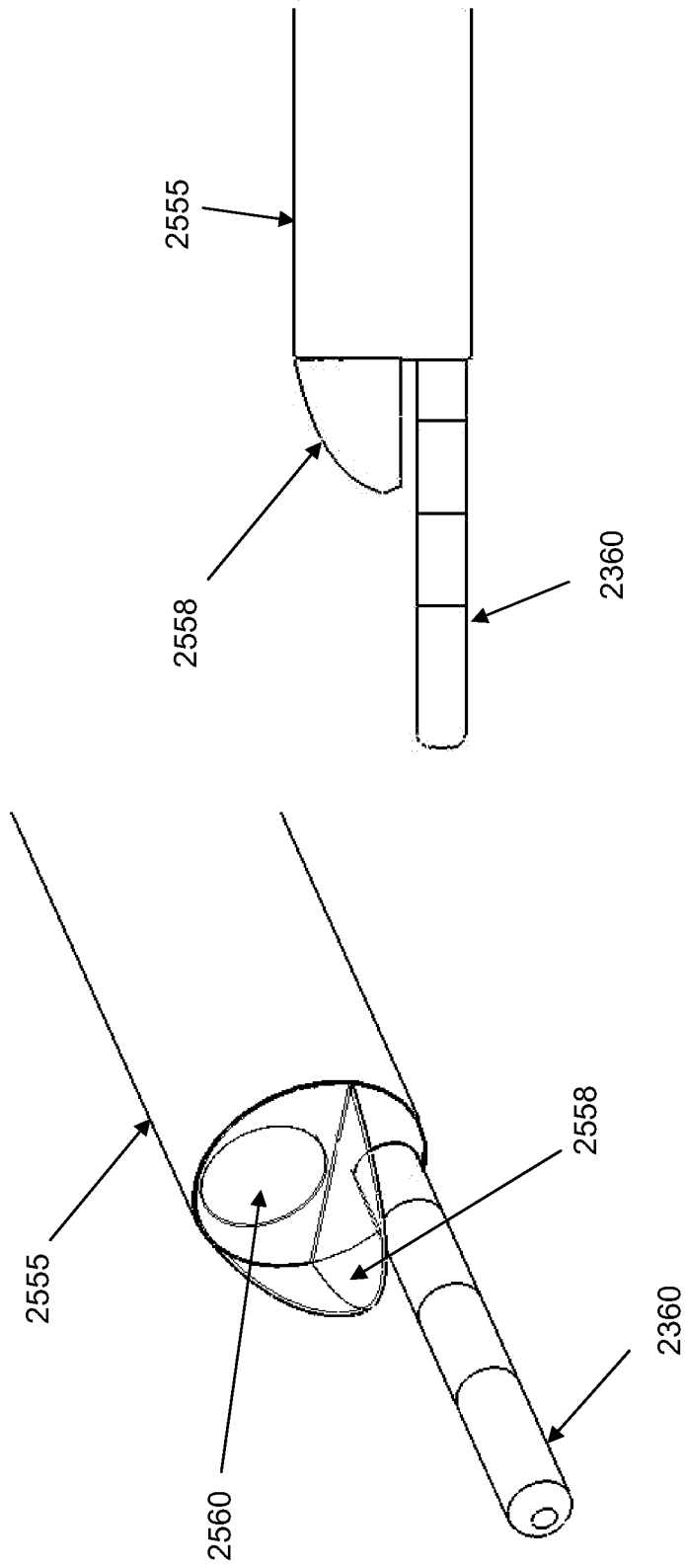

FIG. 26B

FIG. 26A

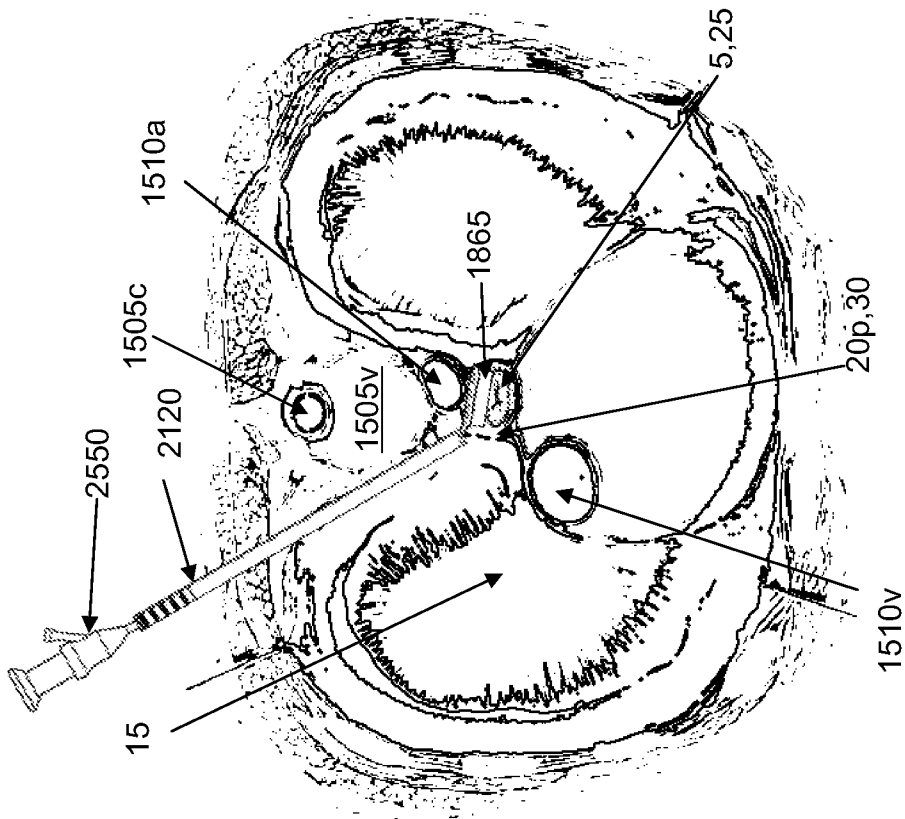

FIG. 27B

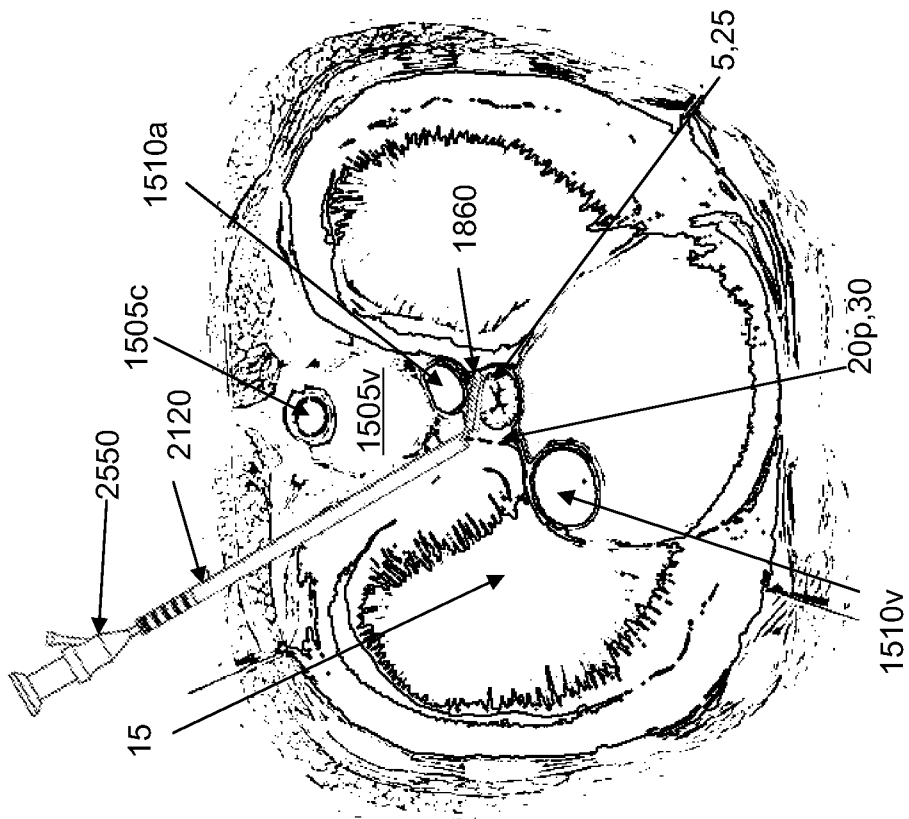

FIG. 27A

INTERNATIONAL SEARCH REPORT

International application No.
PCT/US2009/050429

A. CLASSIFICATION OF SUBJECT MATTER IPC(8) - A61N 1/04 (2009.01) USPC - 607/40 According to International Patent Classification (IPC) or to both national classification and IPC		
B. FIELDS SEARCHED Minimum documentation searched (classification system followed by classification symbols) IPC(8) - A61N 1/04 (2009.01) USPC - 606/32, 34, 41; 607/40, 62, 115, 116, 118, 133 Documentation searched other than minimum documentation to the extent that such documents are included in the fields searched Electronic data base consulted during the international search (name of data base and, where practicable, search terms used) PatBase, Google Scholar		
C. DOCUMENTS CONSIDERED TO BE RELEVANT		
Category*	Citation of document, with indication, where appropriate, of the relevant passages	Relevant to claim No.
Y	US 7,310,557 B2 (MASCHINO et al) 18 December 2007 (18.12.2007) entire document	1-47, 108-119
Y	US 2002/0193851 A1 (SILVERMAN et al) 19 December 2002 (19.12.2002) entire document	1-47, 108-119
Y	US 2004/0230255 A1 (DOBAK III) 18 November 2004 (18.11.2004) entire document	10
Y	US 2007/0049988 A1 (CARBUNARU et al) 01 March 2007 (01.03.2007) entire document	26, 27
A	WO 2008/058028 A2 (KIM et al) 15 May 2008 (15.05.2008) entire document	1-47, 108-119
<input type="checkbox"/> Further documents are listed in the continuation of Box C. <input type="checkbox"/>		
* Special categories of cited documents: "A" document defining the general state of the art which is not considered to be of particular relevance "E" earlier application or patent but published on or after the international filing date "L" document which may throw doubts on priority claim(s) or which is cited to establish the publication date of another citation or other special reason (as specified) "O" document referring to an oral disclosure, use, exhibition or other means "P" document published prior to the international filing date but later than the priority date claimed "T" later document published after the international filing date or priority date and not in conflict with the application but cited to understand the principle or theory underlying the invention "X" document of particular relevance; the claimed invention cannot be considered novel or cannot be considered to involve an inventive step when the document is taken alone "Y" document of particular relevance; the claimed invention cannot be considered to involve an inventive step when the document is combined with one or more other such documents, such combination being obvious to a person skilled in the art "&" document member of the same patent family		
Date of the actual completion of the international search 16 October 2009		Date of mailing of the international search report 29 OCT 2009
Name and mailing address of the ISA/US Mail Stop PCT, Attn: ISA/US, Commissioner for Patents P.O. Box 1450, Alexandria, Virginia 22313-1450 Facsimile No. 571-273-3201		Authorized officer: Blaine R. Copenheaver PCT Helpdesk: 571-272-4300 PCT OSP: 571-272-7774

INTERNATIONAL SEARCH REPORT

International application No.

PCT/US2009/050429

Box No. II Observations where certain claims were found unsearchable (Continuation of item 2 of first sheet)

This international search report has not been established in respect of certain claims under Article 17(2)(a) for the following reasons:

1. Claims Nos.:
because they relate to subject matter not required to be searched by this Authority, namely:

2. Claims Nos.:
because they relate to parts of the international application that do not comply with the prescribed requirements to such an extent that no meaningful international search can be carried out, specifically:

3. Claims Nos.:
because they are dependent claims and are not drafted in accordance with the second and third sentences of Rule 6.4(a).

Box No. III Observations where unity of invention is lacking (Continuation of item 3 of first sheet)

This International Searching Authority found multiple inventions in this international application, as follows:

Group I, claims 1-47, 108-119 are drawn to methods for using electrodes in gastroesophageal space.

Group II, claims 48-107 are drawn to methods for introducing an inflatable element to a digestive space.

The inventions listed in Groups I and II do not relate to a single general inventive concept under PCT Rule 13.1, because under PCT Rule 13.2 they lack the same or corresponding special technical features for the following reasons:

The special technical features of Group I, methods for introducing an electrode system into a patient by endoscopic means, are not present in Group II; and the special technical features of Group II, methods for introducing an electrical stimulation system by means of an inflatable element such as a balloon, are not present in Group I.

Since none of the special technical features of the Group I and II inventions are found in more than one of the inventions, unity is lacking.

1. As all required additional search fees were timely paid by the applicant, this international search report covers all searchable claims.
2. As all searchable claims could be searched without effort justifying additional fees, this Authority did not invite payment of additional fees.
3. As only some of the required additional search fees were timely paid by the applicant, this international search report covers only those claims for which fees were paid, specifically claims Nos.:
4. No required additional search fees were timely paid by the applicant. Consequently, this international search report is restricted to the invention first mentioned in the claims; it is covered by claims Nos.:
1-47, 108-119

Remark on Protest

- The additional search fees were accompanied by the applicant's protest and, where applicable, the payment of a protest fee.
- The additional search fees were accompanied by the applicant's protest but the applicable protest fee was not paid within the time limit specified in the invitation.
- No protest accompanied the payment of additional search fees.