

(No Model.)

J. J. BILLINGSLEY.

CAR COUPLING.

No. 372,111.

Patented Oct. 25, 1887.

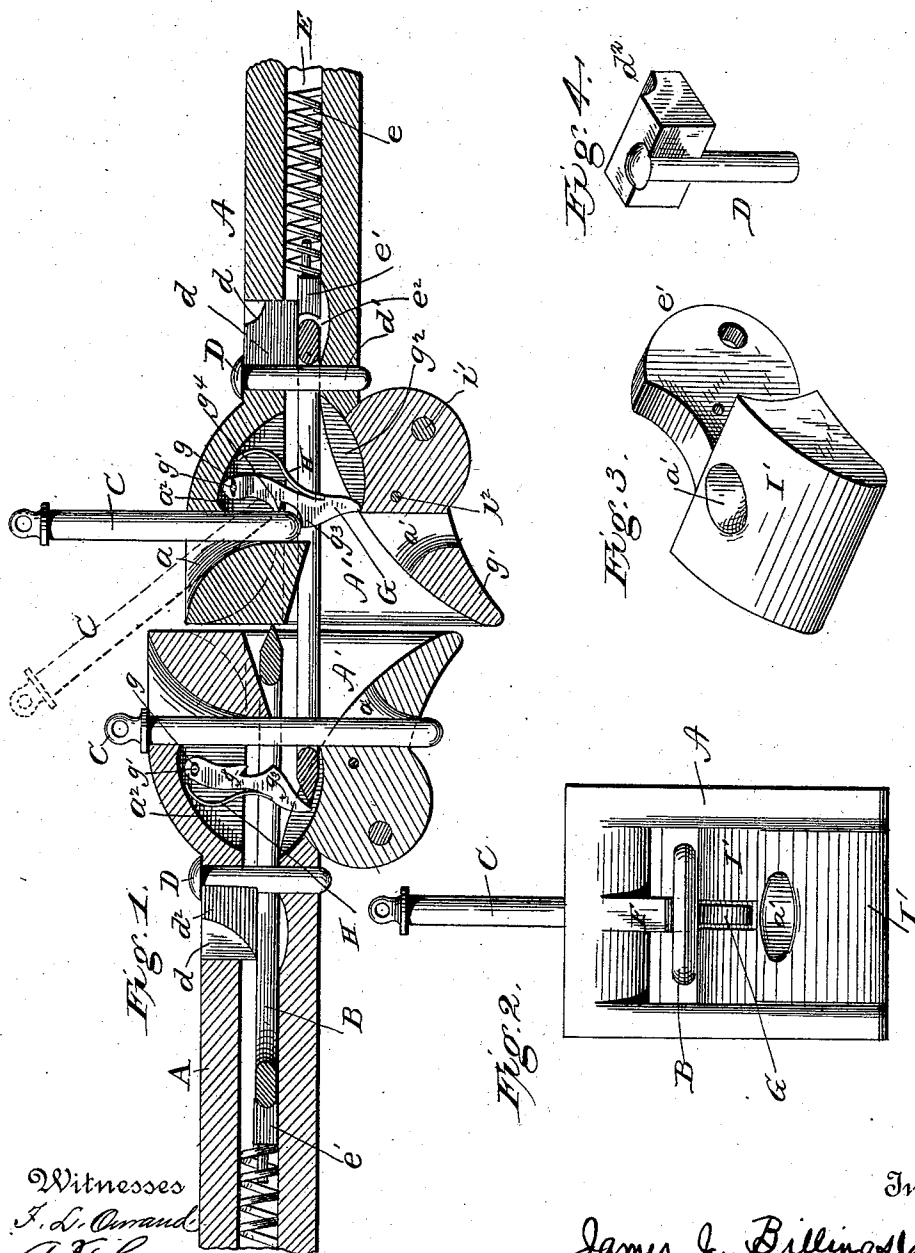

Witnesses
J. L. Ormand
A. F. Green

Inventor
James J. Billingsley
 By his Attorney
Frank A. Fouts

UNITED STATES PATENT OFFICE.

JAMES J. BILLINGSLEY, OF MINDEN, LOUISIANA.

CAR-COUPLING.

SPECIFICATION forming part of Letters Patent No. 372,111, dated October 25, 1887.

Application filed January 23, 1887. Serial No. 225,136. (No model.)

To all whom it may concern:

Be it known that I, JAMES J. BILLINGSLEY, a citizen of the United States, residing at Minden, in the parish of Webster and State of Louisiana, have invented certain new and useful Improvements in Car-Couplers; and I do hereby declare the following to be a full, clear, and exact description of the invention, such as will enable others skilled in the art to which it appertains to make and use the same.

My invention relates to car-couplings; and it consists in the parts which will be hereinafter described, and pointed out in the claims.

In the accompanying drawings, Figure 1 represents a central longitudinal sectional view of two draw-heads coupled, constructed in accordance with my invention. Fig. 2 is a front view looking into the jaws of one draw-head. In this view the front pin is shown raised. Fig. 3 is a perspective of the lower pivotal jaw detached, and Fig. 4 is a perspective view of a weight having one of the rear pins secured thereto.

Like letters indicate like parts in the several views.

The principal objects of my invention are to construct a device capable of coupling automatically, and of automatically uncoupling when the cars are driven together by excessive force, such as would occur in an accident.

Referring to the accompanying drawings, the letter A designates one of the draw-heads, B a link, and C one of the front pins.

The draw-head A is provided with a link-recess, A', and the top and bottom openings, a a', for the reception of the coupling-pin C. The upper opening, a, has its outer orifice enlarged, the front wall being rounded from below outward. a² is a transverse notch or recess in the rear of the opening a and communicating therewith.

D is a short pin provided with a weight, d². This weight is extended, preferably lengthwise, through a vertical longitudinal slot, d, made in the draw-head. Said longitudinal slot is preferably made of small width, so as not to weaken the draw-head. It may be a foot in length, if necessary. It is located in the rear of the opening a, and it is sufficiently large to receive the pin D and its weight.

d¹ is an opening in the under side of the draw-head for the reception of the lower end

of the pin D. Said pin passes through the link and retains the same in the draw-head. The object of the weight is to hold the pin D and link in position. The weight rests upon the inner top side of the link, and thereby serves to hold said link in a horizontal position. The weight is preferably fixed to the pin, although it may not be so.

E is a longitudinal opening in the draw-head. This opening is provided with a coiled spiral spring, e. The outer end of this spring bears against the movable block e'. This block is provided with a shank which extends rearward and lies partly in the spring. The rear end of the link rests against the outer recessed end of said block. The tendency of the block and spring is to force the link outward. The link and block may be forced back into the longitudinal recess E, thereby compressing the spring.

e² is a concave recess immediately under the opening d. This recess permits a free vertical movement of the inner end of the link.

F is a central projection on the under side of the upper jaw. This projection extends inward and tapers downward. It extends to a point below the end of the pin C when the latter is raised. The inner end of said projection lies between the two parallel sides of the link and serves to retain said link in a straight line with the draw-head. The front vertical face of said projection prevents the overriding link from entering the opposite draw-head.

G is a swinging dog provided with a short horizontal slot, g. The dog is pivotally secured in the recess a² by the pin g', which passes through the slot g. The lower end of the dog swings in a concave recess, g². g³ and g⁴ are shoulders on the front side of the dog. The shoulder g³ receives the point of the pin and supports the same in a vertical position, while the shoulder g⁴ supports the point of the pin when the latter is inclined forward.

H is a plate-spring having its upper end secured within the link-recess, with its free end pressing against the rear side of the dog, whereby the latter is forced outward, so that the lower end of the same impinges against the front shoulder of the concave recess g².

The lower jaw of the draw-head is made in two parts—an inner part, I, deeply recessed centrally from top to bottom, and an outer

part, I', having a shank, *i*, which is secured in the recess in the part I. Said shank is secured in the recess by pivotal bolt *i'* and the pin *i''*. The pivotal action of the jaw I' will be hereinafter specified.

The outer ends of the links are wedge-shaped, so that one will override the other when the two draw-heads are brought together. Neither link disengages from its pin D in the draw-head; but when the draw-heads come together the wedged end of one link overrides the other and, being depressed thereby, enters the opposite draw-head. The link in entering strikes the lower outer end of the dog and forces the latter backward, thereby permitting one coupling-pin, C, to fall, so that its lower end shall engage the opening *a'* in the lower jaw. The end of the other (upper) link, striking against the upper side of the outer end of the opposing draw-head, is driven backward on its spring *e*. The inner end of said link and block *e'* are forced into the recess E. It will be observed that only one pin falls in coupling. The front end of each draw-head is made vertically straight at K, so that the upper or overriding link, which does not couple, may be prevented from entering the jaws of the opposing draw-head, as shown in Fig. 1.

When the cars are standing coupled together, the dog being swung inward by the link, the coupling-pin C may be lifted and inclined forward, with its point resting on the shoulder *g'* of the dog. The cars are now uncoupled, and when moved apart and the link drawn out from the draw-head the spring H will force the dog outward and the shoulder *g'* will force the pin C into a vertical position, so that its end will fall upon the shoulder *g''* and the pin will be in a position to again couple.

Should the draw-heads be violently forced together by an accident, the pins *i''*, which retain the pivotal jaws I', will be broken by the impact of the draw-heads. Said jaws will thereby turn downward on their pivotal bolts *i'* and disengage the lower ends of the coupling-pins C from the openings *a'* in said jaws, so that should one of the cars turn over the link thereof will be forced downward and disengaged from the corresponding coupling-pin and uncouple the falling car.

The horizontal slot *g* in the dog permits said dog to be forced backward horizontally at first by the entering link, so as to more quickly release the coupling-pin, the point of said pin prior to the entry of the link being mounted on the shoulder *g''* of the dog. When so mounted, the pin is in a vertical position. The instant the dog is forced back by the entering link the pin C drops and its lower end engages the opening *a'* in the lower jaw, thereby engaging and retaining the link.

Having thus described my invention, I claim as new and desire to secure by Letters Patent—

1. A car-coupling having an opening in its top and a lower jaw having an opening nor-

mally in alignment with said top opening, and a coupling-pin for engaging said openings, said lower jaw being secured by a retaining-pin and a pivotal bolt, whereby when two draw-heads are forcibly driven together, as by an accident, the retaining-pin will be broken and the jaw turned downward on its pivotal bolt and the lower end of the coupling-pin disengaged from the lower jaw, substantially as specified.

2. The combination of a car-coupler provided with a longitudinal recess in its shank, a spiral spring in said recess, a link, and a pin for retaining the link, said recess being adapted to receive the link, whereby the link may be wholly forced into the draw-head and forced out when released by the action of the spring, substantially as specified.

3. A draw-head provided with the projection F on its upper under side, said piece having a vertical front face, substantially as described.

4. A draw head provided with the projection F on its upper under side, said piece having a vertical front face, said draw-head being also provided with a link secured therein, the outer end of said link being wedge shape, substantially as specified.

5. In a car-coupler, the combination, with the recessed draw-head, of the notched pivoted spring-actuated dog and the pin C, substantially as described.

6. In a car-coupler, the combination, with the recessed draw-head having coupling-pin openings in its upper and lower jaws, the upper opening being inclined forward on the outer side, of a pin for engaging said openings, and a swinging spring-actuated dog having its upper end pivoted within the jaws and provided on its front side with shoulders or notches for retaining the pin aforesaid in an elevated position, substantially as described, and for the purposes set forth.

7. A draw-head provided in its top side with a large opening adapted to receive a pin and a weight, also provided in its under side with an opening for the reception of the lower end of said pin, in combination with a link and a pin provided on its upper side with a weight secured thereto, the said pin being engaged in the openings aforesaid and retaining the link, the weight resting on the upper side of the link, whereby said link is retained in a horizontal position, substantially as specified.

8. A draw-head provided with recessed jaws for the reception of links, and a concave recess, *e''*, in the shank, also provided with top and bottom openings, *d* and *d'*, in combination with a link and the pin D, having the weight *d''*, substantially as specified.

In testimony whereof I affix my signature in presence of two witnesses.

JAMES J. BILLINGSLEY.

Witnesses:

H. A. BARNES,
J. W. BERRY.