

C. H. MARQUESS.  
 APPARATUS FOR MAKING CONCRETE ARTICLES.  
 APPLICATION FILED APR. 16, 1917. RENEWED AUG. 8, 1918.

Patented Oct. 15, 1918.

1,281,407.

Fig. 1.

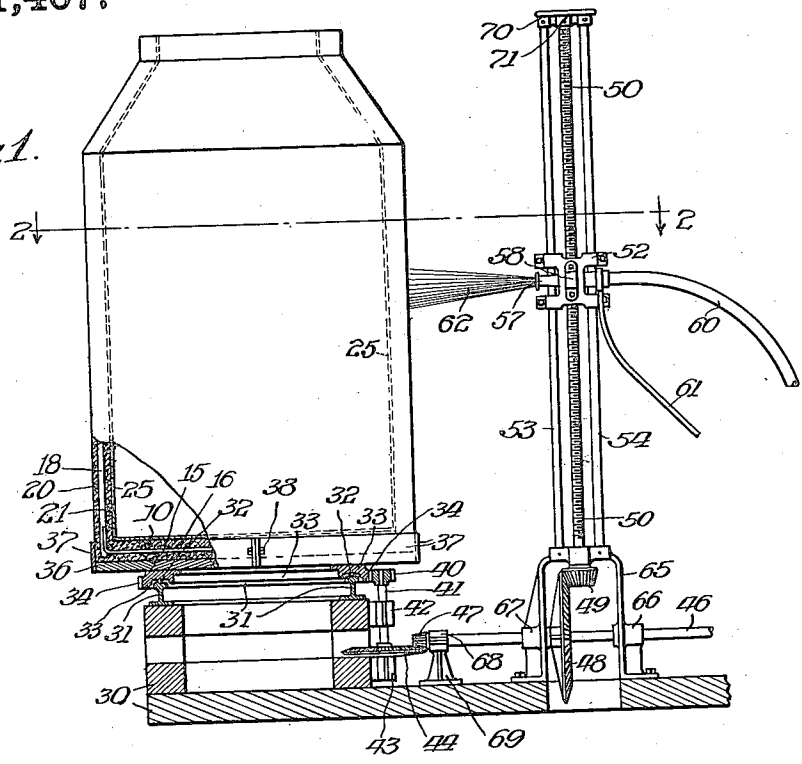
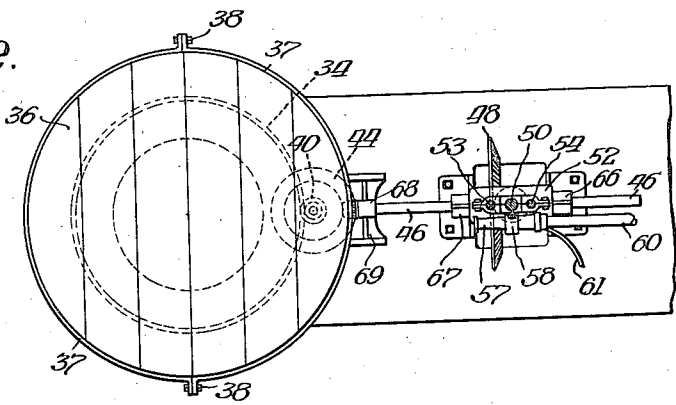

Fig. 2.



WITNESS  
*J. D. Morrison*

INVENTOR.  
*Charles Henson Marquess*  
 BY  
*Luther Jones* ATTORNEY

# UNITED STATES PATENT OFFICE.

CHARLES HENSON MARQUESS, OF MINNEAPOLIS, MINNESOTA.

## APPARATUS FOR MAKING CONCRETE ARTICLES.

1,281,407.

Specification of Letters Patent. Patented Oct. 15, 1918.

Original application filed March 8, 1917, Serial No. 153,236. Divided and this application filed April 16, 1917, Serial No. 162,302. Renewed August 8, 1918. Serial No. 248,997.

*To all whom it may concern:*

Be it known that I, CHARLES HENSON MARQUESS, a citizen of the United States, residing at Minneapolis, in the county of Hennepin and State of Minnesota, have invented certain new and useful Improvements in Apparatus for Making Concrete Articles, of which the following is a specification.

My invention relates to apparatus for making articles of concrete or of similar cementitious material. An important application of these improvements is in the construction of battery vaults and the like, and will be more specifically described and illustrated in the construction of such vaults, although the invention is not limited thereto.

Heretofore it has been common practice in the construction of battery vaults and the like to prepare molds or forms, exterior and interior, conforming to the shape of the proposed article to be manufactured, and, after locating reinforcing metal in the space between the molds, to pour such space full of the plastic or semi-liquid mortar. Inasmuch as one of the prime requisites of battery vaults is water-tightness, it has been necessary, in order to obtain even moderately satisfactory results, thoroughly to ram or puddle the mortar so as to work it around the bars and drive out, so far as possible, air which has become entrapped during the process of pouring. The density of the concrete has been contingent upon the thoroughness with which the next-above-mentioned work was done, and, since it is very difficult to work around the intricate and complicated cage of reinforcing metal with a ramming or puddling tool it frequently happens that a quite porous form of concrete results.

The most practical cementitious material for such vault construction is formed from Portland cement, sand, and water. As the plastic mass when formed begins at once to harden, and as any disturbance of the mass while it is setting results in concrete deficient in strength, it is of the greatest importance that the walls be formed with the utmost expedition. In the older methods of forming such walls a very material amount of time elapses and a great deal of disturbance of the mass takes place from the time of the addition of water to the cement and sand until the mortar is applied in final position, and it has been impossible, according to the hitherto

processes, to provide a vault of satisfactory strength and density.

Reference is directed to my co-pending application, Serial No. 153,236, filed March 8, 1917, entitled Concrete articles, of which this application is a division, and also to my co-pending application, Serial No. 162,301, filed April 16, 1917, entitled Methods of making concrete articles, wherein the present apparatus is also illustrated and described and details of specific vault construction and method of making same are more definitely set forth than will be necessary herein in view of those disclosures.

The principal object of the present improvements is to provide simple and effective means for making battery vaults, and other concrete or plastic articles of a kind suitable to be formed in connection with such apparatus, cheaply and expeditiously, while at the same time forming a structure of great density and strength. Other objects and advantages will appear hereinafter.

In the accompanying drawings which form a part of this specification, I have illustrated these improvements in simple form as employed in the art of making battery vaults and the like, Figure 1 being a side elevation of the structure, the track device and driving pinion being shown in medial vertical section, and Fig. 2 being a top plan and partly sectional view of the device of Fig. 1 as on the line 2—2 thereof, the vault of Fig. 1 being omitted in Fig. 2.

Upon a suitable support I position an annular metallic track device having an annular recess or race for a plurality of friction balls 32. A cooperating track device 33 has a similar recess or race for the balls 32, the track 33 having a gear 34 integral therewith. The track 33 is rigidly secured to the horizontal platform 36, circular in the form illustrated, and provided at its circumference with a two-piece ring of flat metal 37 clamped upon the support 36 by bolts 38 whereby this ring 37 may readily be positioned and removed. Meshing with the track gear 33 is the pinion 40, secured upon a shaft 41 rotatable in bearings 42 and 43, a bevel gear 44 being also carried by this shaft. Upon the driving shaft 46 there is a bevel pinion 47 meshing with the gear 44, and also the bevel gear 48 meshing with the pinion 49 upon the screw shaft 50. A cross-head 52

is mounted slidably upon the guides 53 and 54 and is moved in vertical directions by the screw shaft 50 in threaded engagement with the cross-head 52, as shown in Fig. 2. A nozzle 57 is secured readily removably upon the bracket 52, as by a clamping strap 58, the nozzle being directed horizontally substantially toward the axis of rotation of the base 36. To the nozzle 57 there is secured a flexible pipe 60 adapted to contain a proper mixture of cement and sand carried to the nozzle 57 by air pressure, and also the flexible pipe 61 adapted to deliver continuously to the stream of cement and sand a proper quantity of water. The guides 53 and 54 may suitably be supported upon a bracket 65 which also contains bearings 66 and 67 for the driving shaft 46, this shaft rotating also in a bearing 68 carried by the support 69. The guides 53 and 54 are also supported by a fixed piece 70 having a bearing 71 in which the screw shaft 50 rotates. The nozzle 57 and pipes 60 and 61 are elements of cement gun apparatus and are sufficiently well understood to require no detailed description here. In this connection, however, reference may be had to Patent No. 984,254 of February 14, 1911, to C. E. Akeley.

It is clear that when rotative power is applied to the shaft 46 the horizontal support 36 will be rotated upon the balls 32, and that the nozzle 57 will simultaneously be raised or lowered through the rotation of the screw shaft 50.

In forming the vault illustrated, suitable reinforcing elements for the base 10, as cross-bars 15 and 16, are preferably placed and secured so that they are temporarily held in their ultimate positions, whereupon the space inside the mortar-containing ring 37 is filled level to the top thereof with a mixture of cement, sand and water (or other cementitious material), either by filling in by hand in the ordinary way or by means of the nozzle 57, which may readily be detached from the crosshead 52 for spraying the mixture over the platform by hand.

After the base 10 is formed, the inner lining, form or core 25 is positioned directly on top of the base and is carefully centered so as to make its axis coincide with the axis of rotation of the base 10. The steel or iron reinforcing parts consisting of the bars 18, 20 and 21 secured together so as to form a rigid frame-work, is placed around the lining, form or core 25, the lower ends of the bars 18 being pressed downward into the soft mortar of the bottom wall or base 10. The form, core or lining 25 may be secured to the metallic framework, as by wiring, if it is of such thin material as to require it, but, if of relatively stiff material, such as roofing felt or fiber, as soon as the frame-work is thus positioned and suitably adjusted as to its desired concentric arrangement with the

core the operation of applying the cementitious material may be begun. Other kinds of cores or forms against which the material is to be projected may be employed.

The cement and sand forced through the pipe 60 by air pressure at a high rate of travel unites with a suitable supply of water from the pipe 61 and the plastic cement issues from the nozzle in the form of a jet 62 which impinges upon the core or form 25, adhering to it and finally covering the metallic frame-work. The operation is begun preferably by directing the jet 62 against the lining 25 at the bottom of the side wall thereof, or close to the ring 37, the base, core and frame-work rotating the while. The cementitious material is thus applied progressively and evenly over the parts designed to be covered, the nozzle 57 regularly traveling upward during the operation.

A vault or other structure thus formed is exceedingly strong and compact, the concrete being free from air bubbles or other voids and having been applied without appreciable loss of time while setting was under way and without any disturbance of the applied particles or mass.

While it is possible so to proportion the rates of rotation of the support 36 and the travel of the nozzle 57 that the desired thickness of cement can be applied in a single coat, ordinarily I prefer to make the coats less thick and apply two or more thereof to obtain the desired thickness. After forming the walls the material is allowed to harden, after which the article can readily be removed from the horizontal support 36, it being preferable first to remove the ring 37.

A feature of advantage resides in the fact that a plurality of such apparatuses for forming such articles may be operated by a limited number of workmen in the simultaneous construction of a considerable number of the articles being made, thus greatly reducing the time and cost of the output.

Numerous modifications may be made of the apparatus illustrated and described without departing from the spirit of the present invention, and I contemplate all such changes as come within the scope of the appended claims.

I claim:

1. A mechanism for forming articles of cementitious material comprising in combination a horizontal support mounted to rotate on a vertical axis, a nozzle adjacent to said support and adapted to discharge cementitious material substantially toward the axis of rotation thereof, means for rotating said support, and means for simultaneously moving said nozzle progressively in a direction substantially parallel with the axis of rotation of said support.

2. A mechanism for forming articles of cementitious material comprising in combi-

5 nation, a horizontal platform, an annular track horizontally disposed carried by said platform, a second annular track opposing said first mentioned track, rolling devices  
10 between said tracks, a nozzle mounted to move in a substantially vertical direction adjacent to said platform, means for so moving said nozzle, means for conveying cementitious material under pressure to said nozzle, and means for rotating said platform on said rolling devices.

3. A mechanism for forming articles of cementitious material comprising in combi-

nation, a horizontal platform, means for rotating said platform on a substantially vertical axis, a nozzle adjacent to said platform and directed substantially toward the axis of rotation thereof, a guide substantially vertically disposed, a movable member slidably mounted on said guide, said nozzle being carried by said movable member, means including a rotatable screw shaft substantially parallel with said guide for moving said nozzle, and means for rotating said screw shaft.

CHARLES HENSON MARQUESS.