

M. HOGAN.
Water-Closet.

No. 203,045.

Patented April 30, 1878.

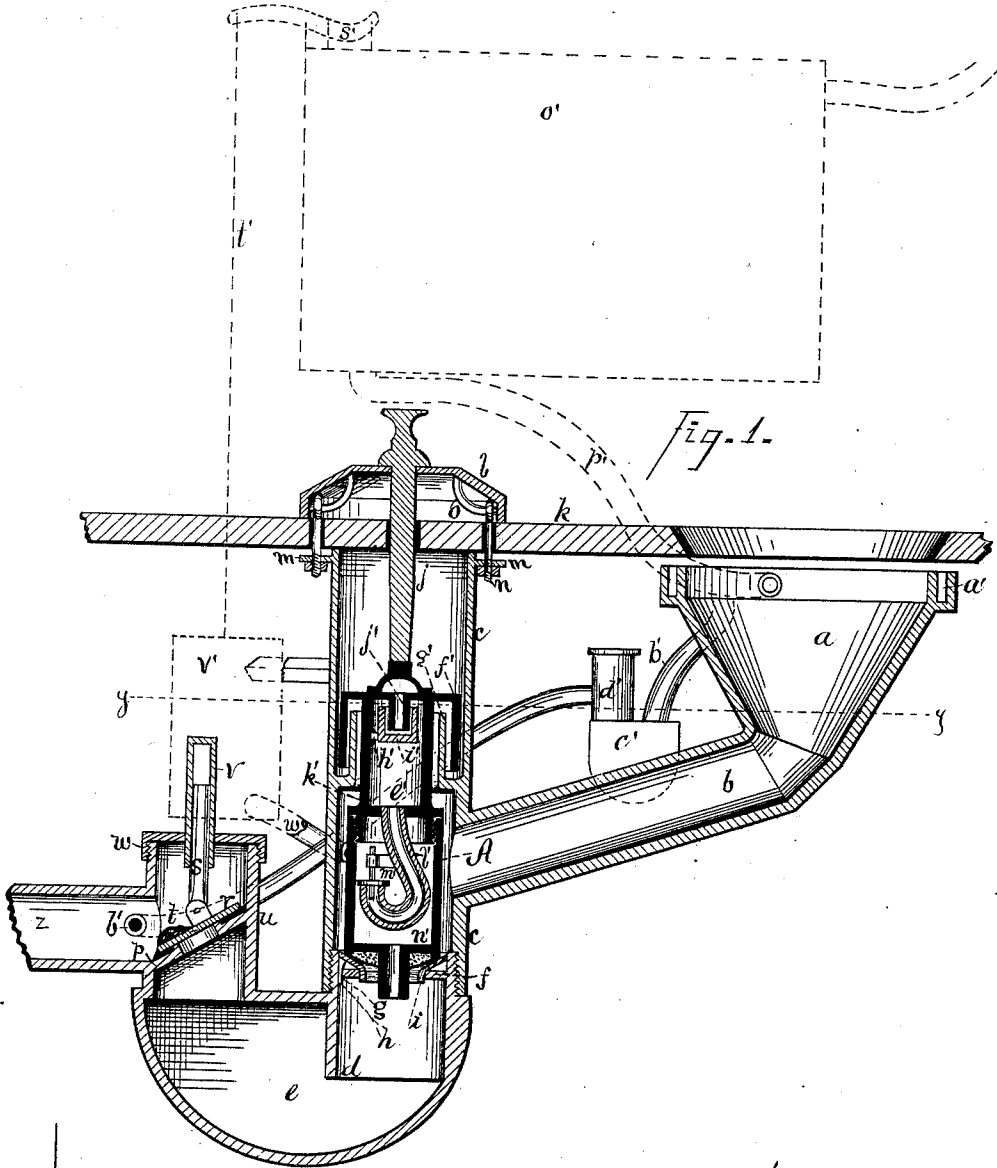

Witnesses:
Robt J. Gayford
M. F. Dooley

Inventor:
M Hogan,
By W. E. Simonds
Atty

M. HOGAN.
Water-Closet.

No. 203,045.

Patented April 30, 1878.

Fig. 2.

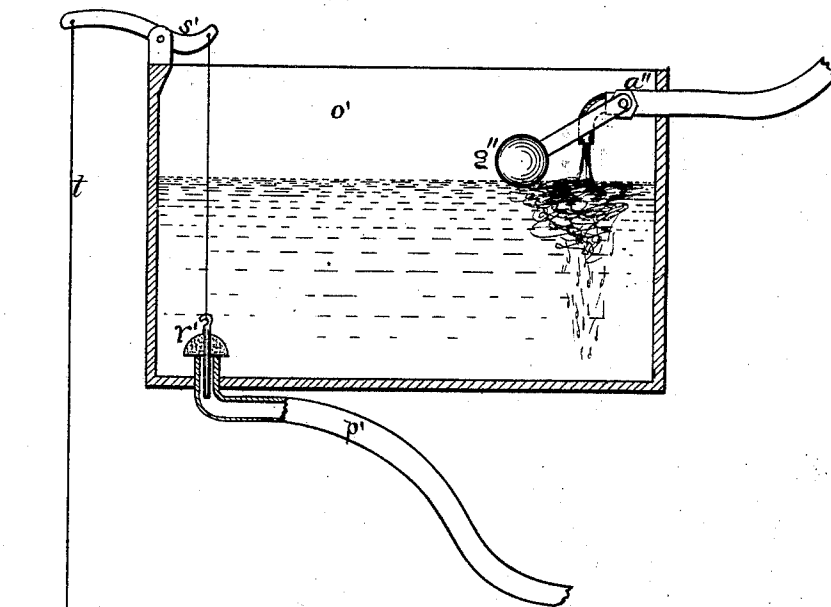
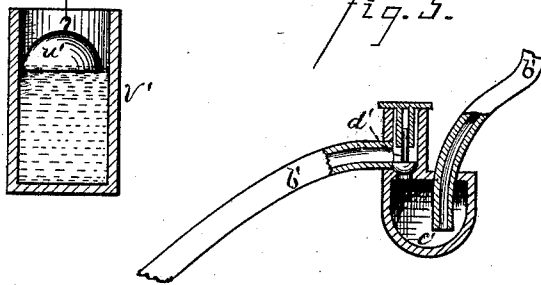

Fig. 3.



Witnesses:

Robt. J. Gayford
M. F. Dooly

Inventor:

M. Hogan
By W. E. Simms
att'y

M. HOGAN.
Water-Closet.

No. 203,045.

Patented April 30, 1878.

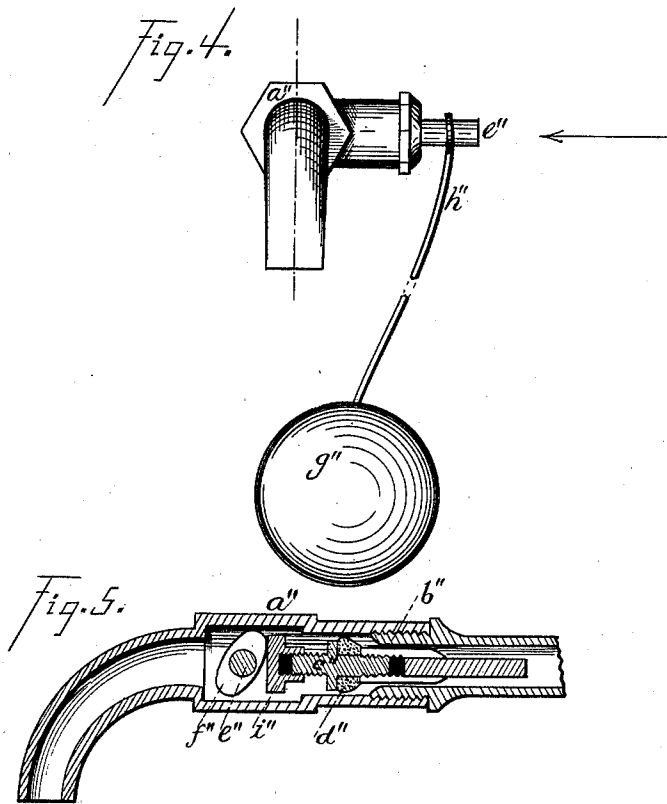

Witnesses:
Robt J. Gaylord
A. D. Akeley

Inventor:
M. Hogan
by W. E. Simard
Atty.

UNITED STATES PATENT OFFICE.

MATTHEW HOGAN, OF HARTFORD, CONNECTICUT.

IMPROVEMENT IN WATER-CLOSETS.

Specification forming part of Letters Patent No. **203,045**, dated April 30, 1878; application filed April 15, 1878.

To all whom it may concern:

Be it known that I, MATTHEW HOGAN, of Hartford, in the county of Hartford and State of Connecticut, have invented certain new and useful Improvements pertaining to a Water-Closet, of which the following is a specification, reference being had to the accompanying drawings, where—

Figure 1 is a sectional elevation, showing the basin, main valve, and main trap in central vertical section. Fig. 2 is a sectional elevation, showing the open tank, its valve, and the float for operating the valve, and the intermediate parts in central vertical section. Fig. 3 is a detached vertical sectional view of the trap in the waste-pipe leading from the overflow-receiver which surrounds the basin. Fig. 4 is an end view, and Fig. 5 is a view in central longitudinal section, of the faucet or cock which supplies the tank.

The letter *a* denotes the bowl or receiving-basin of a water-closet; *b*, a water-way leading therefrom to the stand-pipe *c*.

The letter *d* denotes a short pipe or collar rising from the top of the trap *e*, on which fits and fastens, by screwing or otherwise, the stand-pipe *c*. The collar *d* contains an internal annular flange, *f*, pierced by orifices *g* for the reception of the teats *h* projecting downwardly from the valve-seat *i*. This valve-seat is preferably of non-corrosive metal, and by the arrangement described is readily removable.

The valve, as a whole, I will designate by the letter *A*. Its component parts I will describe hereinafter. The valve *A* is operated by means of the valve-rod *j*, which extends up through the slab or seat *k*, and through the cap *l*. The top of the stand-pipe *c* is furnished with the ears *m*, pierced for the passage of the bolt-rods *n*, which, coming down from the cap through the slab *k* and through the ears *m*, have nuts underneath the ears, and these nuts, when screwed up against the ears, serve to connect the cap *l* and stand-pipe *c* to the slab *k*. These bolt-rods *n*, instead of coming down rigidly from the cap *l*, are hung on traverse-loops *o*, attached to the under side of the cap *l*. This arrangement is for the purpose of allowing the bolt-rods to fit to the position of the holes which are drilled in the slab for their

passage. When these bolt-rods are rigid on the cap *l*, it not unfrequently happens that the holes for their passage through the slab are wrongly drilled, and trouble results.

The trap *e* has an outlet-valve as well as an inlet-valve. The letter *p* denotes the seat thereof, and *r* the valve, which is jointed to the valve-rod *s*, and preferably is weighted on one side by the weight *t*. This outlet-valve is located in the stand-pipe *u*, which is located on top of the trap *e*. The valve-rod *s* has up-and-down play in the guide-tube *v*, which is held fast in the cap *w* of the stand-pipe *u*. The letter *z* denotes the outlet from the stand-pipe *u*.

The bowl or basin *a* is surrounded by the overflow-receiver *a'*, to receive accidental overflow. This receiver is provided with the waste-pipe *b'*, leading to the main waste-pipe *z*. This waste-pipe *b'* is furnished with a trap, *c'*, having an outlet-valve, *d'*, closing against backward pressure, as does the main outlet-valve *r*.

I will now describe the main valve *A*. The letter *e'* denotes the barrel or body thereof, furnished at the top with the return-flange *f'*, dipping into the cup-flange *g'*, attached to the interior of the stand-pipe *c*.

When the water-closet is quiet the water stands about as represented by the dotted line *y*, and when the valve *A* is raised it is never raised so far that the flange *f'* leaves the water, so that the trap formed by the flanges *f'* *g'* is always sealed, whether the valve *A* be open or closed. Within the barrel *e'*, and supported from it by supports *h'*, is the cup-flange *i'*. The top of the barrel *e'* bears at the top the return-flange *j'*, dipping into the cup-flange *i'*. If, by mischance, the water rises too high in the bowl *a*, it flows up over the top of the valve *A*, thence down into the cup *i'*, and escapes over its edge down below.

It will be observed that the flanges *i'* *j'* form a trap. But the valve *A* is furnished with still another trap, which closes by backward pressure, the same as the valves *r* *d'*, so that the whole device is protected by positive valves against the pressure of sewer-gases, &c. The water coming from the cup *i'* falls down into the chamber *k'*, whence it must pass out through the trap *b'* furnished with the valve *m'*, which closes against back pressure of gases. This trap *b'* is contained within the casing *n'*,

which is properly shaped and located to shut down on the valve-seat *i*. The water which passes down through the trap *l'* falls into the main trap *e*.

I will now describe the means through or by which water is fed to the closet from an open tank, which tank, by my method, can be located at a distance from the closet or in another room. The letter *o'* denotes the open tank; *p'*, the supply-pipe leading therefrom to the bowl *a*; *r'*, the valve opening into the supply-pipe depending from the lever *s'*, from which the pull-wire *t'* runs to the float-valve *u'* contained in the pipe or reservoir *v'*, which, by pipe *w'*, communicates with the stand-pipe *c*, so that the water in pipe *v'* stands at the same height that it does in the bowl *a* and stand-pipe *c*. When the closet is at rest the height of the water in pipe *v'* is such as to cause the valve *r'* to remain closed; but when the main valve *A* is opened the float *u'* will fall with the fall of the water, and open the valve *r'*, and send a fresh supply of water to the bowl *a*. When the main valve *A* is dropped to its seat the water will gradually rise in pipe *v'*, and so close the valve *r'*. This gradual rise of the float *u'* gives the requisite after-wash in the bowl *a*.

I will now describe the faucet or cock which supplies the tank *o'*. The letter *a''* denotes the body or barrel of the faucet; *b''*, the valve-seat screwing into the body *a''*; *c''*, the valve-rod bearing the valve *d''*, which in closing moves against the current of inflowing water. On the rotary shaft *e''* is a double cam, *f''*, acting in some positions to close the valve, and in others to allow it to open. The ball (a float) *g''* on the arm *h''*, attached to the outer

end of the shaft *e''*, gives the requisite movements to the shaft. The head or inner end *i''* of the valve-rod screws upon the valve-rod, so that as the cam *f''* or this head wears away by use this head can be adjusted to compensate for such wear.

I claim as my invention—

1. The pipe *d*, provided with the perforated flange *f*, in combination with the valve-seat *i*, provided with the teats *h*.
2. The trap *e*, in combination with the valve *r*, pivoted to the valve-rod *s*.
3. The cap *l*, provided with the traverse-loops *o*, in combination with the bolt-rods *n*.
4. In combination, the overflow-receiver *a'*, waste-pipe *b'*, and trap *c'*, provided with the valve *d'*.
5. In combination, the pipe *c*, provided with the cup-flange *g'*, the valve-barrel *e'*, provided with the return-flanges *f' j'*, and the cup *i'*.
6. In combination, the valve *A* and the valved trap *l'* contained in or carried on the valve *A*.
7. In combination, the basin *a*, stand-pipe *c*, valve *A*, open tank *o'*, supply-pipe *p'*, valve *r'*, lever *s'*, rod *t*, float *u'*, pipe *v'*, and pipe *w'*.
8. In combination, the barrel of faucet *a''*, the valve-seat *b''*, the valve-rod *c''*, provided with the valve *d''*, and the shaft *e''*, provided with the cam *f''*.
9. In combination, the faucet-barrel *a''*, valve-seat *b''*, valve-rod *c''*, provided with the valve *d''* and adjustable head *i''*, and the shaft *e''*, provided with the cam *f''*.

MATTHEW HOGAN.

Witnesses:

WM. E. SIMONDS,
ROBT. F. GAYLORD.