



US 20050145535A1

(19) **United States**

(12) **Patent Application Publication**

**Augborne**

(10) **Pub. No.: US 2005/0145535 A1**

(43) **Pub. Date:**

**Jul. 7, 2005**

(54) **TOY VEHICLE DISPLAY PACKAGE**

(52) **U.S. Cl.** ..... 206/736; 206/756; 206/769

(76) **Inventor: Troy Augborne, Whittier, CA (US)**

(57) **ABSTRACT**

Correspondence Address:

**Roy A. Ekstrand**

**Mattel, Inc MI-1518**

**333 Continental Blvd**

**El Segundo, CA 90245 (US)**

A toy vehicle package includes a generally cylindrical body having a removable base on the lower end thereof and a removable cap on the upper end thereof. The base includes a vehicle platform which receives and supports a toy vehicle. The package body defines a transparent window through which the toy vehicle may be viewed. A plurality of removable breakaway tabs extend downwardly from the toy vehicle package body through slots defined in the base to provide attachment of the base. Once the tabs have been removed, the base is then rotateably positionable within the toy vehicle package body.

(21) **Appl. No.:** 10/750,745

(22) **Filed:** Jan. 2, 2004

**Publication Classification**

(51) **Int. Cl.<sup>7</sup>** ..... B65D 5/50

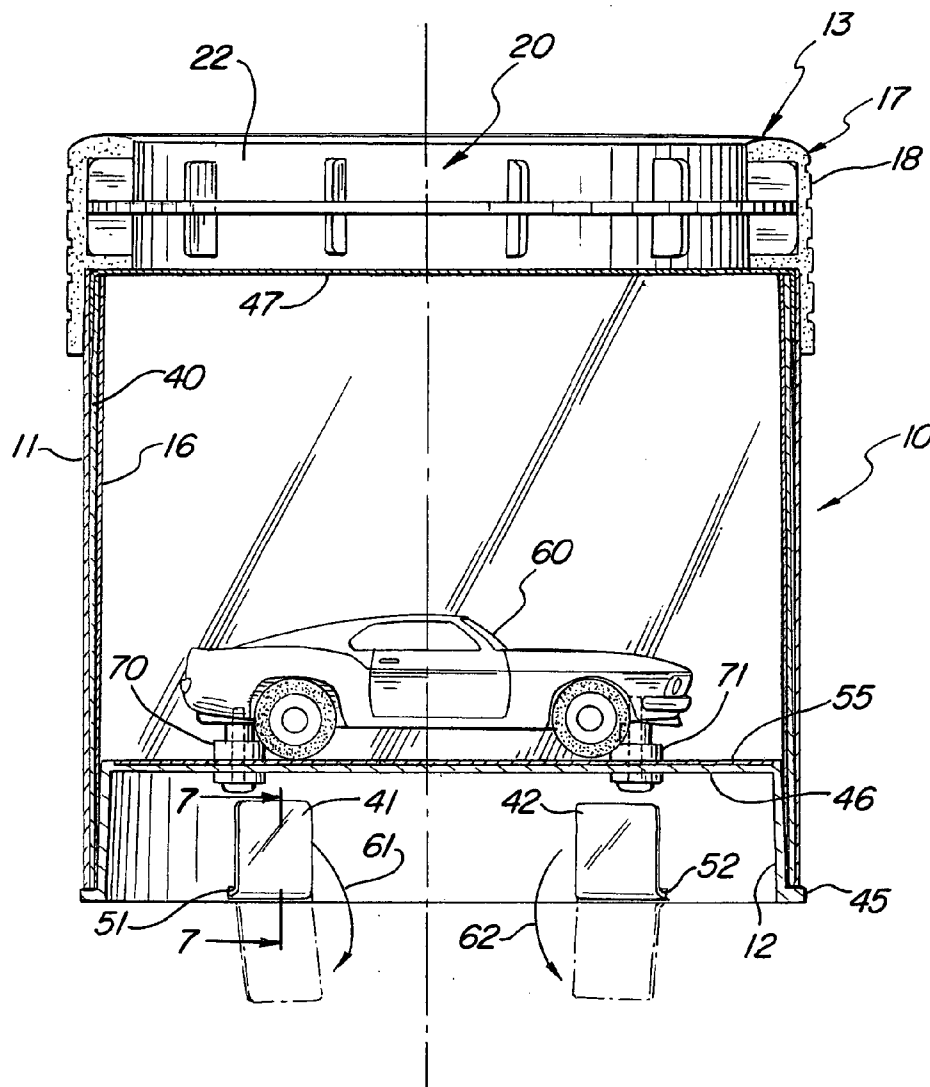

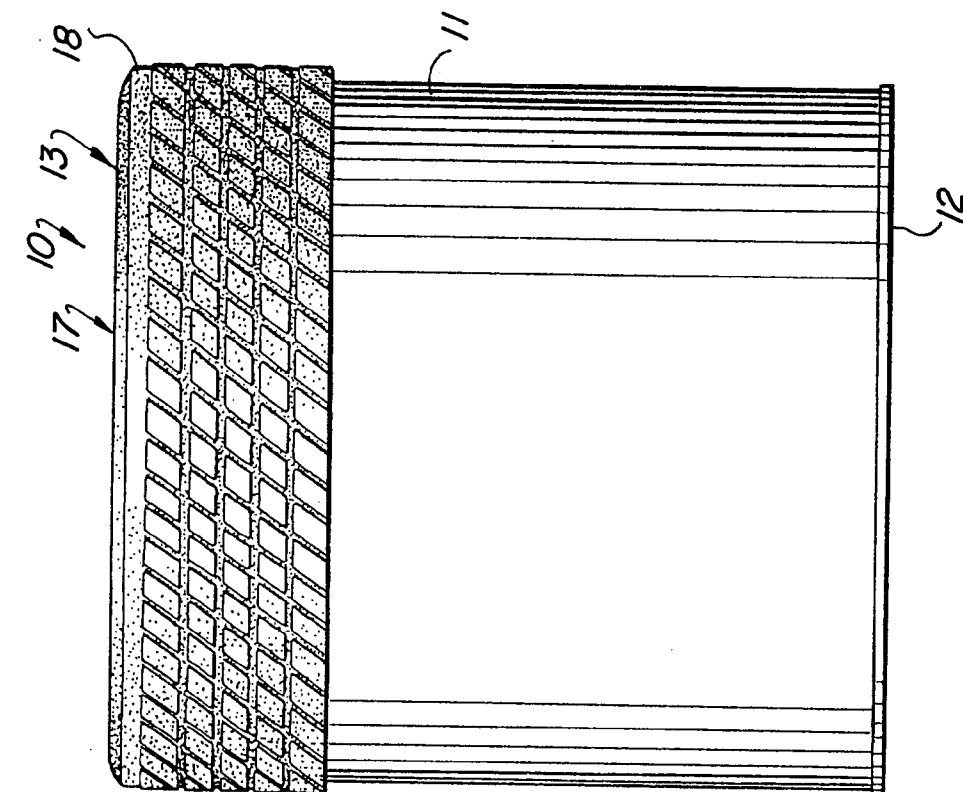

FIG. 2

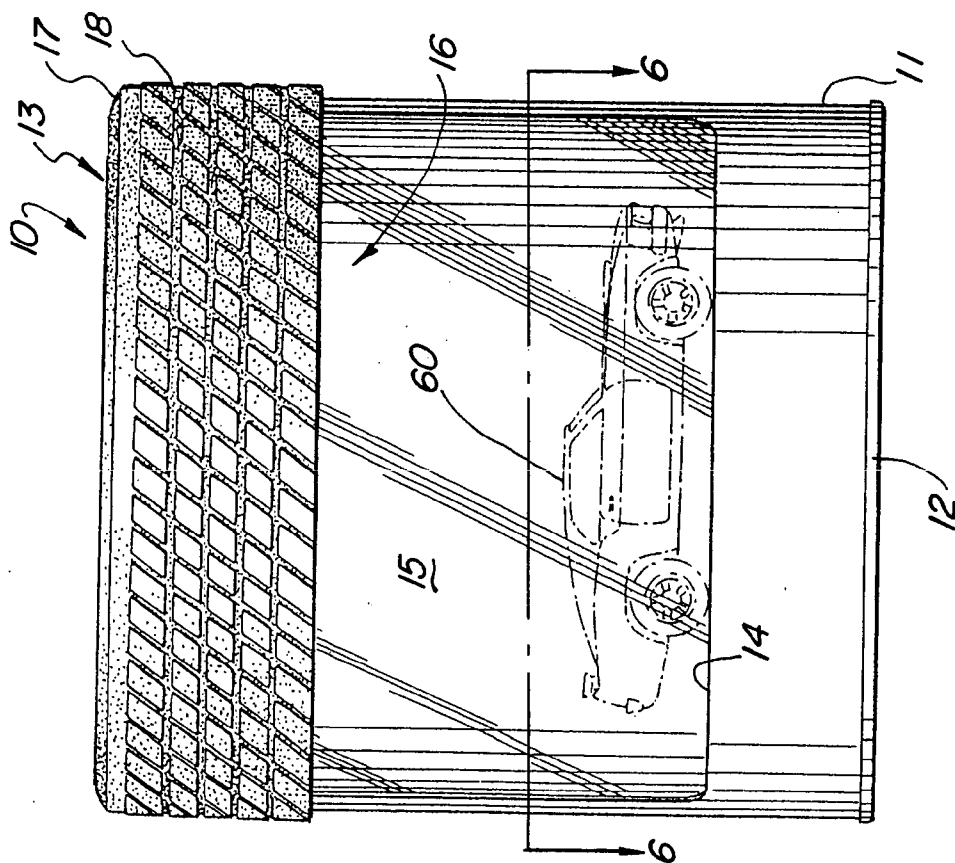

FIG. 1

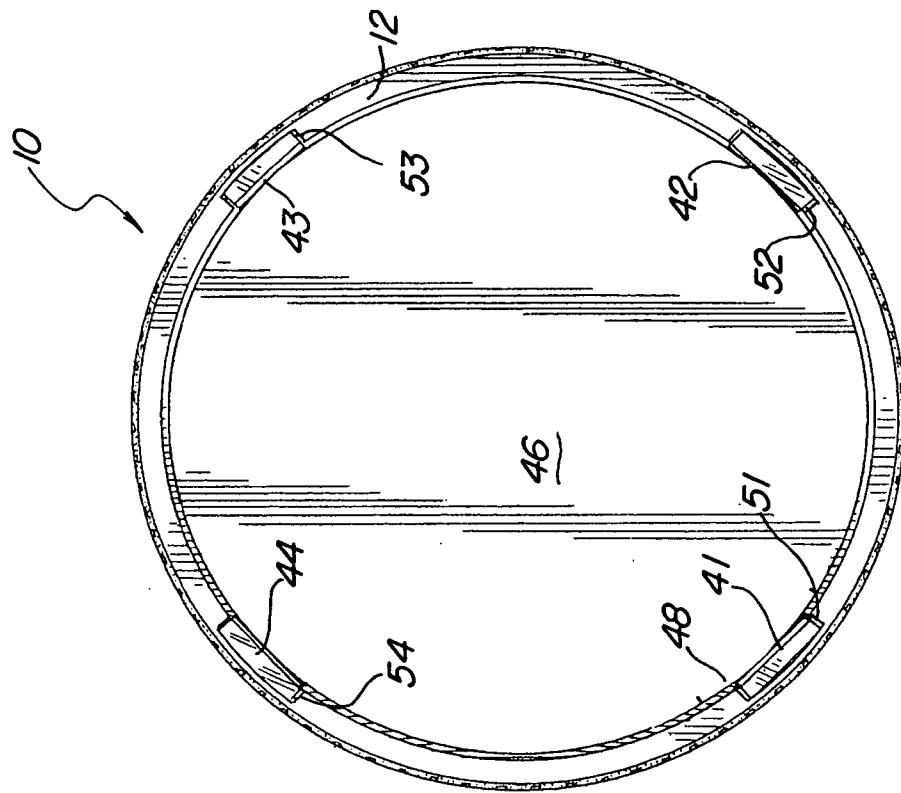

FIG. 4

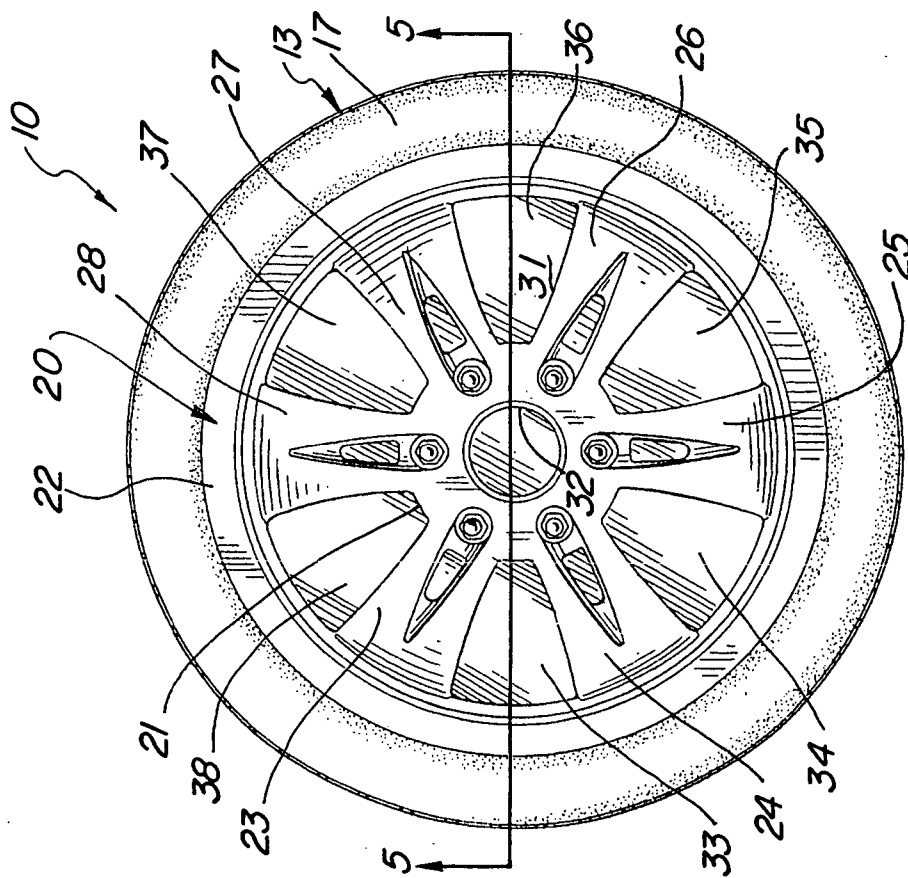

FIG. 3

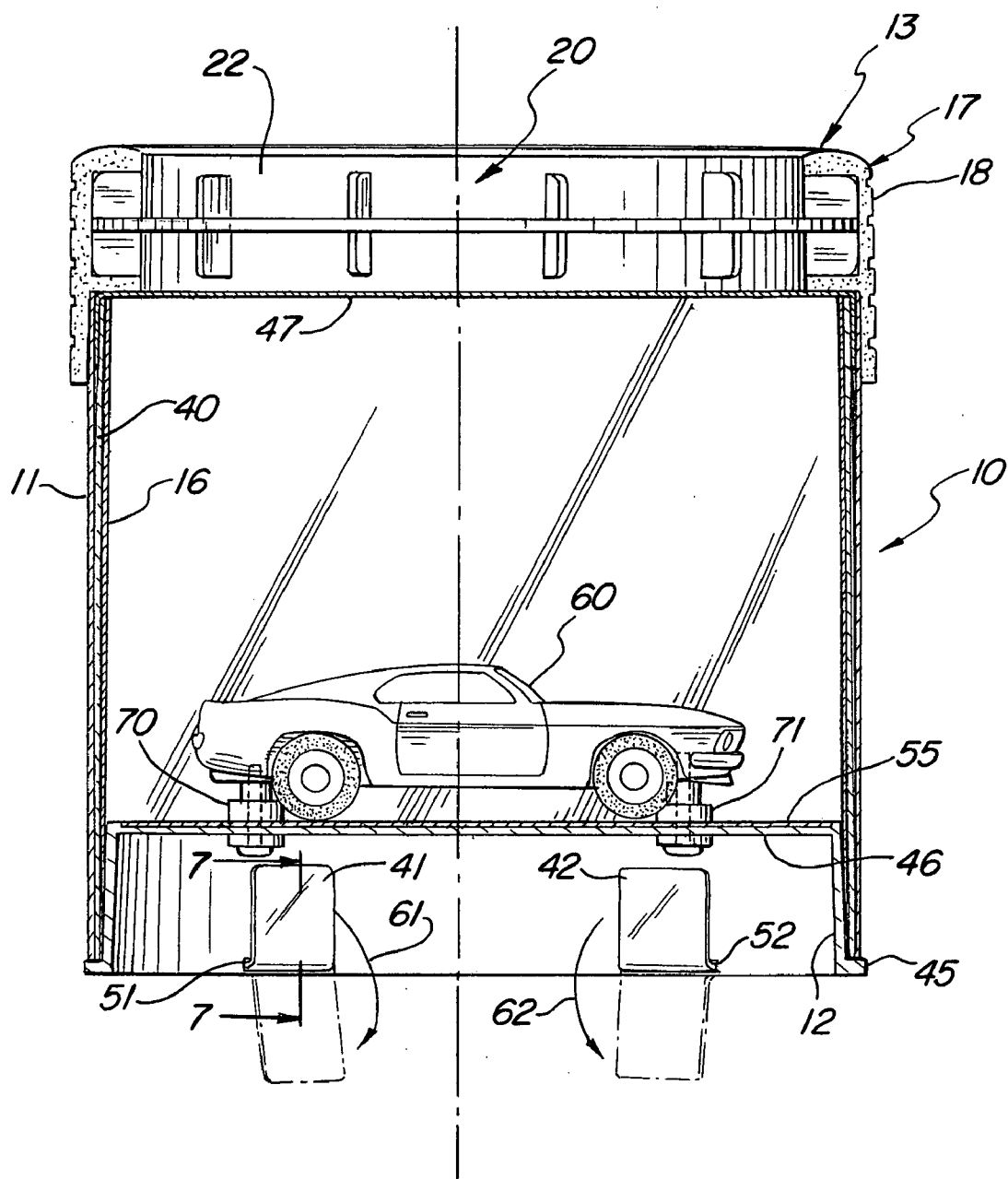

FIG. 5

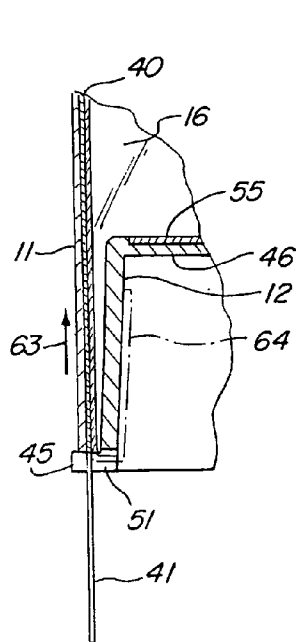

FIG. 7

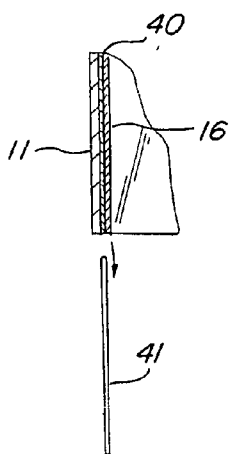

FIG. 8

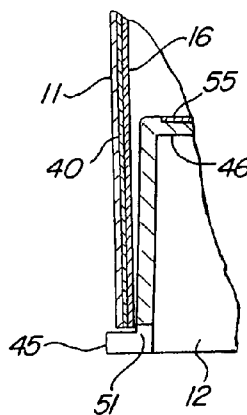

FIG. 9

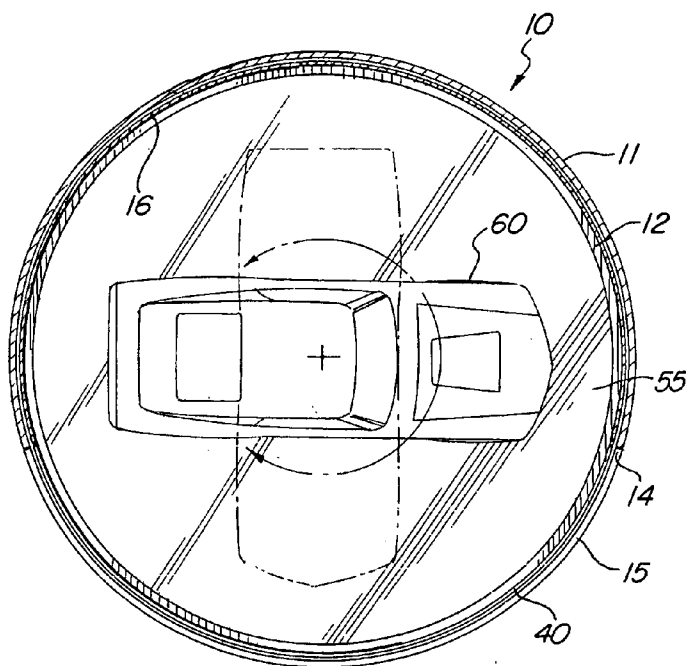

FIG. 6

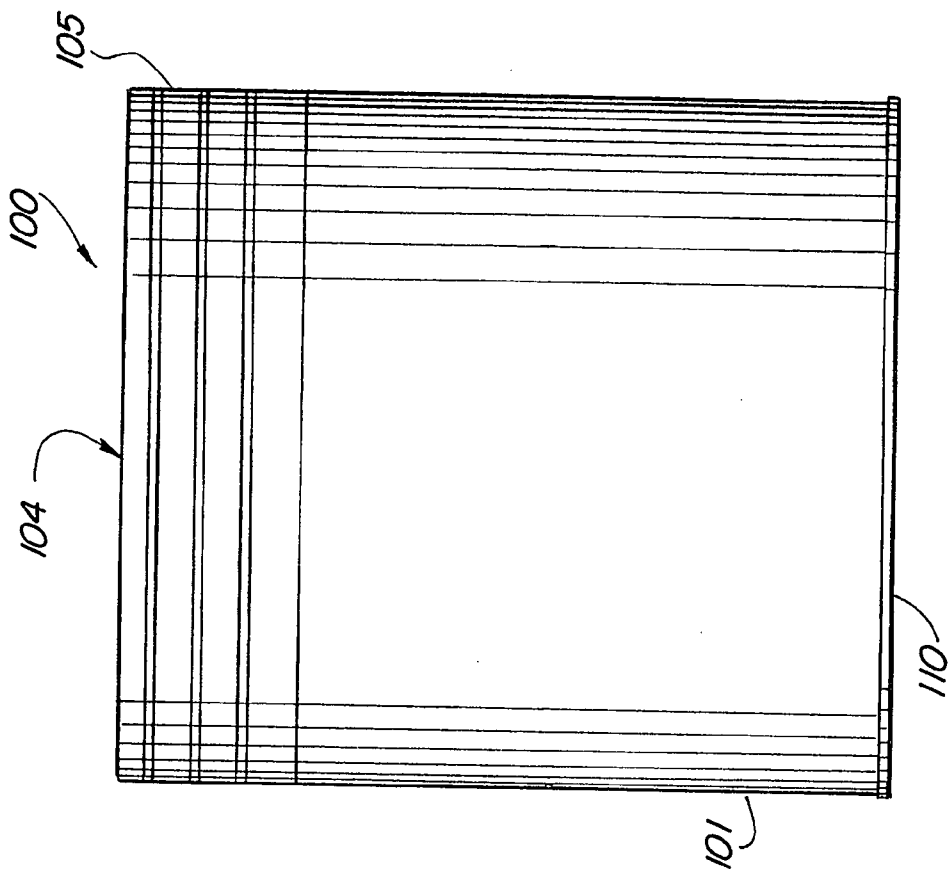

FIG. 11

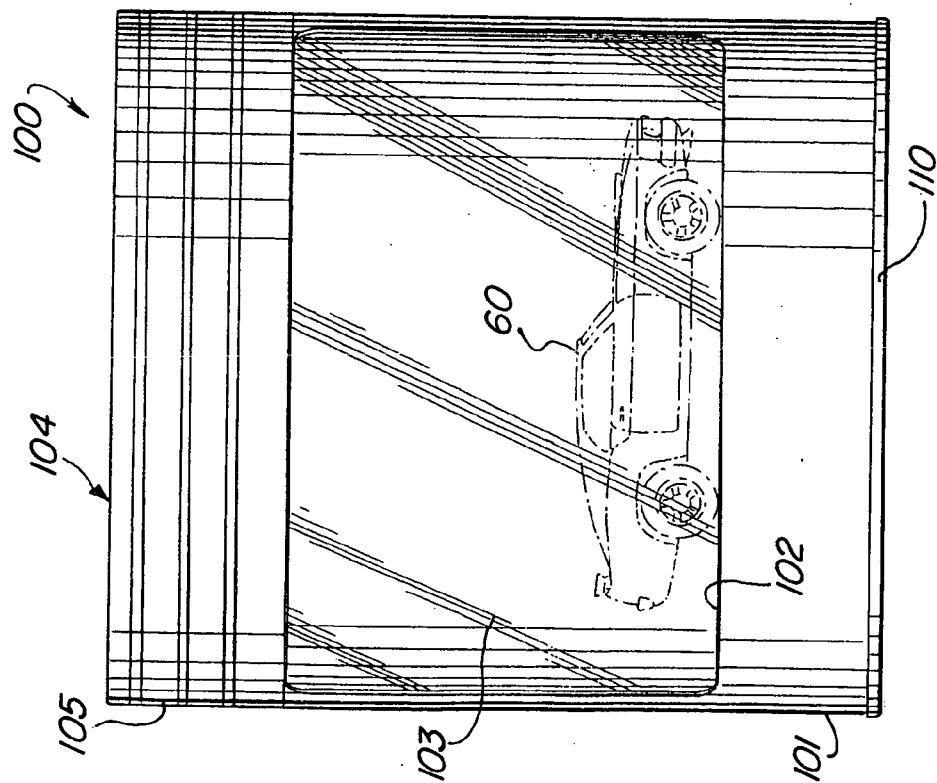

FIG. 10

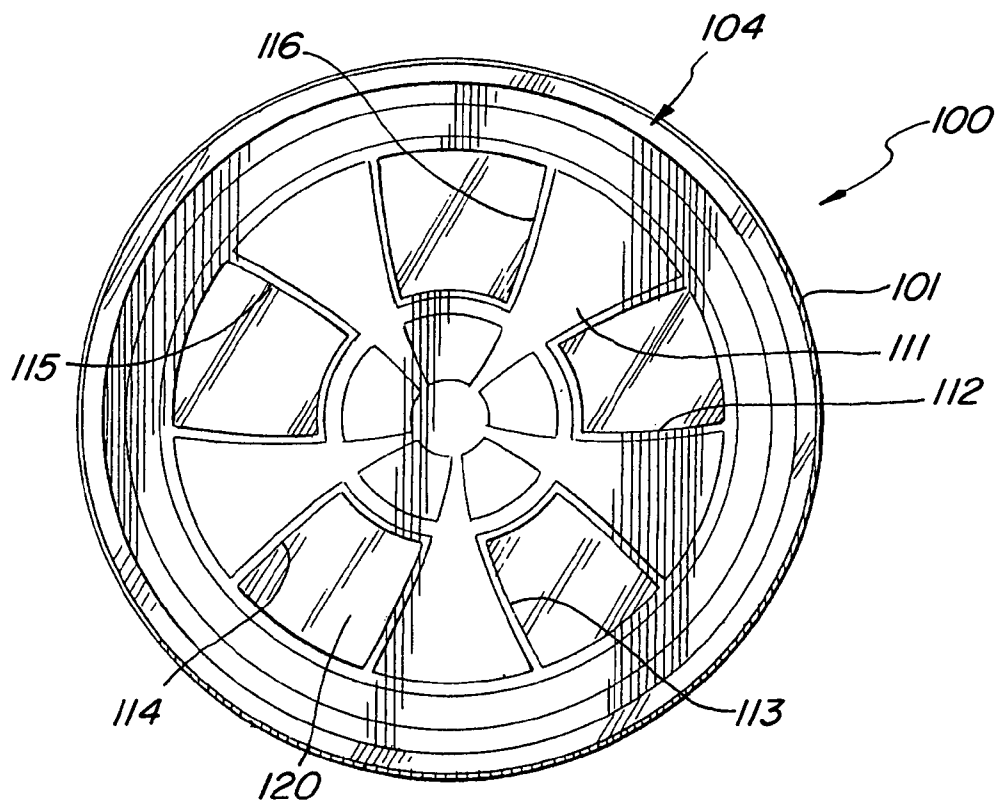

FIG. 12

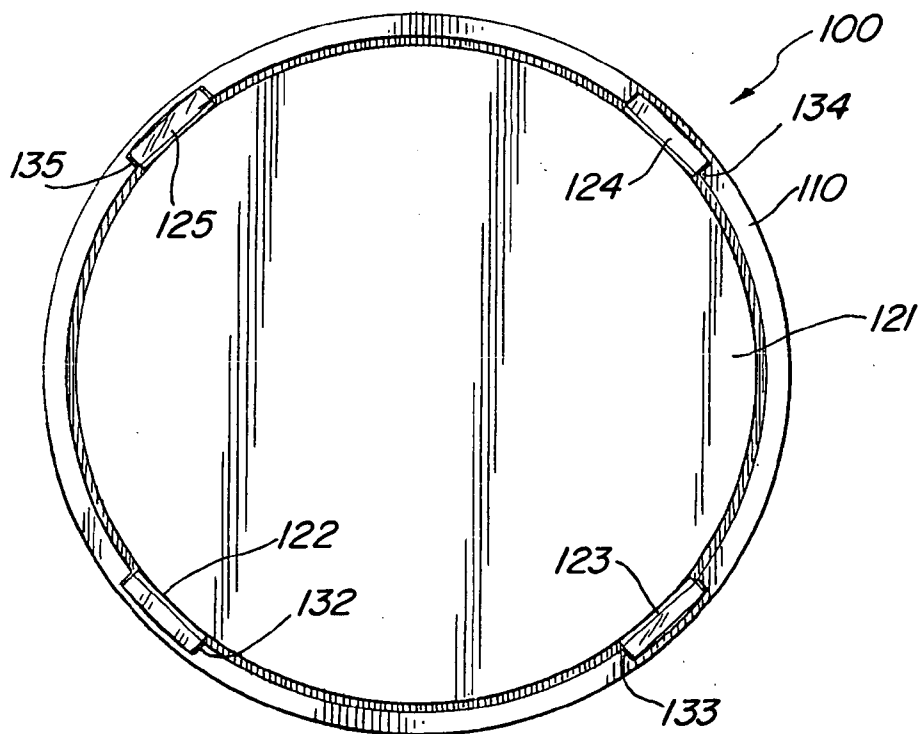

FIG. 13

**TOY VEHICLE DISPLAY PACKAGE**

**FIELD OF THE INVENTION**

[0001] This invention relates generally to toy products and particularly to packaging design for use therewith.

**BACKGROUND OF THE INVENTION**

[0002] Toy vehicles comprise a well-known and long-lasting species of toys. As such, toy vehicles have proven to be extremely popular and have survived for a great number of years among consumers. Not surprisingly, practitioners in the toy arts have responded to this continuing need and popularity by providing a substantially endless variety of toy vehicle types and sizes.

[0003] Thus, toy vehicles have been provided which have varied from simple low-cost passive toy vehicles to highly detailed expensive and complex designs. Many toy vehicles are provided with a self contained power source such as a battery driven electric motor and gear mechanism while others are unpowered and are basically free-wheeling. Many toy vehicles are fabricated with sufficient creativity and detail in appearance that they are more like vehicle models than toy intended to be used in every day play. Such toy vehicles have proven to be “collectible” in nature and use. Collectible toy vehicles are often organized into various series or groups allowing collectors to accumulate a given class of collectible toy vehicles. Many collectors employ relatively elaborate design cases for maintaining, protecting and displaying their collected toy vehicles.

[0004] In a some what related segment of the toy vehicle industry, toy vehicles have been provided which are highly detailed and visually creative while still being manufactured at a sufficiently low-cost to allow their use as toys to be played with. Such vehicles are often sought for both play and collection and are accumulated as “quasi art objects” and thus are often displayed as collections or arrangements of playable toy vehicles.

[0005] Recognizing this latter toy vehicle market segment, practitioners in the toy art have endeavored in many instances to provide product packaging which functions to attract and amuse potential purchasers while simultaneously providing somewhat of a display case for one or more toy vehicles. Despite substantial efforts by practitioners in achieving such dual use packaging, there remains nonetheless a continuing need in the art for evermore improved, interesting low-cost toy vehicle packaging systems which meet basic security and protection requirements of toy vehicles while simultaneously providing adequate and interesting display features.

**SUMMARY OF THE INVENTION**

[0006] Accordingly, it is a general object of the present invention to provide an improved toy vehicle display package. It is a still more particular object of the present invention to provide an improved toy vehicle display package which maintains toy vehicle security during shipment and storage while simultaneously providing display features in a useable display package.

[0007] In accordance with the present invention, there is provided a toy vehicle display package comprising: a generally cylindrical body defining a window aperture, a top and

a bottom; a base receivable within the bottom of the body and defining a plurality of slots and a vehicle support platform; a cap received upon the top of the body; and a plurality of tabs supported by the body and extending through the slots the tabs bending to secure the base to the body, the tabs also being removable.

**BRIEF DESCRIPTION OF THE DRAWINGS**

[0008] The features of the present invention, which are believed to be novel, are set forth with particularity in the appended claims. The invention, together with further objects and advantages thereof, may best be understood by reference to the following description taken in conjunction with the accompanying drawings, in the several figures of which like reference numerals identify like elements and in which:

[0009] **FIG. 1** sets forth a front view of a toy vehicle display package constructed in accordance with the present invention;

[0010] **FIG. 2** sets forth a rear view of the present invention toy vehicle display package;

[0011] **FIG. 3** sets forth a top view of the present invention toy vehicle display package.

[0012] **FIG. 4** sets forth a bottom view of the present invention toy vehicle display package;

[0013] **FIG. 5** sets forth a section view of the present invention toy vehicle display package taken along section lines 5-5 in **FIG. 3**;

[0014] **FIG. 6** sets forth a top section view of the present invention toy vehicle display package taken along section lines 6-6 in **FIG. 1**;

[0015] **FIG. 7** sets forth a partial section view of the package locking tab mechanism of the present invention toy vehicle display package;

[0016] **FIG. 8** sets forth a partial section view of the locking tab removal of the present invention toy vehicle display package;

[0017] **FIG. 9** sets forth a partial section view of the present invention toy vehicle display package having a locking tab removed;

[0018] **FIG. 10** sets forth a front view of an alternate embodiment of the present invention toy vehicle display package;

[0019] **FIG. 11** sets forth a rear view of the alternate embodiment of the present invention toy vehicle display package shown in Figure;

[0020] **FIG. 12** sets forth a top view of the alternate embodiment of the present invention toy vehicle display package shown in **FIG. 10**;

[0021] **FIG. 13** sets forth a bottom view of the alternate embodiment of the present invention toy vehicle display package shown in **FIG. 10**.

**DESCRIPTION OF THE PREFERRED EMBODIMENTS**

[0022] **FIG. 1** sets forth a front view of a toy vehicle display package constructed in accordance with the present



invention and generally referenced by numeral 10. By way of overview, package 10 defines a generally cylindrical shaped package within which a toy vehicle 60 is secured and displayed. Package 10 further includes a realistic cap 16 which is configured to resemble a racing tire and racing type rim or wheel.

[0023] More specifically, package 10 includes a cylindrical body 11 having a base 12 on the bottom portion thereof. A cap 13 is received upon the upper portion of body 11 and secured thereto by a tight-fit slip-on attachment. Cap 13 is fabricated to provide a simulated rubber tire 17 having a simulated tread 18 formed thereon.

[0024] In accordance with the preferred fabrication of the present invention, body 11 which is made of an opaque material such as cardboard or particle board of the like defines a large window aperture 14 which supports a transparent plastic cover 15. As is better seen below in FIG. 5, toy vehicle 60 is secured to a support platform 46 which in turn is supported by base 12. In further accordance with the present invention, a rear mirror 16 is supported upon the interior of package 10 and generally covers the rear portion of package 10 which is viewable through window aperture 14 and transparent cover 15. The presence of mirror 16 behind vehicle 60 provides an amusing multiple view reflection of toy vehicle 60 and cooperates with the utilization of base 12 described below to selectively position toy vehicle 60 within package 10.

[0025] FIG. 2 sets forth a rear view of package 10 which, as described above, includes a generally cylindrical preferably opaque body 11 and a supporting base 12. As is also described above, package 10 includes a cap 13 is formed to provide a simulated rubber tire 17 having a simulated tread 18 formed thereon.

[0026] FIG. 3 sets forth a top view of package 10 having cap 13 received upon body 11 in the configuration shown in FIGS. 1 and 2. In accordance with the preferred appearance of cap 13, a simulated rubber tire 17 preferably fabricated of a rubber or plastic material supports a simulated tire tread 18 along its horizontal surface. Continuing with the wheel and tire simulation of cap 13, cap 13 includes a simulated performance wheel 20 preferably fabricated of a molded plastic or metal material and preferably exhibiting a color and finish corresponding to an aluminum or alloy wheel typical of high performance vehicles. Accordingly, simulated wheel 20 includes a rim 22 which is received upon simulated rubber tire 17. Simulated wheel 20 further includes a center hub 21 defining a center aperture 32. A plurality of radially extending wheel spokes 23, 24, 25, 26, 27 and 28 extend outwardly from hub 21 and are integrally formed with rim 22. The radial arrangement of spokes 23 through 28 extending from hub 21 creates a plurality of corresponding spaces or openings 33 through 38 between adjacent pairs of spokes. This raised spoke construction which produces spaces or openings 33 through 38 adds substantial realism to the simulation of wheel 20 and tire 17 to form an interesting and amusing cap 13.

[0027] To preserve the integrity of package 10, a transparent cover 31 extends beneath simulated wheel 20 to provide closure of the package while facilitating viewing of the contents therein.

[0028] FIG. 4 sets forth a bottom view of package 10 showing the interlocking mechanism by which base 12 is

secured to body 11. In the preferred fabrication of the present invention, a plurality of slots 51, 52, 53 and 54 are formed in base 12 in a substantially equal space arrangement about the interior of the bottom portion of body 11. Correspondingly, by means set forth below in greater detail, a plurality of break away tabs 41, 42, 43 and 44 extend through slots 51 through 54 respectively and are bent inwardly to captivate the interior surface of base 12 and provide locking closure of package 10. The closure of locking tabs 41 through 44 may be supplemented by a quantity of conventional adhesive tape placed upon tabs 41 through 44 in the manner shown in FIG. 4 as tape strip 48 providing security for tab 41. Thus, for maximum security of package 10, a plurality of tape strips similar to tape strip 48 is placed upon base 12 overlapping tabs 42, 43 and 44 in the identical manner shown for tape strips 48 upon tab 41. As mentioned above, in the preferred fabrication of the present invention, tabs 41 through 44 are fabricated to readily break away after several cycles of bending in the manner set forth below in FIGS. 5, 7, 8 and 9. Suffice it to note here that the insertion and bending over of tabs 41 through 44 captivates and maintains the closure of base 12 upon the undersurface of body 11. Conversely, the removal of tabs 41 through 44 freeze the interlocking attachment of base 12 within body 11 allowing base 12 to be removed from body 11 or alternatively rotated with respect to body 11. This operation is described below in greater detail. However, suffice it to note here that rotation of base 12 with respect to body 11 also rotates vehicle platform 46 which in turn supports toy vehicle 60 (seen in FIG. 5). In this manner, the rotational position or display of the toy vehicle may be changed.

[0029] FIG. 5 sets forth a section view of toy vehicle display package 10 taken along section lines 5-5 in FIG. 3. Package 10 includes a generally cylindrical body 11 preferably formed of an opaque material such as cardboard, particleboard of the like. In certain designs however, it is recognized that body 11 may be fabricated of other materials such as plastic or the like and may be translucent or even transparent without departing from the spirit and scope of the present invention.

[0030] Package 10 includes a cap 13 having a simulated wheel 20 defining a rim 22 secured to a simulated rubber tire 17. Simulated tire 17 further defines a simulated tire tread 18. In the preferred fabrication of the present invention, the rubber or plastic material of simulated tire 17 assists in the attachment of cap 13 upon body 11. Preferably a slight friction fit is preferred.

[0031] Package 10 further includes a generally cylindrical inner liner 40 preferably formed of a plastic material or the like which conforms generally to body 11 and which further defines top surface 47 extending across the upper portion of inner liner 40 to provide a closed end thereof. As is better seen in FIG. 7, inner liner 40 further includes a plurality of downwardly extending removable tabs such as tabs 41 and 42 shown in FIG. 5. As mentioned above, tabs 41 through 44, all formed as extensions of inner liner 40, extend downwardly through respective slots formed in base 12. Further, as mentioned above, the inward bending of tabs 41 through 44 provides attachment for base 12 upon the bottom edge of body 11.

[0032] More specifically, base 12 defines a generally cylindrical member having extending lip 45 and a generally

planar vehicle platform 46. As is better seen in FIG. 4, base 12 further defines a plurality of slots 51 through 54 through which respective tabs 41 through 44 extend for attachment of base 12 as described above. By way of illustration, FIG. 5 shows tabs 41 and 42 in the upwardly bent locking position of the tabs. In phantom line depiction, the positions of tabs 41 and 42 are also shown illustrating the downward bending of tabs 41 and 42 in the manner indicated by arrows 61 and 62 respectively.

[0033] Vehicle platform 46 further includes a mirror cover 55 on the upper surface thereof to provide enhanced reflection and enhanced amusement for viewing toy vehicle 60. A pair of attachment posts 70 and 71 extend through and are supported by vehicle platform 46 to engage and secure toy vehicle 60. The attachment of post 70 and 71 to toy vehicle 60 may utilize a variety of attachments as threaded engagement of fasteners or the like. The important aspect with respect to the function of posts 70 and 71 is the secure maintenance of the position of toy vehicle 60 upon vehicle platform 46.

[0034] Package 10 includes a mirror 16 which cover substantially the entire visible rear portion of package 10 surrounding toy vehicle 60. This mirrored surface together with mirror cover 55 provides multiple reflections of vehicle 60 and adds to the interest value of the display vehicle.

[0035] FIG. 6 sets forth a partial sectioned top view of package 10 showing base 12 supported within body 11 such that window aperture 14 and transparent cover 15 in a forward orientation. As described above, the interior rear surface of package 10 is covered by a reflective mirror 16. Toy vehicle 60 is secured to vehicle platform 46 in the manner shown in FIG. 5. A mirror cover 55 substantially covers the visible portion of vehicle platform 46 and extends beneath vehicle 60. The important aspect with respect to the present invention, is the illustration of FIG. 6 the rotational movement of base 12 and vehicle 60 to alternative positions once tabs 41 through 44 (seen in FIG. 4) have been removed from inner liner 40. In this manner the orientation or rotational position of toy vehicle 60 may be selectively altered to provide optimum viewing and display of the toy vehicle.

[0036] FIG. 7 sets forth a partial section view of package 10 taken along 7-7 in FIG. 5. Package 10 includes a base 12 having extending lip 45 and a plurality of slots such as slot 51. Base 12 further defines a generally planar vehicle platform 46 which further supports a mirror cover 55. Body 11 is generally cylindrical in shape and rests upon lip 45. An inner liner 40 generally conforms to the shape of body 11 and includes a plurality of downwardly extending removable tabs such as tab 41. Tab 41 extends through slot 51 of base 12 and provides attachment of base 12 to body 11 when tab 41 is bent upwardly in the phantom line position shown as tab 64 in FIG. 7. A mirror 16 is positioned within body 11 to generally conform to and overlie at least a portion of inner liner 40.

[0037] In the position shown in FIG. 7, tab 41 has been bent downwardly from the phantom line position shown as tab 64 in FIG. 7 to the straight line position shown in solid line representation. Once each of tabs 41 through 45 have been bent downwardly and straightened in the manner illustrated in FIG. 7 for tab 41, base 12 supporting toy vehicle 60 (seen in FIG. 6) may be withdrawn from the

remainder of package 10. Thereafter, repeated bends of tabs 41 through 44 (seen in FIG. 4) causes tabs 41 through 44 to break loose from inner liner 40 and separate in the manner shown in FIG. 8.

[0038] Thus, FIG. 8 illustrates the separation of tab 41 from inner liner 40 and correspondingly illustrates the removal of tab 41. It will be understood that a similar bending and removal of tabs 42 through 44 (seen in FIG. 4) produces a similar break and allows a similar removal of tabs 42 through 44.

[0039] Once the locking tabs of package 10 have been removed, the attachment of base 12 within body 11 assumes the configuration shown in FIG. 9.

[0040] FIG. 9 sets forth a partial section view of the relationship between base 12 and body 11 once the locking tabs have been removed from inner layer 40. As described above, body 11 encloses inner layer 40 and mirror 16 and receives base 12 at the bottom end thereof. Base 12 defines a generally planar vehicle platform 46 having a mirror cover 55. Base 12 further defines a lip 45 and a slot 51. In the configuration shown in FIG. 9, the removal of locking tabs from inner liner 40 allows base 12 to be fitted within the lower end of body 11 to display toy vehicle 60 in the manner shown in FIG. 5 while simultaneously simulating rotation of base 12 and thereby vehicle 60 with respect to body 11 in the manner shown in FIG. 6.

[0041] Thus, once each of the locking tabs have been removed, the display case feature of the present invention package is made available. Closure of base 12 within the lower end of body 11 is readily achieved with the added advantage of rotational position of base 12 to selectively display the rotational position of toy vehicle 60.

[0042] FIG. 10 through 13 set forth an alternate embodiment of the present invention toy vehicle display package generally referenced by numeral 100. By way of overview, package 100 differs from package 10 solely in the fabrication of its cap 104. Unlike cap 13 shown in package 10, cap 104 is a simplified and aesthetically less elaborate cap which is received upon the remainder of package 100 to provide closure. While cap 104 maintains a semblance of the aesthetic simulated wheel tire of cap 13 in package 10, it is achieved in a more limited and less elaborate printed version.

[0043] Continuing by way of overview, package 100 differs from package 10 solely in the user of a more limited cap 104 in place of cap 13 in package 10. All other fabrication of package 100 remains substantially identical to package 10 and thus the descriptions set forth above will be understood to apply equally well to body 101 and associated packaging elements of package 100.

[0044] More specifically, FIG. 10 sets forth a front view of package 100 showing a generally cylindrical body 101 defining a window aperture 102. A window cover 103 preferably formed of a transparent plastic material covers window aperture 102. A base 110 substantially identical to base 12 of package 10 is received upon the lower end of body 101. A toy vehicle 60 is supported within package 100 for display. A cap 104 includes a printed tread 105 on the outer edge thereof. Cap 104 is fitted upon the upper portion of body 101.

[0045] FIG. 11 sets forth a rear view of package 100 showing body 101 supporting base 110 and cap 104. Also shown in FIG. 11 is printed tread image 105 formed upon the outer edge of cap 104.

[0046] FIG. 12 sets forth a top view of package 100. Package 100 includes a printed image cap 104 having a printed wheel image 111 formed thereon. Printed image 111 defines a plurality of apertures 112 through 116 and depicts a plurality of radially extending spokes to simulate the appearance of a vehicle wheel. A top surface 120 substantially identical to top surface 47 of package 10 (seen in FIG. 5) extends across the underside of printed wheel image 111 to provide closure of package 100.

[0047] FIG. 13 sets forth a bottom view of package 100. As mentioned above, the operative closure of package 100 is substantially identical to the above-described closure of package 10. Accordingly, package 100 includes a base 110 received upon body 101 in the manner set forth above in FIG. 10. Base 110 includes a generally planar vehicle platform 121 for supporting a toy vehicle such as toy vehicle 60 shown in FIG. 10. Base 110 further defines a plurality of slots 132, 133, 134 and 135 substantially equally spaced about base 110. Correspondingly, a plurality of tabs 122 through 125 extend through respective slots 132 through 135 and are bent inwardly to the configuration shown for tabs 41 and 42 of package 10 as shown in FIG. 5.

[0048] As mentioned above, base 10 and the remainder of package 100 with the exception of cap 104 (seen in FIG. 12) function in the identical manner to base 12 within body 11 of package 10 described above.

[0049] What has been shown is a toy vehicle display package which provides secure vehicle packaging together with an attractive and amusing vehicle display case structure. The toy vehicle display package described herein provides the novel feature of rotationally positioning the base and platform supporting the toy vehicle in front of a mirrored surface which provides substantial amusement and entertainment for the user.

[0050] While particular embodiments of the invention have been shown and described, it will be obvious to those skilled in the art that changes and modifications may be made without departing from the invention in its broader aspects. Therefore, the aim in the appended claims is to cover all such changes and modifications as fall within the true spirit and scope of the invention.

That which is claimed:

- 1. A toy vehicle display package comprising:
  - a generally cylindrical body defining a window aperture, a top and a bottom;
  - a base receivable within said bottom of said body and defining a plurality of slots and a vehicle support platform;
  - a cap received upon said top of said body; and
  - a plurality of tabs supported by said body and extending through said slots said tabs bending to secure said base to said body, said tabs also being removable.
- 2. The toy vehicle display package set forth in claim 1 further including a mirror supported within said body.
- 3. The toy vehicle display package set forth in claim 2 further including a mirror cover supported upon said vehicle support platform.
- 4. The toy vehicle display package set forth in claim 3 wherein said cap is shaped to resemble a tire and wheel.
- 5. The toy vehicle display package set forth in claim 4 wherein said vehicle support platform includes a pair of toy vehicle support posts.
- 6. The toy vehicle display package set forth in claim 1 wherein said cap is shaped to resemble a tire and wheel.
- 7. The toy vehicle display package set forth in claim 6 further including a mirror cover supported upon said vehicle support platform.
- 8. The toy vehicle display package set forth in claim 7 further including a mirror supported within said body.

\* \* \* \* \*