

(19) **DANMARK**

(10) **DK/EP 3235491 T3**



(12) **Oversættelse af  
europæisk patentskrift**

Patent- og  
Varemærkestyrelsen

- 
- (51) Int.Cl.: **A 61 K 9/00 (2006.01)**                      **A 61 B 5/00 (2006.01)**                      **A 61 B 5/07 (2006.01)**  
**A 61 M 31/00 (2006.01)**                      **G 06 K 5/00 (2006.01)**                      **G 08 B 1/08 (2006.01)**  
**G 08 B 13/14 (2006.01)**
- (45) Oversættelsen bekendtgjort den: **2021-02-08**
- (80) Dato for Den Europæiske Patentmyndigheds bekendtgørelse om meddelelse af patentet: **2020-11-04**
- (86) Europæisk ansøgning nr.: **17170017.2**
- (86) Europæisk indleveringsdag: **2009-03-05**
- (87) Den europæiske ansøgnings publiceringsdag: **2017-10-25**
- (30) Prioritet: **2008-03-05 US 34085 P**
- (62) Stamansøgningsnr: **09717404.9**
- (84) Designerede stater: **AT BE BG CH CY CZ DE DK EE ES FI FR GB GR HR HU IE IS IT LI LT LU LV MC MK MT NL NO PL PT RO SE SI SK TR**
- (73) Patenthaver: **OTSUKA PHARMACEUTICAL CO., LTD., 2-9, Kanda-Tsukasacho, Chiyoda-ku, Tokyo 101-8535, Japan**
- (72) Opfinder: **ROBERTSON, Timothy, 2719 Sequoia Way, Belmont, California 94002, USA**  
**ZDEBLICK, Mark J., 300 La Mesa Drive, Portola Valley, California 94028, USA**
- (74) Fuldmægtig i Danmark: **Murgitroyd & Company, Mannerheimvägen 12 B 5th floor, FI-00100 Helsinki, Finland**
- (54) Benævnelse: **Spiselige hændelsesmarkeringsenheder og systemer med multimodus-kommunikation**
- (56) Fremdragne publikationer:  
**WO-A2-2007/028035**  
**US-A- 3 345 989**



# DESCRIPTION

## INTRODUCTION

**[0001]** Healthcare concerns related to pharmaceutical products include supply chain issues, pharmacy errors and inefficiencies, unintentional disclosures of information related to patients and/or medications, and patient error and misuse of medication. There remains a long-standing need for a safe, cost-effective, comprehensive solution to safeguard medication and protect patients from the consequences of these issues surrounding medications. WO 2007/028035 A2 provides implantable systems that communicate wirelessly with each other. Embodiments provide communication apparatuses and methods for exchanging information with implantable medical devices. In some embodiments, two implantable devices communicate with each other using quasi-electrostatic signal transmission in a long wavelength/low frequency electromagnetic band, with the patient's body acting as a conductive medium. US 3,345,989 relates to an implantable power source employing a body fluid as an electrolyte. A metal electrode is surgically implanted in body tissue. A second electrode, preferably made of platinum black sandwiched between platinum screens, is implanted in another site such as the abdomen. The body fluids serve as an electrolyte for establishing a conductive path for electrons emitted by the first electrode, thus creating a primary electric power source. An implanted electronic device may close the circuit and be supplied by way of insulated leads running from each electrode to the device.

## **SUMMARY**

**[0002]** Aspects of the invention include multi-mode communication ingestible event marker devices. In a first aspect of the invention there is provided an ingestible device comprising: an integrated circuit component comprising a modulator; and a first power source including: a first material associated with the integrated circuit component; and a second material different from the first material; wherein: the second material is associated with the integrated circuit component; the first material and the second material are collectively configured to provide a voltage potential difference when in contact with a conductive fluid of a user ingesting the ingestible device and, upon contact with the conductive fluid, provide power to the integrated circuit component; the integrated circuit component is electrically connected to the first material and the second material; the modulator is configured to modulate a signal associated with at least one of data or the conductive antenna to generate a detectable signal at least partially defined by current flow that extends through the conductive fluid; and the modulator is configured to be powered by a second power source not physically coupled to the modulator in addition to the first power. The communications modules include antennas, integrated circuitry, and/or related components, in various combinations and configurations. Various configurations of the communications unit combine or separate components making up the communications modules, such as antennas, power sources, or integrated circuitry, to achieve a range of

design objectives. Further, the devices can communicate with various other devices, including transmitters/receivers associated with inventory control, pharmacy control, and inter- and intra-body devices.

**[0003]** Additional examples include systems that can be used across multiple and varied applications to provide various benefits across the duration of an ingestible event marker's existence. For example, systems may provide inventory control information related to medication manufacturing and packaging management operations as well as supply chain control. Systems may also provide pharmacy-related quality control measures and personalization applications related to medication, medications packaging, and patient history. Systems may also provide patient safety information as well as safety control measures. Some systems may provide and/or suppress data associated with the system in accordance with preset or dynamically updatable control functions.

**[0004]** Accordingly, examples include devices comprising an ingestible component comprising an integrated circuit comprising a conductive communication module; and a second non-conductive communication module. The second non-conductive communication module comprises, in some instances, at least one module selected from the group consisting of a wireless radio-frequency module, a magnetic induction module, an optical module, an acoustic module, and a wired module. In some instances, the non-conductive communication module is a wireless radio-frequency module that comprises a radio-frequency identification module. In other instances, the non-conductive communication module may be an infrared frequency module. The ingestible component may include a power source, such as a power source made up of a pair of electrodes fabricated from dissimilar materials. Ingestible event marker devices may also include a second power source electrically coupled to the non-conductive communication module, such as a coil, e.g., an RFID coil. In some instances, the ingestible component comprises the non-conductive communication module. In such instances, the non-conductive communication module may be electrically coupled to the integrated circuit of the ingestible component, i.e., the ingestible component integrated circuit. In such instances, the ingestible component integrated circuit, conductive communication module and at least a portion of the non-conductive communication module may be integrated into an ingestible event marker identifier component. In some instances, the non-conductive communication module comprises a non-conductive transmitter, such as an RF antenna, e.g., an RF antenna coil, which may be associated with the ingestible component, such as with a skirt component, or may be associated with a packaging component of the device. In some instances, the non-conductive communication module is electrically coupled to a second integrated circuit that is distinct from the ingestible component integrated circuit. When present, this second integrated circuit and ingestible component integrated circuit may be configured to communicate with each other. In some instances, at least a portion of the non-conductive communication module is configured to be separable from the ingestible component in a manner that does not compromise the function of the conductive communication module. The ingestible component may include an active pharmaceutical agent, which agent may be present in a physiologically acceptable vehicle and/or a skirt component of an ingestible event marker. The physiologically acceptable vehicle may be configured as a tablet or capsule in some instances.

**[0005]** In a second aspect of the invention there is provided a system comprising: a receiver and an ingestible device as described, wherein the device is configured to transmit information via the modulator to the receiver. In some instances, the receiver is configured to receive at least one of the first signal and the second signal. Any of the first and second signals may be encrypted as desired, for example by using any convenient cryptographic protocol. Where the receiver is configured to receive the second signal, in some instances the receiver comprises a radio-frequency reader. As desired, the receiver may be configured transmit information to the non-conductive communication module. In some instances of the system, the receiver is a component chosen from a system selected from the group consisting of manufacturing systems, supply chain management systems and health care management (such as pharmacy) systems. Manufacturing system components which may include a receiver as described herein include sorters, programmers, encoders, etc. Supply chain management system components which may include a receiver as described herein include trackers and programmers. Health care management system components which may include a receiver as described herein include scanners, encoders, and the like. In some instances, the receiver of the system is configured to the first signal, which first signal may comprise non-physiologic data. The receiver may be configured to removably attached to a living being, e.g., via an adhesive component. Alternatively, the receiver may be an implantable receiver. Where desired, the implantable receiver may include additional functionality, such as electrical stimulation functionality, physiological data measurement functionality, etc.

**[0006]** In some instances, the term "Lifecycle" is employed to refer to devices and systems of the invention. "Lifecycle" encompasses the time during which a pharmaceutical product exists, extending from manufacture through destruction. This period includes, for example, medication manufacture, supply chain management, pharmacy management, and patient possession. Lifecycle can also refer to a single phase of the pharmaceutical product existence, or select multiple phases of its existence.

**[0007]** "Pharma Informatics" and "medication data" refer to information regarding medication and its use, including information relating to manufacture, supply chain, pharmacy inventory and distribution, patient identifying data, dosage directions, and consumption data. For example, information used by the system can include the date, time, and location of manufacture, batch number, lot number, medication name, medication type, manufacturer name, pharmacy name, date and time of transfer from pharmacy to patient, time of ingestion, and time of expulsion.

**[0008]** Aspects of RFID systems used for pharmaceutical tracking as discussed in published United States Patent Application Nos. 2007/0008112, 2006/0061472 and 2005/0285732 can also be used in the systems.

#### **BRIEF DESCRIPTION OF THE FIGURES**

**[0009]**

Figures 1A to 1B shows an ingestible event marker identifier according to one embodiment.

Figure 2 shows a communications environment according to one embodiment.

Figure 3 shows the system of Figure 2, according to one embodiment.

Figure 4 shows a cross-sectional view of a system according to another embodiment.

Figure 5 shows a schematic of a first pill communication system, according to one embodiment.

Figure 6 shows a schematic of a second pill communication system, according to one embodiment.

Figure 7 shows a schematic of a third pill communication system, according to one embodiment.

**Figures 8A to 8B** show a first RFID module and a second RFID module, according to one embodiment.

**Figure 9** shows an ingestible event marker identifier that includes a conductive communication module and an RFID communication module, according to one embodiment.

**Figures 10** provides a flow diagram of an IEM product lifetime, according to one embodiment.

**Figure 11** shows a dispenser that may be used in a manufacturing system, according to one embodiment.

**Figure 12** shows a container that may be produced using the manufacturing system of Figure 11, according to one embodiment.

**Figures 13** provides a flow diagram of an IEM product lifetime an illustrates the types of information that may be obtained, according to one embodiment.

**DETAILED DESCRIPTION**

**[0010]** As summarized above, aspects of the invention include multi-mode communication ingestible event marker devices. Ingestible event marker devices of the invention include an ingestible component comprising a conductive communication module and at least one additional non-conductive communication module. The non-conductive communication module may be integrated with the ingestible component or at least a portion or all of the non-conductive communication module may be associated with a packaging component of the ingestible event marker device. Systems of the invention that include the ingestible event

marker devices and a receiver may be configured to provide medication information and control measures across the entire life cycle of the ingestible event marker. The life cycle includes, for example, medication manufacture, supply chain management, pharmacy management, and patient use management.

**[0011]** Ingestible event marker devices of some embodiments may include an ingestible component that includes an integrated circuit component comprising a conductive communication module (for example present as an integrated identifier) and at least a second non-conductive communication module, where the number of additional non-conductive communication modules may vary, for example one or more, two or more, three or more, etc.

**[0012]** Accordingly, the ingestible event marker devices of the invention may be viewed as multi-mode communication ingestible event marker devices, since they include at least two distinct communication modules, one of which is a conductive communication module. As indicated above, the at least second non-conductive communication module may be associated with the ingestible component or partially or wholly associated with a packaging component of the device, if present. As such, ingestible event marker devices of the invention may or may not include packaging associated with the ingestible component, where packaging may be configured in a variety of different formats, such as blister packs, multi-dose containers, and the like. In some instances, the communications modules are dynamically combined with medication components (when present) to achieve highly effective and accurate information and control solutions in a viable, cost-effective manner. For example, in one embodiment, the communications modules are implemented as an integral part of a pill and/or medication packaging. Further, the systems can communicate with various other devices, including transmitters/receivers associated with inventory control, pharmacy control, and inter- and intra- body devices.

**[0013]** As summarized above, the devices and systems of the invention include at least one non-conductive communication module. By non-conductive communication module is meant a communication module that communicates using a communications protocol other than a conductive communication protocol which uses body fluid as a conduction medium (for example, as further described in PCT Published Application Publication Nos. WO 2006/116718; WO 2008/008281 ; WO 2008/095183 and WO 2008/063626). Non-conductive communication protocols, i.e., modes, of interest include, but are not limited to: wireless radio-frequency modes; magnetic induction modes; optical modes, such as infra-red frequency optical modes; acoustic modes; as well as wired modes, i.e., direct modes. Accordingly, in some instances the non-conductive communication module may be at least one module selected from the group consisting of a wireless radio-frequency module, a magnetic induction module, an optical module, an acoustic module, and a wired module.

**[0014]** In some embodiments of interest, the non-conductive communication module is a wireless radio-frequency module. While the wireless radio-frequency communication module may vary, in some instances this module is a radio-frequency identification (RFID) module. For ease of description purposes only, embodiments of the invention will now be further described

in terms of embodiments where the non-conductive communication module is an RFID communication module. However, as noted above the non-conductive communication module may vary widely.

**[0015]** In some instances, the RFID module incorporates, for example, an integrated circuit and an RF antenna. The RFID module may be communicatively associated with a conductive module incorporating, for example, an integrated circuit and a conductive antenna. Either of the RFID module or the conductive module, or both, may function in conjunction with medication and/or medication packaging to receive, process, store, and/or transmit information related to or associated with the medication. As indicated above, the devices and systems can be used across multiple and varied applications to provide secure, controlled, and accurate communications in viable, cost-effective implementations.

**[0016]** Broadly, the devices and systems facilitate information communication and control measures up to the entire life cycle of an ingestible event marker. The systems are capable of application in a variety of communications environments, particularly in environments where wireless communications are preferred. For example, the communications environments include inventory control environments as well as inter-body and intra-body communications.

**[0017]** Inter-body and intra-body communications include, for example, active, passive, and semi-passive systems associated with data transmission and reception from implantable, ingestible, insertable, and attachable medical devices and medications associated with the human body or other living organisms. The medical devices are capable of communication and/or integration with systems of the invention.

**[0018]** As reviewed above, the ingestible event marker devices of the invention include an ingestible component that comprises at least an integrated circuit and a conductive communications module. This structure is collectively referred to herein as an ingestible event marker, and ingestible event markers may or may not include additional components, such as a physiologically acceptable vehicle and/or an pharmaceutically active agent. Accordingly, the ingestible event markers described herein, sometimes referred to herein as "IEMs", at least include an ingestible component that includes an integrated circuit that comprises a conductive communication module, where the conductive communication module includes a conductive transmitter. The integrated circuit and conductive communication module may be collectively referred to as an identifier. Identifiers of interest are structures that generate (for example emit) a detectable signal upon contact of the ingestible event marker identifier with a target physiological location (or locations). The ingestible event marker identifiers may vary depending on the particular embodiment and intended application of the composition, as long as they are activated (turned on) upon contact with a target physiological location, such as the stomach or small intestine. As such, an ingestible event marker identifier may be a structure that emits a signal when activated at a target site, for example when it contacts a target body site. The ingestible event marker identifier may be any component or device that is capable of providing a detectable signal following activation. Ingestible event marker identifiers according to embodiments of the invention include a signal generation component. The ingestible event

marker identifier may be configured to emit a signal once the composition comes into contact with a physiological target site. Depending on the embodiment, the target physiological site or location may vary, where representative target physiological sites of interest include, but are not limited to: a location in the gastrointestinal tract, such as the mouth, esophagus, stomach, small intestine, large intestine, etc. Ingestible event marker identifiers may be configured to be activated upon contact with fluid at the target site, e.g., stomach fluid, regardless of the particular composition of the target site. Where desired, the ingestible event marker identifier may be configured to be activated by interrogation, following contact of the composition with a target physiological site. The ingestible event marker identifier may be configured to be activated at a target site, where the target site is reached after a specified period of time.

**[0019]** Depending on the needs of a particular application, the signal obtained from the ingestible event marker identifier may be a generic signal, such that the signal is a signal that merely identifies that the composition has contacted the target site. Alternatively, the signal may be a unique signal, such as a signal which in some way uniquely identifies that a particular ingestible event marker from a group or plurality of different ingestible event markers, for example a batch of ingestible event markers, has contacted a target physiological site. As such, the ingestible event marker identifier may be one that emits a signal that cannot be distinguished from the signal emitted by the ingestible event marker identifier of any other ingestible event marker member of a batch from which the ingestible event markers are obtained. Alternatively, each ingestible event marker member of a batch of ingestible event markers may have an ingestible event marker identifier that emits a unique signal, at least with respect to all of the other ingestible event marker identifiers of the ingestible event marker members of the batch. The ingestible event marker identifier may emit a unique signal that is a universally unique signal (where such a signal may be analogous to a human fingerprint which is distinct from any other fingerprint of any other individual and therefore uniquely identifies an individual on a universal level). The signal may either directly convey information about a given event, or provide an identifying code, which may be used to retrieve information about the event from a database, such as a database linking identifying codes with compositions. Where desired, the signal may be encrypted in a manner that provides control over access to the signal and informational content thereof.

**[0020]** The ingestible event marker identifier at least generates a conductive (near field) signals, which signal is one that is communicated via a conductive communication protocol that uses body fluid as a conduction medium (for example, as further described in PCT Published Application Publication Nos. WO 2006/116718; WO 2008/008281; WO 2008/095183 and WO 2008/063626). Depending on the given embodiment, the ingestible event marker identifier may transmit a given signal once. Alternatively, the ingestible event marker identifier may be configured transmit a signal with the same information (identical signals), two or more times, where the collection of discrete identical signals may be collectively referred to as a redundant signal.

**[0021]** The ingestible event marker identifiers may vary depending on the particular embodiment and intended application of the composition so long as they are activated upon

contact with a target physiological location, such as the stomach. Ingestible event marker identifiers may include an activation component, such as a battery that is completed by stomach acid, and a transmission element. In these embodiments, the identifier may be viewed as including a "wet battery" power source, which power source at least provides power to the conductive communication module, and may or may not provide power to the non-conductive communication module, as further developed below. Examples of different types of ingestible event marker identifiers of interest include, but are not limited to, those ingestible event marker identifiers described in PCT application serial no. PCT/US2006/016370 published as WO/2006/116718; PCT application serial no. PCT/US2007/082563 published as WO/2008/052136; PCT application serial no. PCT/US2007/024225 published as WO/2008/063626; PCT application serial no. PCT/US2007/022257 published as WO/2008/066617; PCT application serial no. PCT/US2008/052845 published as WO/2008/095183; PCT application serial no. PCT/US2008/053999 published as WO/2008/101107; PCT application serial no. PCT/US2008/056296 published as WO/2008/112577; PCT application serial no. PCT/US2008/056299 published as WO/2008/112578; and PCT application serial no. PCT/US2008/077753.

**[0022]** An example of an ingestible event marker of interest is depicted in Figures 1A and 1B. The ingestible event marker 10 shown in Figures 1A and 1B includes an integrated circuit component 20 (also referred to herein as the identifier) as well as upper and lower electrodes 22 and 24, where the upper and lower electrodes are fabricated from dissimilar materials and are configured such that upon contact with stomach fluid current runs through the integrated circuit to cause one or more functional blocks in the circuit to emit a detectable signal. The marker shown in FIGS. 1 A and 1 B includes a virtual dipole signal amplification element 30 (sometimes referred to herein as a "skirt"), as reviewed in greater detail in PCT application serial no. PCT/US2008/077753.

**[0023]** In one example, the IEM includes a conductive antenna, a conductive modulator, and a wet battery. The digestive system liquids, for example, activate the battery, which acts as a power source for various Ingestible Event Marker components. Detection events occur via liquid contact. Data is transmitted via the conductive antenna to a receiving device.

**[0024]** The ingestible event marker devices may be used in conjunction with receivers configured to receive the conductive signal emitted by the conductive communication module of the ingestible event maker. One example of an attachable medical device is a transmitter/receiver (which may be referred to herein as a Raisin receiver), permanently associated with a body (such as implanted in a body) or removably attachable to an external portion of a body. Receivers of interest include, but are not limited to, those receivers configured to detect a conductively transmitted signal described in PCT Published Application Publication Nos. WO 2006/116718; WO 2008/008281; WO 2008/095183 and WO 2008/063626. As such, the IEM can be communicably associated with a transmitting and/or receiving device such as the Raisin, *supra*. The transmitting/receiving device includes in-body devices, external devices removably or permanently attachable to the body, and remote devices, i.e., devices not physically associated with the body, but capable of communication

with the Ingestible Event Marker.

**[0025]** Various embodiments of the devices and systems, including communication-enabled pills and packaging, enable identification of the IEM and any medication thereof (if present). "Pill" as used below is representative of any communication-enabled medication. IEM packaging includes, for example, a "blister" pack capable of housing an individual IEM (such as a pill or a limited number of pills or capsules). The IEM packaging further includes containers, boxes, wrappings, IV bags, and so forth associated with the medication.

**[0026]** In various embodiments, the communication components can be sovereign to the pill. In other embodiments, the communication components can be distributed, e.g., the RF module or portions thereof are physically associated with the packaging and the conductive communications module is physically associated with the ingestible component, such as a pill or capsule. For example, RFID communications can be terminated when the pill is removed from the packaging due to the physical severance of RFID module components from the remainder of the device. In one embodiment, the RFID antenna is located on the medication packaging and is separated from the remainder of the device via a "snap-off" mechanism, thus preventing RF communications with the ingestible component once it has been removed from its packaging. In another embodiment, the RFID antenna is removed at the time the pharmacy delivers IEM to the patient. In the above examples, other RFID module components, such as a data storage component, can be associated with the RF antenna in such a way that they are separated from the remainder of the system along with the antenna. Alternatively, the RF antenna could remain attached to the pill while another part of the RFID module is separated from the pill. As such, in some instances at least a portion of the non-conductive communication module is configured to be separable from the ingestible component in a manner that does not compromise the function of the conductive communication module. One advantage of separating part or all of the RFID module from the conductive communications module in this manner is the patient privacy protection afforded by termination of RFID communications.

**[0027]** In some embodiments, some or all of the data readable on or written to the RFID system will be removable via severance of the RFID module from the conductive module to protect patient privacy. However, in other embodiments, retention of such data after separation could be desirable for long term tracking and/or identification purposes.

**[0028]** The RFID components can be used to encode the pill or the medication packaging with various data such as medication identification information, dosage information, lot and batch numbers, and expiration dates. These data can be manipulated in any manner to optimize functionality. For example, quality control processes can read each IEM's information and aggregate the information consistent with optimal inventory, shipping tracking, and financial processes. Automated sorters can communicate with each IEM to efficiently process, sort, and package medications.

**[0029]** Similarly, shipping operations can be tracked and controlled to ensure positive

medication identification, medication location, and so forth. In one example, once medication distribution has commenced, the device and system can be used to check for counterfeit medications, such as might be received from international points or from other locations lacking good regulatory practices.

**[0030]** Pharmacy operations can be optimized with use of the devices and systems. For example, upon receipt of medications into the pharmacy, the staff can scan the medication packaging and the medications to ensure receipt of the expected products and authenticity of the medication. Prior to dispensing the medication to a patient, the pharmacy can encode the medication packaging, containers, and individual medications with patient-pertinent information. For example, such information includes patient identification, medication identification and patient-specific dosage and expiration information. Further information includes contraindicated medications, warnings, and so forth. In this manner, the history, traceability, efficacy and safety of the medication are addressed.

**[0031]** In addition, various embodiments of the devices can interoperate with dispensing devices in systems of interest. For example, once medication information is read into the system, the dispensing device aggregates various medications into a container or even a single IEM or formulation for a particular patient.

**[0032]** In various embodiments, the device can be a very small, low range unit. A very strong RF detector, such as an RFID wand or a gate that individual pills pass through, e.g., a funnel as depicted in certain of the figures, can be used to communicate with the device outside the body, for example, within a range of 100  $\mu\text{m}$  to ten meters, such as 3  $\mu\text{m}$  to 3 centimeters, e.g. approximately 1 centimeter. Once ingested, however, the low range of the RFID communication module does not facilitate communication with random devices, i.e., those not intended or authorized to communicate with the IEM. In this manner, privacy concerns regarding unauthorized or unintentional communication of information associated with the IEM are minimized. Higher range RFID devices i.e., functioning with in a range of one meter to 20 meters, such as one meter to three meters, e.g. 2 meters, may be employed for some tracking applications. In this application, privacy protection can be provided by separation of RFID and conductive communications modules as described above. Alternatively, privacy may be provided in this and any particular communication by employing suitable encryption techniques, such that any signal of interest where privacy considerations are of concern is encrypted. Any convenient encryption protocol may be employed.

**[0033]** The frequency range in which the RFID module operates can also be selected to achieve various design goals. Low frequency RF, i.e. radio waves in the Hz/kHz range, for example, between 5 kHz and 500 kHz, such as 125 kHz, may be preferable for communications while the device is in use by the patient. However MHz/GHz range RF, e.g. in the range of 1 MHz to 1 GHz, such as 13.56 MHz, can facilitate tracking of the system prior to patient use. Multiple RFID modules can be combined within one system to facilitate these different needs.

[0034] Once the IEM reaches the patient environment, information associated with the IEM can be used for a variety of purposes. For example, the IEM may interoperate with the IEM container and with a receiver such as the Raisin, *supra*, to ensure that the person attempting to open the IEM container is actually the person for whom it is prescribed. Further communication activities include an information control system, in which medication information associated with the IEM device is compared against patient data received from one or multiple sources to determine, for example, if a medication is contraindicated, subject to appropriate dosage amounts and times, or other events and/or conditions.

[0035] After patient ingestion, information stored by the IEM may be recovered from one or more of the communications modules. For example, communication capabilities can be performed after ingestion via the conductive communication components, for example, using the Ingestible Event Marker and a Raisin receiver. In some embodiments, a device with a limited RF range maintains patient privacy respecting to information stored by the system. Other embodiments of the system provide for separation of RFID module components to prevent RF access to the device.

[0036] Data can be stored in the device and reprogrammed with secure digital signature at each transaction.

[0037] When patient expulsion of a IEM has taken place, various embodiments permit communication with a device such as a sensor to determine, for example, data related to the patient or the medication, or transit time through the body. Alternatively, in various embodiments, the data is erased (or various components/subcomponents associated with the data are destroyed or separated from the system) to protect privacy concerns after expulsion.

[0038] In **Figure 2**, there is shown a communications environment 100 including an ingestible event marker device 102, according to one embodiment, which includes both a conductive communication module and an RFID module. The RFID module of the device 102 interacts via a communication link 104 with a receiver configured to receive a signal from at least one of the conductive communication module or RFID communication module of the device. For example, receiver 106 may be an RFID wand 106. In communication environment 100, the device 102 interacts with, e.g., brings in power from, the RFID wand 106. The RFID wand 106, for example, operates on a radio frequency and transmits data to and/or receives data from the device 102. In this manner, communication can be achieved without reliance on liquid contact to activate a power source. In addition, in certain embodiments, the device 102 is powered by the radio signal of the associated communication device, e.g., RFID wand 106. In this manner, the device 102 provides a relatively small size overall to facilitate ease of ingestion, implantation, maintenance, and traversal activities related to the body.

[0039] More particularly, **Figure 3** shows the ingestible event marker device 102 of Figure 1, according to one embodiment. The device 102 includes a pill 202 and a communications module 204. The communications module includes an integrated circuit ("chip") 206, an RF antenna 208, lead(s) 210, and an antenna skirt 212. The pill 202 may have various

pharmaceutical configurations, such capsules, caplets, gel caps, solid pills, tablets, and other types of pill medications. The pill 202 may include a physiologically acceptable vehicle, and may or may not further include a pharmaceutically active agent. The chip 206 is permanently or removably affixed to, or integrated with, at least a portion of the pill 202. The chip 206 includes various combinations of components/subcomponents (not shown). For example, the chip 206 can include or be otherwise associated with a memory, a processor, a storage unit, a transmitter and/or receiver, or other components associated with data processing, storage, transmission, and receipt.

**[0040]** The RF antenna 208 permanently or removably attaches to, or is otherwise in communication with, the chip 206 via leads 210. In various embodiments, the antenna 210 is integrated, or otherwise associated with, the antenna skirt 212 (also referred to above as a virtual-dipole signal amplifier). In various embodiments, the antenna skirt 212 can be flexible, inflexible, foldable, unfoldable, rollable, unreliable, expandable or otherwise manipulated. In this manner, the folded antenna skirt 212 facilitates ingestion/implantation, yet expands in the body to promote communication transmittal and reception. The antenna skirt can be implemented in various materials or combinations of materials, so long as the functionality described herein is carried out.

**[0041]** **Figure 4** shows a cross-sectional view of an ingestible event marker device 300, according to another embodiment. The ingestible event marker 300 includes packaging 302, such as a "blister" pack. Chip 206 of device 300 includes an RFID communication module electrically coupled to the RF antenna 208 via the leads 210. The RF antenna 208 can be integrated into or formed in any manner associated with the packaging 302. The chip 206 can be located or associated with either the blister pack, e.g., where separate communicably associated chips can be attached to the blister pack and the pill. Alternatively, chip 206 may be part of an ingestible component (not shown) such as a pill, such as where chip 206 further includes a conductive communication module. Communication associated with the blister pack can be achieved without having all of the RFID components onboard an ingestible component, thus providing an alternative to ingestion of the entire RFID communication. Therefore, the RFID off-board components, i.e., components not physically associated with the ingestible component, need not consist of edible materials.

**[0042]** As illustrated below, an RFID communication module 204 may be associated to varying degrees with conductive components of an IEM. For example, **Figure 5** shows a schematic of a first pill communication system 400, sometimes referred to as a "sender", including the RF antenna 208 powered by an induction power source 402. The induction power source 402 includes, for example, the RFID wand 106 (shown in Figure 2). The RF antenna 208 is communicably associated with a first modulator 404, which modulates a signal associated with data 406, which can be stored, for example, in a memory (not shown) or other media.

**[0043]** The pill communication system 400 further includes a conductive antenna 408 powered by a wet battery 410. The wet battery 410 is activated, for example, by digestive liquids. The conductive antenna 408 is communicably associated with a second modulator 412, which

modulates a signal associated with the conductive antenna 408. The second modulator 412 is communicably associated with data 406, which can be associated, for example, in a memory (not shown) or other media. In this manner, common data, e.g. data 406 can be transmitted via two different links, depending on the desired functionality.

**[0044]** For example, data can be modulated and transmitted via the RF antenna 208 during manufacturing, shipping, pharmacy, and home operations. The same (or different) data can be transmitted via the conductive antenna 408 after ingestion of the pill. In various embodiments, after expulsion from the body, a time of expulsion can be determined and used, for example, to calculate a total transmittal time through the body.

**[0045]** In some embodiments, some or all of the data stored on the system can be erased, destroyed, etc. For example, the pill includes fusible links (not shown) and use a portion of the power to completely erase data from memory or physically destroy memory. For example, when the conductive communication module power source, e.g. wet battery, is activated, the power provided triggers data deletion. In this manner, if the pill is recovered there is no data to be retrieved by unauthorized sources and the patient's privacy interests are preserved. Separating the data into separate modules (not shown) further allows a portion of stored data to be deleted, e.g. patient or dosage information, while allowing a portion of the data to remain, e.g. medication identifying information.

**[0046]** A further advantage offered by separation between portions of the RFID communications module and the conductive communications module is a failsafe mechanism for obtaining data stored on the pill. That is, if one communications module fails, the other module remains available to facilitate communications. For example, if one or more components of the conductive communications module cease to function, an RFID wand 106 (shown in Figure 2) could be used to power the pill communication system 400 inductively to obtain information from data 406.

**[0047]** Moreover, separating the conductive communication module from the RFID communication module components facilitates physical disabling of a part of the system via a "snap-off" mechanism as described *supra*.

**[0048]** **Figure 6** shows a schematic of a second pill communication system 500, according to one embodiment. The second pill communication system includes a spiral conductive RF antenna 502, an RF modulator 404, a conductive modulator 412 and data 406. The antenna is communicably associated with an RF modulator 404 powered by an induction power source. The RF modulator 404 modulates a signal associated with the antenna. The RF modulator 404 is communicably associated with data 406, which can be associated, for example, in a memory (not shown) or other media. The antenna 502 is further communicably associated with a conductive modulator 412 powered by, e.g., a wet battery. The conductive modulator modulates a signal associated with the antenna. The conductive modulator is communicably associated with data 406, which can be associated, for example, in a memory (not shown) or other media. In this manner, the second pill communication system accommodates both

conductive and RF modulation of signals associated with a single antenna. An IEM device featuring a single antenna which facilitates both conductive and RF communications would potentially reduce the component, design, and test costs associated with the complete system. Moreover, the modes of failure are reduced as components are removed from the system. The potential for antenna failure is reduced when the system includes one antenna rather than two.

**[0049]** Figure 7 shows a schematic of a third pill communication system 600, according to one embodiment. The third pill communication system 600 includes an antenna 502, a modulator 602, and data 406. The modulator 602 modulates a signal from the antenna 502 and can be powered by one or more sources, e.g., a wet battery and/or an inductive power source. In one embodiment, for example, the modulator 504 is a 125 Kilohertz (KHz) modulator. In other examples, the modulator is a 13 Megahertz (MHz) modulator or other frequency bands. In this manner, the second pill communication system 500 accommodates both inductive and conductive power sources in a single modulator/antenna design, permitting multiple types of communication in multiple communication environments. The advantages of component integration as illustrated in Figure 5, *supra*, are further realized with further reduction of the number of components in the system.

**[0050]** Figures 8A and 8B show a first RFID module 602 and a second RFID module 604, according to one embodiment. The first RFID module 602 is configured in association with a small chip 606 (integrated circuit or flexible electrode). The small chip 606 is, for example, between 10 micrometers and 10 millimeters on a side, such as 100 micrometers to 5 millimeters, e.g. one millimeter on a side, having a cathode on a first side (not shown) and an anode on a second side (not shown). The chip 606 is embedded in a skirt 608 by which conductive transmission is generated by modulating current. An antenna 504 runs along, i.e., is associated with, the perimeter of the chip 606. The antenna 504 includes, for example, a multi-turn/multi-layer antenna that acts as the antenna for an RFID link. In one embodiment, the antenna is relatively small. In various embodiments, an insulating layer (not shown) is introduced over the antenna 504 to extend range. For example, the insulating layer includes several hundred microns of plastic over the antenna 504. In this manner, the pharmaceutical RFID unit 602 is compact, and therefore easily ingestible/implantable while still operable in an acceptable communication range. In various other embodiments, the antenna 504 matches a refractive index of the body. In this manner, the RFID antenna facilitates interbody, intrabody, and extrabody communications.

**[0051]** The second RFID module 604 is configured in association with a small chip 606 having a cathode layer (not shown) on top of the chip 606. The layer of metal is patterned with the antenna 504, e.g., densely patterned with the antenna 504 having a multi-turned, spiral-patterned design. The metal layer has slits cut therein, such as single spiral slit cut. When the cathode material is deposited, the antenna 504 serves as a conductor which provides the substrate for attaching the cathode and also the current collector for extracting electrical energy from it. In this manner, the antenna 504 becomes shorted when wet, thus permitting the RFID module to function in a dry environment (manufacturing, pharmacy, etc.) but not in liquid environment, e.g., inside the body. This promotes privacy by disabling RFID

communications with the lifecycle pharma informatics system while it is in the body.

**[0052]** In various embodiments, the antenna 504 is configured according to any pattern and/or location respective to the lifecycle pharma informatics system. Patterns include, for example, spirals, squiggles, curves, multi-turned, straight, curved, single layer, multi-layer, and other designs and combinations of designs.

**[0053]** Figure 9 shows an ingestible event marker identifier that includes an RFID communication module, according to an embodiment. In Figure 9, IEM identifier 900 includes integrated circuit component 910 and skirt 920. Integrated circuit component 910 includes both a conductive communication module and an RFID communication module. Identifier 910 also includes RFID antenna 930.

**[0054]** IEM identifiers that include both conductive communication modules and non-conductive communication modules, such as RFID communications modules, find use in a variety of different applications which may span the product lifetime of an ingestible event marker. Abilities and functionalities provided by such identifiers include, but are not limited to: reading of IEM identifier information and storing pedigree information at one or more of the IEM manufacturing stage, supply chain stage, pharmacy management stage, and patient use stage. Complete pedigrees for a given IEM, from manufacture to use and/or disposal may readily be obtained. Audit capability may be provided at every point in the supply chain. Automated sorting gates and cryptographic signatures may be employed to verify product authenticity, as desired.

**[0055]** IEM devices including both conductive communication and non-conductive communication modules may be fabricated using any convenient manufacturing protocol. In some instances, the manufacturing protocol that is employed is a high-throughput manufacturing protocol. Such high-throughput manufacturing protocols include, but are not limited to, those described in United States Provisional Application Serial No. 61/142,849. One high-throughput manufacturing protocol in which the IEM includes an identifier having both conductive and RFID communication modules and a tablet physiologically acceptable carrier that includes an active pharmaceutical agent is schematically illustrated in Figure 10. The process 1000 illustrated in Figure 10 begins with an IEM identifier 1010 that includes a conductive and RFID communication module (such as the identifier illustrated in Figure 9) being combined with an active pharmaceutical agent (API) and a physiologically acceptable vehicle 1020 into a tablet IEM at stage 1030. Following tablet compression, the resultant tablet may be coated at stage 1040 and any printing or labeling applied at stage 1050 to produce the final IEM. Next, the IEM is sent to bulk packaging stage 1060, where the resultant bulk package of IEMs is shipped at stage 1070 to pharmacy 1080 for ultimate sale to a customer. Box 1090 illustrates examples of points in the process where the RFID communication module may be employed to transmit information to the IEM and/or receive information from the IEM. For example, programming information may be transmitted to the IEM via the RFID communication module at any of points 1092, 1094, 1096 and 1098. Alternatively and/or in addition to transmitting programming information to the IEM via the RFID communication

module at any of points 1092, 1094, 1096 and 1098, identifying information may be retrieved from the IEM at any of these points, e.g., to facilitate packaging, sorting, handling, etc.

**[0056]** Figure 11 provides a view of a sorter device that includes an RFID receiver/transmitter, where the sorter device may be used in a manufacturing, and supply chain and/or pharmacy system (for example at any of points 1092, 1094, 1096 and 1098. In Figure 11, hopper 1100 includes a larger number of IEMs 1110, where the IEMs include both conductive and RFID communication modules, such as the IEM shown in Figure 9. Funnel 1120 dispenses IEMs into dispenser counter 1130. Dispenser counter 1130 includes 1, 2 or 3 coils 1135 for RFID communication (where three are shown in the figure). Dispenser counter includes tube 1137 which ensures dispensing of a single IEM at a time into container 1140. Container 1140 is filled with identified and sorted IEMs.

**[0057]** An example of an embodiment of container 1140 is shown in Figure 12. Container 1140 of figure 12 includes multiple IEMs 1110 that have been identified by system 1100. Container also includes an RFID tag, 1150 and a bar code 1160. Also shown is cap 1170. The system 1100 and container 1140 may be employed with an informatics system to readily know the exact contents of the container, including the pedigree information for each IEM present in the container.

**[0058]** Figure 13 provides a flow diagram of an IEM product lifetime and provides examples of the types of information that be generated by IEM devices that include both conductive and non-conductive communication modules. In Figure 13, raw materials from raw material suppliers 1300 are sent to manufactures 1310 for manufacture of IEMs. Distributor 1315 and 1320 transfer IEMs from the manufacture to a pharmacy, such as a hospital pharmacy 1330 or retail pharmacy 1335, and ultimately to a patient 1340. Non-conductively communication information may be employed prior to patient ingestion to, among other activities, provide for product authentication the manufacturer 1310 and the first distributor 1315, provide for verified product repackaging between the first distributor 1315 and the second distributor 1320, accurately implement prescription filling at pharmacy 1330 or 1335 with fewer filling errors. Conductively obtained information can be employed to obtain dosing information from the patient 1340 which is employed by health care practitioners 1350 as well as pharmacies (to manage prescriptions) and manufacturers 1310 (for market intelligence, such as sales projections, etc.). Uses of conductively obtained IEM information are further described in PCT Published Application Publication Nos. WO 2006/116718; WO 2008/008281; WO 2008/095183 and WO 2008/063626.

**[0059]** It is to be understood that this invention is not limited to particular embodiments described, as such may vary. It is also to be understood that the terminology used herein is for the purpose of describing particular embodiments only, and is not intended to be limiting, since the scope of the present invention will be limited only by the appended claims.

**[0060]** Where a range of values is provided, it is understood that each intervening value, to the tenth of the unit of the lower limit unless the context clearly dictates otherwise, between the

upper and lower limit of that range and any other stated or intervening value in that stated range, is encompassed within the invention. The upper and lower limits of these smaller ranges may independently be included in the smaller ranges and are also encompassed within the invention, subject to any specifically excluded limit in the stated range. Where the stated range includes one or both of the limits, ranges excluding either or both of those included limits are also included in the invention.

**[0061]** Unless defined otherwise, all technical and scientific terms used herein have the same meaning as commonly understood by one of ordinary skill in the art to which this invention belongs. Although any methods and materials similar or equivalent to those described herein can also be used in the practice or testing of the present invention, representative illustrative methods and materials are now described.

**[0062]** The citation of any publication is for its disclosure prior to the filing date and should not be construed as an admission that the present invention is not entitled to antedate such publication by virtue of prior invention. Further, the dates of publication provided may be different from the actual publication dates which may need to be independently confirmed.

**[0063]** It is noted that, as used herein and in the appended claims, the singular forms "a", "an", and "the" include plural referents unless the context clearly dictates otherwise. It is further noted that the claims may be drafted to exclude any optional element. As such, this statement is intended to serve as antecedent basis for use of such exclusive terminology as "solely," "only" and the like in connection with the recitation of claim elements, or use of a "negative" limitation.

**[0064]** Certain ranges have been presented herein with numerical values being preceded by the term "about." The term "about" is used herein to provide literal support for the exact number that it precedes, as well as a number that is near to or approximately the number that the term precedes. In determining whether a number is near to or approximately a specifically recited number, the near or approximating unrecited number may be a number which, in the context in which it is presented, provides the substantial equivalent of the specifically recited number.

**[0065]** As will be apparent to those of skill in the art upon reading this disclosure, each of the individual embodiments described and illustrated herein has discrete components and features which may be readily separated from or combined with the features of any of the other several embodiments without departing from the scope of the present invention. Any recited method can be carried out in the order of events recited or in any other order which is logically possible.

**[0066]** Although the foregoing invention has been described in some detail by way of illustration and example for purposes of clarity of understanding, it is readily apparent to those of ordinary skill in the art in light of the teachings of this invention that certain changes and modifications may be made thereto without departing from the scope of the appended claims.

[0067] Accordingly, the preceding merely illustrates the principles of the invention. It will be appreciated that those skilled in the art will be able to devise various arrangements which, although not explicitly described or shown herein, embody the principles of the invention and are included within its scope. Furthermore, all examples and conditional language recited herein are principally intended to aid the reader in understanding the principles of the invention and the concepts contributed by the inventors to furthering the art, and are to be construed as being without limitation to such specifically recited examples and conditions.

[0068] Moreover, all statements herein reciting principles, aspects, and embodiments of the invention as well as specific examples thereof, are intended to encompass both structural and functional equivalents thereof. Additionally, it is intended that such equivalents include both currently known equivalents and equivalents developed in the future, i.e., any elements developed that perform the same function, regardless of structure. The scope of the present invention, therefore, is not intended to be limited to the exemplary embodiments shown and described herein. Rather, the scope of the present invention is embodied by the appended claims.

## REFERENCES CITED IN THE DESCRIPTION

This list of references cited by the applicant is for the reader's convenience only. It does not form part of the European patent document. Even though great care has been taken in compiling the references, errors or omissions cannot be excluded and the EPO disclaims all liability in this regard.

### Patent documents cited in the description

- [WO2007028035A2 \[0001\]](#)
- [US3345989A \[0001\]](#)
- [US20070008112A \[0008\]](#)
- [US20060061472A \[0008\]](#)
- [US20050285732A \[0008\]](#)
- [WO2006116718A \[0013\] \[0020\] \[0021\] \[0024\] \[0058\]](#)
- [WO2008008281PCT \[0013\] \[0020\] \[0024\] \[0058\]](#)
- [WO2008095183PCT \[0013\] \[0020\] \[0024\] \[0058\]](#)
- [WO2008063626PCT \[0013\] \[0020\] \[0024\] \[0058\]](#)
- [US2006016370W \[0021\]](#)
- [US2007082563W \[0021\]](#)
- [WO2008052136A \[0021\]](#)
- [US2007024225W \[0021\]](#)
- [WO2008063626A \[0021\]](#)

- US2007022257W [0021]
- WO2008066617A [0021]
- US2008052845W [0021]
- WO2008095183A [0021]
- US2008053999W [0021]
- WO2008101107A [0021]
- US2008056296W [0021]
- WO2008112577A [0021]
- US2008056299W [0021]
- WO2008112578A [0021]
- US2008077753W [0021]
- US2008077753W [0022]
- US61142849B [0055]

PATENTKRAV

1. En spiselig enhed omfattende:  
5 en integreret kredsløbskomponent omfattende en modulator; og en første strømkilde  
inklusive:  
et første materiale associeret med den integrerede kredsløbskomponent; og  
et andet materiale forskelligt fra det første materiale;  
hvor:  
10 det andet materiale er associeret med den integrerede kredsløbskomponent;  
det første materiale og det andet materiale er kollektivt konfigureret for at tilvejebringe  
en spændingspotentialforskel når i kontakt med en ledende væske i en bruger, der  
indtager den spiselige enhed og, ved kontakt med den ledende væske, at tilvejebringe  
effekt til den integrerede kredsløbskomponent;  
15 den integrerede kredsløbskomponent er elektrisk forbundet med det første materiale og  
det andet materiale; enheden omfatter derudover en ledende antenne koblet til  
modulatoren, hvor  
modulatoren er konfigureret for at modulere et signal associeret med mindst en af data  
eller den ledende antenne for at generere et registrerbart signal mindst delvist defineret  
20 af strøm, der udvider sig igennem den ledende væske; og  
modulatoren er konfigureret til at blive drevet af en anden strømkilde, der ikke er fysisk  
koblet til modulatoren foruden den første strømkilde.
2. Enheden ifølge krav 1, hvor antennen er konfigureret til at gøre både det ledende signal  
25 og et kommunikationssignal radiofrekvens, RF, nemmere.
3. Enheden ifølge ethvert af kravene 1-2, hvor den anden strømkilde omfatter en ledende  
strømkilde.
4. Enheden ifølge ethvert af kravene 1-3, derudover omfattende en hukommelse koblet til  
30 modulatoren.
5. Enheden ifølge ethvert af kravene 1-4, hvor enheden er spiselig, og den integrerede  
kredsløbskomponent drives under indtagelse.
- 35 6. Enheden ifølge ethvert af kravene 4-5, hvor data gemt i hukommelsen er konfigureret til  
at blive slettet ved aktivering af det integrerede kredsløb af de første og anden  
materialer i kontakt med den ledende væske.

7. Enheden ifølge ethvert af kravene 1-6, derudover omfattende et aktivt farmaceutisk middel.
8. Enheden ifølge ethvert af kravene 1-7, hvor modulatorens betjening sker ved 125 KHz.
9. Enheden ifølge ethvert af kravene 1-7, hvor modulatorens betjening sker ved 13 MHz.
10. Enheden ifølge ethvert af kravene 1-9, hvor den anden strømkilde er associeret med et sporingsapparat konfigureret til at revidere enheden.
11. Enheden ifølge ethvert af kravene 1-10, hvor enheden er formet i en kapselkonfiguration.
12. Enheden ifølge ethvert af kravene 1-10, hvor enheden er formet i tabletkonfiguration.
13. Et system omfattende en modtager og en enhed ifølge ethvert af kravene 1-12, hvor enheden er konfigureret til at overføre informationer via modulatorens betjening til modtageren.

# DRAWINGS

FIG. 1A

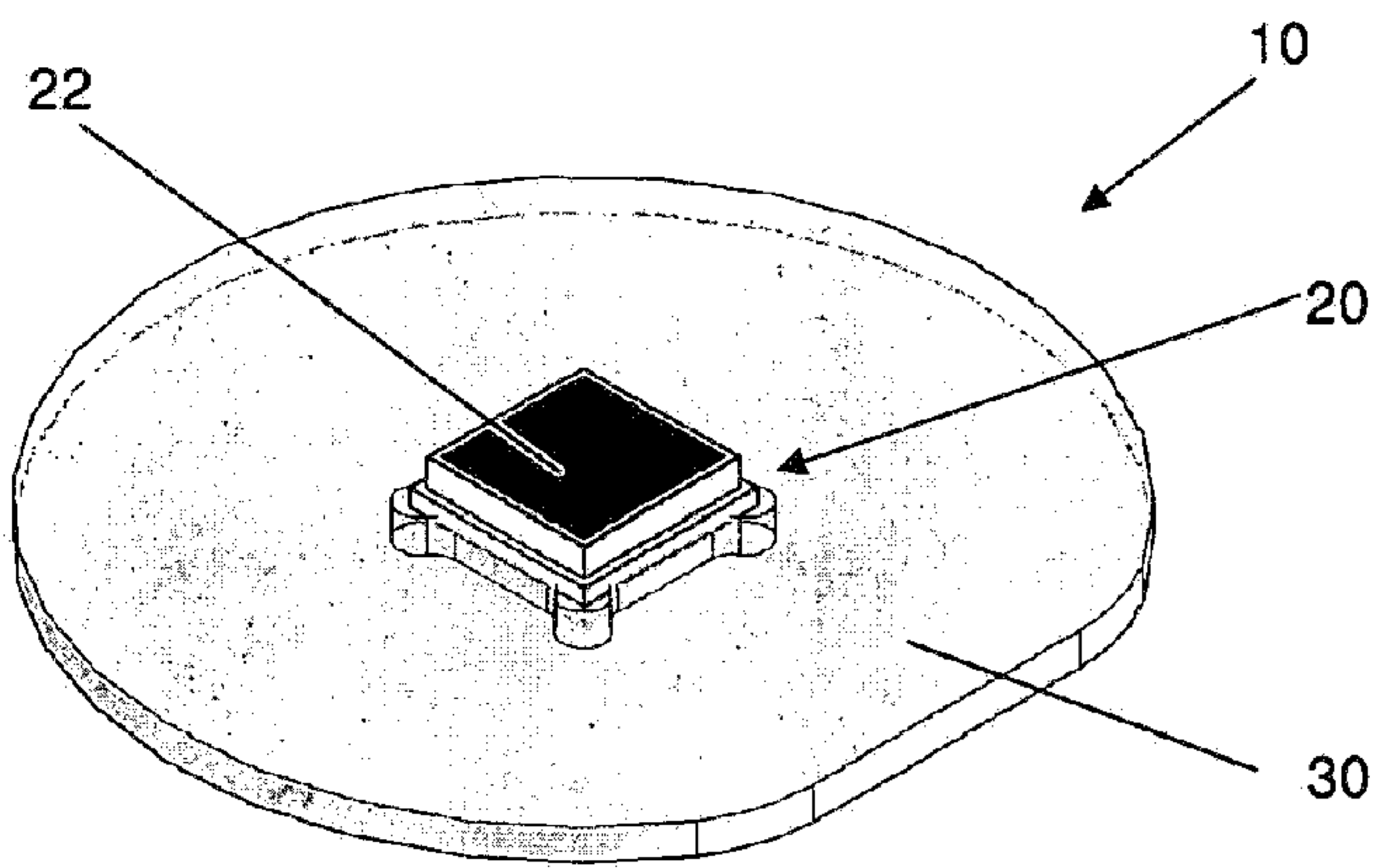

FIG. 1B

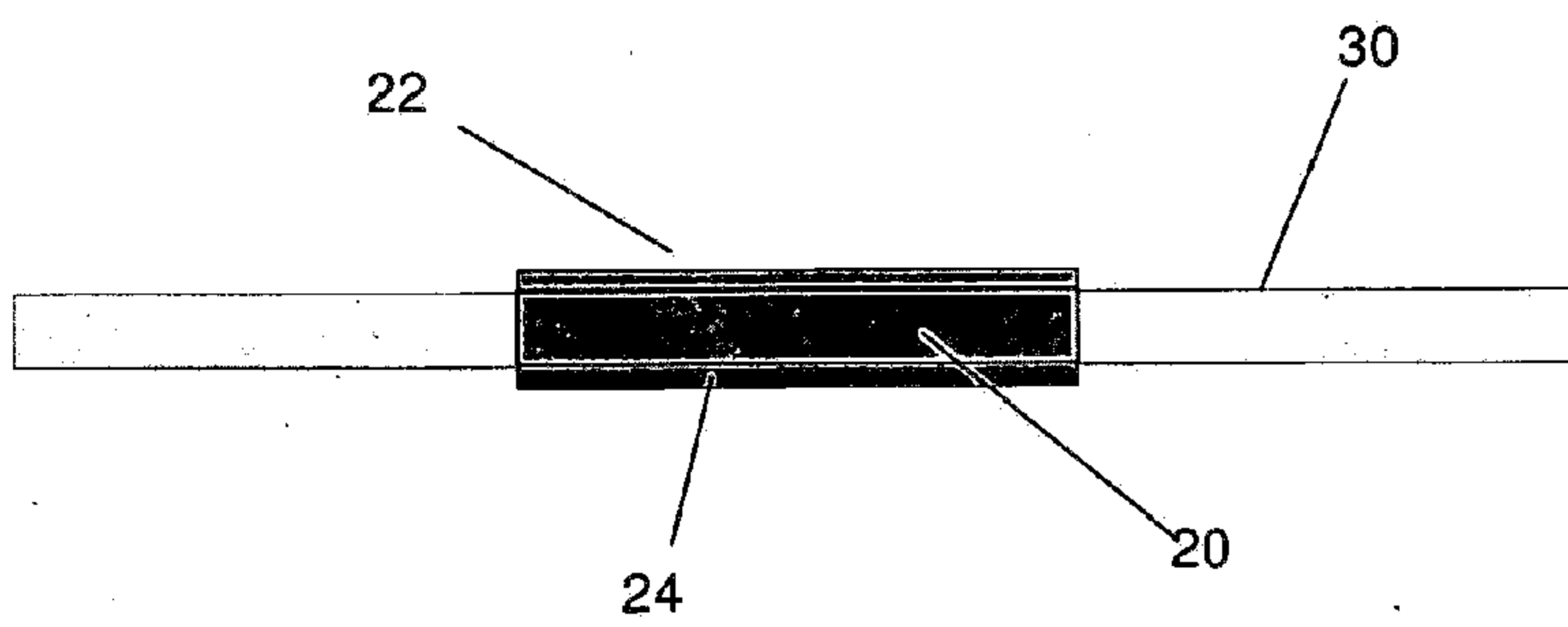

FIG. 2

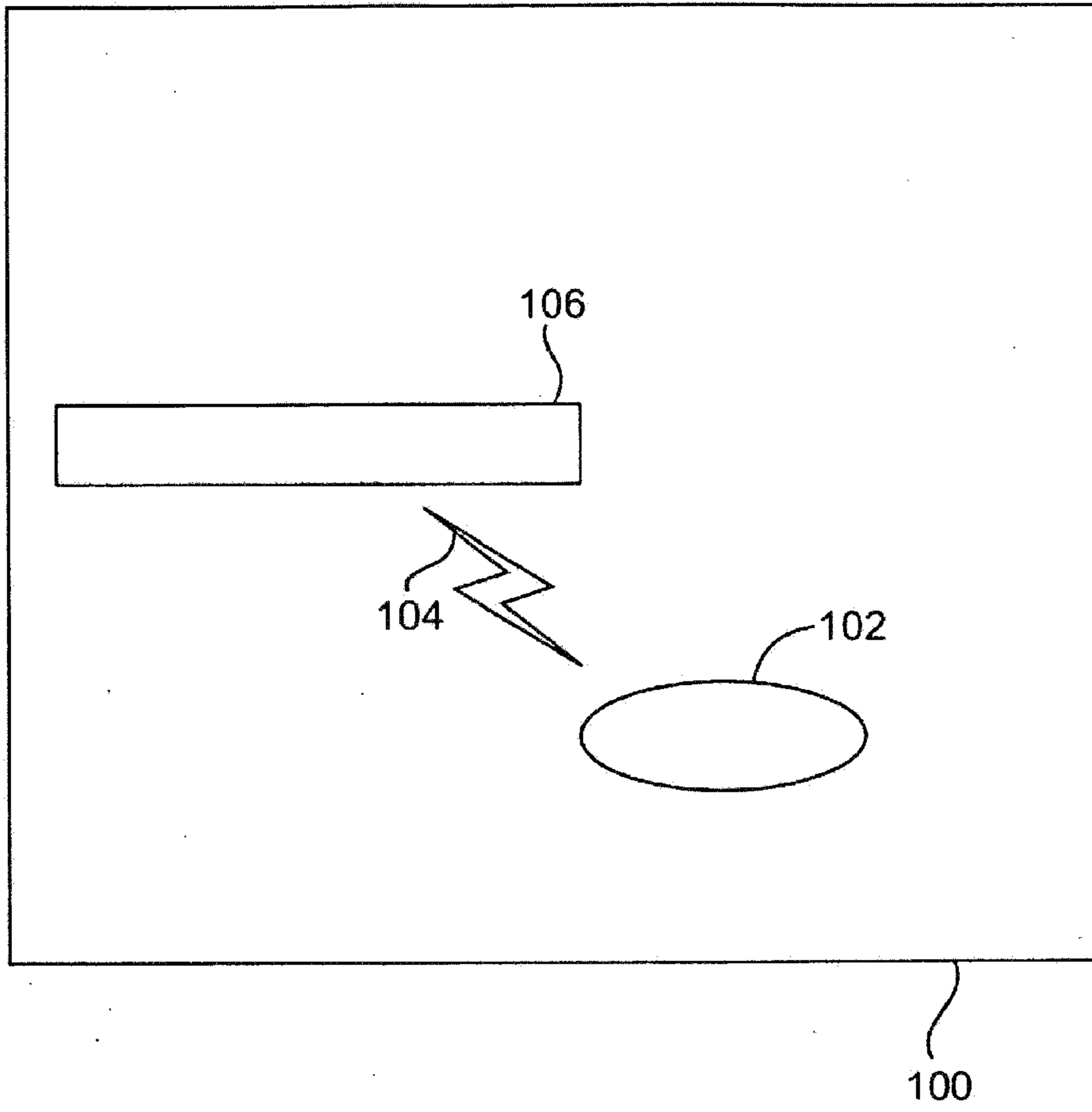

FIG. 3

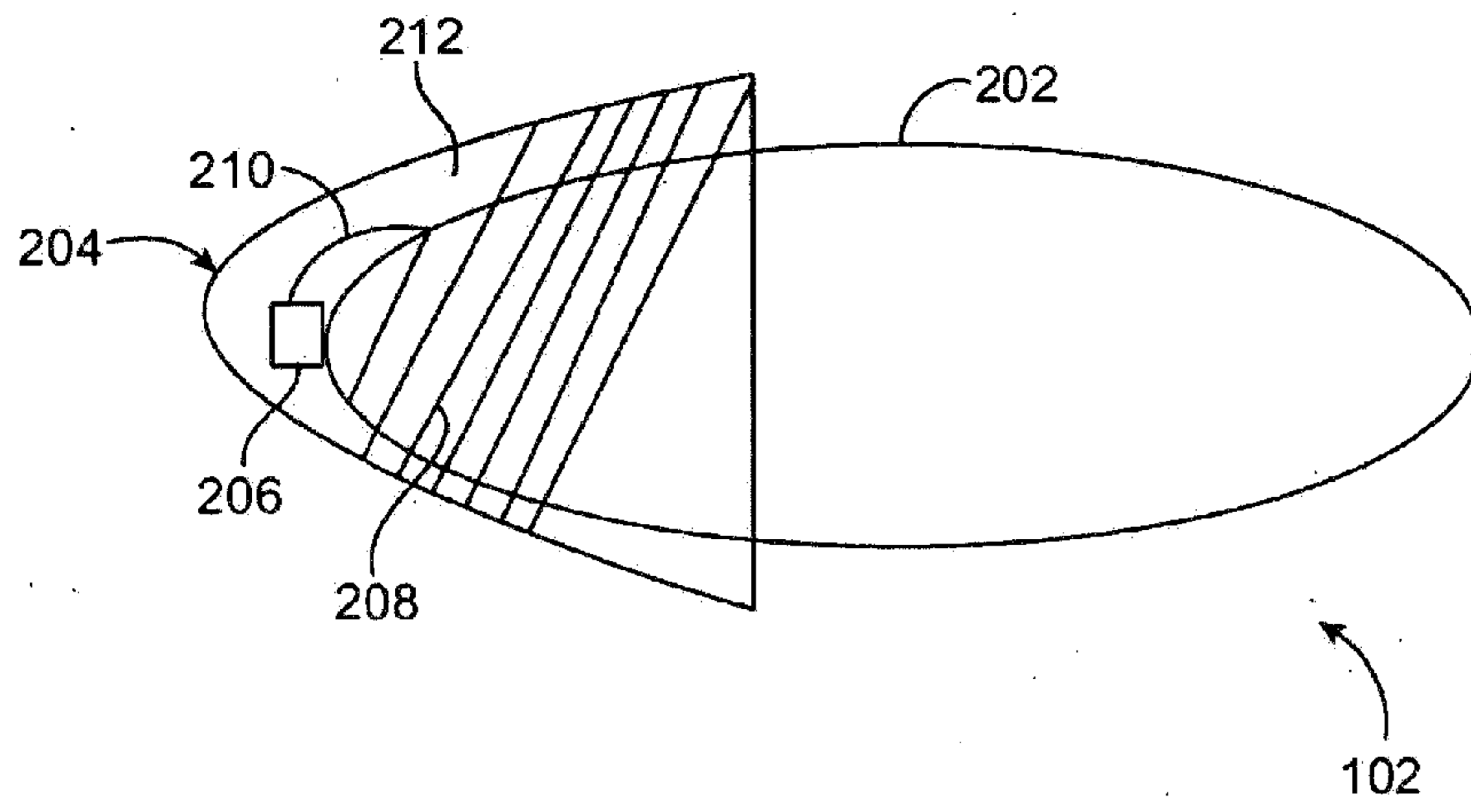

FIG. 4

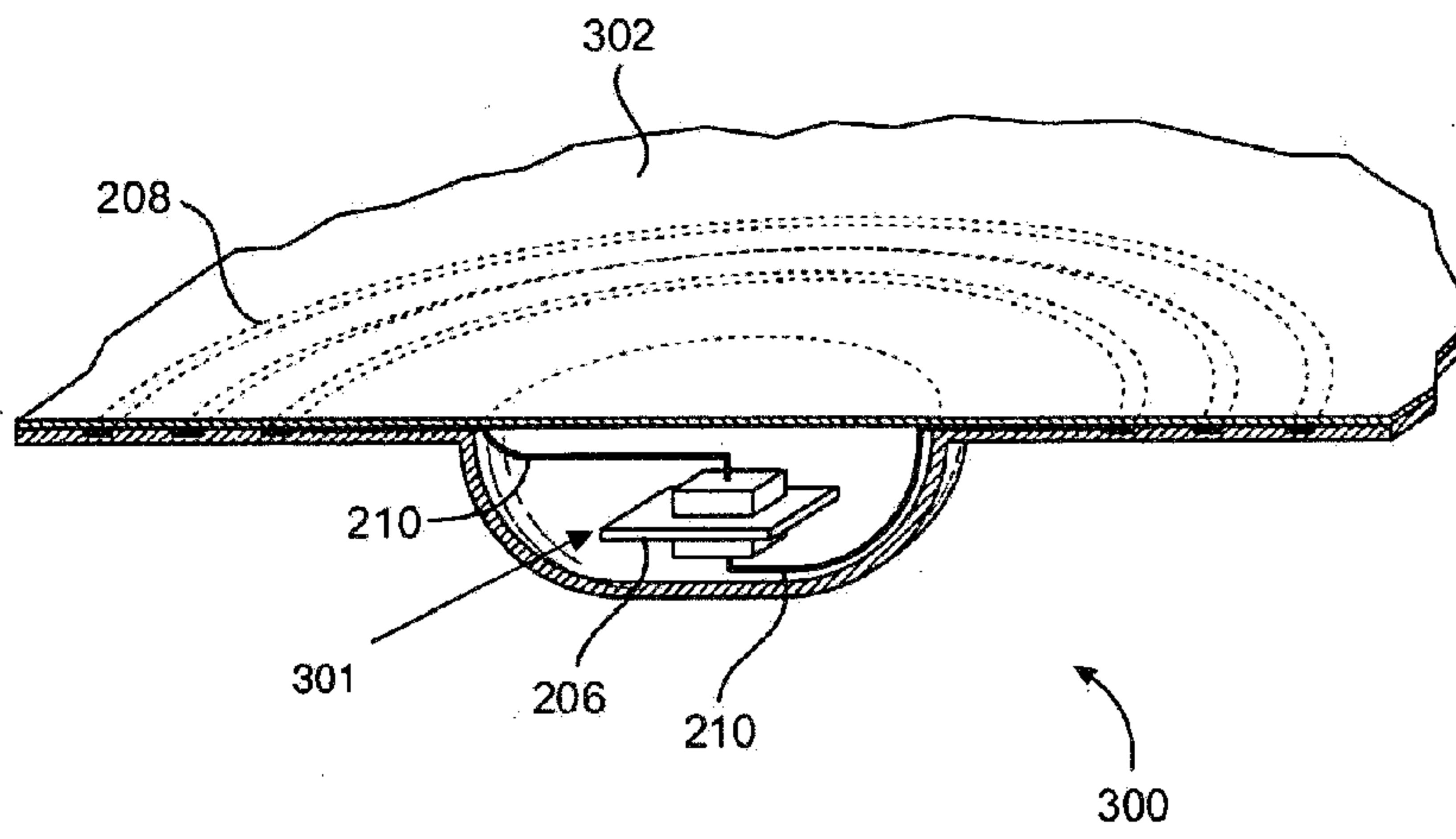
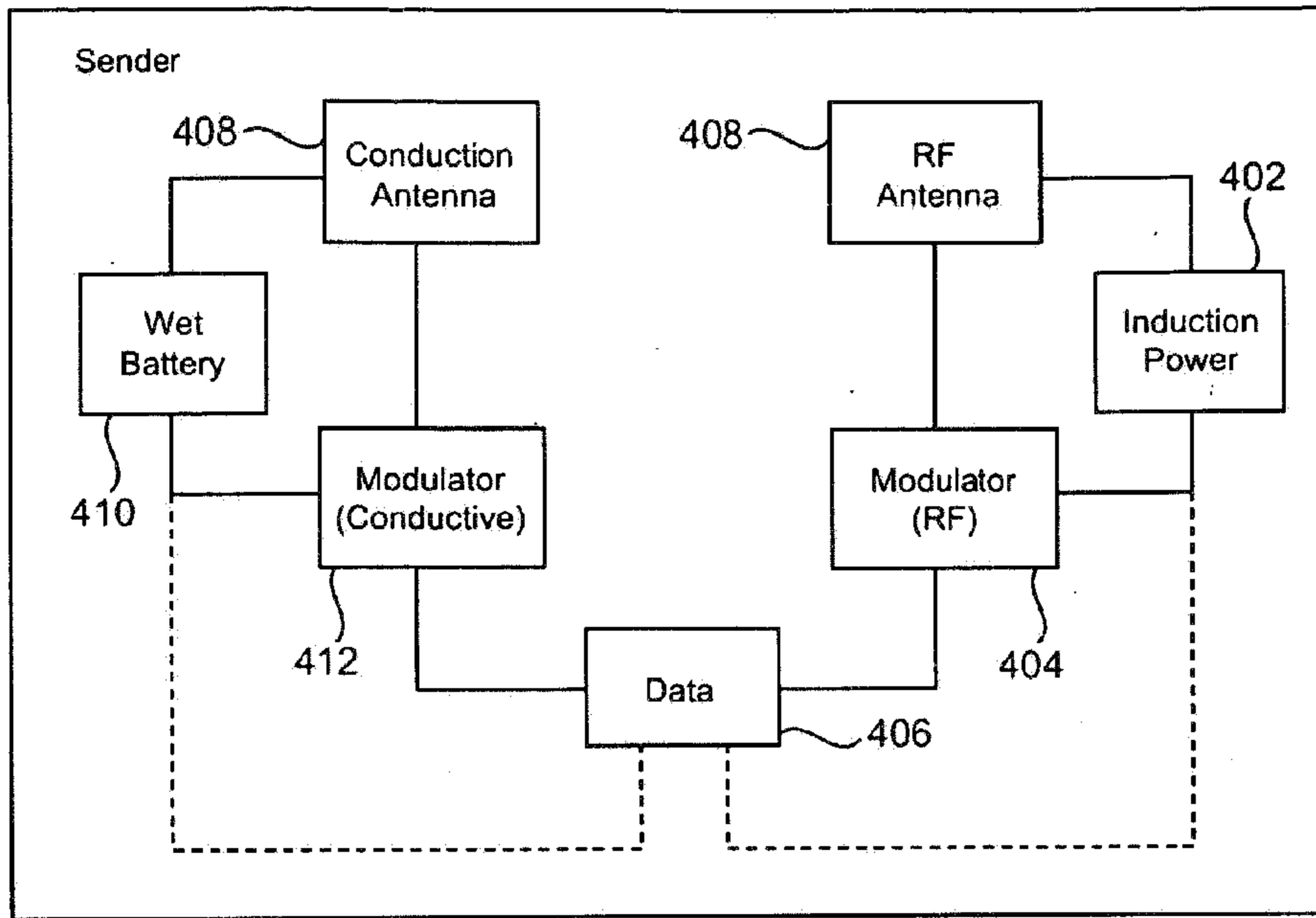

FIG. 5



400

FIG. 6

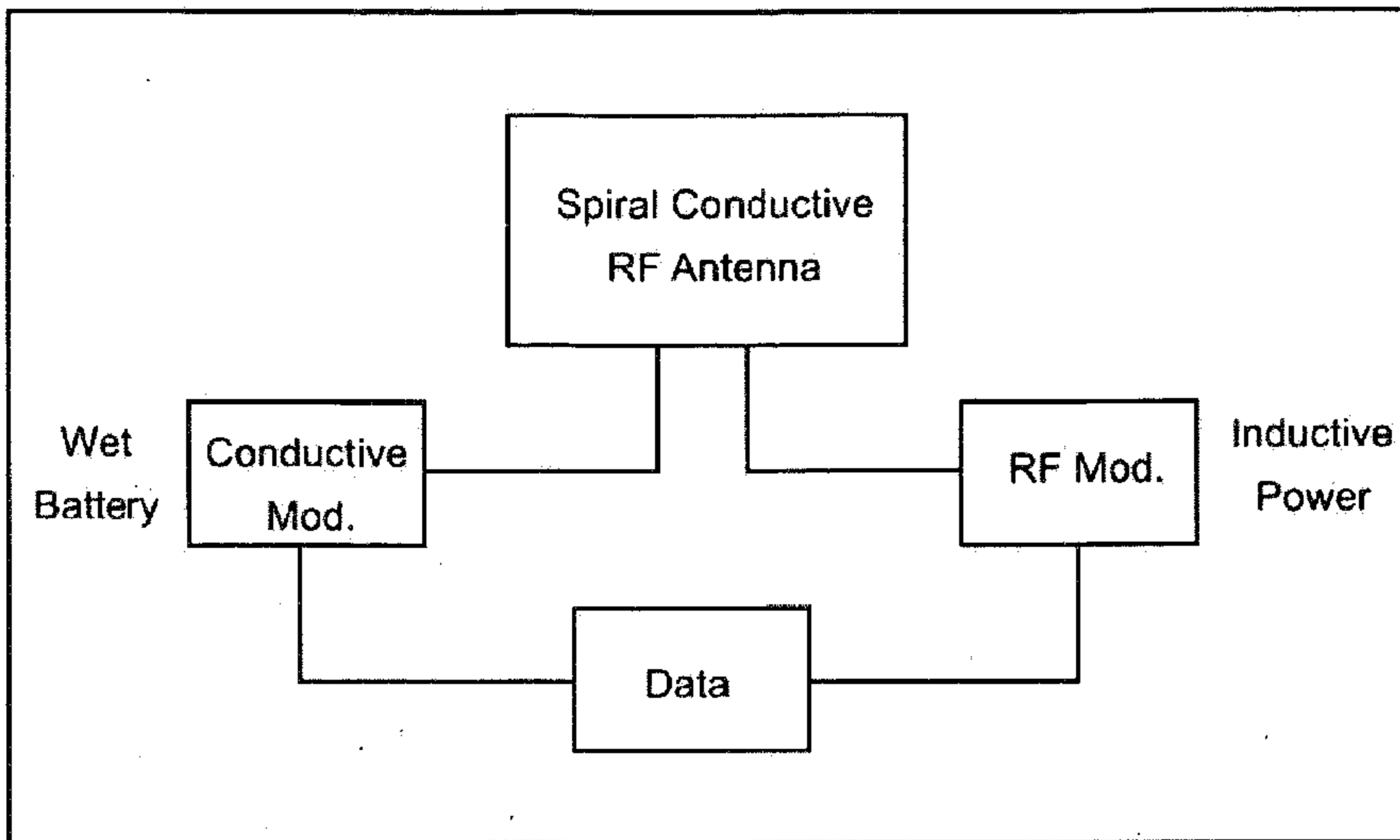
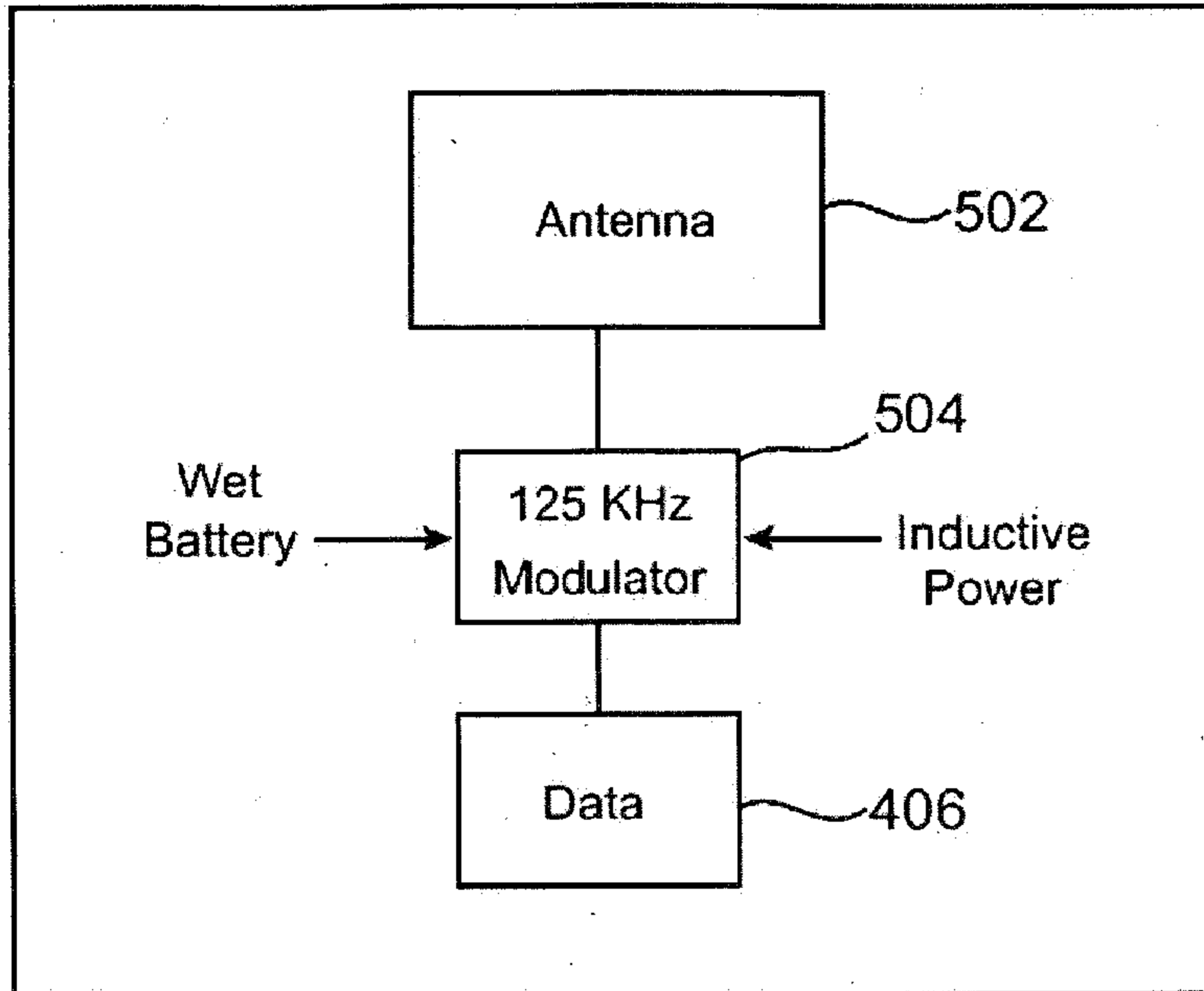

FIG. 7



500

FIGS. 8A and 8B

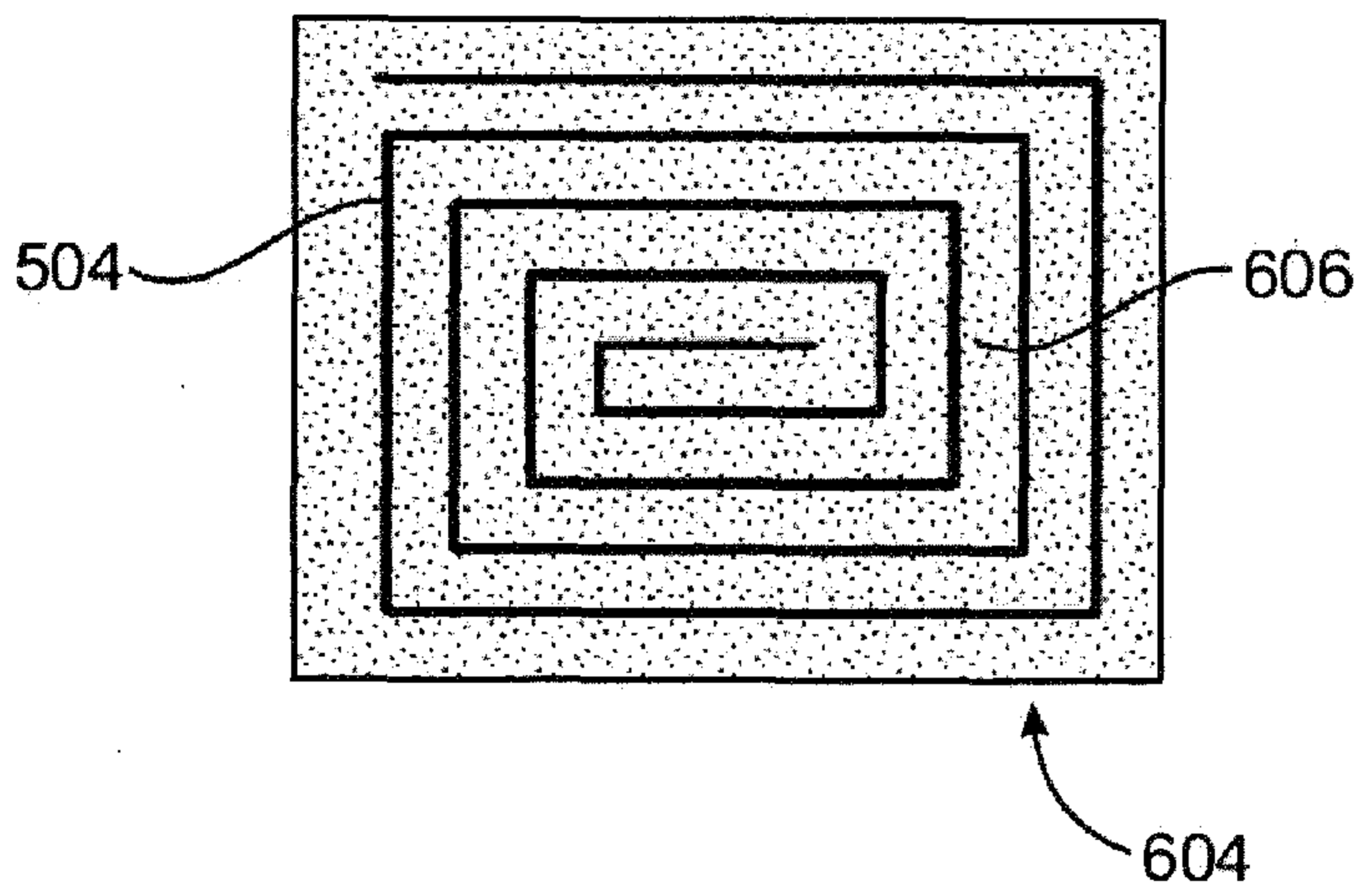
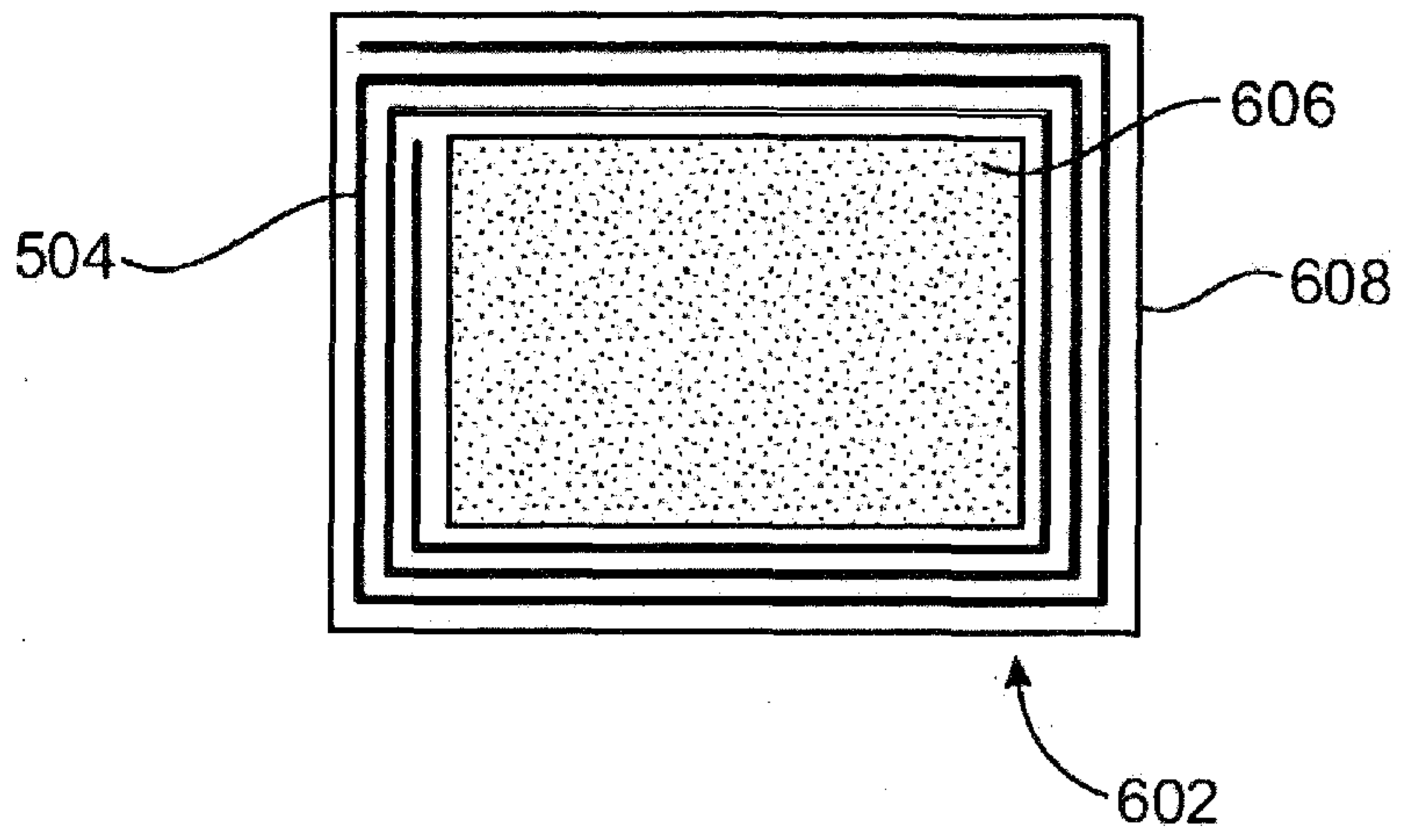

FIG. 9

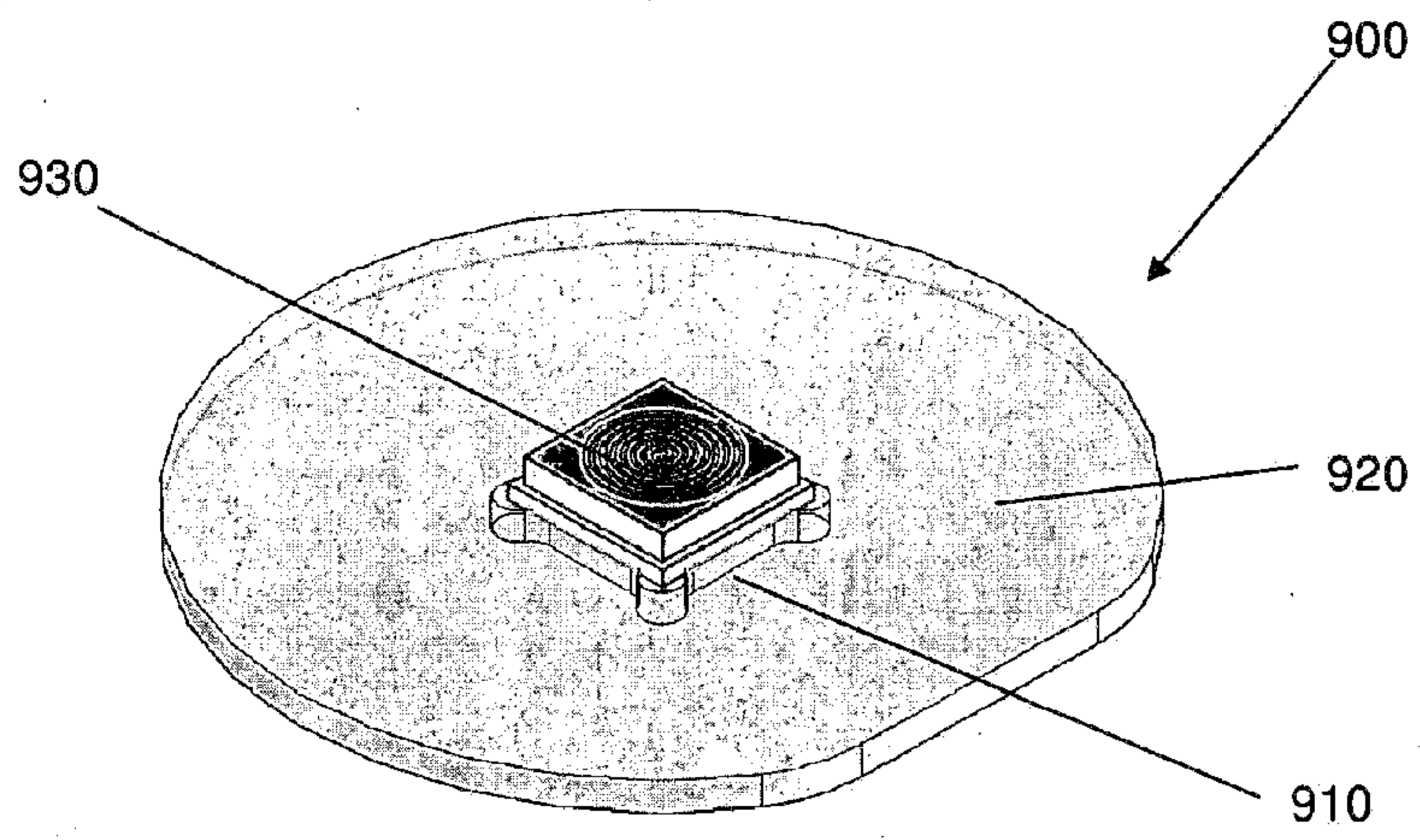
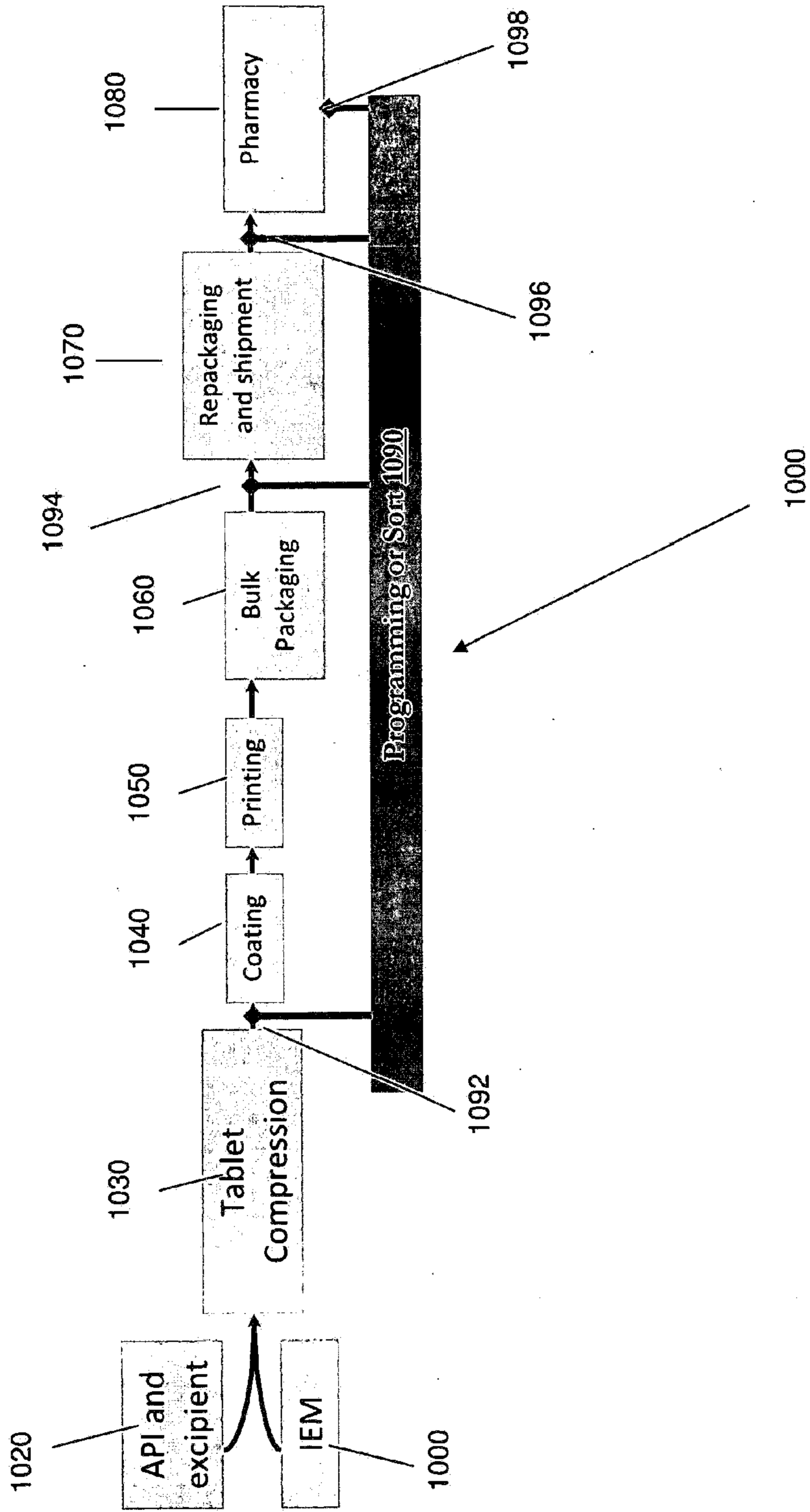

FIG. 10



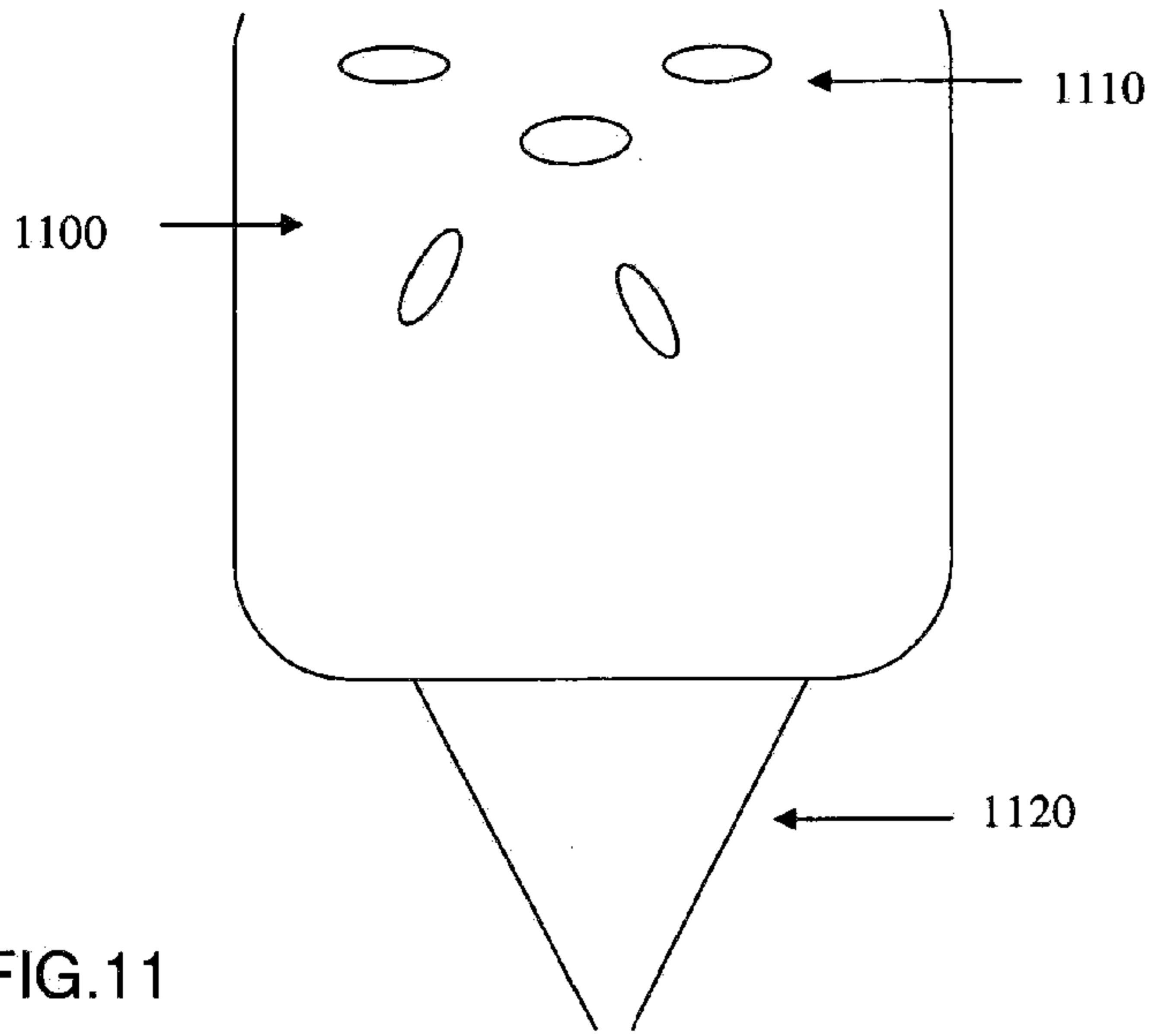

FIG. 11

RFID coils used  
Read ID's of IEM's as  
they fall through tube

(RFID coils connected  
to electronics and  
informatics system)

Informatics system  
records container ID  
with ID's of each  
IEM

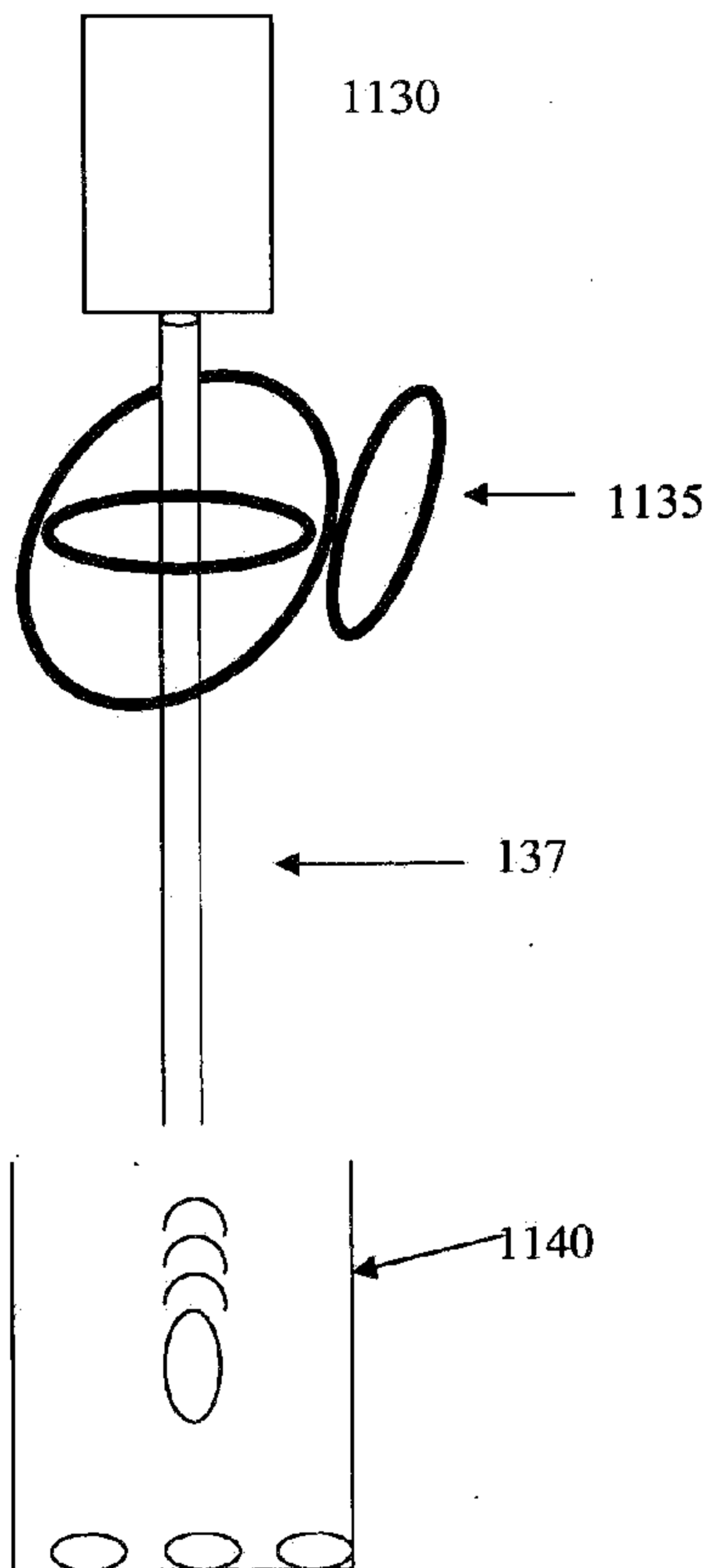

FIG. 12

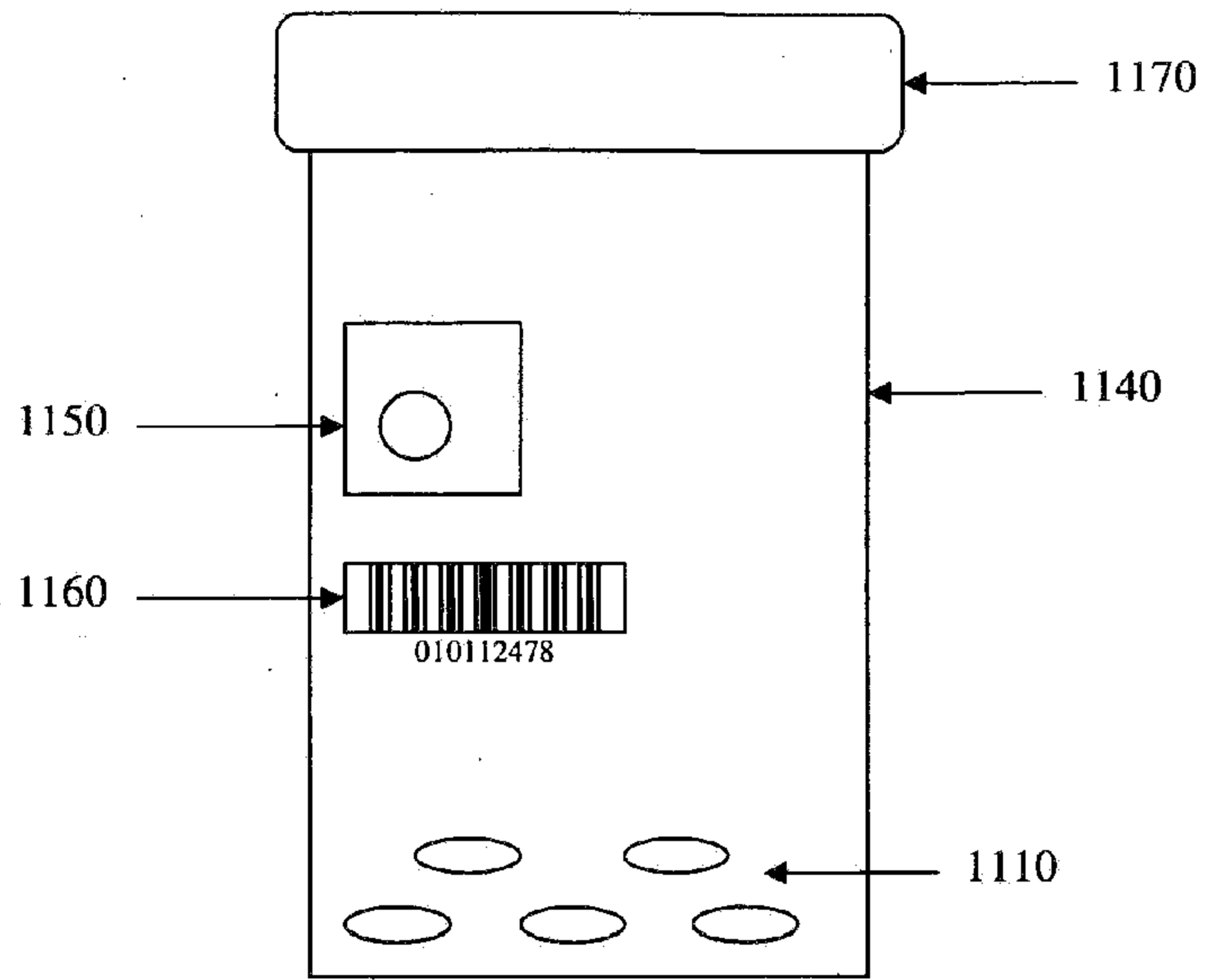

FIG. 13

