

(19) World Intellectual Property  
Organization  
International Bureau



(43) International Publication Date  
31 December 2003 (31.12.2003)

PCT

(10) International Publication Number  
**WO 2004/001501 A1**

- (51) International Patent Classification<sup>7</sup>: **G03B 19/02**, H04N 5/225, G06K 19/10
- (74) Agent: **SILVERBROOK, Kia**; Silverbrook Research Pty Ltd, 393 Darling Street, Balmain, NSW 2041 (AU).
- (21) International Application Number: PCT/AU2002/001161
- (81) Designated States (*national*): AE, AG, AL, AM, AT, AU, AZ, BA, BB, BG, BR, BY, BZ, CA, CH, CN, CO, CR, CU, CZ, DE, DK, DM, DZ, EC, EE, ES, FI, GB, GD, GE, GH, GM, HR, HU, ID, IL, IN, IS, JP, KE, KG, KP, KR, KZ, LC, LK, LR, LS, LT, LU, LV, MA, MD, MG, MK, MN, MW, MX, MZ, NO, NZ, OM, PH, PL, PT, RO, RU, SD, SE, SG, SI, SK, SL, TJ, TM, TN, TR, TT, TZ, UA, UG, US, UZ, VC, VN, YU, ZA, ZM, ZW.
- (22) International Filing Date: 29 August 2002 (29.08.2002)
- (25) Filing Language: English
- (84) Designated States (*regional*): ARIPO patent (GH, GM, KE, LS, MW, MZ, SD, SL, SZ, TZ, UG, ZM, ZW), Eurasian patent (AM, AZ, BY, KG, KZ, MD, RU, TJ, TM), European patent (AT, BE, BG, CH, CY, CZ, DE, DK, EE, ES, FI, FR, GB, GR, IE, IT, LU, MC, NL, PT, SE, SK, TR), OAPI patent (BF, BJ, CF, CG, CI, CM, GA, GN, GQ, GW, ML, MR, NE, SN, TD, TG).
- (26) Publication Language: English
- (30) Priority Data: 10/176,680 24 June 2002 (24.06.2002) US
- (71) Applicant (*for all designated States except US*): **SILVERBROOK RESEARCH PTY LTD** [AU/AU]; 393 Darling Street, Balmain, NSW 2041 (AU).
- (72) Inventor; and
- (75) Inventor/Applicant (*for US only*): **SILVERBROOK, Kia** [AU/AU]; Silverbrook Research Pty Ltd, 393 Darling Street, Balmain, NSW 2041 (AU).

Published:  
— with international search report

For two-letter codes and other abbreviations, refer to the "Guidance Notes on Codes and Abbreviations" appearing at the beginning of each regular issue of the PCT Gazette.

(54) Title: PHOTOGRAPHIC PRINTS HAVING MAGNETICALLY RECORDABLE MEDIA

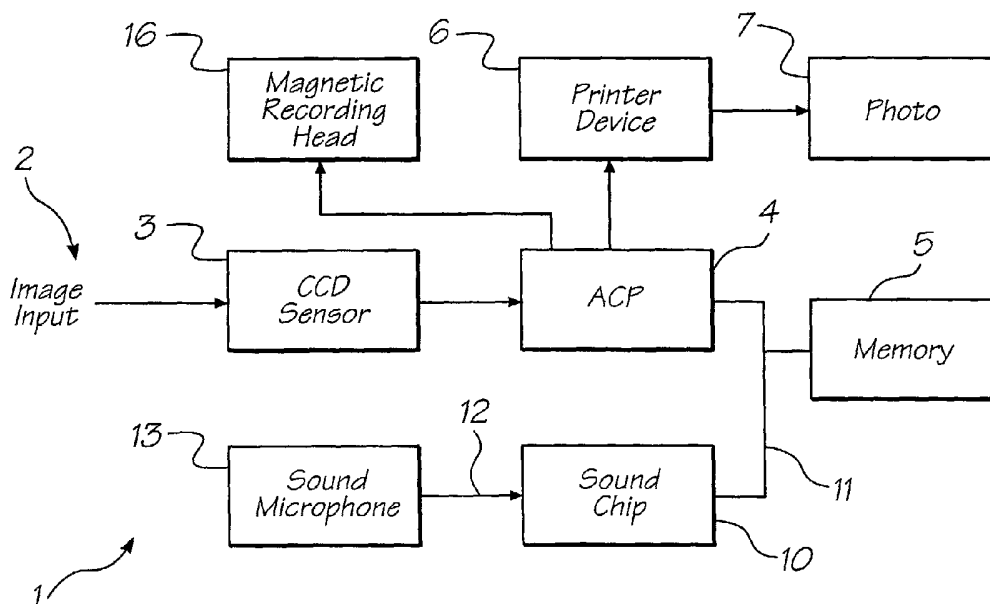

(57) Abstract: A camera provides a photo (7) printed on print media via printer device (6) under the control of a central processor (4). The photo (7) is a print of an image (5) provided by a CCD sensor (3). The photo (7) includes print media having, in addition, a magnetically recordable medium whereby sound processed by sound chip (10) received from sound microphone (13) and/or processed by central processor (4) can be recorded with magnetic recording head (16) on the photo (7). The photo (7) is printed using an ink jet printer on suitable ink jet compatible print media preferably with the magnetically recordable medium on the rear of the photo (7) and the image (2) on the front surface of the photo (7).

WO 2004/001501 A1

## PHOTOGRAPHIC PRINTS HAVING MAGNETICALLY RECORDABLE MEDIA

### FIELD OF THE INVENTION

5           The present invention relates to the field of digital image cameras and in particular, discloses a Camera and Media for Art Prints or Photos with Magnetically Recordable Feature.

### BACKGROUND OF THE INVENTION

10           The preferred embodiment is preferably implemented through modification of a hand held camera device such as that described in Patent Application USSN 09/113,060, which claims priority from Australian provisional application No. PO7991 entitled "Image Processing Method and Apparatus" (Art 01) filed 15 July, 1997.

          The aforementioned patent specification discloses a camera system, hereinafter  
15           known as an "Artcam" type camera, wherein sensed images can be directly printed out by an Artcam portable camera unit. Further, the aforementioned specification discloses means and methods for performing various manipulations on images captured by the camera sensing device leading to the production of various effects in any output image. The manipulations are disclosed to be highly flexible in nature and can be implemented through the insertion  
20           into the Artcam of cards having encoded thereon various instructions for the manipulation of images, the cards hereinafter being known as Artcards. The Artcam further has significant onboard processing power in an Artcam Central Processor unit (ACP) which is interconnected to a memory device for the storage of important data and images.

          The Artcam camera system which a digital camera with an inbuilt integral color  
25           printer. Additionally, the camera provides hardware and software for the increasing of the apparent resolution of the image sensing system and the conversion of the image to a wide range of "artistic styles" and a graphic enhancement.

          In one aspect, the Artcam camera system comprises at least one area image sensor for  
30           imaging a scene, a camera processor means for processing said imaged scene in accordance with a predetermined scene transformation requirement, a printer for printing out said processed image scene on print media, print media and printing ink stored in a single detachable module inside said camera system, said camera system comprising a portable hand

held unit for the imaging of scenes by said area image sensor and printing said scenes directly out of said camera system via said printer.

Preferably the camera system includes a print roll for the storage of print media and printing ink for utilization by the printer, the print roll being detachable from the camera system. Further, the print roll can include an authentication chip containing authentication information and the camera processing means is adapted to interrogate the authentication chip so as to determine the authenticity of said print roll when inserted within said camera system.

Further, the printer can include a drop on demand ink jet printer and guillotine means for the separation of printed photographs.

With such an arrangement, it would be desirable to be able to record ancillary information with each output photograph.

## **SUMMARY OF THE INVENTION**

It is an object of the present invention to provide for the magnetic recording of information such as audio with a photo output by an Artcam device.

In accordance with a first aspect of the present invention, there is provided a camera system for the creation of images, the camera system comprising a sensor for sensing an image; a processing means for processing the sensed image in accordance with predetermined processing requirements; a printer means for printing the sensed image on the surface of print media, the print media including a magnetically sensitive surface; a magnetic recording means for recording associated information on the magnetically sensitive surface.

The associated information can comprise audio information associated with the sensed image and the printer means preferably prints the sensed image on a first surface of the print media and the magnetic recording means records the associated information on a second surface of the print media. The print media can be stored on an internal detachable roll in the camera system. In one embodiment, the magnetic sensitive surface can comprise a strip affixed to the back surface of the print media.

In accordance with a second aspect of the present invention, there is provided a camera system for recording images, said camera system comprising:

an electronic image sensor for sensing an image;

a digital processing means for processing said sensed image in accordance with predetermined processing requirements;

a photo width ink jet printer means for printing said processed image on a surface of ink jet print media, said ink jet print media including a magnetic recording surface;

a magnetic recording means for recording associated information on said magnetic recording surface.

Preferably, said associated information comprises audio information associated with said sensed image.

Preferably, the printer means prints said sensed image on a first surface of said print media and the magnetic recording means records said associated information on a second surface of said print media. Preferably, said first and said second surfaces are on different faces of said print media.

Preferably, said ink jet print media is stored on an internal detachable roll in said camera system, said camera system comprising a hand held portable camera device, said photo width ink jet printer being built into said hand held portable camera device.

#### **BRIEF DESCRIPTION OF THE DRAWINGS**

Notwithstanding any other forms which may fall within the scope of the present invention, preferred forms of the invention will now be described, by way of example only, with reference to the accompanying drawings in which:

Fig. 1 illustrates schematically the camera system constructed in accordance to the preferred embodiment;

Fig. 2 illustrates schematically a printer mechanism and recording mechanism of the preferred embodiment.

Fig. 3 illustrates a format of the magnetic strip on the back of the photo;

Fig. 4 illustrates a reader device utilized to read data recorded on the back of a photograph; and

Fig. 5 illustrates the utilization of an apparatus of the preferred embodiment.

#### **DESCRIPTION OF PREFERRED AND OTHER EMBODIMENTS**

In the preferred embodiment a magnetic sensitive print media material is utilized for the recording of an audio message on the back of an output photograph. The Artcam device is

altered so as to include a magnetic recording device which can comprise an array of magnetic recorders covering a whole surface of the photograph or alternatively, a magnetic strip can be provided wherein, for example, a central portion of the photograph is magnetically sensitive. The Artcam devices are further provided with the ability to record an audio message for later  
5 playback.

The preferred embodiment is preferably implemented through suitable programming of a hand held camera device such as that described in Australian Provisional Patent Application No. PO7991 (USPN 09/113,060) entitled "Image Processing Method and Apparatus (Art 01)" filed 15 July, 1997.

10 The aforementioned patent specification discloses a camera system, hereinafter known as an "Artcam" type camera, wherein sensed images can be directly printed out by an Artcam portable camera unit. Further, the aforementioned specification discloses means and methods for performing various manipulations on images captured by the camera sensing device leading to the production of various effects in any output image. The manipulations  
15 are disclosed to be highly flexible in nature and can be implemented through the insertion into the Artcam of cards having encoded thereon various instructions for the manipulation of images, the cards hereinafter being known as Artcards. The Artcam further has significant onboard processing power by an Artcam Central Processor unit (ACP) which is interconnected to a memory device for the storage of important data and images.

20 In the preferred embodiment, the Artcam device is suitably modified so as to equip it with a microphone device and associated recording technologies. When a picture is taken, the opportunity is provided to record either the surrounding sound environment or a message associated with the image. The print media or film is pretreated so as to make it magnetically sensitive in a similar manner to that provided by tape media. The recording  
25 can be over the whole back surface of the output photo or alternatively a magnetically sensitive strip may be provided. The recorded audio is stored on the back of the output photograph in an encoded format, the encoding preferably being of a highly digital resilient form. The recorded audio provides a permanent audio record associated with the corresponding photograph. Subsequently, a playback apparatus is provided for scanning  
30 the encoded audio and decoding this information.

Turning now to Fig. 1, there is illustrated, in schematic form the preferred embodiment 1 which includes the arrangement as described in the aforementioned patent specification wherein an image 2 is sensed via a CCD sensor 3 and forwarded to an Artcam

central processor 4 which includes significant computational resources as described in the aforementioned patent specification. The Artcam central processor 4 can store the image in memory 5 which preferably comprises a high speed RAMBUS (Trade Mark) interfaced memory. The Artcam central processor 4 is also responsible for controlling the operation of a printhead 6 for the printing out of full colour photographs, eg. 7, so as to provide for instant images on demand in addition to the magnetic recording head 16, for recording on the back of the photo.

In the preferred embodiment, the camera arrangement 1 is also supplied with a sound chip 10 which interfaces via RAMBUS bus 11 to memory 5 under the control of the ACP processor 4. The sound chip 10 can be of a standard or specialised form and can, for example, comprise a DSP processor that takes an analogue input 12 from a sound microphone 13. Alternatively, with increasing chip complexities (Moore's Law), the functionality of sound chip 10 can be incorporated onto the ACP chip 4 which preferably comprises a leading edge CMOS type integrated circuit chip. It will be readily evident that many other types of arrangements can be provided which fall within the scope of the present invention.

The sound chip 10 converts the analogue input 12 to a corresponding digital form and forwards it for storage in memory 5. The recording process can be activated by means of the depressing of a button (not shown) on the camera device, the button being under the control of the ACP processor 4 otherwise it can be substantially automatic when taking a photo. The recorded data is stored in the memory 5.

Turning now to Fig. 2, the camera arrangement preferably includes a printer device 6 such as an ink jet printer which includes a printhead 6 to print an image on compatible print media 17 and a magnetic recording head 16. A further printhead can be used to print information on the back of print media 17. Similar arrangements for printing information on the back of an output photo image are described in USSN 09/112,741 (Art 12) the contents of which are hereby incorporated by cross reference.

Turning now to Fig. 3, there is illustrated an example of a magnetic strip 18 formed on the back of photo media 17, the strip being recorded on by recording head 16 of Fig. 1 or Fig. 2. The information recorded can include location, date and time data with the location data being provided by means of keyboard input or, alternatively, through the inclusion of a positioning systems such as GPS or the like. Fig 4 shows the back of the image 17 on which is also recorded an encoded form 22 of the audio information. The

format of the encoding can be any form within the knowledge of the person skilled in the art. However, preferably the encoding provides a highly fault tolerant form of encoding to tolerate errors that may arise due to use and handling of the print media. The encoding format can be, for example, Reed-Solomon encoding of the data to provide for a high  
5 degree of fault tolerance.

Turning to Fig. 4, when it is desired to “play back” the recorded audio, the photo 17 is passed through a reader device 26 which includes pinch rollers for guiding the photo 17 past a magnetic sensor device 27.

Referring now to Fig. 5, there is illustrated in schematic form the operation of the  
10 audio reader device 26 of Fig. 5. The magnetic sensor 27 is interconnected to a second Artcam central processor (ACP) 28 which is suitably adapted to read and decode the data stored on the back of the photograph. The decoded audio information is stored in memory 32 for playback via a sound processing chip 35 on speaker 29. The sound processing chip 35 can operate under the control of the ACP decoder 28 which in turn operates under the  
15 control of various user input controls 33 which can include volume controls, rewind, play and fast forward controls etc.

It can be seen from the foregoing description of the preferred embodiment that there is provided a system for the automatic recording of audio associated with an output image so as to provide an audio record associated with a photograph printed on ink jet media.  
20 There is also disclosed an audio reader system for reading an image recorded on the back of such a photograph.

It would be appreciated by a person skilled in the art that numerous variations and/or modifications any be made to the present invention as shown in the specific embodiment without departing from the spirit or scope of the invention as broadly  
25 described. For example, the utilisation of more complex audio recording and playback techniques such as stereo and B-format techniques. The present embodiment is, therefore, to be considered in all respects to be illustrative and not restrictive.

#### Ink Jet Technologies

The embodiments of the invention use an ink jet printer type device. Of course many  
30 different devices could be used. However presently popular ink jet printing technologies are unlikely to be suitable.

The most significant problem with thermal ink jet is power consumption. This is approximately 100 times that required for high speed, and stems from the energy-inefficient

means of drop ejection. This involves the rapid boiling of water to produce a vapor bubble which expels the ink. Water has a very high heat capacity, and must be superheated in thermal ink jet applications. This leads to an efficiency of around 0.02%, from electricity input to drop momentum (and increased surface area) out.

- 5           The most significant problem with piezoelectric ink jet is size and cost. Piezoelectric crystals have a very small deflection at reasonable drive voltages, and therefore require a large area for each nozzle. Also, each piezoelectric actuator must be connected to its drive circuit on a separate substrate. This is not a significant problem at the current limit of around 300 nozzles per print head, but is a major impediment to the
- 10       fabrication of pagewide print heads with 19,200 nozzles.

Ideally, the ink jet technologies used meet the stringent requirements of in-camera digital color printing and other high quality, high speed, low cost printing applications. To meet the requirements of digital photography, new ink jet technologies have been created. The target features include:

- 15           low power (less than 10 Watts)  
              high resolution capability (1,600 dpi or more)  
              photographic quality output  
              low manufacturing cost  
              small size (pagewidth times minimum cross section)
- 20           high speed (< 2 seconds per page).

- All of these features can be met or exceeded by the ink jet systems described below with differing levels of difficulty. 45 different ink jet technologies have been developed by the Assignee to give a wide range of choices for high volume manufacture. These technologies form part of separate applications assigned to the present Assignee as set out in the table
- 25       below..

The ink jet designs shown here are suitable for a wide range of digital printing systems, from battery powered one-time use digital cameras, through to desktop and network printers, and through to commercial printing systems.

- For ease of manufacture using standard process equipment, the print head is designed
- 30       to be a monolithic 0.5 micron CMOS chip with MEMS post processing. For color photographic applications, the print head is 100 mm long, with a width which depends upon the ink jet type. The smallest print head designed is IJ38, which is 0.35 mm wide, giving a chip area of 35 square mm. The print heads each contain 19,200 nozzles plus data and control



circuitry.

Ink is supplied to the back of the print head by injection molded plastic ink channels. The molding requires 50 micron features, which can be created using a lithographically micromachined insert in a standard injection molding tool. Ink flows through holes etched  
5 through the wafer to the nozzle chambers fabricated on the front surface of the wafer. The print head is connected to the camera circuitry by tape automated bonding.

#### Tables of Drop-on-Demand Ink Jets

Eleven important characteristics of the fundamental operation of individual ink jet nozzles have been identified. These characteristics are largely orthogonal, and so can be  
10 elucidated as an eleven dimensional matrix. Most of the eleven axes of this matrix include entries developed by the present assignee.

The following tables form the axes of an eleven dimensional table of ink jet types.

- Actuator mechanism (18 types)
- Basic operation mode (7 types)
- 15 Auxiliary mechanism (8 types)
- Actuator amplification or modification method (17 types)
- Actuator motion (19 types)
- Nozzle refill method (4 types)
- Method of restricting back-flow through inlet (10 types)
- 20 Nozzle clearing method (9 types)
- Nozzle plate construction (9 types)
- Drop ejection direction (5 types)
- Ink type (7 types)

The complete eleven dimensional table represented by these axes contains 36.9  
25 billion possible configurations of ink jet nozzle. While not all of the possible combinations result in a viable ink jet technology, many million configurations are viable. It is clearly impractical to elucidate all of the possible configurations. Instead, certain ink jet types have been investigated in detail. These are designated IJ01 to IJ45 above.

Other ink jet configurations can readily be derived from these 45 examples by  
30 substituting alternative configurations along one or more of the 11 axes. Most of the IJ01 to IJ45 examples can be made into ink jet print heads with characteristics superior to any currently available ink jet technology.

Where there are prior art examples known to the inventor, one or more of these

examples are listed in the examples column of the tables below. The IJ01 to IJ45 series are also listed in the examples column. In some cases, a printer may be listed more than once in a table, where it shares characteristics with more than one entry.

5 Suitable applications for the ink jet technologies include: Home printers, Office network printers, Short run digital printers, Commercial print systems, Fabric printers, Pocket printers, Internet WWW printers, Video printers, Medical imaging, Wide format printers, Notebook PC printers, Fax machines, Industrial printing systems, Photocopiers, Photographic minilabs etc.

10 The information associated with the aforementioned 11 dimensional matrix are set out in the following tables.

ACTUATOR MECHANISM (APPLIED ONLY TO SELECTED INK DROPS)				
	Description	Advantages	Disadvantages	Examples
<b>Thermal bubble</b>	<p>An electrothermal heater heats the ink to above boiling point, transferring significant heat to the aqueous ink. A bubble nucleates and quickly forms, expelling the ink.</p> <p>The efficiency of the process is low, with typically less than 0.05% of the electrical energy being transformed into kinetic energy of the drop.</p>	<ul style="list-style-type: none"> <li>◆ Large force generated</li> <li>◆ Simple construction</li> <li>◆ No moving parts</li> <li>◆ Fast operation</li> <li>◆ Small chip area required for actuator</li> </ul>	<ul style="list-style-type: none"> <li>◆ High power</li> <li>◆ Ink carrier limited to water</li> <li>◆ Low efficiency</li> <li>◆ High temperatures required</li> <li>◆ High mechanical stress</li> <li>◆ Unusual materials required</li> <li>◆ Large drive transistors</li> <li>◆ Cavitation causes actuator failure</li> <li>◆ Kogation reduces bubble formation</li> <li>◆ Large print heads are difficult to fabricate</li> </ul>	<ul style="list-style-type: none"> <li>◆ Canon Bubblejet 1979 Endo et al GB patent 2,007,162</li> <li>◆ Xerox heater-in-pit 1990 Hawkins et al USP 4,899,181</li> <li>◆ Hewlett-Packard TIJ 1982 Vaught et al USP 4,490,728</li> </ul>
<b>Piezo-electric</b>	<p>A piezoelectric crystal such as lead lanthanum zirconate (PZT) is electrically activated, and either expands, shears, or bends to apply pressure to the ink, ejecting drops.</p>	<ul style="list-style-type: none"> <li>◆ Low power consumption</li> <li>◆ Many ink types can be used</li> <li>◆ Fast operation</li> <li>◆ High efficiency</li> </ul>	<ul style="list-style-type: none"> <li>◆ Very large area required for actuator</li> <li>◆ Difficult to integrate with electronics</li> <li>◆ High voltage drive transistors required</li> <li>◆ Full pagewidth print heads impractical due to actuator size</li> <li>◆ Requires electrical poling in high field strengths during manufacture</li> </ul>	<ul style="list-style-type: none"> <li>◆ Kyser et al USP 3,946,398</li> <li>◆ Zoltan USP 3,683,212</li> <li>◆ 1973 Stemme USP 3,747,120</li> <li>◆ Epson Stylus</li> <li>◆ Tektronix</li> <li>◆ IJ04</li> </ul>
<b>Electro-strictive</b>	<p>An electric field is used to activate electrostriction in relaxor materials such as lead lanthanum zirconate titanate (PLZT) or lead magnesium niobate (PMN).</p>	<ul style="list-style-type: none"> <li>◆ Low power consumption</li> <li>◆ Many ink types can be used</li> <li>◆ Low thermal expansion</li> <li>◆ Electric field strength required (approx. 3.5 V/<math>\mu\text{m}</math>) can be generated without difficulty</li> <li>◆ Does not require electrical poling</li> </ul>	<ul style="list-style-type: none"> <li>◆ Low maximum strain (approx. 0.01%)</li> <li>◆ Large area required for actuator due to low strain</li> <li>◆ Response speed is marginal (<math>\sim 10 \mu\text{s}</math>)</li> <li>◆ High voltage drive transistors required</li> <li>◆ Full pagewidth print heads impractical due to actuator size</li> </ul>	<ul style="list-style-type: none"> <li>◆ Seiko Epson, Usui et al JP 253401/96</li> <li>◆ IJ04</li> </ul>

ACTUATOR MECHANISM (APPLIED ONLY TO SELECTED INK DROPS)				
	Description	Advantages	Disadvantages	Examples
<b>Ferro-electric</b>	An electric field is used to induce a phase transition between the antiferroelectric (AFE) and ferroelectric (FE) phase. Perovskite materials such as tin modified lead lanthanum zirconate titanate (PLZSnT) exhibit large strains of up to 1% associated with the AFE to FE phase transition.	<ul style="list-style-type: none"> <li>◆ Low power consumption</li> <li>◆ Many ink types can be used</li> <li>◆ Fast operation (&lt; 1 <math>\mu</math>s)</li> <li>◆ Relatively high longitudinal strain</li> <li>◆ High efficiency</li> <li>◆ Electric field strength of around 3 V/<math>\mu</math>m can be readily provided</li> </ul>	<ul style="list-style-type: none"> <li>◆ Difficult to integrate with electronics</li> <li>◆ Unusual materials such as PLZSnT are required</li> <li>◆ Actuators require a large area</li> </ul>	<ul style="list-style-type: none"> <li>◆ IJ04</li> </ul>
<b>Electro-static plates</b>	Conductive plates are separated by a compressible or fluid dielectric (usually air). Upon application of a voltage, the plates attract each other and displace ink, causing drop ejection. The conductive plates may be in a comb or honeycomb structure, or stacked to increase the surface area and therefore the force.	<ul style="list-style-type: none"> <li>◆ Low power consumption</li> <li>◆ Many ink types can be used</li> <li>◆ Fast operation</li> </ul>	<ul style="list-style-type: none"> <li>◆ Difficult to operate electrostatic devices in an aqueous environment</li> <li>◆ The electrostatic actuator will normally need to be separated from the ink</li> <li>◆ Very large area required to achieve high forces</li> <li>◆ High voltage drive transistors may be required</li> <li>◆ Full pagewidth print heads are not competitive due to actuator size</li> </ul>	<ul style="list-style-type: none"> <li>◆ IJ02, IJ04</li> </ul>
<b>Electro-static pull on ink</b>	A strong electric field is applied to the ink, whereupon electrostatic attraction accelerates the ink towards the print medium.	<ul style="list-style-type: none"> <li>◆ Low current consumption</li> <li>◆ Low temperature</li> </ul>	<ul style="list-style-type: none"> <li>◆ High voltage required</li> <li>◆ May be damaged by sparks due to air breakdown</li> <li>◆ Required field strength increases as the drop size decreases</li> <li>◆ High voltage drive transistors required</li> <li>◆ Electrostatic field attracts dust</li> </ul>	<ul style="list-style-type: none"> <li>◆ 1989 Saito et al, USP 4,799,068</li> <li>◆ 1989 Miura et al, USP 4,810,954</li> <li>◆ Tone-jet</li> </ul>

ACTUATOR MECHANISM (APPLIED ONLY TO SELECTED INK DROPS)				
	Description	Advantages	Disadvantages	Examples
<b>Permanent magnet electro-magnetic</b>	An electromagnet directly attracts a permanent magnet, displacing ink and causing drop ejection. Rare earth magnets with a field strength around 1 Tesla can be used. Examples are: Samarium Cobalt (SaCo) and magnetic materials in the neodymium iron boron family (NdFeB, NdDyFeBNb, NdDyFeB, etc)	<ul style="list-style-type: none"> <li>◆ Low power consumption</li> <li>◆ Many ink types can be used</li> <li>◆ Fast operation</li> <li>◆ High efficiency</li> <li>◆ Easy extension from single nozzles to pagewidth print heads</li> </ul>	<ul style="list-style-type: none"> <li>◆ Complex fabrication</li> <li>◆ Permanent magnetic material such as Neodymium Iron Boron (NdFeB) required.</li> <li>◆ High local currents required</li> <li>◆ Copper metalization should be used for long electromigration lifetime and low resistivity</li> <li>◆ Pigmented inks are usually infeasible</li> <li>◆ Operating temperature limited to the Curie temperature (around 540 K)</li> </ul>	<ul style="list-style-type: none"> <li>◆ IJ07, IJ10</li> </ul>
<b>Soft magnetic core electro-magnetic</b>	A solenoid induced a magnetic field in a soft magnetic core or yoke fabricated from a ferrous material such as electroplated iron alloys such as CoNiFe [1], CoFe, or NiFe alloys. Typically, the soft magnetic material is in two parts, which are normally held apart by a spring. When the solenoid is actuated, the two parts attract, displacing the ink.	<ul style="list-style-type: none"> <li>◆ Low power consumption</li> <li>◆ Many ink types can be used</li> <li>◆ Fast operation</li> <li>◆ High efficiency</li> <li>◆ Easy extension from single nozzles to pagewidth print heads</li> <li>◆</li> </ul>	<ul style="list-style-type: none"> <li>◆ Complex fabrication</li> <li>◆ Materials not usually present in a CMOS fab such as NiFe, CoNiFe, or CoFe are required</li> <li>◆ High local currents required</li> <li>◆ Copper metalization should be used for long electromigration lifetime and low resistivity</li> <li>◆ Electroplating is required</li> <li>◆ High saturation flux density is required (2.0-2.1 T is achievable with CoNiFe [1])</li> </ul>	<ul style="list-style-type: none"> <li>◆ IJ01, IJ05, IJ08, IJ10, IJ12, IJ14, IJ15, IJ17</li> </ul>

ACTUATOR MECHANISM (APPLIED ONLY TO SELECTED INK DROPS)				
	Description	Advantages	Disadvantages	Examples
<b>Lorenz force</b>	<p>The Lorenz force acting on a current carrying wire in a magnetic field is utilized.</p> <p>This allows the magnetic field to be supplied externally to the print head, for example with rare earth permanent magnets.</p> <p>Only the current carrying wire need be fabricated on the print-head, simplifying materials requirements.</p>	<ul style="list-style-type: none"> <li>◆ Low power consumption</li> <li>◆ Many ink types can be used</li> <li>◆ Fast operation</li> <li>◆ High efficiency</li> <li>◆ Easy extension from single nozzles to pagewidth print heads</li> </ul>	<ul style="list-style-type: none"> <li>◆ Force acts as a twisting motion</li> <li>◆ Typically, only a quarter of the solenoid length provides force in a useful direction</li> <li>◆ High local currents required</li> <li>◆ Copper metalization should be used for long electromigration lifetime and low resistivity</li> <li>◆ Pigmented inks are usually infeasible</li> </ul>	<ul style="list-style-type: none"> <li>◆ IJ06, IJ11, IJ13, IJ16</li> </ul>
<b>Magnetostriction</b>	<p>The actuator uses the giant magnetostrictive effect of materials such as Terfenol-D (an alloy of terbium, dysprosium and iron developed at the Naval Ordnance Laboratory, hence Ter-Fe-NOL). For best efficiency, the actuator should be pre-stressed to approx. 8 MPa.</p>	<ul style="list-style-type: none"> <li>◆ Many ink types can be used</li> <li>◆ Fast operation</li> <li>◆ Easy extension from single nozzles to pagewidth print heads</li> <li>◆ High force is available</li> </ul>	<ul style="list-style-type: none"> <li>◆ Force acts as a twisting motion</li> <li>◆ Unusual materials such as Terfenol-D are required</li> <li>◆ High local currents required</li> <li>◆ Copper metalization should be used for long electromigration lifetime and low resistivity</li> <li>◆ Pre-stressing may be required</li> </ul>	<ul style="list-style-type: none"> <li>◆ Fischenbeck, USP 4,032,929</li> <li>◆ IJ25</li> </ul>
<b>Surface tension reduction</b>	<p>Ink under positive pressure is held in a nozzle by surface tension. The surface tension of the ink is reduced below the bubble threshold, causing the ink to egress from the nozzle.</p>	<ul style="list-style-type: none"> <li>◆ Low power consumption</li> <li>◆ Simple construction</li> <li>◆ No unusual materials required in fabrication</li> <li>◆ High efficiency</li> <li>◆ Easy extension from single nozzles to pagewidth print heads</li> </ul>	<ul style="list-style-type: none"> <li>◆ Requires supplementary force to effect drop separation</li> <li>◆ Requires special ink surfactants</li> <li>◆ Speed may be limited by surfactant properties</li> </ul>	<ul style="list-style-type: none"> <li>◆ Silverbrook, EP 0771 658 A2 and related patent applications</li> </ul>

<b>ACTUATOR MECHANISM (APPLIED ONLY TO SELECTED INK DROPS)</b>				
	<b>Description</b>	<b>Advantages</b>	<b>Disadvantages</b>	<b>Examples</b>
<b>Viscosity reduction</b>	The ink viscosity is locally reduced to select which drops are to be ejected. A viscosity reduction can be achieved electrothermally with most inks, but special inks can be engineered for a 100:1 viscosity reduction.	<ul style="list-style-type: none"> <li>◆ Simple construction</li> <li>◆ No unusual materials required in fabrication</li> <li>◆ Easy extension from single nozzles to pagewidth print heads</li> </ul>	<ul style="list-style-type: none"> <li>◆ Requires supplementary force to effect drop separation</li> <li>◆ Requires special ink viscosity properties</li> <li>◆ High speed is difficult to achieve</li> <li>◆ Requires oscillating ink pressure</li> <li>◆ A high temperature difference (typically 80 degrees) is required</li> </ul>	<ul style="list-style-type: none"> <li>◆ Silverbrook, EP 0771 658 A2 and related patent applications</li> </ul>
<b>Acoustic</b>	An acoustic wave is generated and focussed upon the drop ejection region.	<ul style="list-style-type: none"> <li>◆ Can operate without a nozzle plate</li> </ul>	<ul style="list-style-type: none"> <li>◆ Complex drive circuitry</li> <li>◆ Complex fabrication</li> <li>◆ Low efficiency</li> <li>◆ Poor control of drop position</li> <li>◆ Poor control of drop volume</li> </ul>	<ul style="list-style-type: none"> <li>◆ 1993 Hadimioglu et al, EUP 550,192</li> <li>◆ 1993 Elrod et al, EUP 572,220</li> </ul>
<b>Thermo-elastic bend actuator</b>	An actuator which relies upon differential thermal expansion upon Joule heating is used.	<ul style="list-style-type: none"> <li>◆ Low power consumption</li> <li>◆ Many ink types can be used</li> <li>◆ Simple planar fabrication</li> <li>◆ Small chip area required for each actuator</li> <li>◆ Fast operation</li> <li>◆ High efficiency</li> <li>◆ CMOS compatible voltages and currents</li> <li>◆ Standard MEMS processes can be used</li> <li>◆ Easy extension from single nozzles to pagewidth print heads</li> </ul>	<ul style="list-style-type: none"> <li>◆ Efficient aqueous operation requires a thermal insulator on the hot side</li> <li>◆ Corrosion prevention can be difficult</li> <li>◆ Pigmented inks may be infeasible, as pigment particles may jam the bend actuator</li> </ul>	<ul style="list-style-type: none"> <li>◆ IJ03, IJ09, IJ17, IJ18, IJ19, IJ20, IJ21, IJ22, IJ23, IJ24, IJ27, IJ28, IJ29, IJ30, IJ31, IJ32, IJ33, IJ34, IJ35, IJ36, IJ37, IJ38, IJ39, IJ40, IJ41</li> </ul>

ACTUATOR MECHANISM (APPLIED ONLY TO SELECTED INK DROPS)				
	Description	Advantages	Disadvantages	Examples
<b>High CTE thermo-elastic actuator</b>	<p>A material with a very high coefficient of thermal expansion (CTE) such as polytetrafluoroethylene (PTFE) is used. As high CTE materials are usually non-conductive, a heater fabricated from a conductive material is incorporated. A 50 <math>\mu\text{m}</math> long PTFE bend actuator with polysilicon heater and 15 mW power input can provide 180 <math>\mu\text{N}</math> force and 10 <math>\mu\text{m}</math> deflection. Actuator motions include:</p> <p>Bend Push Buckle Rotate</p>	<ul style="list-style-type: none"> <li>◆ High force can be generated</li> <li>◆ Three methods of PTFE deposition are under development: chemical vapor deposition (CVD), spin coating, and evaporation</li> <li>◆ PTFE is a candidate for low dielectric constant insulation in ULSI</li> <li>◆ Very low power consumption</li> <li>◆ Many ink types can be used</li> <li>◆ Simple planar fabrication</li> <li>◆ Small chip area required for each actuator</li> <li>◆ Fast operation</li> <li>◆ High efficiency</li> <li>◆ CMOS compatible voltages and currents</li> <li>◆ Easy extension from single nozzles to pagewidth print heads</li> </ul>	<ul style="list-style-type: none"> <li>◆ Requires special material (e.g. PTFE)</li> <li>◆ Requires a PTFE deposition process, which is not yet standard in ULSI fabs</li> <li>◆ PTFE deposition cannot be followed with high temperature (above 350 °C) processing</li> <li>◆ Pigmented inks may be infeasible, as pigment particles may jam the bend actuator</li> </ul>	<ul style="list-style-type: none"> <li>◆ IJ09, IJ17, IJ18, IJ20, IJ21, IJ22, IJ23, IJ24, IJ27, IJ28, IJ29, IJ30, IJ31, IJ42, IJ43, IJ44</li> </ul>
<b>Conduct-ive polymer thermo-elastic actuator</b>	<p>A polymer with a high coefficient of thermal expansion (such as PTFE) is doped with conducting substances to increase its conductivity to about 3 orders of magnitude below that of copper. The conducting polymer expands when resistively heated.</p> <p>Examples of conducting dopants include:</p> <p>Carbon nanotubes Metal fibers Conductive polymers such as doped polythiophene Carbon granules</p>	<ul style="list-style-type: none"> <li>◆ High force can be generated</li> <li>◆ Very low power consumption</li> <li>◆ Many ink types can be used</li> <li>◆ Simple planar fabrication</li> <li>◆ Small chip area required for each actuator</li> <li>◆ Fast operation</li> <li>◆ High efficiency</li> <li>◆ CMOS compatible voltages and currents</li> <li>◆ Easy extension from single nozzles to pagewidth print heads</li> </ul>	<ul style="list-style-type: none"> <li>◆ Requires special materials development (High CTE conductive polymer)</li> <li>◆ Requires a PTFE deposition process, which is not yet standard in ULSI fabs</li> <li>◆ PTFE deposition cannot be followed with high temperature (above 350 °C) processing</li> <li>◆ Evaporation and CVD deposition techniques cannot be used</li> <li>◆ Pigmented inks may be infeasible, as pigment particles may jam the bend actuator</li> </ul>	<ul style="list-style-type: none"> <li>◆ IJ24</li> </ul>



ACTUATOR MECHANISM (APPLIED ONLY TO SELECTED INK DROPS)				
	Description	Advantages	Disadvantages	Examples
<b>Shape memory alloy</b>	A shape memory alloy such as TiNi (also known as Nitinol - Nickel Titanium alloy developed at the Naval Ordnance Laboratory) is thermally switched between its weak martensitic state and its high stiffness austenitic state. The shape of the actuator in its martensitic state is deformed relative to the austenitic shape. The shape change causes ejection of a drop.	<ul style="list-style-type: none"> <li>◆ High force is available (stresses of hundreds of MPa)</li> <li>◆ Large strain is available (more than 3%)</li> <li>◆ High corrosion resistance</li> <li>◆ Simple construction</li> <li>◆ Easy extension from single nozzles to pagewidth print heads</li> <li>◆ Low voltage operation</li> </ul>	<ul style="list-style-type: none"> <li>◆ Fatigue limits maximum number of cycles</li> <li>◆ Low strain (1%) is required to extend fatigue resistance</li> <li>◆ Cycle rate limited by heat removal</li> <li>◆ Requires unusual materials (TiNi)</li> <li>◆ The latent heat of transformation must be provided</li> <li>◆ High current operation</li> <li>◆ Requires pre-stressing to distort the martensitic state</li> </ul>	<ul style="list-style-type: none"> <li>◆ IJ26</li> </ul>
<b>Linear Magnetic Actuator</b>	Linear magnetic actuators include the Linear Induction Actuator (LIA), Linear Permanent Magnet Synchronous Actuator (LPMSA), Linear Reluctance Synchronous Actuator (LRSA), Linear Switched Reluctance Actuator (LSRA), and the Linear Stepper Actuator (LSA).	<ul style="list-style-type: none"> <li>◆ Linear Magnetic actuators can be constructed with high thrust, long travel, and high efficiency using planar semiconductor fabrication techniques</li> <li>◆ Long actuator travel is available</li> <li>◆ Medium force is available</li> <li>◆ Low voltage operation</li> </ul>	<ul style="list-style-type: none"> <li>◆ Requires unusual semiconductor materials such as soft magnetic alloys (e.g. CoNiFe)</li> <li>◆ Some varieties also require permanent magnetic materials such as Neodymium iron boron (NdFeB)</li> <li>◆ Requires complex multi-phase drive circuitry</li> <li>◆ High current operation</li> </ul>	<ul style="list-style-type: none"> <li>◆ IJ12</li> </ul>

BASIC OPERATION MODE				
	Description	Advantages	Disadvantages	Examples

BASIC OPERATION MODE				
	Description	Advantages	Disadvantages	Examples
<b>Actuator directly pushes ink</b>	This is the simplest mode of operation: the actuator directly supplies sufficient kinetic energy to expel the drop. The drop must have a sufficient velocity to overcome the surface tension.	<ul style="list-style-type: none"> <li>◆ Simple operation</li> <li>◆ No external fields required</li> <li>◆ Satellite drops can be avoided if drop velocity is less than 4 m/s</li> <li>◆ Can be efficient, depending upon the actuator used</li> </ul>	<ul style="list-style-type: none"> <li>◆ Drop repetition rate is usually limited to around 10 kHz. However, this is not fundamental to the method, but is related to the refill method normally used</li> <li>◆ All of the drop kinetic energy must be provided by the actuator</li> <li>◆ Satellite drops usually form if drop velocity is greater than 4.5 m/s</li> </ul>	<ul style="list-style-type: none"> <li>◆ Thermal ink jet</li> <li>◆ Piezoelectric ink jet</li> <li>◆ IJ01, IJ02, IJ03, IJ04, IJ05, IJ06, IJ07, IJ09, IJ11, IJ12, IJ14, IJ16, IJ20, IJ22, IJ23, IJ24, IJ25, IJ26, IJ27, IJ28, IJ29, IJ30, IJ31, IJ32, IJ33, IJ34, IJ35, IJ36, IJ37, IJ38, IJ39, IJ40, IJ41, IJ42, IJ43, IJ44</li> </ul>
<b>Proximity</b>	The drops to be printed are selected by some manner (e.g. thermally induced surface tension reduction of pressurized ink). Selected drops are separated from the ink in the nozzle by contact with the print medium or a transfer roller.	<ul style="list-style-type: none"> <li>◆ Very simple print head fabrication can be used</li> <li>◆ The drop selection means does not need to provide the energy required to separate the drop from the nozzle</li> </ul>	<ul style="list-style-type: none"> <li>◆ Requires close proximity between the print head and the print media or transfer roller</li> <li>◆ May require two print heads printing alternate rows of the image</li> <li>◆ Monolithic color print heads are difficult</li> </ul>	<ul style="list-style-type: none"> <li>◆ Silverbrook, EP 0771 658 A2 and related patent applications</li> </ul>
<b>Electrostatic pull on ink</b>	The drops to be printed are selected by some manner (e.g. thermally induced surface tension reduction of pressurized ink). Selected drops are separated from the ink in the nozzle by a strong electric field.	<ul style="list-style-type: none"> <li>◆ Very simple print head fabrication can be used</li> <li>◆ The drop selection means does not need to provide the energy required to separate the drop from the nozzle</li> </ul>	<ul style="list-style-type: none"> <li>◆ Requires very high electrostatic field</li> <li>◆ Electrostatic field for small nozzle sizes is above air breakdown</li> <li>◆ Electrostatic field may attract dust</li> </ul>	<ul style="list-style-type: none"> <li>◆ Silverbrook, EP 0771 658 A2 and related patent applications</li> <li>◆ Tone-Jet</li> </ul>
<b>Magnetic pull on ink</b>	The drops to be printed are selected by some manner (e.g. thermally induced surface tension reduction of pressurized ink). Selected drops are separated from the ink in the nozzle by a strong magnetic field acting on the magnetic ink.	<ul style="list-style-type: none"> <li>◆ Very simple print head fabrication can be used</li> <li>◆ The drop selection means does not need to provide the energy required to separate the drop from the nozzle</li> </ul>	<ul style="list-style-type: none"> <li>◆ Requires magnetic ink</li> <li>◆ Ink colors other than black are difficult</li> <li>◆ Requires very high magnetic fields</li> </ul>	<ul style="list-style-type: none"> <li>◆ Silverbrook, EP 0771 658 A2 and related patent applications</li> </ul>

<b>BASIC OPERATION MODE</b>				
	<b>Description</b>	<b>Advantages</b>	<b>Disadvantages</b>	<b>Examples</b>
<b>Shutter</b>	The actuator moves a shutter to block ink flow to the nozzle. The ink pressure is pulsed at a multiple of the drop ejection frequency.	<ul style="list-style-type: none"> <li>◆ High speed (&gt;50 kHz) operation can be achieved due to reduced refill time</li> <li>◆ Drop timing can be very accurate</li> <li>◆ The actuator energy can be very low</li> </ul>	<ul style="list-style-type: none"> <li>◆ Moving parts are required</li> <li>◆ Requires ink pressure modulator</li> <li>◆ Friction and wear must be considered</li> <li>◆ Stiction is possible</li> </ul>	◆ IJ13, IJ17, IJ21
<b>Shuttered grill</b>	The actuator moves a shutter to block ink flow through a grill to the nozzle. The shutter movement need only be equal to the width of the grill holes.	<ul style="list-style-type: none"> <li>◆ Actuators with small travel can be used</li> <li>◆ Actuators with small force can be used</li> <li>◆ High speed (&gt;50 kHz) operation can be achieved</li> </ul>	<ul style="list-style-type: none"> <li>◆ Moving parts are required</li> <li>◆ Requires ink pressure modulator</li> <li>◆ Friction and wear must be considered</li> <li>◆ Stiction is possible</li> </ul>	◆ IJ08, IJ15, IJ18, IJ19
<b>Pulsed magnetic pull on ink pusher</b>	A pulsed magnetic field attracts an 'ink pusher' at the drop ejection frequency. An actuator controls a catch, which prevents the ink pusher from moving when a drop is not to be ejected.	<ul style="list-style-type: none"> <li>◆ Extremely low energy operation is possible</li> <li>◆ No heat dissipation problems</li> </ul>	<ul style="list-style-type: none"> <li>◆ Requires an external pulsed magnetic field</li> <li>◆ Requires special materials for both the actuator and the ink pusher</li> <li>◆ Complex construction</li> </ul>	◆ IJ10

<b>AUXILIARY MECHANISM (APPLIED TO ALL NOZZLES)</b>				
	<b>Description</b>	<b>Advantages</b>	<b>Disadvantages</b>	<b>Examples</b>
<b>None</b>	The actuator directly fires the ink drop, and there is no external field or other mechanism required.	<ul style="list-style-type: none"> <li>◆ Simplicity of construction</li> <li>◆ Simplicity of operation</li> <li>◆ Small physical size</li> </ul>	<ul style="list-style-type: none"> <li>◆ Drop ejection energy must be supplied by individual nozzle actuator</li> </ul>	<ul style="list-style-type: none"> <li>◆ Most ink jets, including piezoelectric and thermal bubble.</li> <li>◆ IJ01, IJ02, IJ03, IJ04, IJ05, IJ07, IJ09, IJ11, IJ12, IJ14, IJ20, IJ22, IJ23, IJ24, IJ25, IJ26, IJ27, IJ28, IJ29, IJ30, IJ31, IJ32, IJ33, IJ34, IJ35, IJ36, IJ37, IJ38, IJ39, IJ40, IJ41, IJ42, IJ43, IJ44</li> </ul>

AUXILIARY MECHANISM (APPLIED TO ALL NOZZLES)				
	Description	Advantages	Disadvantages	Examples
<b>Oscillating ink pressure (including acoustic stimulation)</b>	The ink pressure oscillates, providing much of the drop ejection energy. The actuator selects which drops are to be fired by selectively blocking or enabling nozzles. The ink pressure oscillation may be achieved by vibrating the print head, or preferably by an actuator in the ink supply.	<ul style="list-style-type: none"> <li>◆ Oscillating ink pressure can provide a refill pulse, allowing higher operating speed</li> <li>◆ The actuators may operate with much lower energy</li> <li>◆ Acoustic lenses can be used to focus the sound on the nozzles</li> </ul>	<ul style="list-style-type: none"> <li>◆ Requires external ink pressure oscillator</li> <li>◆ Ink pressure phase and amplitude must be carefully controlled</li> <li>◆ Acoustic reflections in the ink chamber must be designed for</li> </ul>	<ul style="list-style-type: none"> <li>◆ Silverbrook, EP 0771 658 A2 and related patent applications</li> <li>◆ IJ08, IJ13, IJ15, IJ17, IJ18, IJ19, IJ21</li> </ul>
<b>Media proximity</b>	The print head is placed in close proximity to the print medium. Selected drops protrude from the print head further than unselected drops, and contact the print medium. The drop soaks into the medium fast enough to cause drop separation.	<ul style="list-style-type: none"> <li>◆ Low power</li> <li>◆ High accuracy</li> <li>◆ Simple print head construction</li> </ul>	<ul style="list-style-type: none"> <li>◆ Precision assembly required</li> <li>◆ Paper fibers may cause problems</li> <li>◆ Cannot print on rough substrates</li> </ul>	<ul style="list-style-type: none"> <li>◆ Silverbrook, EP 0771 658 A2 and related patent applications</li> </ul>
<b>Transfer roller</b>	Drops are printed to a transfer roller instead of straight to the print medium. A transfer roller can also be used for proximity drop separation.	<ul style="list-style-type: none"> <li>◆ High accuracy</li> <li>◆ Wide range of print substrates can be used</li> <li>◆ Ink can be dried on the transfer roller</li> </ul>	<ul style="list-style-type: none"> <li>◆ Bulky</li> <li>◆ Expensive</li> <li>◆ Complex construction</li> </ul>	<ul style="list-style-type: none"> <li>◆ Silverbrook, EP 0771 658 A2 and related patent applications</li> <li>◆ Tektronix hot melt piezoelectric ink jet</li> <li>◆ Any of the IJ series</li> </ul>
<b>Electro-static</b>	An electric field is used to accelerate selected drops towards the print medium.	<ul style="list-style-type: none"> <li>◆ Low power</li> <li>◆ Simple print head construction</li> </ul>	<ul style="list-style-type: none"> <li>◆ Field strength required for separation of small drops is near or above air breakdown</li> </ul>	<ul style="list-style-type: none"> <li>◆ Silverbrook, EP 0771 658 A2 and related patent applications</li> <li>◆ Tone-Jet</li> </ul>
<b>Direct magnetic field</b>	A magnetic field is used to accelerate selected drops of magnetic ink towards the print medium.	<ul style="list-style-type: none"> <li>◆ Low power</li> <li>◆ Simple print head construction</li> </ul>	<ul style="list-style-type: none"> <li>◆ Requires magnetic ink</li> <li>◆ Requires strong magnetic field</li> </ul>	<ul style="list-style-type: none"> <li>◆ Silverbrook, EP 0771 658 A2 and related patent applications</li> </ul>
<b>Cross magnetic field</b>	The print head is placed in a constant magnetic field. The Lorenz force in a current carrying wire is used to move the actuator.	<ul style="list-style-type: none"> <li>◆ Does not require magnetic materials to be integrated in the print head manufacturing process</li> </ul>	<ul style="list-style-type: none"> <li>◆ Requires external magnet</li> <li>◆ Current densities may be high, resulting in electromigration problems</li> </ul>	<ul style="list-style-type: none"> <li>◆ IJ06, IJ16</li> </ul>

<b>AUXILIARY MECHANISM (APPLIED TO ALL NOZZLES)</b>				
	<b>Description</b>	<b>Advantages</b>	<b>Disadvantages</b>	<b>Examples</b>
<b>Pulsed magnetic field</b>	A pulsed magnetic field is used to cyclically attract a paddle, which pushes on the ink. A small actuator moves a catch, which selectively prevents the paddle from moving.	<ul style="list-style-type: none"><li>◆ Very low power operation is possible</li><li>◆ Small print head size</li></ul>	<ul style="list-style-type: none"><li>◆ Complex print head construction</li><li>◆ Magnetic materials required in print head</li></ul>	<ul style="list-style-type: none"><li>◆ IJ10</li></ul>

ACTUATOR AMPLIFICATION OR MODIFICATION METHOD				
	Description	Advantages	Disadvantages	Examples
<b>None</b>	No actuator mechanical amplification is used. The actuator directly drives the drop ejection process.	<ul style="list-style-type: none"> <li>◆ Operational simplicity</li> </ul>	<ul style="list-style-type: none"> <li>◆ Many actuator mechanisms have insufficient travel, or insufficient force, to efficiently drive the drop ejection process</li> </ul>	<ul style="list-style-type: none"> <li>◆ Thermal Bubble Ink jet</li> <li>◆ IJ01, IJ02, IJ06, IJ07, IJ16, IJ25, IJ26</li> </ul>
<b>Differential expansion bend actuator</b>	An actuator material expands more on one side than on the other. The expansion may be thermal, piezoelectric, magnetostrictive, or other mechanism. The bend actuator converts a high force low travel actuator mechanism to high travel, lower force mechanism.	<ul style="list-style-type: none"> <li>◆ Provides greater travel in a reduced print head area</li> </ul>	<ul style="list-style-type: none"> <li>◆ High stresses are involved</li> <li>◆ Care must be taken that the materials do not delaminate</li> <li>◆ Residual bend resulting from high temperature or high stress during formation</li> </ul>	<ul style="list-style-type: none"> <li>◆ Piezoelectric</li> <li>◆ IJ03, IJ09, IJ17, IJ18, IJ19, IJ20, IJ21, IJ22, IJ23, IJ24, IJ27, IJ29, IJ30, IJ31, IJ32, IJ33, IJ34, IJ35, IJ36, IJ37, IJ38, IJ39, IJ42, IJ43, IJ44</li> </ul>
<b>Transient bend actuator</b>	A trilayer bend actuator where the two outside layers are identical. This cancels bend due to ambient temperature and residual stress. The actuator only responds to transient heating of one side or the other.	<ul style="list-style-type: none"> <li>◆ Very good temperature stability</li> <li>◆ High speed, as a new drop can be fired before heat dissipates</li> <li>◆ Cancels residual stress of formation</li> </ul>	<ul style="list-style-type: none"> <li>◆ High stresses are involved</li> <li>◆ Care must be taken that the materials do not delaminate</li> </ul>	<ul style="list-style-type: none"> <li>◆ IJ40, IJ41</li> </ul>
<b>Reverse spring</b>	The actuator loads a spring. When the actuator is turned off, the spring releases. This can reverse the force/distance curve of the actuator to make it compatible with the force/time requirements of the drop ejection.	<ul style="list-style-type: none"> <li>◆ Better coupling to the ink</li> </ul>	<ul style="list-style-type: none"> <li>◆ Fabrication complexity</li> <li>◆ High stress in the spring</li> </ul>	<ul style="list-style-type: none"> <li>◆ IJ05, IJ11</li> </ul>
<b>Actuator stack</b>	A series of thin actuators are stacked. This can be appropriate where actuators require high electric field strength, such as electrostatic and piezoelectric actuators.	<ul style="list-style-type: none"> <li>◆ Increased travel</li> <li>◆ Reduced drive voltage</li> </ul>	<ul style="list-style-type: none"> <li>◆ Increased fabrication complexity</li> <li>◆ Increased possibility of short circuits due to pinholes</li> </ul>	<ul style="list-style-type: none"> <li>◆ Some piezoelectric ink jets</li> <li>◆ IJ04</li> </ul>

ACTUATOR AMPLIFICATION OR MODIFICATION METHOD				
	Description	Advantages	Disadvantages	Examples
<b>Multiple actuators</b>	Multiple smaller actuators are used simultaneously to move the ink. Each actuator need provide only a portion of the force required.	<ul style="list-style-type: none"> <li>◆ Increases the force available from an actuator</li> <li>◆ Multiple actuators can be positioned to control ink flow accurately</li> </ul>	<ul style="list-style-type: none"> <li>◆ Actuator forces may not add linearly, reducing efficiency</li> </ul>	<ul style="list-style-type: none"> <li>◆ IJ12, IJ13, IJ18, IJ20, IJ22, IJ28, IJ42, IJ43</li> </ul>
<b>Linear Spring</b>	A linear spring is used to transform a motion with small travel and high force into a longer travel, lower force motion.	<ul style="list-style-type: none"> <li>◆ Matches low travel actuator with higher travel requirements</li> <li>◆ Non-contact method of motion transformation</li> </ul>	<ul style="list-style-type: none"> <li>◆ Requires print head area for the spring</li> </ul>	<ul style="list-style-type: none"> <li>◆ IJ15</li> </ul>
<b>Coiled actuator</b>	A bend actuator is coiled to provide greater travel in a reduced chip area.	<ul style="list-style-type: none"> <li>◆ Increases travel</li> <li>◆ Reduces chip area</li> <li>◆ Planar implementations are relatively easy to fabricate.</li> </ul>	<ul style="list-style-type: none"> <li>◆ Generally restricted to planar implementations due to extreme fabrication difficulty in other orientations.</li> </ul>	<ul style="list-style-type: none"> <li>◆ IJ17, IJ21, IJ34, IJ35</li> </ul>
<b>Flexure bend actuator</b>	A bend actuator has a small region near the fixture point, which flexes much more readily than the remainder of the actuator. The actuator flexing is effectively converted from an even coiling to an angular bend, resulting in greater travel of the actuator tip.	<ul style="list-style-type: none"> <li>◆ Simple means of increasing travel of a bend actuator</li> </ul>	<ul style="list-style-type: none"> <li>◆ Care must be taken not to exceed the elastic limit in the flexure area</li> <li>◆ Stress distribution is very uneven</li> <li>◆ Difficult to accurately model with finite element analysis</li> </ul>	<ul style="list-style-type: none"> <li>◆ IJ10, IJ19, IJ33</li> </ul>
<b>Catch</b>	The actuator controls a small catch. The catch either enables or disables movement of an ink pusher that is controlled in a bulk manner.	<ul style="list-style-type: none"> <li>◆ Very low actuator energy</li> <li>◆ Very small actuator size</li> </ul>	<ul style="list-style-type: none"> <li>◆ Complex construction</li> <li>◆ Requires external force</li> <li>◆ Unsuitable for pigmented inks</li> </ul>	<ul style="list-style-type: none"> <li>◆ IJ10</li> </ul>
<b>Gears</b>	Gears can be used to increase travel at the expense of duration. Circular gears, rack and pinion, ratchets, and other gearing methods can be used.	<ul style="list-style-type: none"> <li>◆ Low force, low travel actuators can be used</li> <li>◆ Can be fabricated using standard surface MEMS processes</li> </ul>	<ul style="list-style-type: none"> <li>◆ Moving parts are required</li> <li>◆ Several actuator cycles are required</li> <li>◆ More complex drive electronics</li> <li>◆ Complex construction</li> <li>◆ Friction, friction, and wear are possible</li> </ul>	<ul style="list-style-type: none"> <li>◆ IJ13</li> </ul>

ACTUATOR AMPLIFICATION OR MODIFICATION METHOD				
	Description	Advantages	Disadvantages	Examples
<b>Buckle plate</b>	A buckle plate can be used to change a slow actuator into a fast motion. It can also convert a high force, low travel actuator into a high travel, medium force motion.	<ul style="list-style-type: none"> <li>◆ Very fast movement achievable</li> </ul>	<ul style="list-style-type: none"> <li>◆ Must stay within elastic limits of the materials for long device life</li> <li>◆ High stresses involved</li> <li>◆ Generally high power requirement</li> </ul>	<ul style="list-style-type: none"> <li>◆ S. Hirata et al, "An Ink-jet Head Using Diaphragm Microactuator", Proc. IEEE MEMS, Feb. 1996, pp 418-423.</li> <li>◆ IJ18, IJ27</li> </ul>
<b>Tapered magnetic pole</b>	A tapered magnetic pole can increase travel at the expense of force.	<ul style="list-style-type: none"> <li>◆ Linearizes the magnetic force/distance curve</li> </ul>	<ul style="list-style-type: none"> <li>◆ Complex construction</li> </ul>	<ul style="list-style-type: none"> <li>◆ IJ14</li> </ul>
<b>Lever</b>	A lever and fulcrum is used to transform a motion with small travel and high force into a motion with longer travel and lower force. The lever can also reverse the direction of travel.	<ul style="list-style-type: none"> <li>◆ Matches low travel actuator with higher travel requirements</li> <li>◆ Fulcrum area has no linear movement, and can be used for a fluid seal</li> </ul>	<ul style="list-style-type: none"> <li>◆ High stress around the fulcrum</li> </ul>	<ul style="list-style-type: none"> <li>◆ IJ32, IJ36, IJ37</li> </ul>
<b>Rotary impeller</b>	The actuator is connected to a rotary impeller. A small angular deflection of the actuator results in a rotation of the impeller vanes, which push the ink against stationary vanes and out of the nozzle.	<ul style="list-style-type: none"> <li>◆ High mechanical advantage</li> <li>◆ The ratio of force to travel of the actuator can be matched to the nozzle requirements by varying the number of impeller vanes</li> </ul>	<ul style="list-style-type: none"> <li>◆ Complex construction</li> <li>◆ Unsuitable for pigmented inks</li> </ul>	<ul style="list-style-type: none"> <li>◆ IJ28</li> </ul>
<b>Acoustic lens</b>	A refractive or diffractive (e.g. zone plate) acoustic lens is used to concentrate sound waves.	<ul style="list-style-type: none"> <li>◆ No moving parts</li> </ul>	<ul style="list-style-type: none"> <li>◆ Large area required</li> <li>◆ Only relevant for acoustic ink jets</li> </ul>	<ul style="list-style-type: none"> <li>◆ 1993 Hadimioglu et al, EUP 550,192</li> <li>◆ 1993 Elrod et al, EUP 572,220</li> </ul>
<b>Sharp conductive point</b>	A sharp point is used to concentrate an electrostatic field.	<ul style="list-style-type: none"> <li>◆ Simple construction</li> </ul>	<ul style="list-style-type: none"> <li>◆ Difficult to fabricate using standard VLSI processes for a surface ejecting ink-jet</li> <li>◆ Only relevant for electrostatic ink jets</li> </ul>	<ul style="list-style-type: none"> <li>◆ Tone-jet</li> </ul>



ACTUATOR MOTION				
	Description	Advantages	Disadvantages	Examples
<b>Volume expansion</b>	The volume of the actuator changes, pushing the ink in all directions.	<ul style="list-style-type: none"> <li>◆ Simple construction in the case of thermal ink jet</li> </ul>	<ul style="list-style-type: none"> <li>◆ High energy is typically required to achieve volume expansion. This leads to thermal stress, cavitation, and kogation in thermal ink jet implementations</li> </ul>	<ul style="list-style-type: none"> <li>◆ Hewlett-Packard Thermal Ink jet</li> <li>◆ Canon Bubblejet</li> </ul>
<b>Linear, normal to chip surface</b>	The actuator moves in a direction normal to the print head surface. The nozzle is typically in the line of movement.	<ul style="list-style-type: none"> <li>◆ Efficient coupling to ink drops ejected normal to the surface</li> </ul>	<ul style="list-style-type: none"> <li>◆ High fabrication complexity may be required to achieve perpendicular motion</li> </ul>	<ul style="list-style-type: none"> <li>◆ IJ01, IJ02, IJ04, IJ07, IJ11, IJ14</li> </ul>
<b>Parallel to chip surface</b>	The actuator moves parallel to the print head surface. Drop ejection may still be normal to the surface.	<ul style="list-style-type: none"> <li>◆ Suitable for planar fabrication</li> </ul>	<ul style="list-style-type: none"> <li>◆ Fabrication complexity</li> <li>◆ Friction</li> <li>◆ Stiction</li> </ul>	<ul style="list-style-type: none"> <li>◆ IJ12, IJ13, IJ15, IJ33, , IJ34, IJ35, IJ36</li> </ul>
<b>Membrane push</b>	An actuator with a high force but small area is used to push a stiff membrane that is in contact with the ink.	<ul style="list-style-type: none"> <li>◆ The effective area of the actuator becomes the membrane area</li> </ul>	<ul style="list-style-type: none"> <li>◆ Fabrication complexity</li> <li>◆ Actuator size</li> <li>◆ Difficulty of integration in a VLSI process</li> </ul>	<ul style="list-style-type: none"> <li>◆ 1982 Howkins USP 4,459,601</li> </ul>
<b>Rotary</b>	The actuator causes the rotation of some element, such a grill or impeller	<ul style="list-style-type: none"> <li>◆ Rotary levers may be used to increase travel</li> <li>◆ Small chip area requirements</li> </ul>	<ul style="list-style-type: none"> <li>◆ Device complexity</li> <li>◆ May have friction at a pivot point</li> </ul>	<ul style="list-style-type: none"> <li>◆ IJ05, IJ08, IJ13, IJ28</li> </ul>
<b>Bend</b>	The actuator bends when energized. This may be due to differential thermal expansion, piezoelectric expansion, magnetostriction, or other form of relative dimensional change.	<ul style="list-style-type: none"> <li>◆ A very small change in dimensions can be converted to a large motion.</li> </ul>	<ul style="list-style-type: none"> <li>◆ Requires the actuator to be made from at least two distinct layers, or to have a thermal difference across the actuator</li> </ul>	<ul style="list-style-type: none"> <li>◆ 1970 Kyser et al USP 3,946,398</li> <li>◆ 1973 Stemme USP 3,747,120</li> <li>◆ IJ03, IJ09, IJ10, IJ19, IJ23, IJ24, IJ25, IJ29, IJ30, IJ31, IJ33, IJ34, IJ35</li> </ul>
<b>Swivel</b>	The actuator swivels around a central pivot. This motion is suitable where there are opposite forces applied to opposite sides of the paddle, e.g. Lorenz force.	<ul style="list-style-type: none"> <li>◆ Allows operation where the net linear force on the paddle is zero</li> <li>◆ Small chip area requirements</li> </ul>	<ul style="list-style-type: none"> <li>◆ Inefficient coupling to the ink motion</li> </ul>	<ul style="list-style-type: none"> <li>◆ IJ06</li> </ul>
<b>Straighten</b>	The actuator is normally bent, and straightens when energized.	<ul style="list-style-type: none"> <li>◆ Can be used with shape memory alloys where the austenitic phase is planar</li> </ul>	<ul style="list-style-type: none"> <li>◆ Requires careful balance of stresses to ensure that the quiescent bend is accurate</li> </ul>	<ul style="list-style-type: none"> <li>◆ IJ26, IJ32</li> </ul>

ACTUATOR MOTION				
	Description	Advantages	Disadvantages	Examples
<b>Double bend</b>	The actuator bends in one direction when one element is energized, and bends the other way when another element is energized.	<ul style="list-style-type: none"> <li>◆ One actuator can be used to power two nozzles.</li> <li>◆ Reduced chip size.</li> <li>◆ Not sensitive to ambient temperature</li> </ul>	<ul style="list-style-type: none"> <li>◆ Difficult to make the drops ejected by both bend directions identical.</li> <li>◆ A small efficiency loss compared to equivalent single bend actuators.</li> </ul>	◆ IJ36, IJ37, IJ38
<b>Shear</b>	Energizing the actuator causes a shear motion in the actuator material.	<ul style="list-style-type: none"> <li>◆ Can increase the effective travel of piezoelectric actuators</li> </ul>	<ul style="list-style-type: none"> <li>◆ Not readily applicable to other actuator mechanisms</li> </ul>	◆ 1985 Fishbeck USP 4,584,590
<b>Radial constriction</b>	The actuator squeezes an ink reservoir, forcing ink from a constricted nozzle.	<ul style="list-style-type: none"> <li>◆ Relatively easy to fabricate single nozzles from glass tubing as macroscopic structures</li> </ul>	<ul style="list-style-type: none"> <li>◆ High force required</li> <li>◆ Inefficient</li> <li>◆ Difficult to integrate with VLSI processes</li> </ul>	◆ 1970 Zoltan USP 3,683,212
<b>Coil / uncoil</b>	A coiled actuator uncoils or coils more tightly. The motion of the free end of the actuator ejects the ink.	<ul style="list-style-type: none"> <li>◆ Easy to fabricate as a planar VLSI process</li> <li>◆ Small area required, therefore low cost</li> </ul>	<ul style="list-style-type: none"> <li>◆ Difficult to fabricate for non-planar devices</li> <li>◆ Poor out-of-plane stiffness</li> </ul>	◆ IJ17, IJ21, IJ34, IJ35
<b>Bow</b>	The actuator bows (or buckles) in the middle when energized.	<ul style="list-style-type: none"> <li>◆ Can increase the speed of travel</li> <li>◆ Mechanically rigid</li> </ul>	<ul style="list-style-type: none"> <li>◆ Maximum travel is constrained</li> <li>◆ High force required</li> </ul>	◆ IJ16, IJ18, IJ27
<b>Push-Pull</b>	Two actuators control a shutter. One actuator pulls the shutter, and the other pushes it.	<ul style="list-style-type: none"> <li>◆ The structure is pinned at both ends, so has a high out-of-plane rigidity</li> </ul>	<ul style="list-style-type: none"> <li>◆ Not readily suitable for ink jets which directly push the ink</li> </ul>	◆ IJ18
<b>Curl inwards</b>	A set of actuators curl inwards to reduce the volume of ink that they enclose.	<ul style="list-style-type: none"> <li>◆ Good fluid flow to the region behind the actuator increases efficiency</li> </ul>	<ul style="list-style-type: none"> <li>◆ Design complexity</li> </ul>	◆ IJ20, IJ42
<b>Curl outwards</b>	A set of actuators curl outwards, pressurizing ink in a chamber surrounding the actuators, and expelling ink from a nozzle in the chamber.	<ul style="list-style-type: none"> <li>◆ Relatively simple construction</li> </ul>	<ul style="list-style-type: none"> <li>◆ Relatively large chip area</li> </ul>	◆ IJ43
<b>Iris</b>	Multiple vanes enclose a volume of ink. These simultaneously rotate, reducing the volume between the vanes.	<ul style="list-style-type: none"> <li>◆ High efficiency</li> <li>◆ Small chip area</li> </ul>	<ul style="list-style-type: none"> <li>◆ High fabrication complexity</li> <li>◆ Not suitable for pigmented inks</li> </ul>	◆ IJ22

<b>ACTUATOR MOTION</b>				
	<b>Description</b>	<b>Advantages</b>	<b>Disadvantages</b>	<b>Examples</b>
<b>Acoustic vibration</b>	The actuator vibrates at a high frequency.	<ul style="list-style-type: none"> <li>◆ The actuator can be physically distant from the ink</li> </ul>	<ul style="list-style-type: none"> <li>◆ Large area required for efficient operation at useful frequencies</li> <li>◆ Acoustic coupling and crosstalk</li> <li>◆ Complex drive circuitry</li> <li>◆ Poor control of drop volume and position</li> </ul>	<ul style="list-style-type: none"> <li>◆ 1993 Hadimioglu et al, EUP 550,192</li> <li>◆ 1993 Elrod et al, EUP 572,220</li> </ul>
<b>None</b>	In various ink jet designs the actuator does not move.	<ul style="list-style-type: none"> <li>◆ No moving parts</li> </ul>	<ul style="list-style-type: none"> <li>◆ Various other tradeoffs are required to eliminate moving parts</li> </ul>	<ul style="list-style-type: none"> <li>◆ Silverbrook, EP 0771 658 A2 and related patent applications</li> <li>◆ Tone-jet</li> </ul>

<b>NOZZLE REFILL METHOD</b>				
	<b>Description</b>	<b>Advantages</b>	<b>Disadvantages</b>	<b>Examples</b>
<b>Surface tension</b>	This is the normal way that ink jets are refilled. After the actuator is energized, it typically returns rapidly to its normal position. This rapid return sucks in air through the nozzle opening. The ink surface tension at the nozzle then exerts a small force restoring the meniscus to a minimum area. This force refills the nozzle.	<ul style="list-style-type: none"> <li>◆ Fabrication simplicity</li> <li>◆ Operational simplicity</li> </ul>	<ul style="list-style-type: none"> <li>◆ Low speed</li> <li>◆ Surface tension force relatively small compared to actuator force</li> <li>◆ Long refill time usually dominates the total repetition rate</li> </ul>	<ul style="list-style-type: none"> <li>◆ Thermal ink jet</li> <li>◆ Piezoelectric ink jet</li> <li>◆ IJ01-IJ07, IJ10-IJ14, IJ16, IJ20, IJ22-IJ45</li> </ul>
<b>Shuttered oscillating ink pressure</b>	Ink to the nozzle chamber is provided at a pressure that oscillates at twice the drop ejection frequency. When a drop is to be ejected, the shutter is opened for 3 half cycles: drop ejection, actuator return, and refill. The shutter is then closed to prevent the nozzle chamber emptying during the next negative pressure cycle.	<ul style="list-style-type: none"> <li>◆ High speed</li> <li>◆ Low actuator energy, as the actuator need only open or close the shutter, instead of ejecting the ink drop</li> </ul>	<ul style="list-style-type: none"> <li>◆ Requires common ink pressure oscillator</li> <li>◆ May not be suitable for pigmented inks</li> </ul>	<ul style="list-style-type: none"> <li>◆ IJ08, IJ13, IJ15, IJ17, IJ18, IJ19, IJ21</li> </ul>
<b>Refill actuator</b>	After the main actuator has ejected a drop a second (refill) actuator is energized. The refill actuator pushes ink into the nozzle chamber. The refill actuator returns slowly, to prevent its return from emptying the chamber again.	<ul style="list-style-type: none"> <li>◆ High speed, as the nozzle is actively refilled</li> </ul>	<ul style="list-style-type: none"> <li>◆ Requires two independent actuators per nozzle</li> </ul>	<ul style="list-style-type: none"> <li>◆ IJ09</li> </ul>
<b>Positive ink pressure</b>	The ink is held a slight positive pressure. After the ink drop is ejected, the nozzle chamber fills quickly as surface tension and ink pressure both operate to refill the nozzle.	<ul style="list-style-type: none"> <li>◆ High refill rate, therefore a high drop repetition rate is possible</li> </ul>	<ul style="list-style-type: none"> <li>◆ Surface spill must be prevented</li> <li>◆ Highly hydrophobic print head surfaces are required</li> </ul>	<ul style="list-style-type: none"> <li>◆ Silverbrook, EP 0771 658 A2 and related patent applications</li> <li>◆ Alternative for:, IJ01-IJ07, IJ10-IJ14, IJ16, IJ20, IJ22-IJ45</li> </ul>

<b>METHOD OF RESTRICTING BACK-FLOW THROUGH INLET</b>				
	<b>Description</b>	<b>Advantages</b>	<b>Disadvantages</b>	<b>Examples</b>
<b>Long inlet channel</b>	The ink inlet channel to the nozzle chamber is made long and relatively narrow, relying on viscous drag to reduce inlet back-flow.	<ul style="list-style-type: none"> <li>◆ Design simplicity</li> <li>◆ Operational simplicity</li> <li>◆ Reduces crosstalk</li> </ul>	<ul style="list-style-type: none"> <li>◆ Restricts refill rate</li> <li>◆ May result in a relatively large chip area</li> <li>◆ Only partially effective</li> </ul>	<ul style="list-style-type: none"> <li>◆ Thermal ink jet</li> <li>◆ Piezoelectric ink jet</li> <li>◆ IJ42, IJ43</li> </ul>
<b>Positive ink pressure</b>	The ink is under a positive pressure, so that in the quiescent state some of the ink drop already protrudes from the nozzle. This reduces the pressure in the nozzle chamber which is required to eject a certain volume of ink. The reduction in chamber pressure results in a reduction in ink pushed out through the inlet.	<ul style="list-style-type: none"> <li>◆ Drop selection and separation forces can be reduced</li> <li>◆ Fast refill time</li> </ul>	<ul style="list-style-type: none"> <li>◆ Requires a method (such as a nozzle rim or effective hydrophobizing, or both) to prevent flooding of the ejection surface of the print head.</li> </ul>	<ul style="list-style-type: none"> <li>◆ Silverbrook, EP 0771 658 A2 and related patent applications</li> <li>◆ Possible operation of the following: IJ01-IJ07, IJ09- IJ12, IJ14, IJ16, IJ20, IJ22, , IJ23-IJ34, IJ36- IJ41, IJ44</li> </ul>
<b>Baffle</b>	One or more baffles are placed in the inlet ink flow. When the actuator is energized, the rapid ink movement creates eddies which restrict the flow through the inlet. The slower refill process is unrestricted, and does not result in eddies.	<ul style="list-style-type: none"> <li>◆ The refill rate is not as restricted as the long inlet method.</li> <li>◆ Reduces crosstalk</li> </ul>	<ul style="list-style-type: none"> <li>◆ Design complexity</li> <li>◆ May increase fabrication complexity (e.g. Tektronix hot melt Piezoelectric print heads).</li> </ul>	<ul style="list-style-type: none"> <li>◆ HP Thermal Ink Jet</li> <li>◆ Tektronix piezoelectric ink jet</li> </ul>
<b>Flexible flap restricts inlet</b>	In this method recently disclosed by Canon, the expanding actuator (bubble) pushes on a flexible flap that restricts the inlet.	<ul style="list-style-type: none"> <li>◆ Significantly reduces back-flow for edge-shooter thermal ink jet devices</li> </ul>	<ul style="list-style-type: none"> <li>◆ Not applicable to most ink jet configurations</li> <li>◆ Increased fabrication complexity</li> <li>◆ Inelastic deformation of polymer flap results in creep over extended use</li> </ul>	<ul style="list-style-type: none"> <li>◆ Canon</li> </ul>

<b>METHOD OF RESTRICTING BACK-FLOW THROUGH INLET</b>				
	<b>Description</b>	<b>Advantages</b>	<b>Disadvantages</b>	<b>Examples</b>
<b>Inlet filter</b>	A filter is located between the ink inlet and the nozzle chamber. The filter has a multitude of small holes or slots, restricting ink flow. The filter also removes particles which may block the nozzle.	<ul style="list-style-type: none"> <li>◆ Additional advantage of ink filtration</li> <li>◆ Ink filter may be fabricated with no additional process steps</li> </ul>	<ul style="list-style-type: none"> <li>◆ Restricts refill rate</li> <li>◆ May result in complex construction</li> </ul>	<ul style="list-style-type: none"> <li>◆ IJ04, IJ12, IJ24, IJ27, IJ29, IJ30</li> </ul>
<b>Small inlet compared to nozzle</b>	The ink inlet channel to the nozzle chamber has a substantially smaller cross section than that of the nozzle, resulting in easier ink egress out of the nozzle than out of the inlet.	<ul style="list-style-type: none"> <li>◆ Design simplicity</li> </ul>	<ul style="list-style-type: none"> <li>◆ Restricts refill rate</li> <li>◆ May result in a relatively large chip area</li> <li>◆ Only partially effective</li> </ul>	<ul style="list-style-type: none"> <li>◆ IJ02, IJ37, IJ44</li> </ul>
<b>Inlet shutter</b>	A secondary actuator controls the position of a shutter, closing off the ink inlet when the main actuator is energized.	<ul style="list-style-type: none"> <li>◆ Increases speed of the ink-jet print head operation</li> </ul>	<ul style="list-style-type: none"> <li>◆ Requires separate refill actuator and drive circuit</li> </ul>	<ul style="list-style-type: none"> <li>◆ IJ09</li> </ul>
<b>The inlet is located behind the ink-pushing surface</b>	The method avoids the problem of inlet back-flow by arranging the ink-pushing surface of the actuator between the inlet and the nozzle.	<ul style="list-style-type: none"> <li>◆ Back-flow problem is eliminated</li> </ul>	<ul style="list-style-type: none"> <li>◆ Requires careful design to minimize the negative pressure behind the paddle</li> </ul>	<ul style="list-style-type: none"> <li>◆ IJ01, IJ03, IJ05, IJ06, IJ07, IJ10, IJ11, IJ14, IJ16, IJ22, IJ23, IJ25, IJ28, IJ31, IJ32, IJ33, IJ34, IJ35, IJ36, IJ39, IJ40, IJ41</li> </ul>
<b>Part of the actuator moves to shut off the inlet</b>	The actuator and a wall of the ink chamber are arranged so that the motion of the actuator closes off the inlet.	<ul style="list-style-type: none"> <li>◆ Significant reductions in back-flow can be achieved</li> <li>◆ Compact designs possible</li> </ul>	<ul style="list-style-type: none"> <li>◆ Small increase in fabrication complexity</li> </ul>	<ul style="list-style-type: none"> <li>◆ IJ07, IJ20, IJ26, IJ38</li> </ul>
<b>Nozzle actuator does not result in ink back-flow</b>	In some configurations of ink jet, there is no expansion or movement of an actuator which may cause ink back-flow through the inlet.	<ul style="list-style-type: none"> <li>◆ Ink back-flow problem is eliminated</li> </ul>	<ul style="list-style-type: none"> <li>◆ None related to ink back-flow on actuation</li> </ul>	<ul style="list-style-type: none"> <li>◆ Silverbrook, EP 0771 658 A2 and related patent applications</li> <li>◆ Valve-jet</li> <li>◆ Tone-jet</li> </ul>

<b>NOZZLE CLEARING METHOD</b>				
	<b>Description</b>	<b>Advantages</b>	<b>Disadvantages</b>	<b>Examples</b>
<b>Normal nozzle firing</b>	All of the nozzles are fired periodically, before the ink has a chance to dry. When not in use the nozzles are sealed (capped) against air. The nozzle firing is usually performed during a special clearing cycle, after first moving the print head to a cleaning station.	<ul style="list-style-type: none"> <li>◆ No added complexity on the print head</li> </ul>	<ul style="list-style-type: none"> <li>◆ May not be sufficient to displace dried ink</li> </ul>	<ul style="list-style-type: none"> <li>◆ Most ink jet systems</li> <li>◆ IJ01, IJ02, IJ03, IJ04, IJ05, IJ06, IJ07, IJ09, IJ10, IJ11, IJ12, IJ14, IJ16, IJ20, IJ22, IJ23, IJ24, IJ25, IJ26, IJ27, IJ28, IJ29, IJ30, IJ31, IJ32, IJ33, IJ34, IJ36, IJ37, IJ38, IJ39, IJ40,, IJ41, IJ42, IJ43, IJ44,, IJ45</li> </ul>
<b>Extra power to ink heater</b>	In systems which heat the ink, but do not boil it under normal situations, nozzle clearing can be achieved by over-powering the heater and boiling ink at the nozzle.	<ul style="list-style-type: none"> <li>◆ Can be highly effective if the heater is adjacent to the nozzle</li> </ul>	<ul style="list-style-type: none"> <li>◆ Requires higher drive voltage for clearing</li> <li>◆ May require larger drive transistors</li> </ul>	<ul style="list-style-type: none"> <li>◆ Silverbrook, EP 0771 658 A2 and related patent applications</li> </ul>
<b>Rapid succession of actuator pulses</b>	The actuator is fired in rapid succession. In some configurations, this may cause heat build-up at the nozzle which boils the ink, clearing the nozzle. In other situations, it may cause sufficient vibrations to dislodge clogged nozzles.	<ul style="list-style-type: none"> <li>◆ Does not require extra drive circuits on the print head</li> <li>◆ Can be readily controlled and initiated by digital logic</li> </ul>	<ul style="list-style-type: none"> <li>◆ Effectiveness depends substantially upon the configuration of the ink jet nozzle</li> </ul>	<ul style="list-style-type: none"> <li>◆ May be used with: IJ01, IJ02, IJ03, IJ04, IJ05, IJ06, IJ07, IJ09, IJ10, IJ11, IJ14, IJ16, IJ20, IJ22, IJ23, IJ24, IJ25, IJ27, IJ28, IJ29, IJ30, IJ31, IJ32, IJ33, IJ34, IJ36, IJ37, IJ38, IJ39, IJ40, IJ41, IJ42, IJ43, IJ44, IJ45</li> </ul>
<b>Extra power to ink pushing actuator</b>	Where an actuator is not normally driven to the limit of its motion, nozzle clearing may be assisted by providing an enhanced drive signal to the actuator.	<ul style="list-style-type: none"> <li>◆ A simple solution where applicable</li> </ul>	<ul style="list-style-type: none"> <li>◆ Not suitable where there is a hard limit to actuator movement</li> </ul>	<ul style="list-style-type: none"> <li>◆ May be used with: IJ03, IJ09, IJ16, IJ20, IJ23, IJ24, IJ25, IJ27, IJ29, IJ30, IJ31, IJ32, IJ39, IJ40, IJ41, IJ42, IJ43, IJ44, IJ45</li> </ul>

<b>NOZZLE CLEARING METHOD</b>				
	<b>Description</b>	<b>Advantages</b>	<b>Disadvantages</b>	<b>Examples</b>
<b>Acoustic resonance</b>	An ultrasonic wave is applied to the ink chamber. This wave is of an appropriate amplitude and frequency to cause sufficient force at the nozzle to clear blockages. This is easiest to achieve if the ultrasonic wave is at a resonant frequency of the ink cavity.	<ul style="list-style-type: none"> <li>◆ A high nozzle clearing capability can be achieved</li> <li>◆ May be implemented at very low cost in systems which already include acoustic actuators</li> </ul>	<ul style="list-style-type: none"> <li>◆ High implementation cost if system does not already include an acoustic actuator</li> </ul>	<ul style="list-style-type: none"> <li>◆ IJ08, IJ13, IJ15, IJ17, IJ18, IJ19, IJ21</li> </ul>
<b>Nozzle clearing plate</b>	A microfabricated plate is pushed against the nozzles. The plate has a post for every nozzle. A post moves through each nozzle, displacing dried ink.	<ul style="list-style-type: none"> <li>◆ Can clear severely clogged nozzles</li> </ul>	<ul style="list-style-type: none"> <li>◆ Accurate mechanical alignment is required</li> <li>◆ Moving parts are required</li> <li>◆ There is risk of damage to the nozzles</li> <li>◆ Accurate fabrication is required</li> </ul>	<ul style="list-style-type: none"> <li>◆ Silverbrook, EP 0771 658 A2 and related patent applications</li> </ul>
<b>Ink pressure pulse</b>	The pressure of the ink is temporarily increased so that ink streams from all of the nozzles. This may be used in conjunction with actuator energizing.	<ul style="list-style-type: none"> <li>◆ May be effective where other methods cannot be used</li> </ul>	<ul style="list-style-type: none"> <li>◆ Requires pressure pump or other pressure actuator</li> <li>◆ Expensive</li> <li>◆ Wasteful of ink</li> </ul>	<ul style="list-style-type: none"> <li>◆ May be used with all IJ series ink jets</li> </ul>
<b>Print head wiper</b>	A flexible 'blade' is wiped across the print head surface. The blade is usually fabricated from a flexible polymer, e.g. rubber or synthetic elastomer.	<ul style="list-style-type: none"> <li>◆ Effective for planar print head surfaces</li> <li>◆ Low cost</li> </ul>	<ul style="list-style-type: none"> <li>◆ Difficult to use if print head surface is non-planar or very fragile</li> <li>◆ Requires mechanical parts</li> <li>◆ Blade can wear out in high volume print systems</li> </ul>	<ul style="list-style-type: none"> <li>◆ Many ink jet systems</li> </ul>
<b>Separate ink boiling heater</b>	A separate heater is provided at the nozzle although the normal drop ejection mechanism does not require it. The heaters do not require individual drive circuits, as many nozzles can be cleared simultaneously, and no imaging is required.	<ul style="list-style-type: none"> <li>◆ Can be effective where other nozzle clearing methods cannot be used</li> <li>◆ Can be implemented at no additional cost in some ink jet configurations</li> </ul>	<ul style="list-style-type: none"> <li>◆ Fabrication complexity</li> </ul>	<ul style="list-style-type: none"> <li>◆ Can be used with many IJ series ink jets</li> </ul>



NOZZLE CLEARING METHOD				
	Description	Advantages	Disadvantages	Examples
NOZZLE PLATE CONSTRUCTION				
	Description	Advantages	Disadvantages	Examples
<b>Electro-formed nickel</b>	A nozzle plate is separately fabricated from electroformed nickel, and bonded to the print head chip.	<ul style="list-style-type: none"> <li>◆ Fabrication simplicity</li> </ul>	<ul style="list-style-type: none"> <li>◆ High temperatures and pressures are required to bond nozzle plate</li> <li>◆ Minimum thickness constraints</li> <li>◆ Differential thermal expansion</li> </ul>	<ul style="list-style-type: none"> <li>◆ Hewlett Packard Thermal Ink jet</li> </ul>
<b>Laser ablated or drilled polymer</b>	Individual nozzle holes are ablated by an intense UV laser in a nozzle plate, which is typically a polymer such as polyimide or polysulphone	<ul style="list-style-type: none"> <li>◆ No masks required</li> <li>◆ Can be quite fast</li> <li>◆ Some control over nozzle profile is possible</li> <li>◆ Equipment required is relatively low cost</li> </ul>	<ul style="list-style-type: none"> <li>◆ Each hole must be individually formed</li> <li>◆ Special equipment required</li> <li>◆ Slow where there are many thousands of nozzles per print head</li> <li>◆ May produce thin burrs at exit holes</li> </ul>	<ul style="list-style-type: none"> <li>◆ Canon Bubblejet</li> <li>◆ 1988 Sercel et al., SPIE, Vol. 998 Excimer Beam Applications, pp. 76-83</li> <li>◆ 1993 Watanabe et al., USP 5,208,604</li> </ul>
<b>Silicon micro-machined</b>	A separate nozzle plate is micromachined from single crystal silicon, and bonded to the print head wafer.	<ul style="list-style-type: none"> <li>◆ High accuracy is attainable</li> </ul>	<ul style="list-style-type: none"> <li>◆ Two part construction</li> <li>◆ High cost</li> <li>◆ Requires precision alignment</li> <li>◆ Nozzles may be clogged by adhesive</li> </ul>	<ul style="list-style-type: none"> <li>◆ K. Bean, IEEE Transactions on Electron Devices, Vol. ED-25, No. 10, 1978, pp 1185-1195</li> <li>◆ Xerox 1990 Hawkins et al., USP 4,899,181</li> </ul>
<b>Glass capillaries</b>	Fine glass capillaries are drawn from glass tubing. This method has been used for making individual nozzles, but is difficult to use for bulk manufacturing of print heads with thousands of nozzles.	<ul style="list-style-type: none"> <li>◆ No expensive equipment required</li> <li>◆ Simple to make single nozzles</li> </ul>	<ul style="list-style-type: none"> <li>◆ Very small nozzle sizes are difficult to form</li> <li>◆ Not suited for mass production</li> </ul>	<ul style="list-style-type: none"> <li>◆ 1970 Zoltan USP 3,683,212</li> </ul>
<b>Monolithic, surface micro-machined using VLSI lithographic processes</b>	The nozzle plate is deposited as a layer using standard VLSI deposition techniques. Nozzles are etched in the nozzle plate using VLSI lithography and etching.	<ul style="list-style-type: none"> <li>◆ High accuracy (&lt;1 <math>\mu\text{m}</math>)</li> <li>◆ Monolithic</li> <li>◆ Low cost</li> <li>◆ Existing processes can be used</li> </ul>	<ul style="list-style-type: none"> <li>◆ Requires sacrificial layer under the nozzle plate to form the nozzle chamber</li> <li>◆ Surface may be fragile to the touch</li> </ul>	<ul style="list-style-type: none"> <li>◆ Silverbrook, EP 0771 658 A2 and related patent applications</li> <li>◆ IJ01, IJ02, IJ04, IJ11, IJ12, IJ17, IJ18, IJ20, IJ22, IJ24, IJ27, IJ28, IJ29, IJ30, IJ31, IJ32, IJ33, IJ34, IJ36, IJ37, IJ38, IJ39, IJ40, IJ41, IJ42, IJ43, IJ44</li> </ul>

<b>NOZZLE CLEARING METHOD</b>				
	<b>Description</b>	<b>Advantages</b>	<b>Disadvantages</b>	<b>Examples</b>
<b>Monolithic, etched through substrate</b>	The nozzle plate is a buried etch stop in the wafer. Nozzle chambers are etched in the front of the wafer, and the wafer is thinned from the back side. Nozzles are then etched in the etch stop layer.	<ul style="list-style-type: none"> <li>◆ High accuracy (&lt;1 μm)</li> <li>◆ Monolithic</li> <li>◆ Low cost</li> <li>◆ No differential expansion</li> </ul>	<ul style="list-style-type: none"> <li>◆ Requires long etch times</li> <li>◆ Requires a support wafer</li> </ul>	<ul style="list-style-type: none"> <li>◆ IJ03, IJ05, IJ06, IJ07, IJ08, IJ09, IJ10, IJ13, IJ14, IJ15, IJ16, IJ19, IJ21, IJ23, IJ25, IJ26</li> </ul>
<b>No nozzle plate</b>	Various methods have been tried to eliminate the nozzles entirely, to prevent nozzle clogging. These include thermal bubble mechanisms and acoustic lens mechanisms	<ul style="list-style-type: none"> <li>◆ No nozzles to become clogged</li> </ul>	<ul style="list-style-type: none"> <li>◆ Difficult to control drop position accurately</li> <li>◆ Crosstalk problems</li> </ul>	<ul style="list-style-type: none"> <li>◆ Ricoh 1995 Sekiya et al USP 5,412,413</li> <li>◆ 1993 Hadimioglu et al EUP 550,192</li> <li>◆ 1993 Elrod et al EUP 572,220</li> </ul>
<b>Trough</b>	Each drop ejector has a trough through which a paddle moves. There is no nozzle plate.	<ul style="list-style-type: none"> <li>◆ Reduced manufacturing complexity</li> <li>◆ Monolithic</li> </ul>	<ul style="list-style-type: none"> <li>◆ Drop firing direction is sensitive to wicking.</li> </ul>	<ul style="list-style-type: none"> <li>◆ IJ35</li> </ul>
<b>Nozzle slit instead of individual nozzles</b>	The elimination of nozzle holes and replacement by a slit encompassing many actuator positions reduces nozzle clogging, but increases crosstalk due to ink surface waves	<ul style="list-style-type: none"> <li>◆ No nozzles to become clogged</li> </ul>	<ul style="list-style-type: none"> <li>◆ Difficult to control drop position accurately</li> <li>◆ Crosstalk problems</li> </ul>	<ul style="list-style-type: none"> <li>◆ 1989 Saito et al USP 4,799,068</li> </ul>

<b>DROP EJECTION DIRECTION</b>				
	<b>Description</b>	<b>Advantages</b>	<b>Disadvantages</b>	<b>Examples</b>
<b>Edge ('edge shooter')</b>	Ink flow is along the surface of the chip, and ink drops are ejected from the chip edge.	<ul style="list-style-type: none"> <li>◆ Simple construction</li> <li>◆ No silicon etching required</li> <li>◆ Good heat sinking via substrate</li> <li>◆ Mechanically strong</li> <li>◆ Ease of chip handling</li> </ul>	<ul style="list-style-type: none"> <li>◆ Nozzles limited to edge</li> <li>◆ High resolution is difficult</li> <li>◆ Fast color printing requires one print head per color</li> </ul>	<ul style="list-style-type: none"> <li>◆ Canon Bubblejet 1979 Endo et al GB patent 2,007,162</li> <li>◆ Xerox heater-in-pit 1990 Hawkins et al USP 4,899,181</li> <li>◆ Tone-jet</li> </ul>
<b>Surface ('roof shooter')</b>	Ink flow is along the surface of the chip, and ink drops are ejected from the chip surface, normal to the plane of the chip.	<ul style="list-style-type: none"> <li>◆ No bulk silicon etching required</li> <li>◆ Silicon can make an effective heat sink</li> <li>◆ Mechanical strength</li> </ul>	<ul style="list-style-type: none"> <li>◆ Maximum ink flow is severely restricted</li> </ul>	<ul style="list-style-type: none"> <li>◆ Hewlett-Packard TIJ 1982 Vaught et al USP 4,490,728</li> <li>◆ IJ02, IJ11, IJ12, IJ20, IJ22</li> </ul>

<b>DROP EJECTION DIRECTION</b>				
	<b>Description</b>	<b>Advantages</b>	<b>Disadvantages</b>	<b>Examples</b>
<b>Through chip, forward ('up shooter')</b>	Ink flow is through the chip, and ink drops are ejected from the front surface of the chip.	<ul style="list-style-type: none"> <li>◆ High ink flow</li> <li>◆ Suitable for pagewidth print heads</li> <li>◆ High nozzle packing density therefore low manufacturing cost</li> </ul>	<ul style="list-style-type: none"> <li>◆ Requires bulk silicon etching</li> </ul>	<ul style="list-style-type: none"> <li>◆ Silverbrook, EP 0771 658 A2 and related patent applications</li> <li>◆ IJ04, IJ17, IJ18, IJ24, IJ27-IJ45</li> </ul>
<b>Through chip, reverse ('down shooter')</b>	Ink flow is through the chip, and ink drops are ejected from the rear surface of the chip.	<ul style="list-style-type: none"> <li>◆ High ink flow</li> <li>◆ Suitable for pagewidth print heads</li> <li>◆ High nozzle packing density therefore low manufacturing cost</li> </ul>	<ul style="list-style-type: none"> <li>◆ Requires wafer thinning</li> <li>◆ Requires special handling during manufacture</li> </ul>	<ul style="list-style-type: none"> <li>◆ IJ01, IJ03, IJ05, IJ06, IJ07, IJ08, IJ09, IJ10, IJ13, IJ14, IJ15, IJ16, IJ19, IJ21, IJ23, IJ25, IJ26</li> </ul>
<b>Through actuator</b>	Ink flow is through the actuator, which is not fabricated as part of the same substrate as the drive transistors.	<ul style="list-style-type: none"> <li>◆ Suitable for piezoelectric print heads</li> </ul>	<ul style="list-style-type: none"> <li>◆ Pagewidth print heads require several thousand connections to drive circuits</li> <li>◆ Cannot be manufactured in standard CMOS fabs</li> <li>◆ Complex assembly required</li> </ul>	<ul style="list-style-type: none"> <li>◆ Epson Stylus</li> <li>◆ Tektronix hot melt piezoelectric ink jets</li> </ul>

INK TYPE				
	Description	Advantages	Disadvantages	Examples
<b>Aqueous, dye</b>	Water based ink which typically contains: water, dye, surfactant, humectant, and biocide. Modern ink dyes have high water-fastness, light fastness	<ul style="list-style-type: none"> <li>◆ Environmentally friendly</li> <li>◆ No odor</li> </ul>	<ul style="list-style-type: none"> <li>◆ Slow drying</li> <li>◆ Corrosive</li> <li>◆ Bleeds on paper</li> <li>◆ May strikethrough</li> <li>◆ Cockles paper</li> </ul>	<ul style="list-style-type: none"> <li>◆ Most existing ink jets</li> <li>◆ All IJ series ink jets</li> <li>◆ Silverbrook, EP 0771 658 A2 and related patent applications</li> </ul>
<b>Aqueous, pigment</b>	Water based ink which typically contains: water, pigment, surfactant, humectant, and biocide. Pigments have an advantage in reduced bleed, wicking and strikethrough.	<ul style="list-style-type: none"> <li>◆ Environmentally friendly</li> <li>◆ No odor</li> <li>◆ Reduced bleed</li> <li>◆ Reduced wicking</li> <li>◆ Reduced strikethrough</li> </ul>	<ul style="list-style-type: none"> <li>◆ Slow drying</li> <li>◆ Corrosive</li> <li>◆ Pigment may clog nozzles</li> <li>◆ Pigment may clog actuator mechanisms</li> <li>◆ Cockles paper</li> </ul>	<ul style="list-style-type: none"> <li>◆ IJ02, IJ04, IJ21, IJ26, IJ27, IJ30</li> <li>◆ Silverbrook, EP 0771 658 A2 and related patent applications</li> <li>◆ Piezoelectric ink-jets</li> <li>◆ Thermal ink jets (with significant restrictions)</li> </ul>
<b>Methyl Ethyl Ketone (MEK)</b>	MEK is a highly volatile solvent used for industrial printing on difficult surfaces such as aluminum cans.	<ul style="list-style-type: none"> <li>◆ Very fast drying</li> <li>◆ Prints on various substrates such as metals and plastics</li> </ul>	<ul style="list-style-type: none"> <li>◆ Odorous</li> <li>◆ Flammable</li> </ul>	<ul style="list-style-type: none"> <li>◆ All IJ series ink jets</li> </ul>
<b>Alcohol (ethanol, 2-butanol, and others)</b>	Alcohol based inks can be used where the printer must operate at temperatures below the freezing point of water. An example of this is in-camera consumer photographic printing.	<ul style="list-style-type: none"> <li>◆ Fast drying</li> <li>◆ Operates at sub-freezing temperatures</li> <li>◆ Reduced paper cockle</li> <li>◆ Low cost</li> </ul>	<ul style="list-style-type: none"> <li>◆ Slight odor</li> <li>◆ Flammable</li> </ul>	<ul style="list-style-type: none"> <li>◆ All IJ series ink jets</li> </ul>
<b>Phase change (hot melt)</b>	The ink is solid at room temperature, and is melted in the print head before jetting. Hot melt inks are usually wax based, with a melting point around 80 °C. After jetting the ink freezes almost instantly upon contacting the print medium or a transfer roller.	<ul style="list-style-type: none"> <li>◆ No drying time-ink instantly freezes on the print medium</li> <li>◆ Almost any print medium can be used</li> <li>◆ No paper cockle occurs</li> <li>◆ No wicking occurs</li> <li>◆ No bleed occurs</li> <li>◆ No strikethrough occurs</li> </ul>	<ul style="list-style-type: none"> <li>◆ High viscosity</li> <li>◆ Printed ink typically has a 'waxy' feel</li> <li>◆ Printed pages may 'block'</li> <li>◆ Ink temperature may be above the curie point of permanent magnets</li> <li>◆ Ink heaters consume power</li> <li>◆ Long warm-up time</li> </ul>	<ul style="list-style-type: none"> <li>◆ Tektronix hot melt piezoelectric ink jets</li> <li>◆ 1989 Nowak USP 4,820,346</li> <li>◆ All IJ series ink jets</li> </ul>

<b>INK TYPE</b>				
	<b>Description</b>	<b>Advantages</b>	<b>Disadvantages</b>	<b>Examples</b>
<b>Oil</b>	Oil based inks are extensively used in offset printing. They have advantages in improved characteristics on paper (especially no wicking or cockle). Oil soluble dyes and pigments are required.	<ul style="list-style-type: none"> <li>◆ High solubility medium for some dyes</li> <li>◆ Does not cockle paper</li> <li>◆ Does not wick through paper</li> </ul>	<ul style="list-style-type: none"> <li>◆ High viscosity: this is a significant limitation for use in ink jets, which usually require a low viscosity. Some short chain and multi-branched oils have a sufficiently low viscosity.</li> <li>◆ Slow drying</li> </ul>	<ul style="list-style-type: none"> <li>◆ All IJ series ink jets</li> </ul>
<b>Micro-emulsion</b>	A microemulsion is a stable, self forming emulsion of oil, water, and surfactant. The characteristic drop size is less than 100 nm, and is determined by the preferred curvature of the surfactant.	<ul style="list-style-type: none"> <li>◆ Stops ink bleed</li> <li>◆ High dye solubility</li> <li>◆ Water, oil, and amphiphilic soluble dyes can be used</li> <li>◆ Can stabilize pigment suspensions</li> </ul>	<ul style="list-style-type: none"> <li>◆ Viscosity higher than water</li> <li>◆ Cost is slightly higher than water based ink</li> <li>◆ High surfactant concentration required (around 5%)</li> </ul>	<ul style="list-style-type: none"> <li>◆ All IJ series ink jets</li> </ul>

## I CLAIM

- 5 1. A camera system for recording images, said camera system comprising:  
an electronic image sensor for sensing an image;  
a digital processing means for processing said sensed image in accordance with  
predetermined processing requirements;  
a photo width ink jet printer means for printing said processed image on a  
surface of ink jet print media, said print media including a magnetic recording surface;  
10 a magnetic recording means for recording associated information on said  
magnetic recording surface.
2. A camera system as claimed in claim 1 wherein said associated information  
comprises audio information associated with said sensed image.
- 15 3. A camera system as claimed in claim 1 wherein the printer means prints said  
sensed image on a first surface of said print media and the magnetic recording means  
records said associated information on a second surface of said print media.
- 20 4. A camera system as claimed in claim 1 wherein said print media is stored on an  
internal detachable roll in said camera system, said camera system comprising a hand held  
portable camera device, said photo width ink jet printer being built into said hand held  
portable camera device.
5. A camera system as claimed in claim 3 wherein said first and said second  
surfaces are on different faces of said print media.

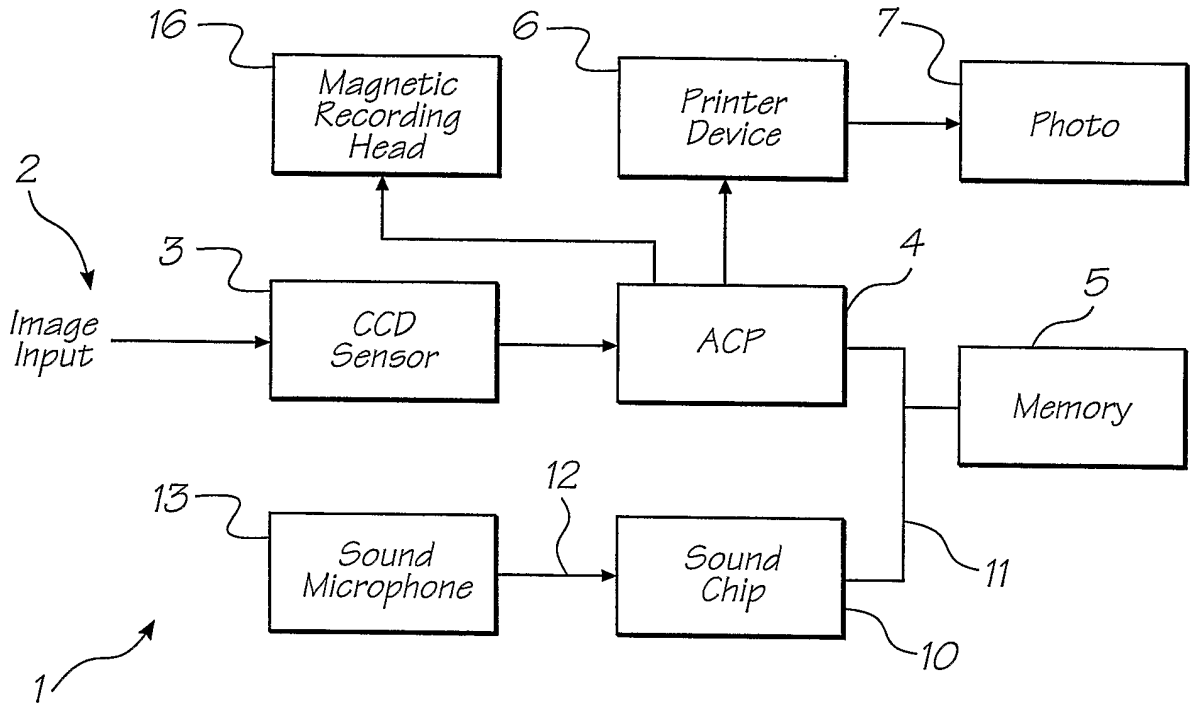

FIG. 1

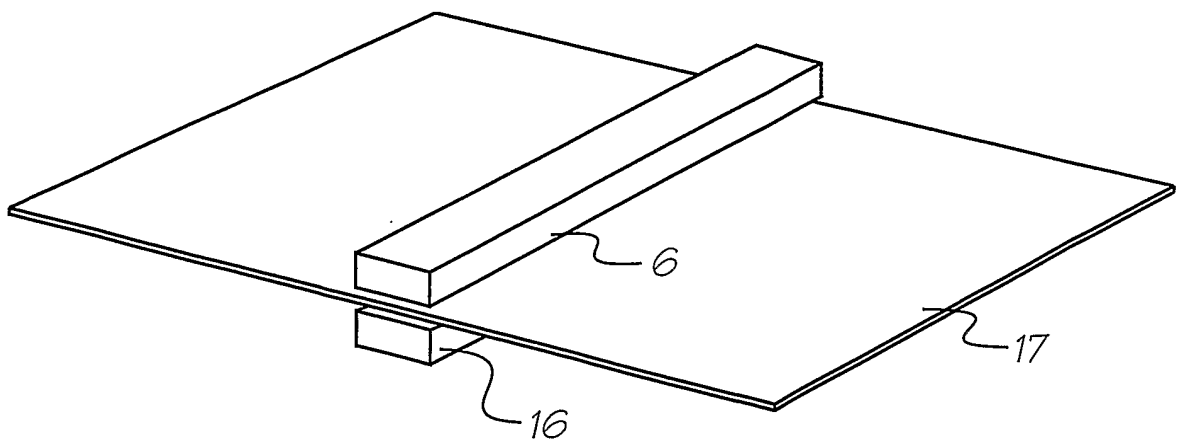

FIG. 2

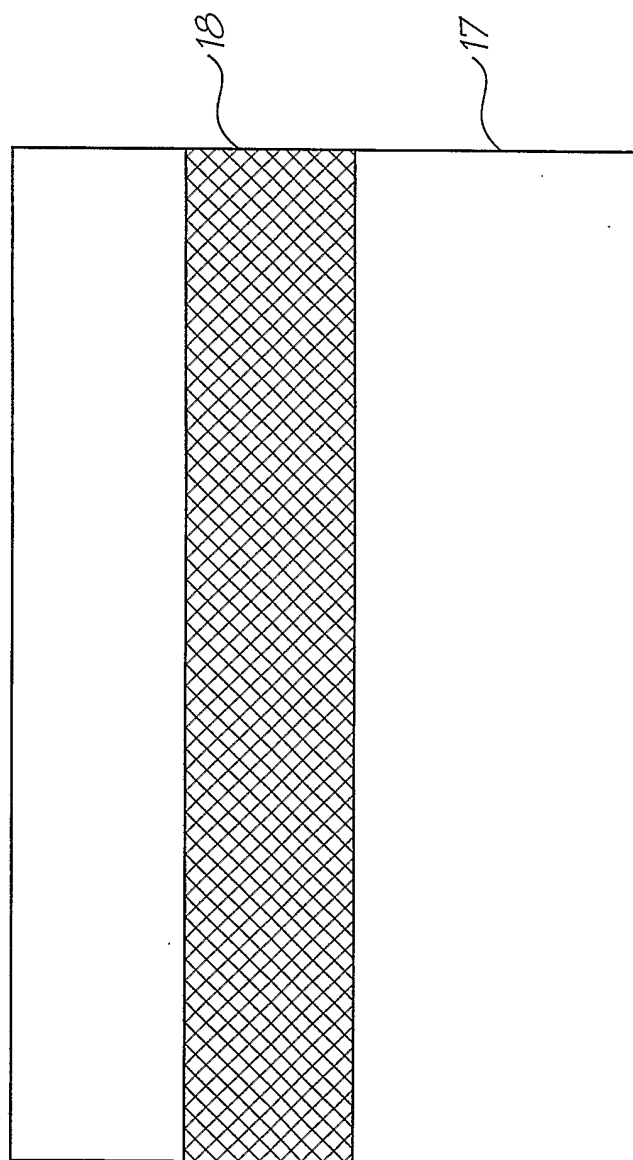

FIG. 3



3/4

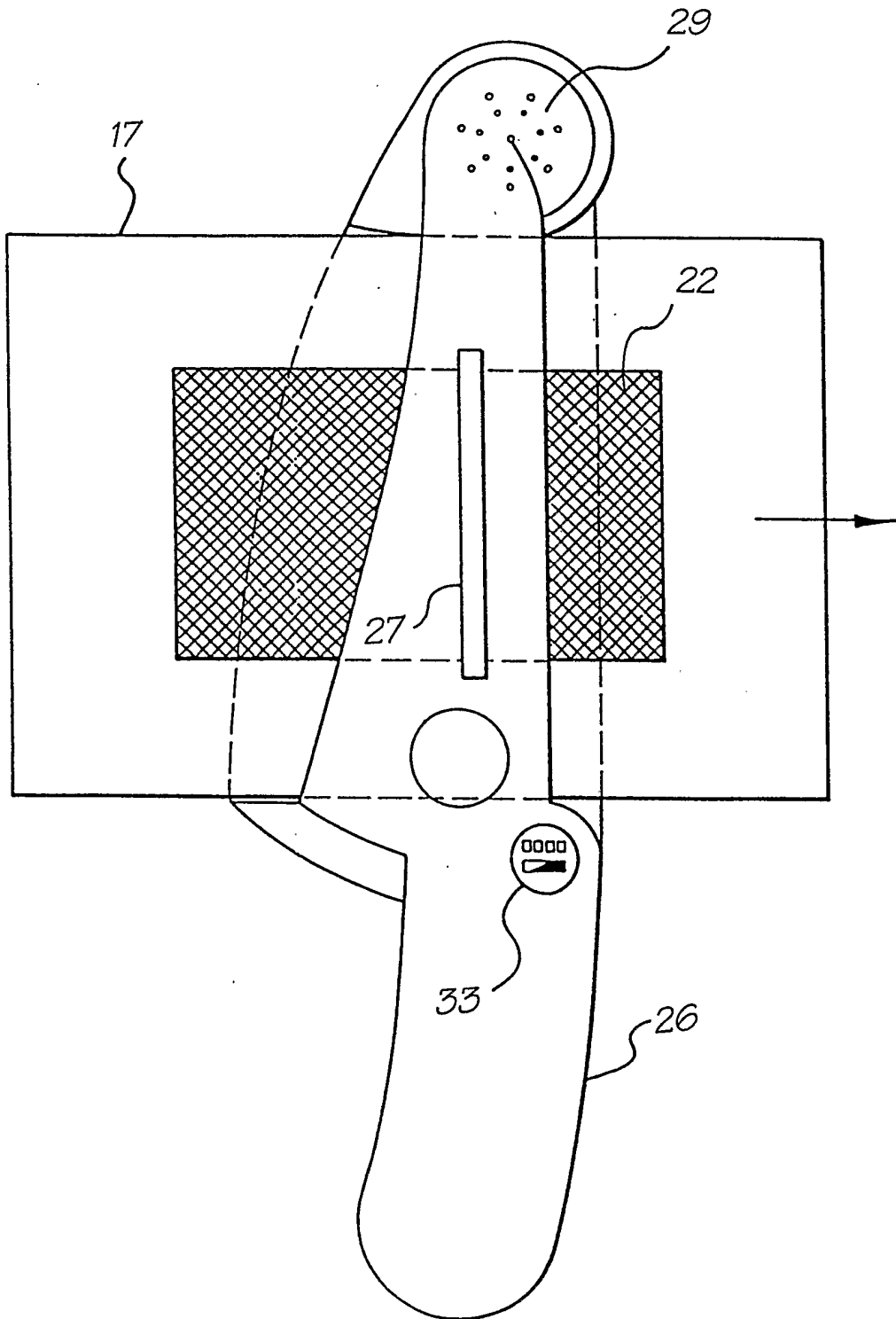

FIG. 4

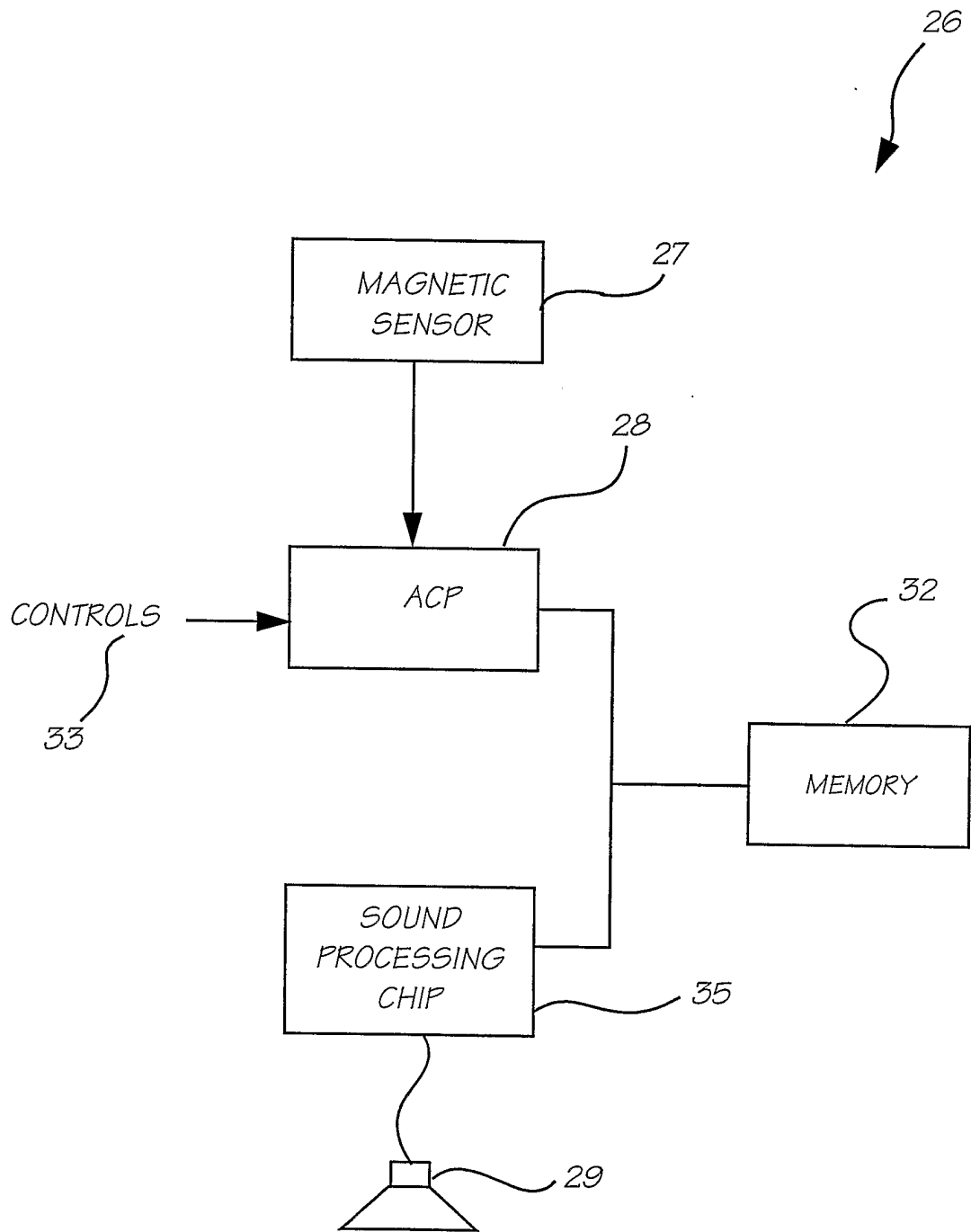

FIG. 5

# INTERNATIONAL SEARCH REPORT

International application No.  
**PCT/AU02/01161**

<b>A. CLASSIFICATION OF SUBJECT MATTER</b>																	
Int. Cl. <sup>7</sup> : G03B 19/02; H04N 5/225; G06K 19/10																	
According to International Patent Classification (IPC) or to both national classification and IPC																	
<b>B. FIELDS SEARCHED</b>																	
Minimum documentation searched (classification system followed by classification symbols)																	
Documentation searched other than minimum documentation to the extent that such documents are included in the fields searched																	
Electronic data base consulted during the international search (name of data base and, where practicable, search terms used) WPAT: camera, sensor, image, record, magnetic, print																	
<b>C. DOCUMENTS CONSIDERED TO BE RELEVANT</b>																	
Category*	Citation of document, with indication, where appropriate, of the relevant passages	Relevant to claim No.															
Y	US 2001/0030692-A1-(Yoneda) 18 October 2001 whole document	1-5															
Y	EP 1 039 351-A2-( Eastman Kodak Company) 27 September 2000 whole document	1-5															
Y	US 4,905,029-A-(Kelley) 27 February 1990 whole document	1-5															
	Note: US 4,905,029 can be combined with either of US 2001/0030692 or EP 1 039 351																
<input checked="" type="checkbox"/> Further documents are listed in the continuation of Box C <span style="margin-left: 100px;"><input checked="" type="checkbox"/> See patent family annex</span>																	
<p>* Special categories of cited documents:</p> <table style="width: 100%; border: none;"> <tr> <td style="width: 33%;">"A" document defining the general state of the art which is not considered to be of particular relevance</td> <td style="width: 33%;">"T" later document published after the international filing date or priority date and not in conflict with the application but cited to understand the principle or theory underlying the invention</td> <td style="width: 33%;"></td> </tr> <tr> <td>"E" earlier application or patent but published on or after the international filing date</td> <td>"X" document of particular relevance; the claimed invention cannot be considered novel or cannot be considered to involve an inventive step when the document is taken alone</td> <td></td> </tr> <tr> <td>"L" document which may throw doubts on priority claim(s) or which is cited to establish the publication date of another citation or other special reason (as specified)</td> <td>"Y" document of particular relevance; the claimed invention cannot be considered to involve an inventive step when the document is combined with one or more other such documents, such combination being obvious to a person skilled in the art</td> <td></td> </tr> <tr> <td>"O" document referring to an oral disclosure, use, exhibition or other means</td> <td>"&amp;" document member of the same patent family</td> <td></td> </tr> <tr> <td>"P" document published prior to the international filing date but later than the priority date claimed</td> <td></td> <td></td> </tr> </table>			"A" document defining the general state of the art which is not considered to be of particular relevance	"T" later document published after the international filing date or priority date and not in conflict with the application but cited to understand the principle or theory underlying the invention		"E" earlier application or patent but published on or after the international filing date	"X" document of particular relevance; the claimed invention cannot be considered novel or cannot be considered to involve an inventive step when the document is taken alone		"L" document which may throw doubts on priority claim(s) or which is cited to establish the publication date of another citation or other special reason (as specified)	"Y" document of particular relevance; the claimed invention cannot be considered to involve an inventive step when the document is combined with one or more other such documents, such combination being obvious to a person skilled in the art		"O" document referring to an oral disclosure, use, exhibition or other means	"&" document member of the same patent family		"P" document published prior to the international filing date but later than the priority date claimed		
"A" document defining the general state of the art which is not considered to be of particular relevance	"T" later document published after the international filing date or priority date and not in conflict with the application but cited to understand the principle or theory underlying the invention																
"E" earlier application or patent but published on or after the international filing date	"X" document of particular relevance; the claimed invention cannot be considered novel or cannot be considered to involve an inventive step when the document is taken alone																
"L" document which may throw doubts on priority claim(s) or which is cited to establish the publication date of another citation or other special reason (as specified)	"Y" document of particular relevance; the claimed invention cannot be considered to involve an inventive step when the document is combined with one or more other such documents, such combination being obvious to a person skilled in the art																
"O" document referring to an oral disclosure, use, exhibition or other means	"&" document member of the same patent family																
"P" document published prior to the international filing date but later than the priority date claimed																	
Date of the actual completion of the international search 10 September 2002		Date of mailing of the international search report 18 SEP 2002															
Name and mailing address of the ISA/AU AUSTRALIAN PATENT OFFICE PO BOX 200, WODEN ACT 2606, AUSTRALIA E-mail address: pct@ipaustralia.gov.au Facsimile No. (02) 6285 3929		Authorized officer  <b>JAMES WILLIAMS</b> Telephone No : (02) 6283 2599															

# INTERNATIONAL SEARCH REPORT

International application No.

**PCT/AU02/01161**

## C (Continuation). DOCUMENTS CONSIDERED TO BE RELEVANT

Category*	Citation of document, with indication, where appropriate, of the relevant passages	Relevant to claim No.
A	US 6,381,418-B1-(Spurr et al) 30 April 2002 whole document	1-5
A	US 6,363,239-B1-(Tutt et al) 26 March 2002 whole document	1-5

# INTERNATIONAL SEARCH REPORT

Information on patent family members

International application No.

**PCT/AU02/01161**

This Annex lists the known "A" publication level patent family members relating to the patent documents cited in the above-mentioned international search report. The Australian Patent Office is in no way liable for these particulars which are merely given for the purpose of information.

Patent Document Cited in Search Report		Patent Family Member	
US 20010030692	EP 1107278	JP 2001169437	
US 4905029	NONE		
US 6381418	EP 1076316	JP 2001143026	
US 6363239	EP 1079268	JP 2001119320	
EP 1 039 351	JP 2000307983		
END OF ANNEX			