



12

## EUROPEAN PATENT SPECIFICATION

45 Date of publication of patent specification :  
**19.10.94 Bulletin 94/42**

51 Int. Cl.<sup>5</sup> : **H01R 43/16**

21 Application number : **89304336.4**

22 Date of filing : **28.04.89**

54 **Electrical connector having preloaded terminals and method of manufacture.**

30 Priority : **28.02.89 GB 8904492**

43 Date of publication of application :  
**05.09.90 Bulletin 90/36**

45 Publication of the grant of the patent :  
**19.10.94 Bulletin 94/42**

84 Designated Contracting States :  
**DE ES FR GB IT NL**

56 References cited :  
**EP-A- 0 263 296**  
**US-A- 4 576 427**  
**US-A- 4 638 559**

73 Proprietor : **THE WHITAKER CORPORATION**  
**Suite 450,**  
**4550 New Linden Hill Road**  
**Wilmington, Delaware 19808 (US)**

72 Inventor : **Broeksteeg, Johannes Marcelus**  
**Hertogensingel 62**  
**NL-5341 AG Oss (NL)**

74 Representative : **Warren, Keith Stanley et al**  
**BARON & WARREN**  
**18 South End**  
**Kensington**  
**London W8 5BU (GB)**

**EP 0 385 019 B1**

Note : Within nine months from the publication of the mention of the grant of the European patent, any person may give notice to the European Patent Office of opposition to the European patent granted. Notice of opposition shall be filed in a written reasoned statement. It shall not be deemed to have been filed until the opposition fee has been paid (Art. 99(1) European patent convention).

## Description

This invention relates to a method of manufacturing edge stamped electrical terminals for an electrical connector for making electrical connection between a substrate having printed circuits thereon and further

conductive elements.  
A need exists in the electronics industry for a low height electrical connector for terminating flexible cable to printed circuit boards, and which allows for easy insertion and withdrawal of the flexible circuitry of the cable, the terminals of the connector being prestressed to allow of adequate contact force between the terminals and the flexible circuitry.

EP-A-0 263 296 discloses an electrical connector wherein a flexible circuit can be placed in a front face of the connector and interconnected to a printed circuit board. An upper cover is rotatable about a housing of the connector to lift the contacts of electrical terminals of the connector out of contact with each other. Although it is indicated in EP-A-0 263 296 that the terminals are prestressed, the terminals have no components for facilitating the preloading of the terminals.

It is an object of the invention to provide an easy and efficient method of providing prestressed electrical terminals.

According to one aspect thereof the present invention consists in a method as defined in claim 1.

EP-A-0 263 296 discloses the subject matter of the preamble of claim 1.

According to another aspect thereof the present invention consists in an electrical connector as defined in claim 4.

The preferred embodiment of the invention will now be described, by way of example, with reference to the accompanying drawings, in which:-

Figure 1 is an isometric view showing the cam member and the terminals assembled to the housing;

Figure 2 is an isometric view similar to that of Figure 1 showing the connector prior to the installation of the terminals and the cam member;

Figure 3 is an isometric view similar to that of Figures 1 and 2 showing a partial cut away view of the connector when the terminals are in an undeflected condition;

Figure 4 is an isometric view similar to that of Figure 3 showing the cam member in a fully rotated position with the contacts deflected and poised for receipt of a flat cable;

Figure 5 is a cross-sectional view through lines 5-5 of Figure 1;

Figure 6 is a cross-sectional view similar to that of Figure 5 absent the electrical terminal;

Figure 7 is a cross-sectional view through lines 7-7 of Figure 1;

Figure 8 is a cross-sectional view similar to that

of Figure 7 absent the hold down terminal.

Figure 9 is side plan view of the electrical terminal prior to the final formation;

Figure 10 is a side plan view of the electrical connector configured for surface mount applications;

Figure 11 is an isometric view similar to that of Figure 1 showing an optional shielded version;

Figure 12 is a cross-sectional view of an alternate embodiment where the connector is vertically arranged and for through hole printed circuit board mount; and

Figure 13 is a view similar to that of Figure 12 for surface board mounting of printed circuit boards.

With reference first to Figure 1, the electrical connector 2 of the present embodiment can interconnect electrical traces 202 of a flat flexible cable, such as 200 to a printed circuit board 210. The electrical connector 2 generally comprises a housing 4 holding a plurality of electrical terminals 150, and further comprises a cam member 100 which can be rotated in the counter-clockwise direction (as viewed in Figure 1) to deflect the terminals to a position where the flexible cable 200 can be inserted without an insertion force. This type of electrical connector is usually referred to as a zero insertion force or ZIF electrical connector.

With reference to Figure 2, the housing 4 will be described in greater detail. The housing 4 is generally comprised of an insulating material such as a glass filled thermoplastic and generally includes a top wall 6, a recessed surface 8, a rear surface 10, a lower mounting surface 12, side walls 14 and 16 and a front mating face 18. The housing further comprises a plurality of ribs 24 which extend from a position proximate the front face 18 to the rear surface 10. The profile of the ribs at the front edge is defined by slanted edges 26, and by a plurality of side by side semi-circular edges 28. The housing 4 further comprises a plurality of apertures 50 which are in side by side alignment with the terminal receiving cavities 54. The cavities 54 are defined by side surfaces 56 and 58 as shown in Figure 2.

With reference now to Figure 6, the internal features of the housing can be seen more clearly. The terminal receiving cavities 54 are defined by side surfaces 56 and 58 where the side surface 56 is co-planar with the side of the aperture 50 and with the side surfaces of the ribs 24. Although the side surface 56 is shown, due to the positioning of the cross-section, it should be appreciated that side surface 58 is a mirror image of the cross-section shown in Figure 6, and having the same co-planarity.

With reference now to Figures 4 and 6, the substrate receiving slot 20 can be seen as extending in a transverse direction across the front face 18 of the housing 4. The slot is defined by an upper surface 34 and a lower surface 40, and further defined by a plurality of elongate longitudinal ribs 36 and 42. The ribs 36 and 42 are alternately spaced according to the lo-

cation of the terminals as best shown in Figure 4, and help to align the vertical position of the substrate with the contact portions of the terminals. With reference again to Figure 2, the housing 4 includes apertures 84 therethrough for retaining the cam member 100 to the housing body. The apertures 84 are defined by two cut-out sections 80 and 82 which are laterally offset from one another and opening in opposite directions. Stated differently, the apertures 84 are created by two retractable mold parts which, when fully inserted, are flush to one another thereby forming the openings 84, and when retracted, they form the cut-out sections 80 and 82. With reference now to Figures 2 and 8, a further slot 70 is formed behind the cut-out 80 and is defined by surfaces 72 and 74. With reference to Figure 8, the webs 27 and 29 are shown, which retain the sidewalls 14 and 16 to the remainder of the housing body.

With reference to Figure 2, the cam member 100 includes a cylindrical portion 102 integral with a plate portion 110. The cam member 100 includes a plurality of side by side individual cam members 106 having arcuate surfaces 104 between each of the individual cam members 106. The plate member 110 includes an upper 114 and lower 112 surface, and a window 108 aligned with each of the cam members 106.

With reference now to Figure 9, a terminal 150 is shown as including a horizontal base section 152 having contact parts 172 and 174 extending therefrom in a vertical direction and a surface mount portion 176 extending in a horizontal direction from the base portion 152. The contact parts 172, 174 or 176 can be selectively retained depending on the type of electrical connection desired to the printed circuit board. A retention arm 168 extends from the front portion of the horizontal base section 152 and includes a first contact portion 166. A vertical leg 154 extends upwardly from the horizontal base portion 152 and is continuous through a U-shaped section 156 to a contact arm section 158. A lever arm 162 is continuous with the contact arm 158 and has at its lower section, a second contact portion 164.

To assemble the connector shown in Figure 2, the cam member 100 is inserted into the nest area 22 of the housing such that the end sections 116 of the cam member 100 reside within the apertures 84 in the housing sidewalls. As installed, the plate portion 110 of the cam member is rotatable between two positive stops, between the positions where the lower surface 112 of the plate portion is in contact with the upper surface 32 of the platform 30 and, to a position where the surface 114 of the plate portion 110 is in abutting relation with the slanted surfaces 26 of the housing.

The terminal is then stamped to the configuration shown in Figure 9 including all three legs 172, 174 and 176, and with the retention arm 168 and contact portion 166 extending at an acute angle relative to the horizontal base section 152. The terminals can then

be plated to provide an electrically conductive surface at the contact points 164 and 166. It should be noted that when the terminal is stamped into the configuration of Figure 9, the contact points 164 and 166 are separated a sufficient distance that the terminals can be adequately plated along the sheared edges of the contacts. Subsequent to the plating process, the retention arm 168 and contact point 166 are rotated in the counterclockwise direction (as viewed in Figure 9) until the contact point 166 moves into contact with the opposed contact section 164, and is further rotated until the contact portion 164 is slightly deflected thereby preloading the opposed contact portions 164 and 166 together. It should be noted that the section 170 of the terminal is of a reduced cross section relative to the remainder of the terminal which facilitates the bending of the terminal at the precise desired location, and without undue stresses causing cracking. It should also be noted that in the preferred embodiment, the desired material for use with the terminals is a phosphor-bronze alloy which can accommodate such bending. In the preferred embodiment of the invention, the plating is tin plating which has been found to be pliable enough to bend at the section 170 without cracking. Even if some cracking is present, the point which is rotated, that is about point 170, is remote from the contact area and will not effect the electrical characteristics.

After the contacts 150 are formed into their prestressed position as mentioned above, the terminals can be stamped to accommodate either a through hole soldered connection or a surface mount connection. In the preferred embodiment of the through hole soldered connector, the soldered leads are staggered to provide a closer center line spacing of the edge stamped contacts. Thus, while referring to Figure 9, every other contact 150 would include a solder leg 172 whereas the remainder of the alternate contacts would include a through hole solder leg 174. In the event that a surface mount connector is desired, then each of the solder legs 172 and 174 are sheared clean of the stamped terminal and the surface mount lead 176 is retained.

With the terminals stamped and formed as desired, the terminals 150 are insertable into the electrical housing as shown in Figure 5. The retention arm 168 is receivable into the aperture 50 of the housing and interference fit to retain the terminals in position. Since the retention arm 168 is fixedly mounted within the aperture 50 and with the edge 178 in contact with the lower surface 51 of the aperture 50 as shown in Figure 5, the opposed contact portions 164, 166 (Figure 9) will be retained in a prestressed condition. Said differently, the retention arm 168 will have a tendency, when not loaded in the housing, to relieve its original prestressed condition, by rotating in a clockwise direction about pivot point 170. However, the retention arm 168 and the horizontal base section 152 are

being rigidly held in a fixed linear position by the aperture 50 which precludes the relaxation between the two opposed portions 164 and 166.

The camming feature, as described herein, has proven to be quite advantageous for use with such small components. For example, the housing shown in Figure 2 has a height between surfaces 6 and 12 of only 4 millimeters, and the flat flexible cable which in interconnectable to the connector can vary between 0.1 and 0.3 millimeters, with the conductive elements on the cable at centerlines of only 0.0635 cm (0.025 inches). The first advantage, given the lowest height of the electrical connector, is that an actuator can be used which does not substantially increase the length of the overall connector. This has been accomplished by designing the cam member to have a very high mechanical advantage due to the large rotation angle of the camming member between the two stops as previously described. In order to achieve this high mechanical advantage, windows 108 are provided in the plate member in alignment with each of the cam members. After the lever arm 162 passes over the cam surface 106, the lever arm 162 actually passes through the windows 108 increasing the rotation angle of the camming member, and resultantly, the mechanical advantage.

The windows 108 also provide for the second advantage, that when the cam member 100 is rotated to its full upright position to a position where the levers 162 project through the windows 108 as shown in Figure 4, the spring force on the upper contact arm 158 due to its deflected position bears on the cam member retaining the cam member in an upward position. This force holds the cam actuator 100 in position, which also holds the contacts to a deflected condition poised for insertion of the cable. This simplifies the ease of insertion of the flat flexible cable given the small space available for access to these connectors. In fact, this detented position allows for insertion of the cable with the use of one hand only, which is sometimes all that there is room for, in these densely filled printed circuit boards.

A third advantage of the camming feature is that a rib 26 is positioned within each of the circular sections 104 which in turn positions each of the cam members 106 within one of the recesses 54 which retains the cam members 106 in side to side alignment with the lever portions 162 of the terminals. This ensures that the lever portions are retained within the recesses 54 and in alignment with the cam portions 105.

As mentioned above, the connector has been designed for either through hole or surface mounting. When the connector will be used in a surface mount application, a retention feature 200 is used, as shown in Figures 1, 2 and 7, which is insertable into the recess 70 and can be latched in place. As best seen in Figure 7, the retention member 200 includes two bi-

furcate arms 202 where the lower arm has a latching shoulder, which when in the fully inserted position, can be latched behind a shoulder 204 of the web 29. The retention member 200 includes a foot which can then be soldered to the board which retains the connector in position on the board. It should also be mentioned that a through hole post could also be provided extending from the retention member which is soldered or otherwise latched to the printed circuit board.

As shown in Figure 11, a shielded version is available, where the same housing is used for both the shielded and unshielded version. As shown in Figure 11, an optional shield member 300 can be added to the connector 2, which comprises an upper shield wall 302 and shielding sidewalls 304. A rear shield wall is also provided which extends between the upper wall 302 and between the sidewalls 304, although due to the angle of the isometric view of Figure 11, the rear wall cannot be seen. To retain the shield to the connector housing 4, two retention arms 308 are provided, which are sheared away from the sidewalls 304 about shear lines 306. The ends of the retention arms 308 include latching features 310 identical to the latching features 202 (Figure 7), and can be latched to the latching shoulder 204 as shown in Figure 11. It should be noted that the availability of the shielding version is quite advantageous, and is due to the quite efficient design of the electrical connector shown in Figure 1. For example, due to the very efficient camming member 100, the camming member is very small dimensionally when compared to the rest of the connector housing. Also, the camming member only operates in a very small portion of the connector housing, leaving the rest of the connector housing to be shielded. It should be appreciated that the shield member shown in Figure 11 could also include such features as through hole posts which are connectable to ground traces on the printed circuit boards.

As shown in Figures 12 and 13, although the horizontal version shown in Figures 1-10 is the preferred version, again due to the efficient design of the electrical connector, a vertical version of the connector is available which can be formed by using the same housing as the horizontal version. All that needs to be changed is the terminal configuration as shown in Figures 12 and 13.

Thus, with the efficient design of the electrical connector, the exact same housing can be used with several differently configured systems. For example, the cam member of the electrical connector is very small relative to the remainder of the connector due to the high mechanical advantage of the connector. Furthermore, the connector can be configured as a horizontal through hole version, a horizontal surface mount version, a vertical through hole version or a vertical surface mount version. Also, the terminals are designed such that the same stamping for the hor-

izontal version, and the same terminal stamping for the vertical version can be used to make either the through hole or surface mount connector. Finally, any of the above mentioned configurations can be electrically shielded.

### Claims

1. A method of manufacturing edge stamped electrical terminals (150) for an electrical connector for making an electrical connection between a substrate (210) having printed circuits thereon, and further conductive elements (202) wherein the connector (2) includes an insulating housing (4) comprising a plurality of terminal passageways (56) for receiving a plurality of said edge stamped electrical terminals (150), and wherein the electrical terminals (150) have opposed contact members (164,166) which effect the electrical connection with the further conductive elements (202), the method comprising the step of:
  - edge stamping the terminals (150) to provide a horizontal base portion (152) with a spring arm (158) extending upwardly from the horizontal base portion (152), and an extension arm (168) extending away from the spring arm (158), the extension arm (168) having a first contact member (166) extending upwardly therefrom towards the spring arm (158), and the spring arm (158) having a second contact member (164) thereon, which is spaced from the first contact member (166); characterized by the further steps of;
    - providing the extension arm (168) so that it extends in the opposite direction to the spring arm (158) and at an acute angle relative to the base portion (152), such that the first contact member (166) is initially remote from the second contact member (164); and
    - subsequently bending the extension arm (168), by plastically deforming a connecting section (170) between the extension arm (168) and the base portion (152), to move the extension arm (168) towards the spring arm (158) to a new position in which the first (166) and second (164) contact members are in an opposed and facing relation.
2. A method according to claim 1, characterized in that subsequent to the edge stamping step, but prior to the step of bending the extension arm (168), the first (166) and second (164) contact members are plated.
3. A method according to claim 1 or 2, characterized in that the extension arm (168) is bent towards the spring arm (158) to an extent to preload the first (166) and second (164) contact members

against each other.

4. An electrical connector having edge stamped terminals (150) manufactured according to the method defined by any one of claims 1 to 3, characterized in that the housing (4) has a plurality of apertures (50) extending in the housing (4), and receiving the extension arms (168).
5. An electrical connector according to claim 4, characterized in that a substrate receiving slot (20) is defined by means integral with the housing (4) and extends above and transverse to the apertures (50).
6. An electrical connector according to claim 4 or 5, characterized in that the terminal receiving passageways (56) are defined by a floor (51) which extends forwardly to the apertures (50).
7. An electrical connector according to claim 6, characterized in that the lower edge (178) of the horizontal base portion (152) is in abutment with the floor (51).
8. An electrical connector according to any one of the preceding claims, characterized in that said connecting section of each of the terminals (150) is of reduced cross section (170) to facilitate said bending.
9. An electrical connector according to claim 6, characterized in that the floor (51) extends behind the connecting sections (170) of the terminals (150).
10. An electrical connector according to claim 4, 5 or 6, characterized in that the upper edges of the extension arms (168) are in abutment with the upper surfaces of the apertures (50), thereby preventing anti-rotation of the extension arm (168) relative to the horizontal base portion (152).

### Patentansprüche

1. Verfahren zum Herstellen kantengestanzter elektrischer Anschlüsse (150) für einen elektrischen Verbinder zum Herstellen einer elektrischen Verbindung zwischen einem Substrat (210), das gedruckte Schaltkreise trägt, und weiteren leitfähigen Elementen, (202), wobei der Verbinder (2) ein isolierendes Gehäuse (4) umfaßt, das eine Vielzahl von Anschlußdurchgängen (56) zur Aufnahme einer Vielzahl der kantengestanzten elektrischen Anschlüsse (150) aufweist, und wobei die elektrischen Anschlüsse (150) gegenüberliegende Kontaktglieder (164, 166) haben, die die

elektrische Verbindung mit den weiteren leitfähigen Elementen (202) bewirken, wobei das Verfahren den folgenden Schritt aufweist:

- Kantenstanzen der Anschlüsse (150) zur Bildung eines waagerechten Hauptteils (152) mit einem Federarm (158), der sich von dem Hauptteil (152) nach oben erstreckt, und mit einem Verlängerungsarm (168), der sich von dem Federarm (158) weg erstreckt, wobei der Verlängerungsarm (168) ein erstes Kontaktglied (166) hat, das sich davon nach oben auf den Federarm (158) zu erstreckt, und wobei der Federarm (158) ein zweites Kontaktglied (164) trägt, das von dem ersten Kontaktglied (166) beabstandet ist,

**gekennzeichnet** durch die weiteren Schritte

- Ausbilden des Verlängerungsarmes (168) derart, daß er sich in der entgegengesetzten Richtung wie der Federarm (158) und unter einem spitzen Winkel in bezug auf den Hauptteil (152) erstreckt, so daß das erste Kontaktglied (166) anfänglich von dem zweiten Kontaktglied (164) entfernt ist, und

- anschließendes Biegen des Verlängerungsarms (168) durch plastisches Verformen eines Verbindungsabschnitts (170) zwischen dem Verlängerungsarm (168) und dem Hauptteil (152), um den Verlängerungsarm (168) auf den Federarm (158) zu in eine neue Position zu bewegen, in der das erste Kontaktglied (166) und das zweite Kontaktglied (164) einander gegenüber liegen und aufeinander zu weisen.

2. Verfahren nach Anspruch 1, **dadurch gekennzeichnet**, daß anschließend an den Schritt des Kantenspannens, aber vor dem Schritt des Biegens des Verlängerungsarms (168), das erste Kontaktglied (166) und das zweite Kontaktglied (164) plattiert werden.

3. Verfahren nach Anspruch 1 oder 2, **dadurch gekennzeichnet**, daß der Verlängerungsarm (168) auf den Federarm (158) zu in einem Maß gebogen wird, daß das erste Kontaktglied (166) und das zweite Kontaktglied (164) gegeneinander vorgespannt werden.

4. Elektrischer Verbinder mit kantengestanzten Anschlüssen (150), die nach dem Verfahren gemäß einem der Ansprüche 1 bis 3 hergestellt sind, **dadurch gekennzeichnet**, daß das Gehäuse (4) eine Vielzahl von Öffnungen (50) hat, die sich in dem Gehäuse (4) erstrecken und die Verlängerungsarme (168) aufnehmen.

5. Elektrischer Verbinder nach Anspruch 4, **dadurch gekennzeichnet**, daß ein Substrataufnahme-

schlitz (20) durch Mittel gebildet ist, die mit dem Gehäuse (4) einstückig sind, und der sich oberhalb und quer zu den Öffnungen (50) erstreckt.

6. Elektrischer Verbinder nach Anspruch 4 oder 5, **dadurch gekennzeichnet**, daß die Anschlußaufnahmedurchgänge (56) durch einen Boden (51) gebildet sind, der sich nach vorn zu den Öffnungen (50) erstreckt.

7. Elektrischer Verbinder nach Anspruch 6, **dadurch gekennzeichnet**, daß die untere Kante (178) des waagerechten Hauptteils (152) in Anlage mit dem Boden (51) ist.

8. Elektrischer Verbinder nach einem der vorhergehenden Ansprüche, **dadurch gekennzeichnet**, daß der Verbindungsabschnitt jedes der Anschlüsse (150) einen verminderten Querschnitt (170) hat, um das Biegen zu erleichtern.

9. Elektrischer Verbinder nach Anspruch 6, **dadurch gekennzeichnet**, daß der Boden (51) sich hinter den Verbindungsabschnitten (170) der Anschlüsse (150) erstreckt.

10. Elektrischer Verbinder nach Anspruch 4, 5 oder 6, **dadurch gekennzeichnet**, daß die oberen Kanten der Verlängerungsarme (168) in Anlage mit den oberen Oberflächen der Öffnungen (50) sind, wodurch eine Gegenverdrehung des Verlängerungsarms (168) relativ zu dem waagerechten Hauptteil (152) verhindert ist.

## Revendications

1. Procédé de fabrication de bornes électriques (150) à bords découpés pour un connecteur électrique pour la réalisation d'une connexion électrique entre un substrat (210) portant des circuits imprimés, et d'autres éléments conducteurs (202), le connecteur (2) comprenant un boîtier isolant (4) présentant plusieurs passages (56) pour bornes destinés à recevoir plusieurs desdites bornes électriques (150) à bords découpés, et les bornes électriques (150) ayant des éléments de contact opposés (164, 166) qui réalisent la connexion électrique avec les autres éléments conducteurs (202), le procédé comprenant l'étape qui consiste :

à découper les bords des bornes (150) pour produire une partie de base horizontale (152), avec un bras à ressort (158) s'étendant vers le haut depuis la partie de base horizontale (152), et un bras en extension (168) s'étendant à l'écart du bras à ressort (158), le bras en extension (168) ayant un premier élément de contact

- (166) qui en part vers le haut en direction du bras à ressort (158), et le bras à ressort (158) portant un second élément de contact (164), qui est espacé de la première élément de contact (166) ; caractérisé par les autres étapes qui consistent :
- 5 à placer le bras en extension (168) de manière qu'il s'étende dans la direction opposée au bras à ressort (158) et en formant un angle aigu avec la partie de base (152), afin que le premier élément de contact (166) soit initialement éloigné du second élément de contact (164) ; et
  - 10 à courber ensuite le bras en extension (168), par déformation plastique d'une partie (170) de liaison entre le bras en extension (168) et la partie de base (152), pour déplacer le bras en extension (168) vers le bras à ressort (158) jusqu'à une nouvelle position dans laquelle les premier (166) et second (164) éléments de contact sont dans une disposition opposée et face à face.
2. Procédé selon la revendication 1, caractérisé en ce que, après l'étape de découpage des bords, mais avant l'étape consistant à courber le bras en extension (168), les premier (166) et second (164) éléments de contact sont revêtus. 25
3. Procédé selon la revendication 1 ou 2, caractérisé en ce que le bras en extension (168) est courbé vers le bras à ressort (158) suffisamment pour précharger les première (166) et seconde (164) éléments de contact l'une contre l'autre. 30
4. Connecteur électrique comportant des bornes (150) à bords découpés fabriquées selon le procédé défini par l'une quelconque des revendications 1 à 3, caractérisé en ce que le boîtier (4) présente plusieurs ouvertures (50) s'étendant dans le boîtier (4) et recevant les bras en extension (168). 35 40
5. Connecteur électrique selon la revendication 4, caractérisé en ce qu'une fente (20) de réception de substrat est définie par des moyens réalisés d'une seule pièce avec le boîtier (4) et s'étend au-dessus des ouvertures (50) et transversalement à celles-ci. 45
6. Connecteur électrique selon la revendication 4 ou 5, caractérisé en ce que les passages (56) de réception de borne sont définis par un fond (51) qui s'étend vers l'avant jusqu'aux ouvertures (50). 50
7. Connecteur électrique selon la revendication 6, caractérisé en ce que le bord inférieur (178) de la partie de base horizontale (152) est en butée avec le fond (51). 55
8. Connecteur électrique selon l'une quelconque des revendications précédentes, caractérisé en ce que ladite partie de liaison de chacune des bornes (150) est d'une section transversale réduite (170) pour faciliter ladite courbure.
9. Connecteur électrique selon la revendication 6, caractérisé en ce que le fond (51) s'étend en arrière des parties (170) de liaison des bornes (150).
10. Connecteur électrique selon la revendication 4, 5 ou 6, caractérisé en ce que les bords supérieurs des bras (168) en extension sont en butée avec les surfaces supérieures des ouvertures (50), empêchant ainsi une contre-rotation du bras en extension (168) par rapport à la partie de base horizontale (152).

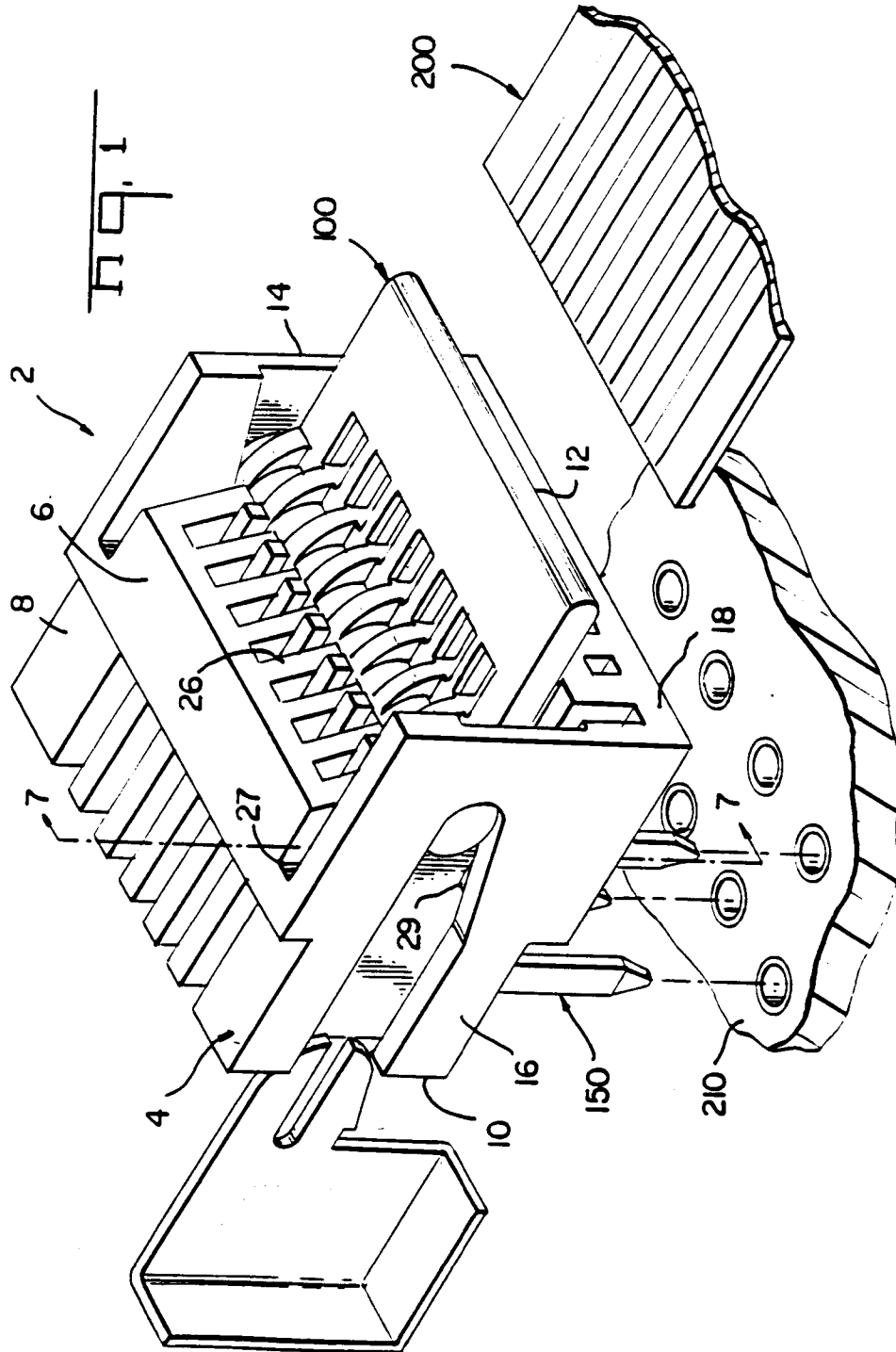

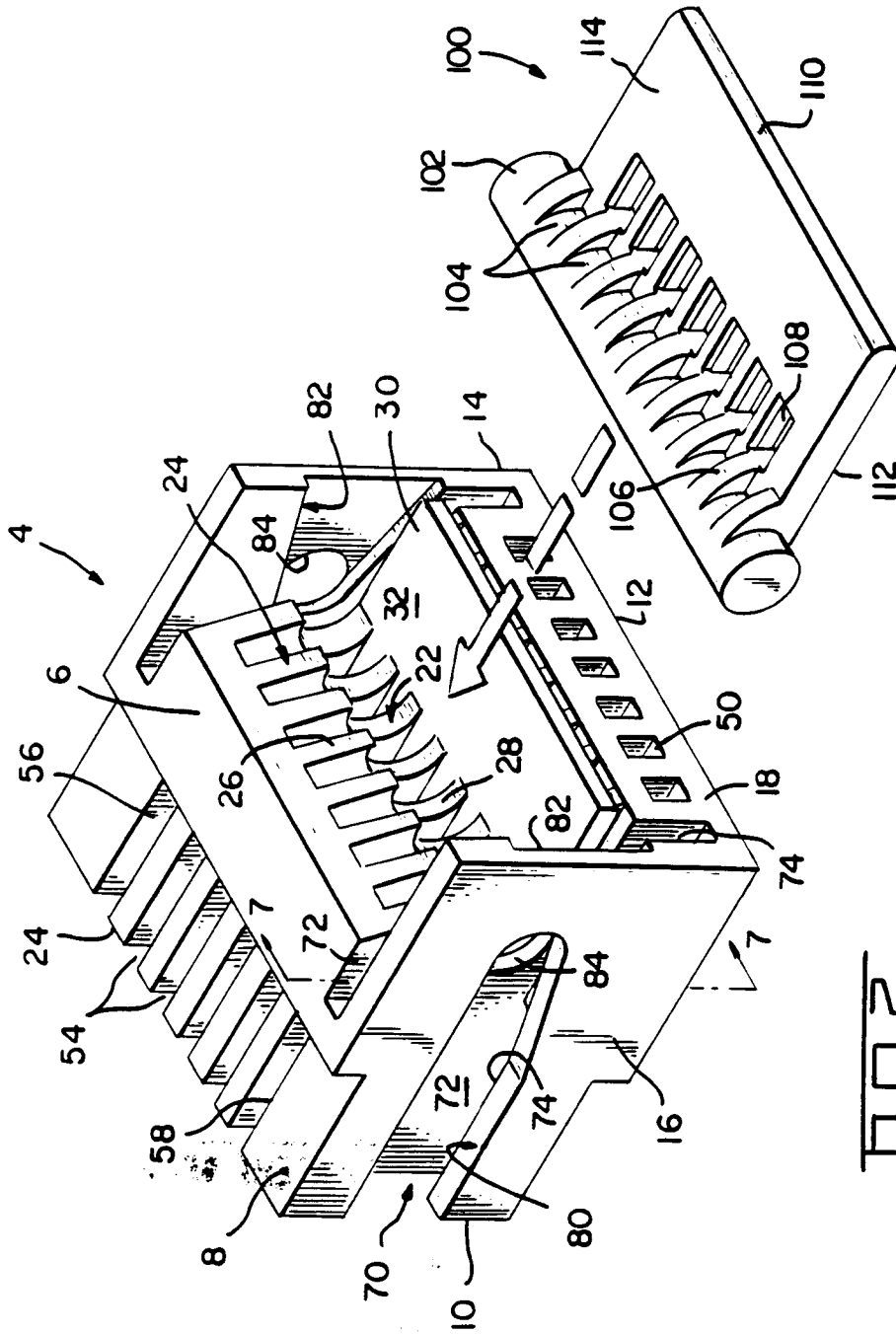
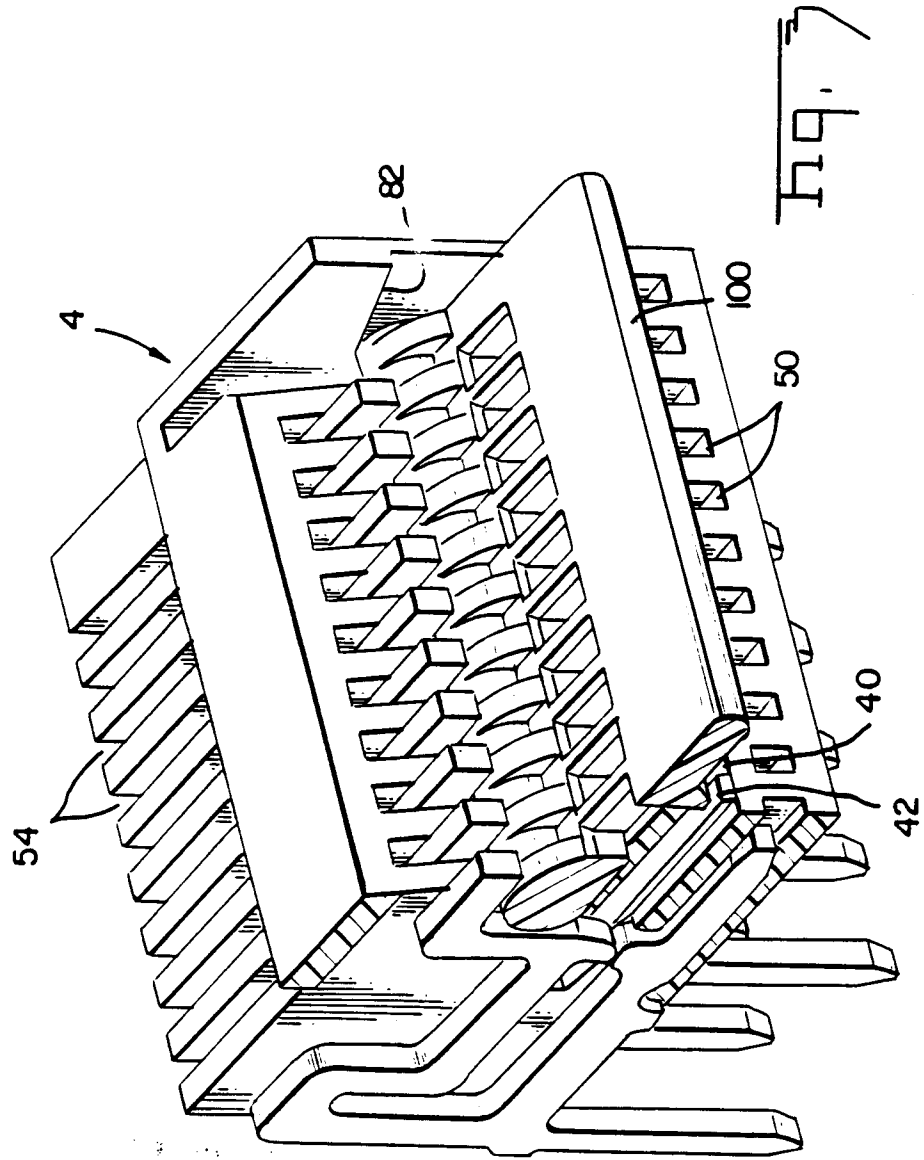
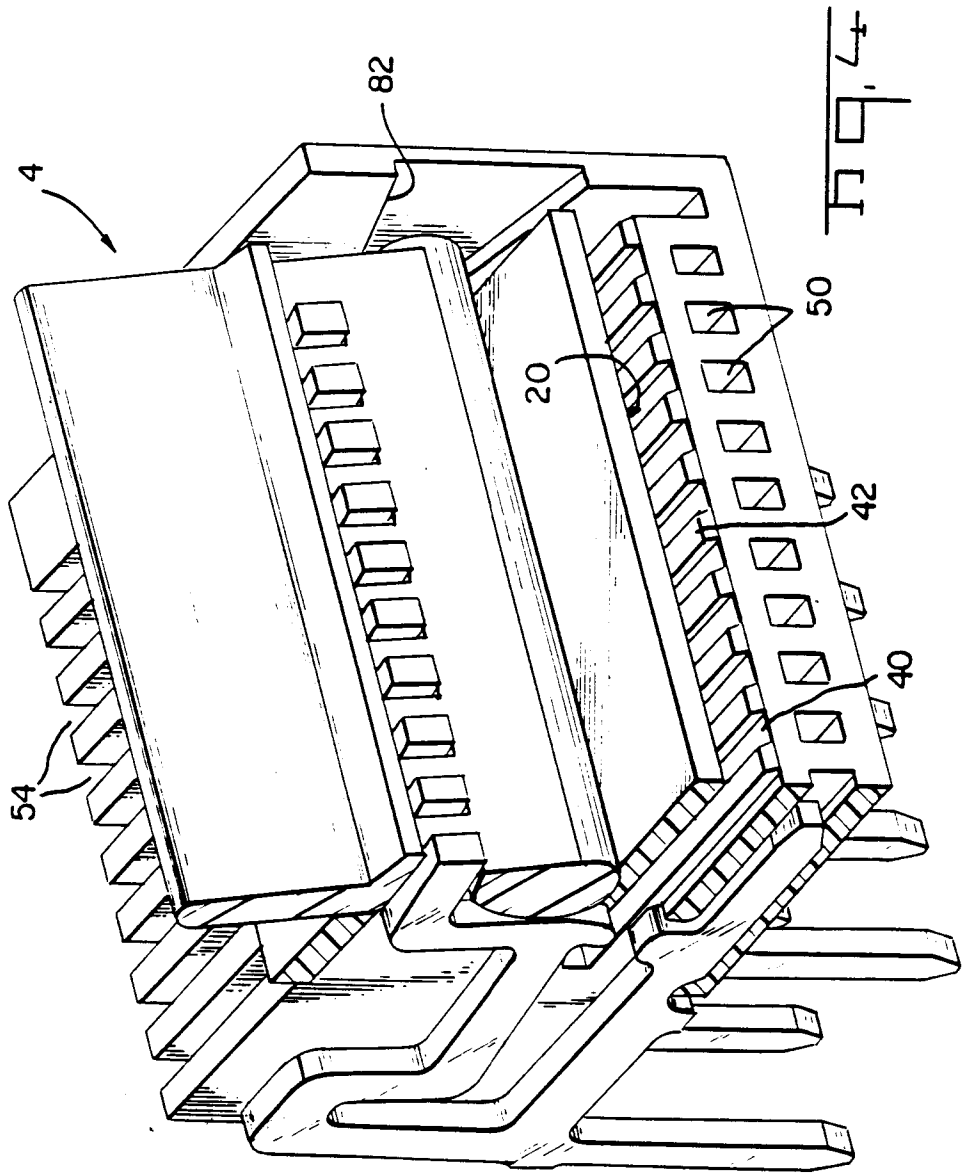

Fig. 2





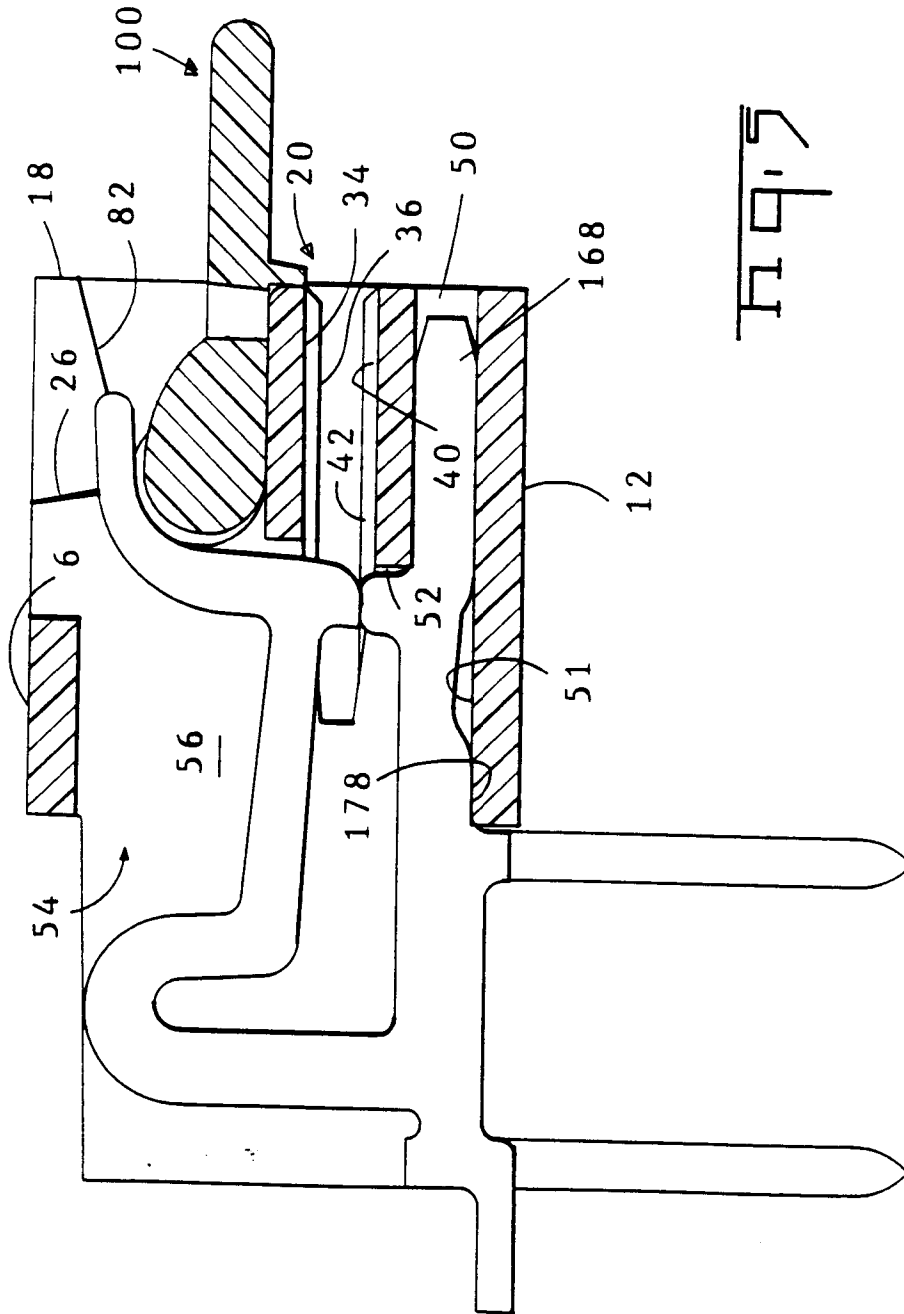
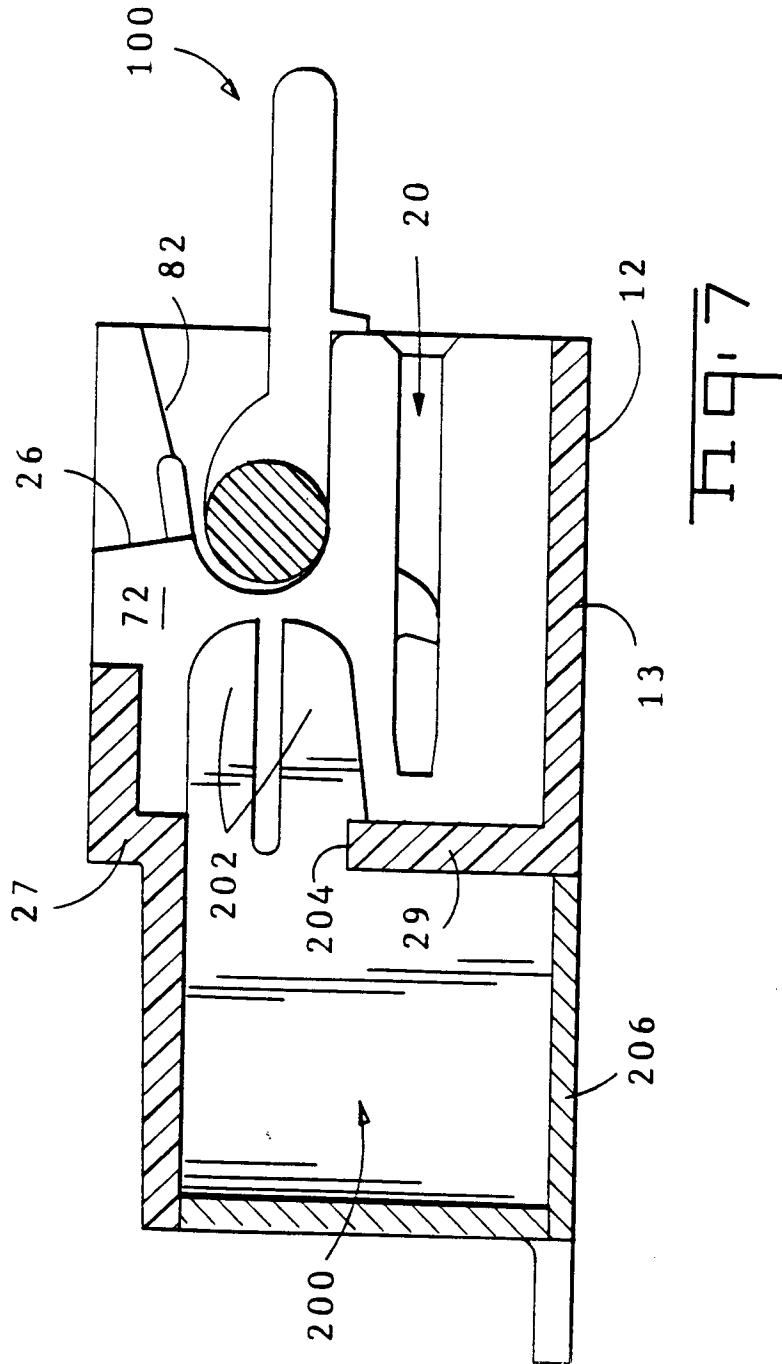
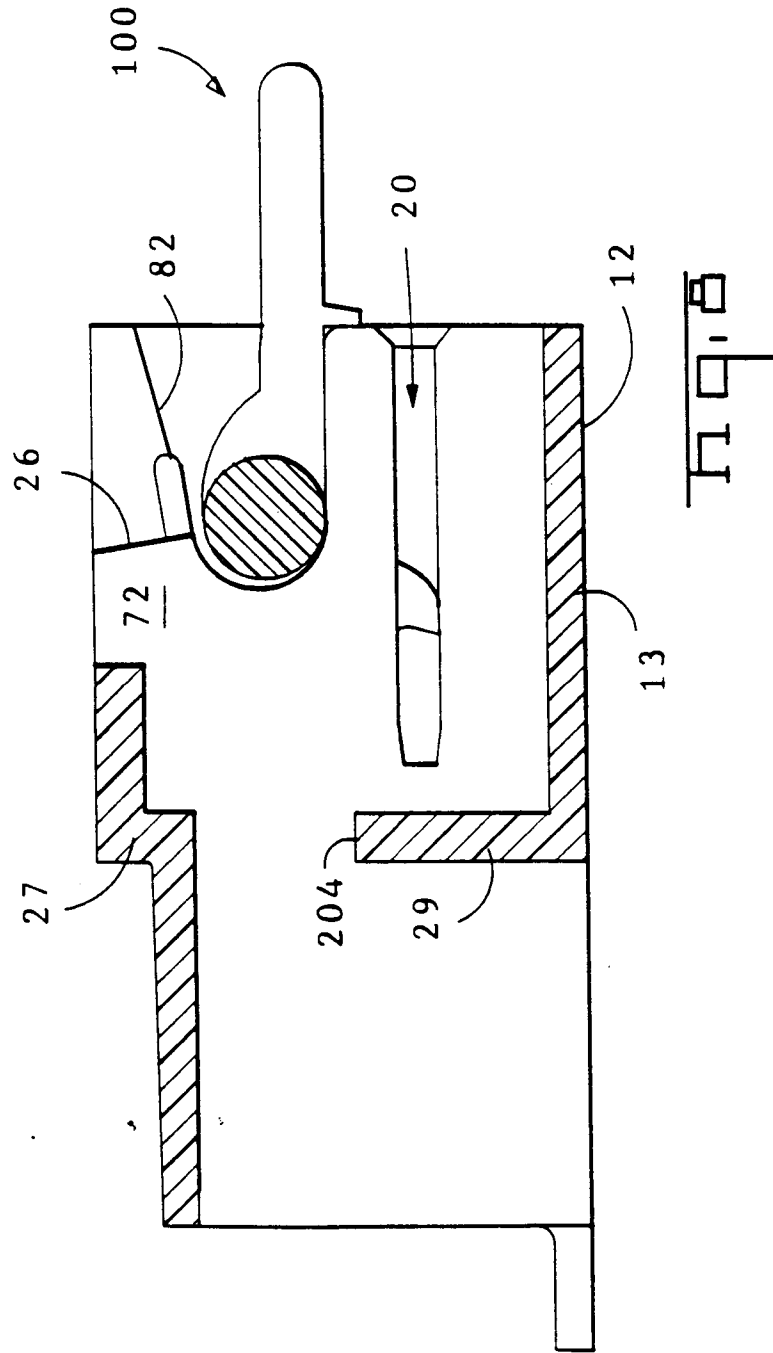

Fig. 5







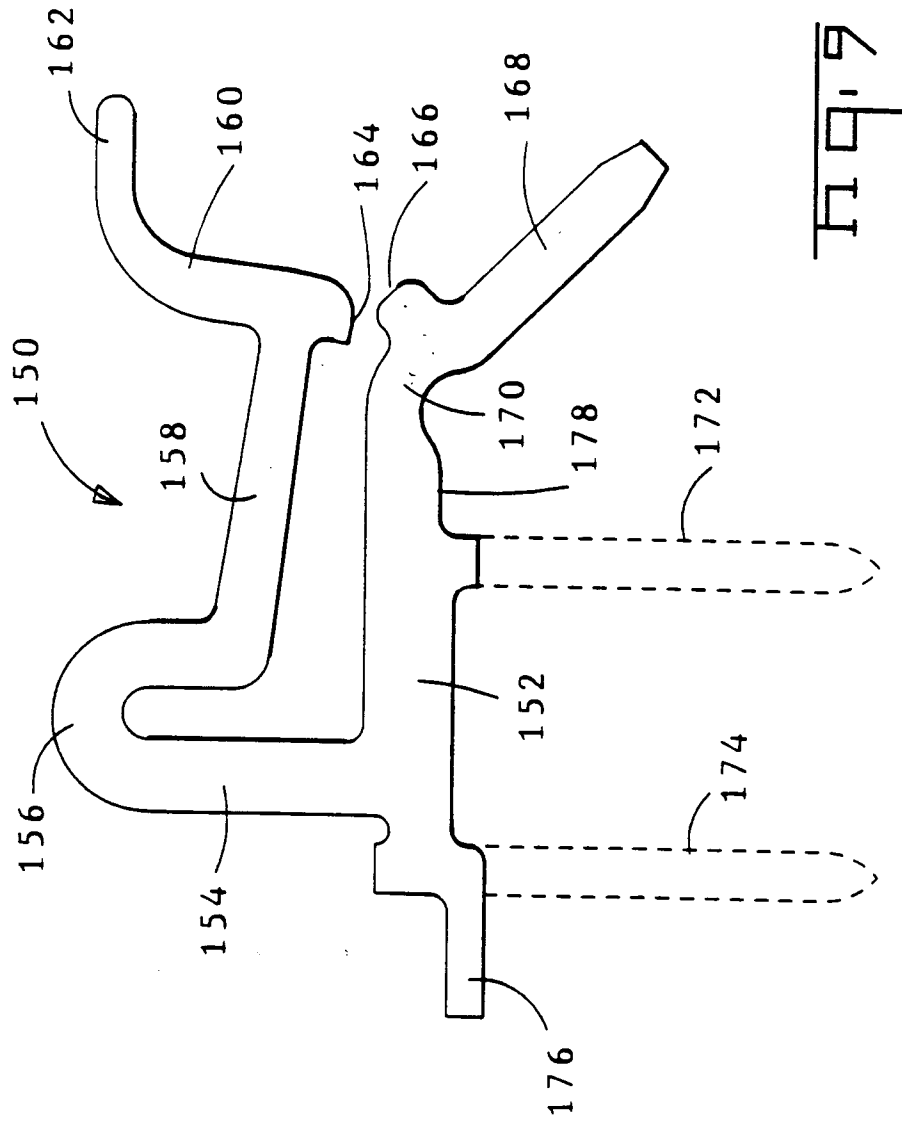

Fig. 9

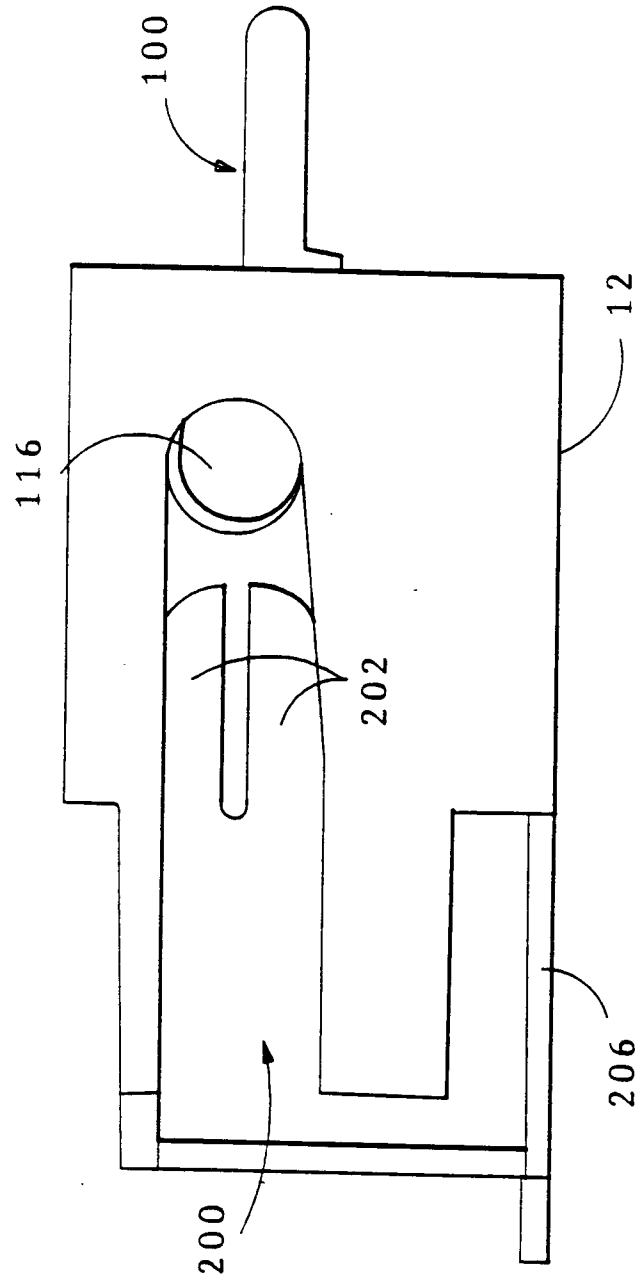

Fig. 10



