

No. 665,921.

Patented Jan. 15, 1901.

C. A. MILLER.
COMBINED CIGAR LIGHTING AND CLIPPING DEVICE.

(Application filed Aug. 31, 1900.)

(No Model.)

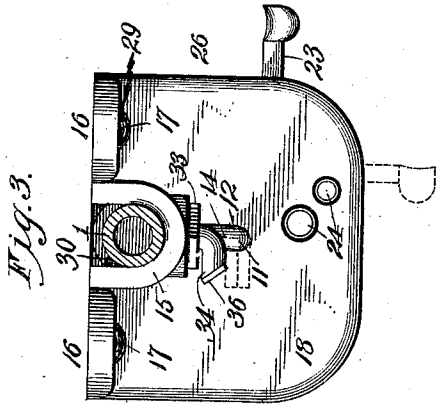

Fig. 3.

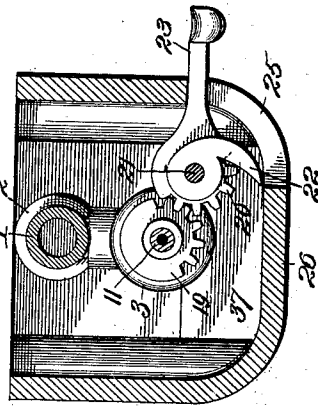

Fig. 4.

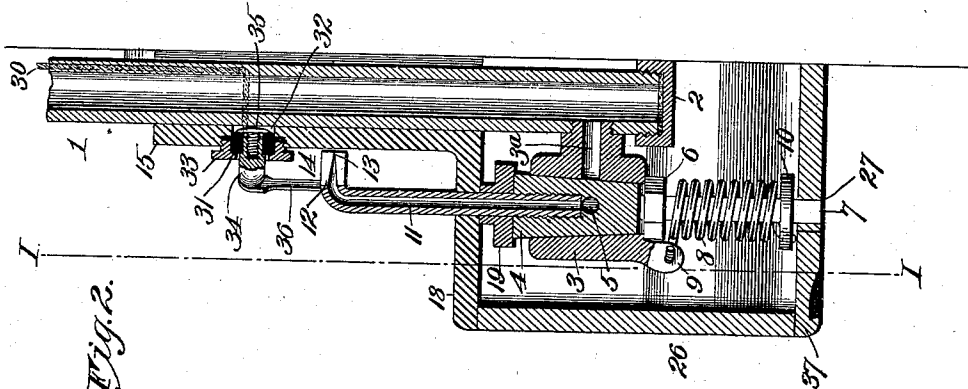

Fig. 2.

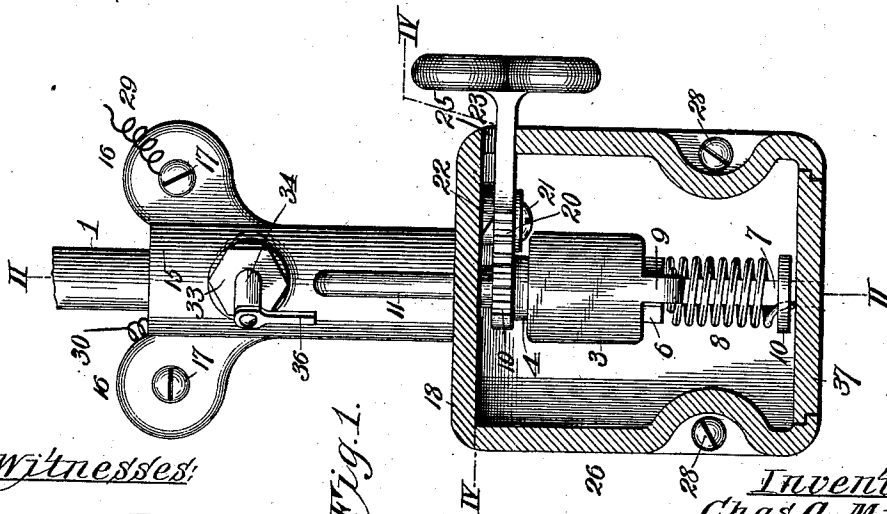

Fig. 1.

Witnesses:

H. C. Rodgers.
James T. Marlow

Inventor
Chas. A. Miller.

By Fischer & Hoop, Attys.

UNITED STATES PATENT OFFICE.

CHARLES A. MILLER, OF KANSAS CITY, MISSOURI.

COMBINED CIGAR LIGHTING AND CLIPPING DEVICE.

SPECIFICATION forming part of Letters Patent No. 665,921, dated January 15, 1901.

Application filed August 31, 1900. Serial No. 28,643. (No model.)

To all whom it may concern:

Be it known that I, CHARLES A. MILLER, a citizen of the United States, residing at Kansas City, Jackson county, Missouri, have invented a new and useful Combined Cigar Clipping and Lighting Device, of which the following is a specification.

My invention relates to a combined cigar clipping and lighting device, and more especially to that class of said devices by which a cigar can be clipped and gas ignited easily and quickly and which automatically restores the clipping mechanism to its original position and incidentally extinguishes the flame; and my object is to produce a device which is of ornamental appearance and of simple, strong, and durable construction.

To these ends the invention consists in certain novel and peculiar features of construction and combinations of parts, as hereinafter described and claimed; and in order that it may be fully understood reference is to be had to the accompanying drawings, in which—

Figure 1 is a vertical section taken on the line I I of Fig. 2. Fig. 2 is a vertical section taken on the line II II of Fig. 1. Fig. 3 is a top plan view of the device. Fig. 4 is a view taken on the line IV IV of Fig. 1.

In the drawings, 1 designates a gas-pipe arranged at a convenient point, closed at its front end by a cap 2 or equivalent means, and near said end it is provided with a gas-valve of the usual or any preferred construction, said gas-valve consisting of a T-coupling 3 and a conical rotatable plug 4, seated therein and provided with a passage 5, communicating at times with the passage 3^a in the T-coupling, which opens into the gas-pipe.

To compensate for wear on the valve, a tap 6, bearing against the bottom of the coupling, is mounted on a valve-stem 7, and to hold passage 5 of the plug normally out of engagement with the coupling-passage leading direct to the supply-pipe a spiral spring 8 is mounted on the valve-stem and is secured at its opposite ends to the lug 9, depending from the coupling, and the collar 10, secured rigidly on the stem.

The plug is provided with an upwardly-projecting stem 11 in axial alinement with stem 7 and communicating at its lower end with passage 5, the upper end of said tubular stem

11 terminating in a horizontal arm 12, having a fine jet-orifice 13 and preferably split for the greater part of its length, as shown at 14, 55 to admit of a certain leakage of gas to insure quick and reliable ignition at the proper time, as will be hereinafter referred to.

The upper part of the casement consists of the vertical half-sleeve 15, provided at its opposite sides with perforated ears 16, through which securing-screws 17 extend to clamp said section firmly over and upon the gas-pipe, as shown clearly, and formed at the lower end of said half-sleeve is a horizontal 65 plate 18, which constitutes the top of the box, hereinafter referred to. This plate or cover forms a journal for the tubular stem 11, and secured rigidly on said stem between said plate and the upper end of the plug is a mutilated gear-wheel 19, meshing with a similar gear-wheel 20, journaled upon a bolt 21, depending from said plate or cover, and formed integrally or otherwise secured to the upper side of said wheel 20 and working against the 75 lower face of the plate or cover is a knife 22, the same being adapted, as wheel 20 is turned through the medium of handle 23, to clip off the end of a cigar projecting down through one of the holes 24 of the plate or cover, in 80 the manner common to cigar-clipping machines. Said handle is adapted to operate through a space of about ninety degrees in a horizontal slot 25 in the upper end of the lower section or box 26 of the casement, said 85 box incasing all of the mechanism below the plate or cover 18 and having a journal-opening 27 in its lower end to constitute a bearing for the stem 7. The box is secured to the wall, wall-strip, or other object by means 90 of screws 28 or equivalent devices, which screws must be removed when it is desired to take the box down for any purpose. After the screws are removed the box is permitted to slip down off the lower end of stem 7 and 95 is then totally disconnected from the plate or cover and the operative parts of the device. It is as easily restored to position and is re-secured by replacing the screws 28.

From the foregoing it will be seen that by 100 grasping the handle 23 and throwing the same forward about ninety degrees the knife passes the holes 24, and the stem 11, hereinafter termed the "burner-tube," is thrown from

the position shown in full lines to the position shown in dotted lines, Fig. 3. By the time about half of said movement is effected gas begins to leak or escape from the arm or tip of the tube, because passage 5 at such time registers with the passage of the coupling leading to pipe 1, and in order to ignite such escaping gas I provide an electric igniter constructed by, preference, as follows:

29 designates an electric conductor electrically connected to one of the securing-screws of the upper part of the casement and to a source of electric supply. (Not shown.) 30 designates a similar conductor, which by preference extends down into the half-sleeve adjacent to pipe 1, being insulated from electric contact with said pipe and sleeve.

31 designates an insulating-collar clamped in an opening 32 in the half-sleeve above the burner-arm or tip of the burner-tube by a tap 33 and perforated to receive the reduced stem of the metallic arm 34, said arm being clamped against said insulating-collar by means of a screw-bolt 35, said screw-bolt also serving to clamp the naked end of the conductor 30 against the end of arm 34, so that the current must flow through conductor 30 and arm 34. The front end of said arm is bent laterally and carries a spring-contact 36, which lies in the path of movement of the arm or tip of the burner-tube 11, in order that as said tube is swung from the position shown in full to the position shown in dotted lines, Fig. 3, it shall make and break an electric circuit by scraping against the lower end of spring-contact 36 in such movement, a spark occurring as the circuit is broken, which instantly ignites the escaping gas, the same continuing to burn until the operator removes his hand from lever 23 and permits spring 8 to automatically return said lever to its original position and in such return incidentally throw the burner back to its original position and cut off the flow of gas from the supply-pipe to the burner-tube.

The accumulations of cigar-clippings are removed from the box by sliding forward the plate 37, step-jointed to and normally forming a part of the bottom of the box, this action providing an opening through which the clippings fall into a suitable receptacle placed to receive them.

From the above description it will be apparent that I have produced a device possessing the features of advantage enumerated as desirable, and while I have illustrated and described the preferred embodiment of the invention it is to be understood that it is susceptible of various changes as regards its form, proportion, detail construction, and arrangement of the parts without departing from the spirit and scope or sacrificing any of the advantages.

Having thus described the invention, what I claim as new, and desire to secure by Letters Patent, is—

1. In a device of the character described, the combination of a gas-supply pipe, a valve connected to the same, and a burner-tube connected to and operative with the valve, of a casement for the valve and gas-pipe, an arm secured to and insulated from the casement and provided with a spring-contact in the path of rotation of the burner-tube, electric conductors connected to the casement and to said insulated arm, an operating-lever geared to said valve, and a spring to automatically close the valve, substantially as described.

2. In a device of the character described, a gas-supply pipe, a valve for the same having a depending stem, a burner-tube projecting upwardly from the valve in axial alignment with said stem and terminating in a substantially horizontal burner arm or tip, a metallic casement consisting of an upper portion or cover in which said burner-tip is journaled, and a lower portion or box forming a journal for the depending valve-stem and provided with a slot, a spring encircling said depending valve-stem and arranged to automatically close the valve, a lever geared to the valve and projecting through said slot, an arm carried by but insulated from the casement and provided with a spring-contact in the path of the burner-tube arm or tip, an electric conductor connected to said insulated arm, and an electric conductor connected to the casement, substantially as described.

In testimony whereof I affix my signature in the presence of two witnesses.

CHARLES A. MILLER.

Witnesses:

H. C. RODGERS,
G. Y. THORPE.