

(19)



(11)

**EP 1 857 727 A3**

(12)

**EUROPEAN PATENT APPLICATION**

(88) Date of publication A3:  
**10.05.2017 Bulletin 2017/19**

(51) Int Cl.:  
**F17C 7/00 (2006.01)**

(43) Date of publication A2:  
**21.11.2007 Bulletin 2007/47**

(21) Application number: **07104176.8**

(22) Date of filing: **14.03.2007**

(84) Designated Contracting States:  
**AT BE BG CH CY CZ DE DK EE ES FI FR GB GR HU IE IS IT LI LT LU LV MC MT NL PL PT RO SE SI SK TR**  
Designated Extension States:  
**AL BA HR MK RS**

(72) Inventors:  
• **Lyu Sung Kak**  
**656-131, Geoje-si, Gyeongsangnam-do (KR)**  
• **Heo, An**  
**656-762, Geoje-si, Gyeongsangnam-do (KR)**  
• **Lee, Chul Woo**  
**656-132, Geoje-si, Gyeongsangnam-do (KR)**  
• **Park, Hyun Ki**  
**656-806, Geoje-si, Gyeongsangnam-do (KR)**

(30) Priority: **19.05.2006 KR 20060045018**

(71) Applicant: **DAEWOO SHIPBUILDING & MARINE ENGINEERING CO., LTD**  
**Seoul 100-180 (KR)**

(74) Representative: **Intès, Didier Gérard André et al**  
**Cabinet Beau de Loménie**  
**158 rue de l'Université**  
**75340 Paris Cedex 07 (FR)**

**(54) Method and apparatus for supplying natural gas to gas demand sides in LNG carrier**

(57) Disclosed herein is a method and apparatus for stable supply of natural gas (312) to a gas demand side (350) in an LNG carrier. With the method, natural gas comprising natural boil-off gas (313) generated in a cargo tank (310) containing LNG and forced boil-off gas generated by vaporizing LNG pumped from the cargo tank (310) is supplied to the gas demand side. The forced

boil-off gas or a mixed gas of the forced boil-off gas and natural boil-off gas having a predetermined pressure or more is returned to the cargo tank or to a gas header connecting a plurality of the cargo tanks to one another to supply the natural gas at the predetermined pressure or more.

Fig. 3

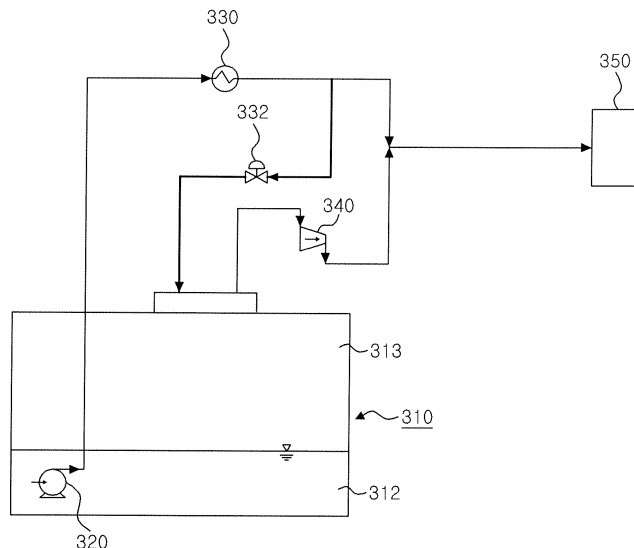

**EP 1 857 727 A3**



EUROPEAN SEARCH REPORT

Application Number  
EP 07 10 4176

5

10

15

20

25

30

35

40

45

50

55

DOCUMENTS CONSIDERED TO BE RELEVANT			
Category	Citation of document with indication, where appropriate, of relevant passages	Relevant to claim	CLASSIFICATION OF THE APPLICATION (IPC)
X	JP 2001 056096 A (ISHIKAWAJIMA HARIMA HEAVY IND) 27 February 2001 (2001-02-27) * fig.1, (1), (3), (9), (8), (23), (14), (21); [0010], [0022], [0023] *	1-9	INV. F17C7/00
A	US 2006/053806 A1 (TASSEL GARY W V [US]) 16 March 2006 (2006-03-16) * fig.1a, fig.2, (8), (34), (10), (13), (7), (31) *	1-9	
A	WO 2005/058684 A1 (WAERTSILAE FINLAND OY [FI]; MAHLANEN TIMO [FI]) 30 June 2005 (2005-06-30) * fig.1, (4), (3.1), (2.1), (7), (5), (3.9); abstract *	1-9	
			TECHNICAL FIELDS SEARCHED (IPC)
			F17C
The present search report has been drawn up for all claims			
Place of search <b>Munich</b>		Date of completion of the search <b>27 March 2017</b>	Examiner <b>Todor, H</b>
<p>CATEGORY OF CITED DOCUMENTS</p> <p>X : particularly relevant if taken alone                      Y : particularly relevant if combined with another document of the same category                      A : technological background                      O : non-written disclosure                      P : intermediate document</p> <p>T : theory or principle underlying the invention                      E : earlier patent document, but published on, or after the filing date                      D : document cited in the application                      L : document cited for other reasons                      &amp; : member of the same patent family, corresponding document</p>			

EPO FORM 1503 03 82 (P04C01)

ANNEX TO THE EUROPEAN SEARCH REPORT  
ON EUROPEAN PATENT APPLICATION NO.

EP 07 10 4176

5

This annex lists the patent family members relating to the patent documents cited in the above-mentioned European search report. The members are as contained in the European Patent Office EDP file on The European Patent Office is in no way liable for these particulars which are merely given for the purpose of information.

27-03-2017

10

15

20

25

30

35

40

45

50

55

Patent document cited in search report	Publication date	Patent family member(s)	Publication date
JP 2001056096 A	27-02-2001	NONE	
US 2006053806 A1	16-03-2006	CA 2580148 A1 US 2006053806 A1 WO 2006031634 A1	23-03-2006 16-03-2006 23-03-2006
WO 2005058684 A1	30-06-2005	AT 435150 T AT 506247 T CN 1898125 A CN 1898127 A EP 1694557 A1 EP 1694559 A1 FI 20031848 A JP 4597140 B2 JP 4778912 B2 JP 2007514597 A JP 2007516398 A KR 20060118549 A KR 20060125807 A PL 208380 B1 PL 212456 B1 US 2007051114 A1 US 2007175226 A1 WO 2005058684 A1 WO 2005058692 A1	15-07-2009 15-05-2011 17-01-2007 17-01-2007 30-08-2006 30-08-2006 13-01-2004 15-12-2010 21-09-2011 07-06-2007 21-06-2007 23-11-2006 06-12-2006 29-04-2011 31-10-2012 08-03-2007 02-08-2007 30-06-2005 30-06-2005