

[54] **LOW-PRESSURE INKING SYSTEM**
 [75] Inventors: **Abe Siegelman**, Morton Grove;
Robert N. Quoss, Clarendon Hills;
Raymond M. Pawlak, Addison, all
 of Ill.

3,705,043 12/1972 Zabiak..... 106/22 X
 R25,692 12/1964 Brown..... 346/107

FOREIGN PATENTS OR APPLICATIONS

1,064,663 9/1959 Germany..... 106/22

[73] Assignee: **Beckman Instruments, Inc.**,
 Fullerton, Calif.

Primary Examiner—Lorenzo B. Hayes
Attorney, Agent, or Firm—Mason, Kolehmainen,
 Rathburn & Wyss

[22] Filed: **June 16, 1972**

[21] Appl. No.: **263,699**

[57] **ABSTRACT**

Related U.S. Application Data

[63] Continuation of Ser. No. 50,652, June 29, 1970,
 abandoned.

A low-pressure inking system for oscillographic pen recorders is disclosed in which the pen is biased against the recording medium (paper) at low pressure so that special pen motors are unnecessary. The system includes a low-viscosity aqueous ink containing a glycol ether, a coloring agent and a soluble resin such as polyvinylpyrrolidone or polyethylene oxide. Low stylus tip pressure may be used so that the pen motor driving torque required to obtain good writing without hysteresis is substantially less than with conventional pressurized ink writing systems and retrofitting of conventional capillary recorders is made possible.

[52] U.S. Cl..... **346/140**; 106/22
 [51] Int. Cl.²..... **G01D 15/16**
 [58] Field of Search..... 106/22, 23; 346/140

References Cited

UNITED STATES PATENTS

2,176,777 10/1939 Tate..... 346/140
 2,771,372 11/1956 Chambers et al..... 106/22
 3,477,862 11/1969 Forsyth, Jr..... 106/22

2 Claims, 1 Drawing Figure

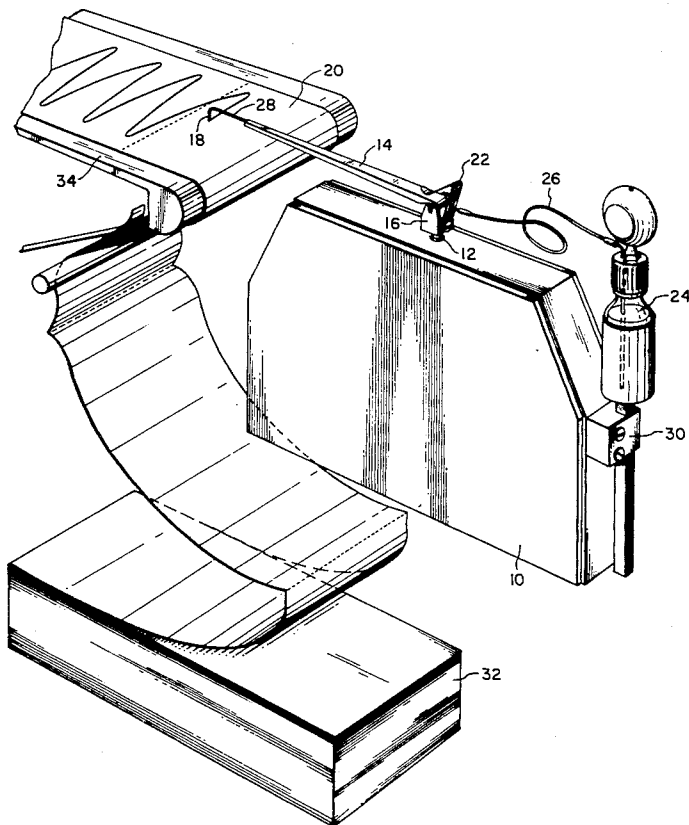

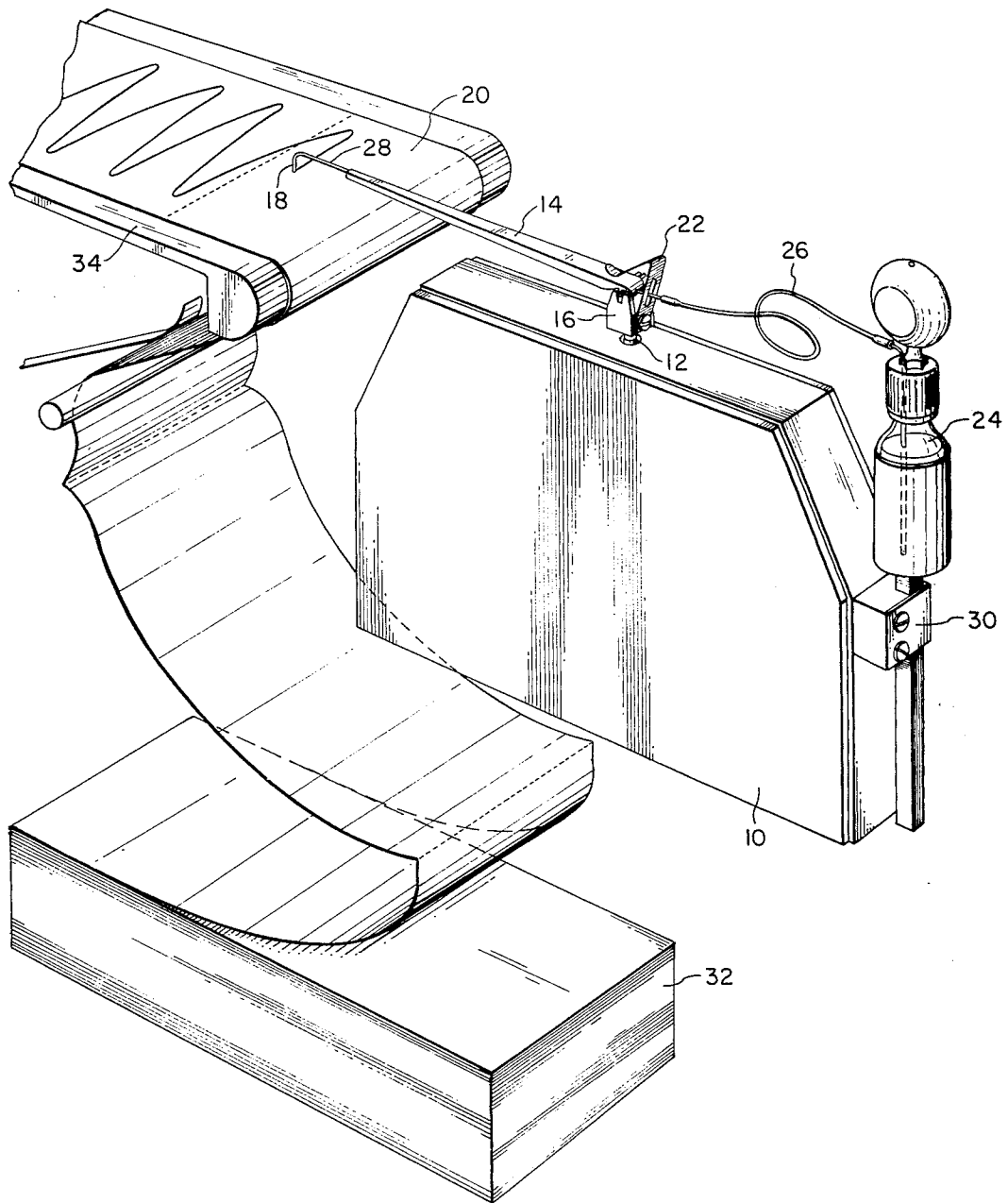

INVENTORS:

ABE SIEGELMAN

ROBERT N. QUOSS

RAYMOND M. PAWLAK

BY *Mason, Kolchman*
Rathburn & Wyss

LOW-PRESSURE INKING SYSTEM

This application is a continuation of applicants' co-pending application Ser. No. 50,652, filed June 29, 1970, now abandoned.

GENERAL DESCRIPTION OF INVENTION

This invention relates to an improved ink and hydrostatic inking system useful in oscillographic pen recorders and the like. In particular, it relates to a low-pressure hydrostatic inking system including a low-viscosity ink under a low hydrostatic head.

In the past the usual pen recorder of the oscillographic type used a liquid ink to write on a moving paper chart. This system had many advantages over electric writing and photographic systems in that it was relatively inexpensive and was instantaneous. However, it for years has suffered from many disadvantages. These disadvantages were sufficiently great that for many applications electric writing is used in spite of the high cost of the record medium; photographic devices are employed even though the film is expensive and has to be developed over a period of time; special ultraviolet recorders are used; and chemical recorders are used with heat; and straight heat recorders are used.

The chief disadvantages of the inking system as it was heretofore known have been due to the liquid ink which was used. This liquid ink had to dry quickly after it was applied to the moving record medium because otherwise it would smear as the paper was rolled up and the operator would often touch the wet ink causing loss of accuracy of the record, unsightly records, etc. The quick drying quality which was so highly desirable when the ink was applied to the chart paper was a tremendous disadvantage when the pen recorder was not used for a while, as it caused clogging of the small hole in the tip of the pen and consequently the pen often would not write when the instrument was first started. Systems were employed to force the ink out of the pen tip to clear the passageway so that the capillary forces involved in the pen and in the tube connecting the liquid ink supply to the pen would thereafter supply adequate ink for writing on the moving paper.

Another disadvantage inherent in the liquid ink system is that the rapidly oscillating pen tip would often throw drops of ink around the room.

A further disadvantage of prior systems is that certain of them (e.g., Brown Re. 25,692, Dec. 1, 1964) have required high-viscosity ink which had to be forced through the equipment under relatively high pressure. Such systems necessarily included pumps or pressurized gases which forced the ink through ducts to tubular pens. Generally the tubular pens were arranged so that the pen tips were held against record paper or similar material with substantial biasing force, and the ink under relatively high pressure was extruded against the record paper and sheared off as the pen tip moved relative to the latter. These systems have required special high-powered pen motors to move the pens which are biased against the record media.

The system of the present invention is an inking mechanism, having all the advantages of the previous liquid ink systems in that it is relatively inexpensive and is instantaneous, and in addition the new system obviates the disadvantages inherent in such liquid ink systems.

An object of the present invention is to provide a low-pressure hydrostatic inking system which does not require high viscosity ink, high pressure ink-supplying equipment, high biasing force on the pen tip or a special pen motor to activate the biased pen.

A further object of the invention is to provide low viscosity inks for use in such low-pressure hydrostatic inking systems.

Another object is to provide a low-viscosity ink which has adequate capillary strength suitable for use in low-pressure inking systems, which is rapidly absorbed by most types of paper, and which does not smear or "feather" on the paper.

Still another object is to provide a low-viscosity ink which is stable on storage at high and low pressures, does not bleed from pen tips, even when left in contact with paper for extended times.

A still further object is to provide a low-viscosity ink which does not splatter when the pen is moving rapidly or erratically.

These and other objects are apparent from and are achieved in accordance with the following disclosure, taken in connection with the attached drawing in which the single Figure illustrates a typical low-pressure inking system arrangement of the present invention.

Referring now to the drawing, the low-pressure, low viscosity inking system of the present invention is herein illustrated as comprising a pen motor, indicated generally at 10, which is arranged to be energized by any suitable electrical signal and provides rotation of the output shaft 12 thereof in proportion to the amplitude of said electrical input signal. A pen arm 14 is pivotally mounted on a carriage 16 secured to the upper end of the shaft 12 and is provided with a right angle pen tip portion 18 which is biased against the chart paper 20 by means of the spring clip member 22. Upon rotation of the shaft 12 the pen tip 18 is moved transversely of the paper 20 and ink stored in the chamber 24 is drawn out of this chamber through the tubing 26 and pen conduit 28 so that a fine, brilliant line is made on the paper 20 corresponding to the electrical input signal. Preferably, the tubing 26 is of polyethylene or butyl rubber and the conduit 28 is of stainless steel or inconel to avoid undesired interaction with and possible clogging of the ink described in detail hereinafter. The vertical position of the chamber 24 may be adjusted by means of a clamp member 30 to provide any desired gravimetric head but it is pointed out that the ink described hereinafter will function satisfactorily even under negative pressure, i.e., when the level of ink in the chamber 24 is below the pen tip 18.

In the illustrated embodiment the chart paper 20 is of the Z-fold type, a pack 32 of this type of paper being stored below the writing table 34 and being pulled tautly over the surface of this table by any suitable drive means. It is pointed out, however, that the chart paper may be of the roll type without folds. Also, in accordance with an important feature of the invention, the ink described hereinafter may be used with chart paper 20 of either the coated or uncoated type. When used with low-cost, uncoated paper the ink does not splatter and yet provides a high contrast, brilliant record trace which is comparable to that obtained with coated paper except for the high gloss of the paper itself. The inking system of the present invention is also particularly suited for use with coated paper of the Z-fold type because the low stylus pressure requirements

of the pen tip 18 and the particular characteristics of the ink described hereinafter accommodate the fold portions of this type of paper and the loose paper fibers which are usually present therein without clogging of the pen tip or interfering with the free flow of ink therefrom. A jewel pen tip 18 having a rounded bottom edge is preferably employed with this type of paper to let the pen slide over the paper folds easily. Furthermore, the fact that the spring clip 22 need exert only a slight biasing force on the pen tip 18 means that the torque requirements imposed on the pen motor 10 are relatively small, as compared to high-pressure, high-viscosity inking systems such as shown in Brown U.S. Pat. No. Re. 25,692, and hence conventional capillary ink systems with non-servo type galvanometers may be adapted to use coated, high gloss paper without requiring a change in the pen motor or driver electronics associated therewith.

In accordance with the present invention it has been discovered that low viscosity (i.e., 1-30 cps.) inks containing a major proportion of water and minor proportion of an alkylene glycol ether and a water-soluble resin are particularly desirable in low-pressure inking systems. Such inks do not spatter during operation of the equipment and effectively dry very rapidly, thus avoiding feathering and smearing, and can be used on coated recording paper, such as Kromekote paper, Trycite paper and similar high gloss paper, uncoated papers such as sulfite and sulfate papers, tissue paper, newsprint, tracing vellum, and films of polyamide. Moreover, such low viscosity inks can be fed to the pen tip under ordinary gravity pressure (0-8 inches), thus avoiding pumps and other pressurizing equipment called for by prior inking systems, and they can even be used at zero or negative pressure at lower writing rates by reason of their capillary strength. As a consequence, low stylus pressure (1-3 grams) is suitable to produce sharp recordings and high torque pen servomotors and position transducers are unnecessary.

The preferred viscosity of the ink is 5-10 cps. at 20°C. This ink can be supplied to the pen tip under pressures of less than ¼ psig. Pressures up to 2 psig. are satisfactory for all of the inks described herein.

The low viscosity ink contains a major proportion of water, and a water soluble dye is used in the ink of a type which will not greatly increase viscosity. The other essential components are a glycol ether which generally constitutes from about 10% to 40% of the weight of the ink, and a water-soluble resin such as polyvinylpyrrolidone or polyethylene oxide.

The glycol ether is an alkyl ether of ethylene or diethylene glycol, such as diethylene glycol mono-n-butyl ether, diethylene glycol monomethyl ether and diethylene glycol monoethyl ether, ethylene glycol monomethyl ether, ethylene glycol monoethyl ether, ethylene glycol mono-n-butyl ether and ethylene glycol monophenyl ether.

The ink contains sufficient water-soluble dye to produce a colored marking on paper or similar sheet material. Many such dyes are well known and can be selected on the basis of desired color, stability and compatibility with the other ink components.

A small percentage of a water-soluble resin such as polyvinylpyrrolidone (PVP) is used to prevent splattering at high speed pen travel. PVP is usually present in an amount from about 0.1% to 5% of the weight of the ink. It prevents breaking of the capillary in the pen tip,

reduces friction in the pen and tubing, keeps the ink cohesive, aids in holding the dye in solution, and prevents bleeding of the ink from the pen tip when the system is not in use. Polyethylene oxide serves the same purposes and can be substituted in smaller amounts for PVP. Usually the amount of polyethylene oxide is from about 0.01% to 0.3% of the weight of the ink. The preferred molecular weight range of this material is from about 500,000 to 5,000,000; with higher molecular weights less of the polyethylene oxide is required.

The aqueous, low viscosity ink is preferably neutral or slightly alkaline. Sometimes the dye and other components produce an alkaline solution, but in other situations it is often desirable to adjust the pH of the ink to 7 or slightly higher (e.g. 7.5 to 8) by adding traces of an organic amine such as ethanolamine. Other non-volatile, water-soluble amines can be used, such as diethanolamine, propanolamine and the like. However, slightly acidic inks with pH's between 6.5 and 7 are operative. Some inks which are slightly acidic (e.g., pH 6) are suitable but usually slightly alkaline inks are preferred.

It has been found in some cases that the addition of a small amount of phenol or similar agent reduces or prevents the growth of bacteria, mold and other microorganisms in the ink. These materials need be present only in low effective amounts (e.g. 0.01 to 0.5%). Usually they are not required because the glycol ether suppresses the growth of bacteria and mold.

The following examples illustrate formulations of suitable inks for the inking system of this application.

EXAMPLE 1

A low viscosity ink is produced from the following materials:

200 g. deionized water

100 g. diethylene glycol monobutyl ether

5 g. polyvinylpyrrolidone K-90 (PVP)

0.5 g. phenol

10 g. methyl violet dye (6B concentrate)

Sufficient ethanolamine to bring the pH to about 7.5.

The PVP is dissolved in the water with mixing, followed by the glycol ether and phenol. Mixing is continued and the dye is sifted into the vortex and completely dissolved. Then, ethanolamine (about 5 drops) is added dropwise with mixing until the pH is on the basic side (7.5 to 8).

The viscosity of the ink so produced is in the range from 10 to 15 cps. The ink is filled and stored in bottles.

This ink and the other aqueous glycol ether inks described herein are compatible with glycol-based inks such as the steam setting inks widely used in printing lines on oscillograph recording sheets and they form continuous lines over such inks.

EXAMPLE 2

Other suitable inks are produced by the procedure of Example 1 with the following formulations:

A.

100 g. deionized water

50 g. diethylene glycol monobutyl ether

2.5 g. polyvinylpyrrolidone K-90

8 g. acid red 6BC dye

Viscosity, 16.2 cps.; pH, 9.7.

5

B.

100 g. distilled water
 50 g. diethylene glycol monobutyl ether
 2.5 g. PVP K-90
 8 g. acid bright blue 2M dye
 5 drops ethanolamine
 Viscosity, 15 cps.; pH, 8.5.

C.

250 ml. distilled water
 25 ml. diethylene glycol monobutyl ether
 5 g. PVP K-90
 0.5 g. phenol
 10 g. methylviolet (6B) dye
 11 drops ethanolamine
 Viscosity, 15 cps., pH, 7.1.

D.

200 ml. deionized water
 100 ml. diethylene glycol monobutyl ether
 5 g. PVP K-90
 0.5 g. phenol
 10 g. methyl violet (6B) dye
 13 drops ethanolamine
 Viscosity, 16.8 cps.; pH, 6.85

E.

100 g. water
 50 g. diethylene glycol monobutyl ether
 2.5 g. PVP K-90
 5 g. acid green (4L extra concentrated) dye
 2 drops ethanolamine
 Viscosity, 14.3 cps.; pH, 9.3

F.

100 g. water
 50 g. diethylene glycol monobutyl ether
 2.5 g. PVP K-90
 8 g. acid green (4 LEX) dye
 Viscosity, 15 cps.; pH, 6.1

EXAMPLE 3

A low-viscosity ink suitable for both sulfite and romecote papers was made of the following materials:

150 g. water (deionized)
 50 g. ethylene glycol monomethyl ether
 6 g. Pontacyl violet S4B
 0.125 g. polyethylene oxide WSR-301 (approx. mol. wt. 4,000,000)

The polyethylene oxide was dissolved in the water, followed by the glycol ether and the dye. An intense violet ink, pH 8, viscosity 7 cps., was produced.

EXAMPLE 4

A green ink was produced by the procedure of Example 3 from the following:

150 g. water
 50 g. ethylene glycol monomethyl ether
 6 g. Keco acid green 4LEX
 0.125 g. polyethylene oxide WSR-301
 had pH 6.4 and viscosity 7 cps.

EXAMPLE 5

A red ink was produced by the procedure of Example 3 from the following:

450 g. water

6

150 g. ethylene glycol monomethyl ether
 18 g. Pontacyl carmine 2G
 0.375 g. polyethylene oxide WSR-301
 It had pH 9.7 and viscosity 6 cps.

5

EXAMPLE 6

A violet ink was produced from the following materials:

450 g. water
 10 150 g. ethylene glycol monomethyl ether
 0.375 g. polyethylene oxide WSR-301
 12 g. Crystal violet 6B conc.

It was adjusted to pH 7.9 with two drops of ethanolamine; viscosity 6.5 cps.

15

EXAMPLE 7

The following formula produces a suitable red ink:

150 g. water
 50 g. ethylene glycol monomethyl ether
 20 6 g. Keco acid red 6BC
 0.125 g. polyethylene oxide WDR-250 (approx. mol. wt. 600,000)

It had pH 9.7 and viscosity 7 cps.

The inks described in Examples 1 and 2 are particularly suited for use on coated paper. The slightly lower viscosity inks described in Examples 3 to 7, inclusive, write well on both coated and uncoated paper, and other materials, without splattering or bleeding and also exhibit slightly better non-clogging characteristics than the inks of Examples 1 and 2.

We claim:

1. A low-pressure hydrostatic writing system which comprises a record medium with an effectively absorbent surface, a pen having a tubular tip section biased against the surface of said record medium forming a closure therewith during writing operations, an ink having a viscosity in the range of about 1-30 cps within said pen, said ink comprising 20% to 35% by weight ethylene glycol monomethyl ether, a water-soluble coloring agent and a water-soluble resin selected from the group consisting of polyvinylpyrrolidone and polyethylene oxide, the amount of polyvinylpyrrolidone being 1.0% to 5% by weight and the amount of polyethylene oxide being 0.01% to 0.3% by weight, a hydrostatic head for applying a pressure of less than about 2 psig. to said ink during a writing operation sufficient to force said ink through the tip of said pen and against the surface of said record medium to cause said ink to be absorbed in the surface of said record medium, and means biasing said tubular pen against said record medium with a force of about 1-3 grams.

2. A low-pressure hydrostatic writing system which comprises a record medium with an effectively absorbent surface, a pen having a tubular tip section biased against the surface of said record medium forming a closure therewith during writing operations, an ink having a viscosity in the range of about 1-30 cps within said pen, said ink comprising a major proportion of water containing 10% to 40% by weight of a water-soluble ether of ethylene or diethylene glycol of the formula $R-(OCH_2CH_2)_n-OH$ wherein R is hydrocarbon radical containing one to six carbon atoms and n is an integer from one to two, inclusive, a water-soluble coloring agent and a water-soluble resin selected from the group consisting of polyvinylpyrrolidone and polyethylene oxide, the amount of polyvinylpyrrolidone

7

being 0.1% to 5% by weight and the amount of polyethylene oxide being 0.01% to 0.3% by weight, a hydrostatic head for applying a pressure of less than about 2 psig. to said ink during a writing operation sufficient to force said ink through the tip of said pen and against the surface of said record medium to

8

cause said ink to be absorbed in the surface of said record medium, and means biasing said tubular pen against said record medium with a force of about 1-3 grams.

5

* * * * *

10

15

20

25

30

35

40

45

50

55

60

65

UNITED STATES PATENT OFFICE
CERTIFICATE OF CORRECTION

Patent No. 3,906,513 Dated September 16, 1975

Inventor(s) Abe Siegelman, Robert N. Quoss and Raymond M. Pawlak

It is certified that error appears in the above-identified patent and that said Letters Patent are hereby corrected as shown below:

Column 6, line 43, "1.0%" should read -- 0.1% --.

Signed and Sealed this

twenty-third Day of December 1975

[SEAL]

Attest:

RUTH C. MASON
Attesting Officer

C. MARSHALL DANN
Commissioner of Patents and Trademarks

UNITED STATES PATENT OFFICE
CERTIFICATE OF CORRECTION

Patent No. 3,906,513 Dated September 16, 1975

Inventor(s) Abe Siegelman, Robert N. Quoss and Raymond M. Pawlak

It is certified that error appears in the above-identified patent and that said Letters Patent are hereby corrected as shown below:

Column 6, line 43, "1.0%" should read -- 0.1% --.

Signed and Sealed this

twenty-third Day of December 1975

[SEAL]

Attest:

RUTH C. MASON
Attesting Officer

C. MARSHALL DANN
Commissioner of Patents and Trademarks

UNITED STATES PATENT OFFICE
CERTIFICATE OF CORRECTION

Patent No. 3,906,513 Dated September 16, 1975

Inventor(s) Abe Siegelman, Robert N. Quoss and Raymond M. Pawlak

It is certified that error appears in the above-identified patent and that said Letters Patent are hereby corrected as shown below:

Column 6, line 43, "1.0%" should read -- 0.1% --.

Signed and Sealed this

twenty-third Day of December 1975

[SEAL]

Attest:

RUTH C. MASON
Attesting Officer

C. MARSHALL DANN
Commissioner of Patents and Trademarks