



(51) International Patent Classification:

H02K 1/16 (2006.01) *H02K 7/08* (2006.01)
H02K 16/00 (2006.01)

(21) International Application Number:

PCT/CA2017/050858

(22) International Filing Date:

14 July 2017 (14.07.2017)

(25) Filing Language:

English

(26) Publication Language:

English

(30) Priority Data:

62/363,202 15 July 2016 (15.07.2016) US
15/235,088 11 August 2016 (11.08.2016) US

(71) Applicant: **GENESIS ROBOTICS LLP** [CA/CA]; 20385
64 Avenue, Langley, British Columbia V2Y1N5 (CA).

(72) Inventors: **KLASSEN, James Brent**; #58 19505 68A Ave,
Surrey, British Columbia V4N6K3 (CA). **POPE, Bradley
Christopher**; 9402 207 Street, Langley, British Columbia
V1M2W7 (CA).

(74) Agent: **LAMBERT, Anthony R.**; 200, 10328 81 Avenue,
Edmonton, Alberta T6E 1X2 (CA).

(81) Designated States (*unless otherwise indicated, for every
kind of national protection available*): AE, AG, AL, AM,
AO, AT, AU, AZ, BA, BB, BG, BH, BN, BR, BW, BY, BZ,

CA, CH, CL, CN, CO, CR, CU, CZ, DE, DJ, DK, DM, DO,
DZ, EC, EE, EG, ES, FI, GB, GD, GE, GH, GM, GT, HN,
HR, HU, ID, IL, IN, IR, IS, JO, JP, KE, KG, KH, KN, KP,
KR, KW, KZ, LA, LC, LK, LR, LS, LU, LY, MA, MD, ME,
MG, MK, MN, MW, MX, MY, MZ, NA, NG, NI, NO, NZ,
OM, PA, PE, PG, PH, PL, PT, QA, RO, RS, RU, RW, SA,
SC, SD, SE, SG, SK, SL, SM, ST, SV, SY, TH, TJ, TM, TN,
TR, TT, TZ, UA, UG, US, UZ, VC, VN, ZA, ZM, ZW.

(84) Designated States (*unless otherwise indicated, for every
kind of regional protection available*): ARIPO (BW, GH,
GM, KE, LR, LS, MW, MZ, NA, RW, SD, SL, ST, SZ, TZ,
UG, ZM, ZW), Eurasian (AM, AZ, BY, KG, KZ, RU, TJ,
TM), European (AL, AT, BE, BG, CH, CY, CZ, DE, DK,
EE, ES, FI, FR, GB, GR, HR, HU, IE, IS, IT, LT, LU, LV,
MC, MK, MT, NL, NO, PL, PT, RO, RS, SE, SI, SK, SM,
TR), OAPI (BF, BJ, CF, CG, CI, CM, GA, GN, GQ, GW,
KM, ML, MR, NE, SN, TD, TG).

Published:

— with international search report (Art. 21(3))

(54) Title: ROTARY ACTUATOR

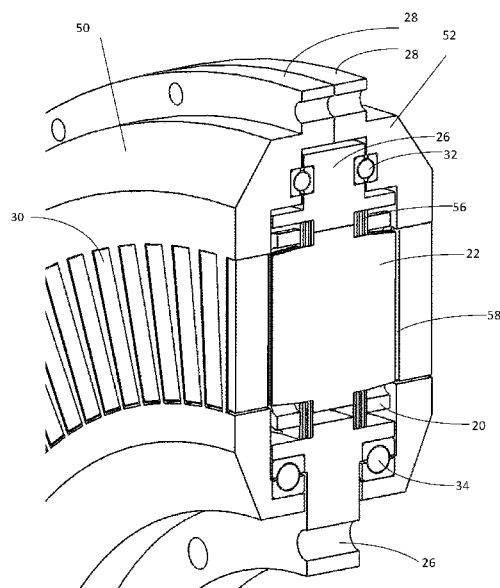

Fig. 1

(57) Abstract: An actuator for high rotational speed applications using a stator which utilizes laminated features to reduce Eddy current losses in the stator. This construction allows high pole counts while providing the efficiency and high speed benefits of a laminated construction. Laminated construction is very challenging for a high pole count lightweight motor, but embodiments of the device provide structural strength, and rigidity, as well as other benefits such as low manufacturing cost, high heat dissipation, integrated cooling channels, and light weight construction. Many of these benefits result from the use of a laminate sandwich of non-magnetic, heat conductive material, such as anodized aluminum, as a structural member of the stator.



ROTARY ACTUATOR

TECHNICAL FIELD

[0001] Actuators.

BACKGROUND

[0002] A high pole count motor has many advantages such as the potential for high torque and light weight. It has been shown in WIPO published patent application WO2017024409A1 that a solid stator can provide adequate performance in regard to minimizing eddy currents when speeds are relatively low such as when used in robotics. For higher speed applications the use of laminates is preferable to reduce eddy current losses. The challenge is that a high pole count axial motor has a very thin profile (if it is to take advantage of the torque to weight potential) and is therefore very difficult to build out of laminates. For example, if a single rotor and single stator construction is used, the forces pulling the stator and rotor together across the airgap would be expected to shear the glue-lines holding the laminated structure together such that the airgap would not be maintained.

SUMMARY

[0003] A rotary actuator solves this problem in a number of ways that include using a double rotor configuration where the stator is positioned between the two rotors. An advantage of this configuration is that the magnetic forces on the stator are reasonably equal in both axial directions on each of the posts at all times. This reduces the load on each of the posts and reduces the stress on each of the glue lines in the stator assembly. The tangential forces on each of the posts can also be very high when under full power, but these forces are also balanced on each posts such that the glue lines are not highly stressed at any time.

[0004] Therefore, in an embodiment, there is disclosed an electric machine comprising a stator disposed between rotors, the rotors being mounted on bearings for rotation relative to the stator about an axis of the electric machine, the rotors being separated from the stator by respective air gaps; the stator being formed of structural members, each structural member being formed of laminates, each laminate having a smallest dimension that extends axially; each

structural member having slots, and magnetic posts fixed within the slots for support of the magnetic posts by the structural member; and one or more electrical conductors disposed about the posts for generating a series of commutated electromagnetic poles.

BRIEF DESCRIPTION OF FIGURES

[0005] Embodiments of a rotary actuator will now be described by way of example, with reference to the figures, in which like reference characters denote like elements, and in which:

[0006] Fig 1. is a section view of an embodiment of a high speed actuator showing the rotor with magnets, thrust bearings, four-point contact bearings, a stator with laminated posts, laminated structural member of the stator, the solid structural member and the conductors.

[0007] Fig 2. is a view of an exemplary embodiment having laminated posts installed between the laminated structural member.

[0008] Fig 3. is a view of the laminated structural member of the stator showing a preferred stack layup of laminations. Where the radial cut is radially inward or outward of the stator post slot, and alternates for each adjacent layer.

[0009] Fig. 4 is a view showing the installation of the laminated stator posts into the laminated structural member of the stator with no solid structural member present.

[0010] Fig. 5 is a view showing the installation of the laminated stator posts into the laminated structural member of the stator with a solid structural member present which has mounting features.

[0011] Fig. 6 shows how the Eddy current path is broken by the radial cuts made; both inward and outward of the stator post slot, in the laminates of the laminated structural member.

[0012] Fig. 7 is a section view of the stator and rotor to show the orientation of the magnets in the rotor and the flux path across the laminated stator posts.

[0013] Fig. 8 is a view of the final lamination assembly with 2 laminated structural pieces and laminated stator posts.

[0014] Fig. 9 is a cutaway view of the stator with some posts and coils removed.

DETAILED DESCRIPTION

[0015] A rotary actuator is disclosed that uses a double rotor configuration where the stator is positioned between the two rotors. An advantage of this configuration is that the

magnetic forces on the stator are reasonably equal in both axial directions on each of the posts at all times. This reduces the load on each of the posts and reduces the stress on each of the glue lines in the stator assembly. The tangential forces on each of the posts can also be very high when under full power, but these forces are also balanced on each posts such that the glue lines are not highly stressed at any time.

[0016] It is desirable to use a “backiron” in this configuration (which does not actually become part of the flux path as with a conventional single stator) with high structural strength and rigidity, as well as high thermal conductivity. Aluminum would be an excellent choice in terms of high strength to weight and high thermal conductivity, but aluminum also has high electrical conductivity so it would generate high eddy currents especially at high operating speeds.

[0017] To take advantage of the structural and thermal benefits of aluminum for the backiron, a rotary actuator is disclosed that uses a stack of two or more aluminum disks with slots in the disks to receive the posts, and additional slots, such as radially outward or inward from the slots, to eliminate an electrically conductive path around each of the posts. A single piece of aluminum may be used with radial slots to prevent eddy currents, but it is believed by the inventors that a laminated aluminum structure with eddy current slots that alternate from layer to layer from radially inward to radially outward, provide a stronger and stiffer structure for a given thickness. This is because the eddy current slots on one layer align with a non-slotted ring of material on the next aluminum layer such that the no two adjacent layers have aligned eddy current slots.

[0018] The aluminum in the backiron laminates may be coated but they are preferably anodized such as with a hard anodized finish. Anodizing is essentially a ceramic coating which provides high dielectric strength and reasonably good thermal conductivity.

[0019] An electric motor/actuator may comprise of a stator which utilizes ferromagnetic material laminates for the electromagnetic posts to reduce the Eddy Current losses. And a high thermal conducting material is preferred to be used in the stator structure to get heat out of the device. The rotor may be made of a ferrous material that performs as required.

[0020]	ID Ref. #	Description
[0021]	20	Stator Coil
[0022]	22	Stator Post Laminate

[0023]	24	Stator Non-Ferrous Structural Laminate
[0024]	26	Stator back Bone
[0025]	28	Outer Rotor Housing
[0026]	30	Rotor Magnet
[0027]	32	Thrust Bearing
[0028]	34	Ball Bearing
[0029]	36	Stator Post Laminated Assembly
[0030]	38	"M" Non-Ferrous Stator Structural Laminate
[0031]	40	"W" Non-Ferrous Stator Structural Laminate
[0032]	42	Discontinuous Eddy Current Loop Path
[0033]	44	Internal Stator Cooling Chamber
[0034]	46	Radial Cut
[0035]	48	Stator Post and structural laminate
[0036]	50	Rotor Side 1
[0037]	52	Rotor Side 2
[0038]	54	Rotor pole
[0039]	56	Structural laminate Assembly
[0040]	58	Air gap
[0041]	60	Slots
[0042]	62	Ridges on the stator backbone
[0043]	64	Channel around inside of stator structural members
[0044]	66	Chambers between the structural members and between the posts
[0045]		As shown in Fig. 1, an electric machine comprises a stator, with a backbone 26 and structural laminate assembly 56 disposed between rotors 50 and 52, the rotors 50, 52 being mounted on bearings 32, 34 for rotation relative to the stator about an axis of the electric machine. Approximate location of the axis is identified as A in Fig. 4. The rotors 50, 52 are separated from the stator by respective air gaps 58. As shown in Fig. 2, the stator structural laminate assembly 56 may comprise structural members 24, each structural member being formed as shown in Fig. 2 of annular laminates 38, 40 each laminate 38, 40 having a smallest dimension that extends axially. Each structural member 24 and the corresponding laminates have openings or slots 60, and (as shown in Fig. 4) magnetic posts 36 fixed within the slots 60

for support of the magnetic posts by the structural member 24. The slots 60 may have a longest dimension that extends radially, an intermediate dimension that extends circumferentially and a depth that extends axially. As shown in Fig. 2, one or more electrical conductors 20 are disposed about the posts 36 for generating a series of commutated electromagnetic poles. There may be M poles and N posts and the greatest common factor of N and M is three or more.

[0046] As shown in Fig. 5, the backbone 26 comprises an outer backbone 68 and inner backbone 70, with the structural members 24 being secured on either side of ridges 62 that extend respectively inward of the outer backbone and outward of the inner backbone. The structural members 24 may be secured to the ridges 62 by any suitable means such as glue.

[0047] The rotors 50, 52 are mirror images of each other and are secured to each other for example with bolts or screws (not shown) at their outside peripheries. As shown in Fig. 1 the rotors 50, 52 are mounted for rotation relative to the stator on radial bearings 34 at the inside of the stator and on thrust or axial bearings 32 at the outside of the stator. Bearing races are formed on the backbone 26 of the stator and in the rotors 50, 52. The stator backbone 26 may be secured to a fixed structure at the inner periphery of the backbone 26 by any suitable means. The outward periphery 28 of the rotors 50, 52 may then be used as the output. Power for the windings 20 may be supplied through the inner part of the backbone 26 through channels (not shown). As shown in Fig. 2 the radial length of the stator posts 22 between the structural members 24 may be less than the distance between the ridges 62 of the stator backbone 26 to form a channel 64 around the stator that may be used for flow of a cooling fluid. Channels (not shown) in the inner part of the stator backbone 26 may be used for flowing a cooling fluid in and out of the channel 64.

[0048] An exemplary embodiment may use an Iron alloy for the stator posts laminations and an Aluminium alloy for the structural laminates. The stator of an electric machine is formed of structural laminates 24 that have slots that posts 22 are fixed within. The structural laminates 24 have a thinnest dimension in the axial direction, and in the radial direction are annular.

[0049] For the structural laminate 24, as shown in Fig. 3, it is preferred to have radial cuts 46 made from the post slot to the edge of the material to remove the Eddy current loop path 42 around the stator post, as shown in Fig. 6. Slots may also be between the posts such as circumferentially between every second post. The preferred embodiments have opposing radial cuts per layer, as seen in Fig. 3, these may be referred to as the "M" 38 and "W" 40 laminates.

This is to remove the Eddy current loop path 42 on all the layers of the structural laminate while still maintaining adequate strength and rigidity in the aluminum layers by virtue of the overlapping sections on one or both sides of each slot on another layer. In an embodiment shown in Fig. 2, it is shown to have but not limited to five layers in each laminated assembly 24, the quantity of the layers is driven by the design scope. This then creates a thicker assembly that has the strength requirement and will reduce the loss from the Eddy Currents by virtue of the interrupted eddy current path on each layer, and the electrical insulation, such as an anodized surface, between each layer.

[0050] The stator post laminates 36, which are preferred to be mounted perpendicular to the structural laminate 24, are then to be mounted between two structural laminates to create the stator, this can be seen in Fig. 4 where an embodiment is mechanically fixed between the structural laminates by a tab at the inner and outer radial position. This assembly may be preferred to have interference and be pressed together to create a solid assembly 48 as seen in Fig. 8. It may be preferred to then coat this sub-assembly in a potting compound to add another material to help the heat get from the stator posts to the structural laminate. The magnetic posts may have an enlarged central section that defines respective shoulders that form the tabs and the respective shoulders engage the structural members to resist axial movement of the magnetic posts within the structural members. The posts and structural members together define chambers 66.

[0051] In this preferred configuration a post lamination 36 is used for two stator posts, and acts as a single magnetic dipole. This requires the rotor to have the magnets 30 on side 52 to form poles 54 rotated by one pitch relative to side 50. So that a North Pole is across from a South Pole on the other side of the rotor, seen in Fig. 7 so that axially opposed magnets have opposite polarity.

[0052] The chambers 66 and channel 64 together create a chamber 44 between the two structural laminates as seen in Fig. 2 and Fig. 9, which may extend throughout the space between the stator backbone and rotors that is not occupied by the structural members 24 or the posts. This chamber may be filled with a fluid or gas to remove heat from the stator and stator coils. This is preferred as the fluid or gas will be in direct contact with the center of stator post and structural laminated member which will allow effective heat transfer. This may be preferable as this allows the device to run at higher currents while maintaining a stable, desired temperature.

The fluid or gas in this chamber is preferred to flow through the chamber due to a pressure differential between an inlet and an outlet (not shown, but may be in the inner backbone). The fluid or gas may also remain static, or if air cooling is preferred, ambient air may also flow through by natural convection.

[0053] To manufacture the device, it may be necessary or helpful to insert a spacer between the two laminated structural members when the posts and aluminum disks are assembled. Then after the coils are added and the stator is potted, the spacer prevents the potting compound from filling the space between the laminated aluminum disks. This spacer is preferably made of a dissolvable material or a meltable material such as wax, which can be removed by dissolving or melting after potting is complete.

[0054] To attach the laminated stator assembly to another entity it may be required to insert a solid member in-between the laminates during the assembly process. This is shown in Fig. 5 where an exemplary member is inserted between the structural laminations. This exemplary member allows bearing on the ID and OD to be used and a bolt hole pattern on the ID flange 72 of stator backbone 26.

[0055] A single set of coils could be used between the two structural members with shorter posts, instead of the coils 20 shown, that only just protrude from the structural members. This would not have the cooling benefits but would be a lower profile assembly.

[0056] With a rotor on each side of the stator, there are balanced axial forces on the stator poles that results from the rotor poles acting with equal force on both axial ends of each post. This tends to eliminate the shear force on the stator post laminates, which reduces the strain on the glue layers between the laminates. The mechanical securing of the stator post laminates between the two aluminum layered disks (with the wider section of the posts between the aluminum layered disks) resists movement of the laminates even if the glue fails. The design reduces eddy currents in the laminates of the structural members as a result of the alternating ID - OD slots in each layer. Alternating from ID to OD with each successive layer provides a non-interrupted surface on at least one side of each eddy current prevention slot on an adjacent layer.

[0057] The use of aluminum for the structural members results in a lighter weight structure with excellent heat dissipation characteristics. Anodizing these layers before assembly provides electrical insulation with minimal thermal insulation between layers. The space between the aluminum layered disks can also be used for internal fluid cooling.

Claims

1. An electric machine comprising
a stator disposed between rotors, the rotors being mounted on bearings for rotation relative to the stator about an axis of the electric machine, the rotors being separated from the stator by respective air gaps;
the stator comprising structural members, each structural member being formed of laminates, each laminate having a smallest dimension that extends axially;
each structural member having slots, and magnetic posts fixed within the slots for support of the magnetic posts by the structural member; and
one or more electrical conductors disposed about the posts for generating a series of commutated electromagnetic poles.
2. The electric machine of claim 1 in which there are M poles and N posts and the greatest common factor of N and M is three or more.
3. The electric machine of claim 1 or 2 in which each post includes an eddy current reduction feature comprising electrical insulating laminates or powder.
4. The electric machine of claim 1, 2 or 3 in which each laminate of the structural members includes a barrier to completion of an electrical current circuit around the posts.
5. The electric machine of claim 4 in which each barrier comprises a slot in the corresponding laminate.
6. The electric machine of claim 5 in which the slots in adjacent laminates are located on opposed sides of the posts.
7. The electric machine of any one of claims 1-6 in which the posts comprise laminated ferrous material.

8. The electric machine of any one of claims 1-7 in which the posts comprise electrically insulated powdered material.
9. The electric machine of any one of claims 1-8 further comprising a stator backbone to which the structural members are mounted.
10. The electric machine of claim 9 in which the structural members are spaced apart by ridges on the stator backbone.
11. The electric machine of claim 9 or 10 in which the stator backbone comprises an inner part and an outer part.
12. The electric machine of claim 11 in which the bearings comprise radial bearings between the rotors and inner part of the backbone and axial thrust bearings between the rotors and the outer part of the backbone.
13. The electric machine of claim 10, 11 or 12 in which the structural members form chambers between the structural members and the posts, and a channel extends around the inner part of the backbone, the chambers and channel combining to form a cooling chamber within the stator.
14. The electric machine of claim 4 in which the barrier to electric currents comprises radial cuts in the respective laminates made from a post slot to an adjacent edge of the laminate.
15. The electric machine of claim 14 in which the radial cuts alternate on adjacent laminates between opposing sides of the slots.
16. The electric machine of claim 14 or 15 in which the cuts comprise blind slots.
17. The electric machine of any one of claim 1-16 in which the stator posts are laminated.

18. The electric machine of claim 17 in which the stator posts comprise magnetic materials.
19. The electric machine of any one of claims 1-18 in which the laminated posts extend axially outward on both sides of the structural members and pass through each of the structural members, each post forming a magnetic dipole, and axially opposed magnets of the rotors have opposite polarity.
20. The electric machine of any one of claims 1-19 in which the structural members comprise non-magnetic material.
21. The electric machine of claim 20 in which the laminates of the structural members comprise anodized aluminum.
22. The electric machine of any one of claims 1-21 in which the magnetic posts have an enlarged central section defining respective shoulders and the respective shoulders engage the structural members to resist axial movement of the magnetic posts within the structural members.

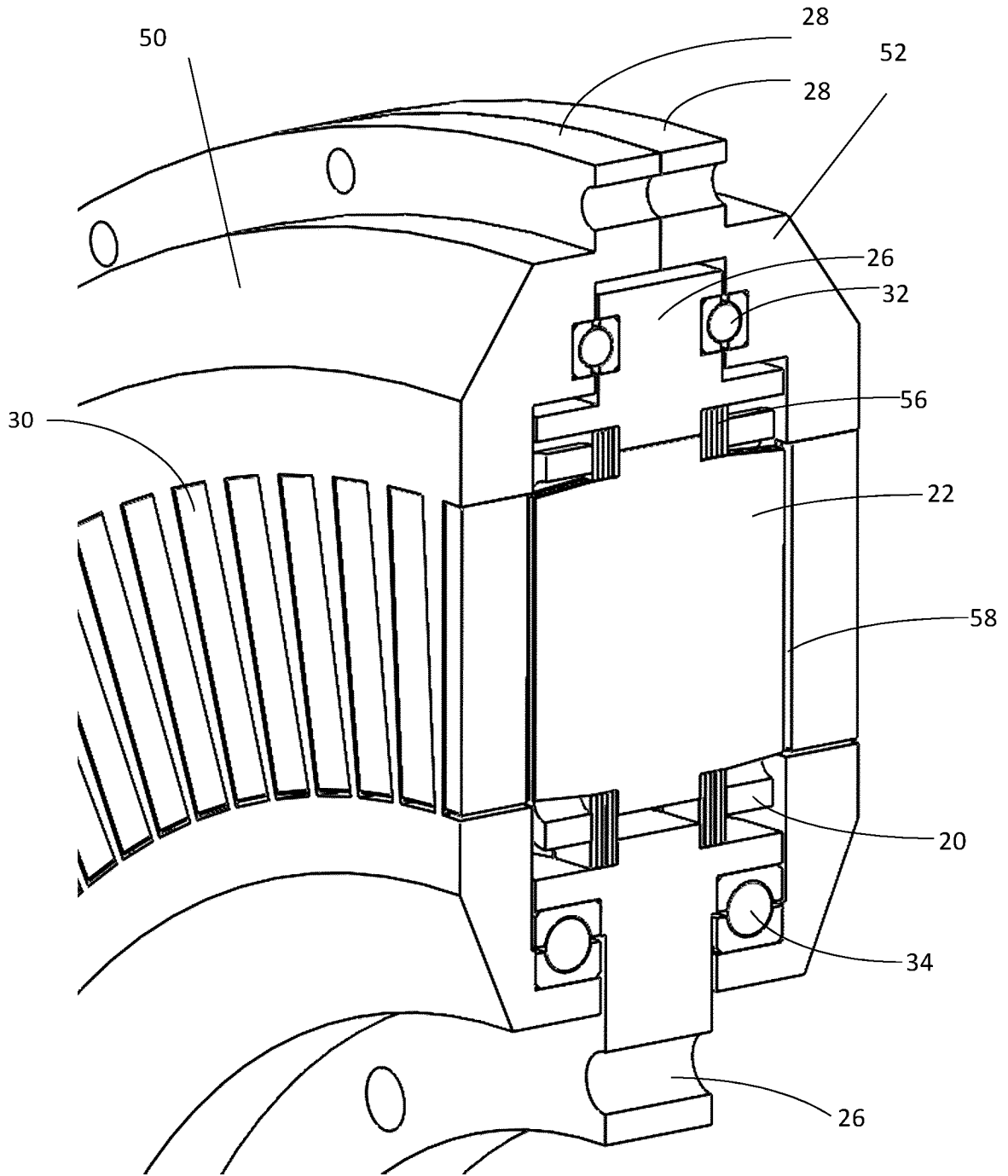

Fig. 1

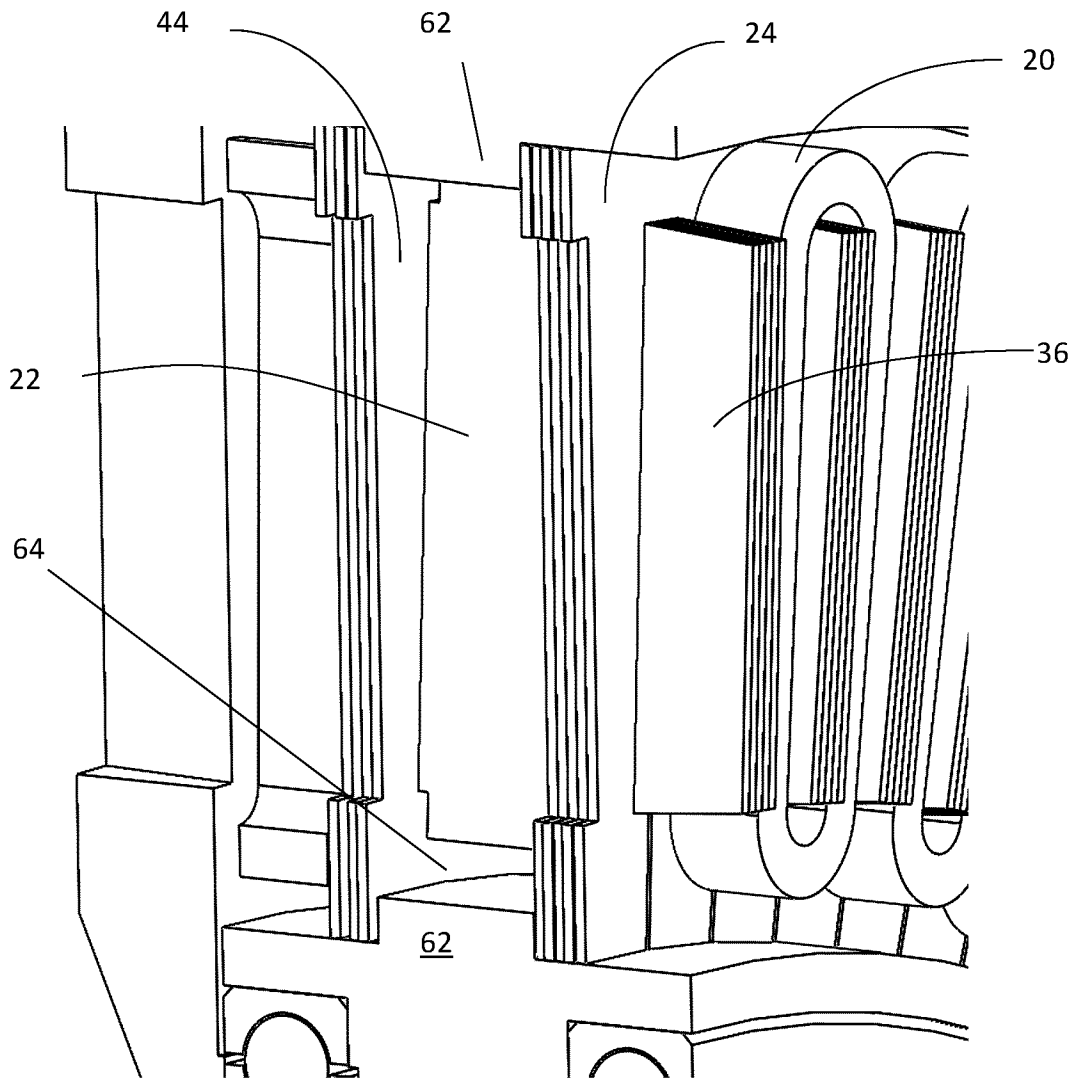

Fig. 2

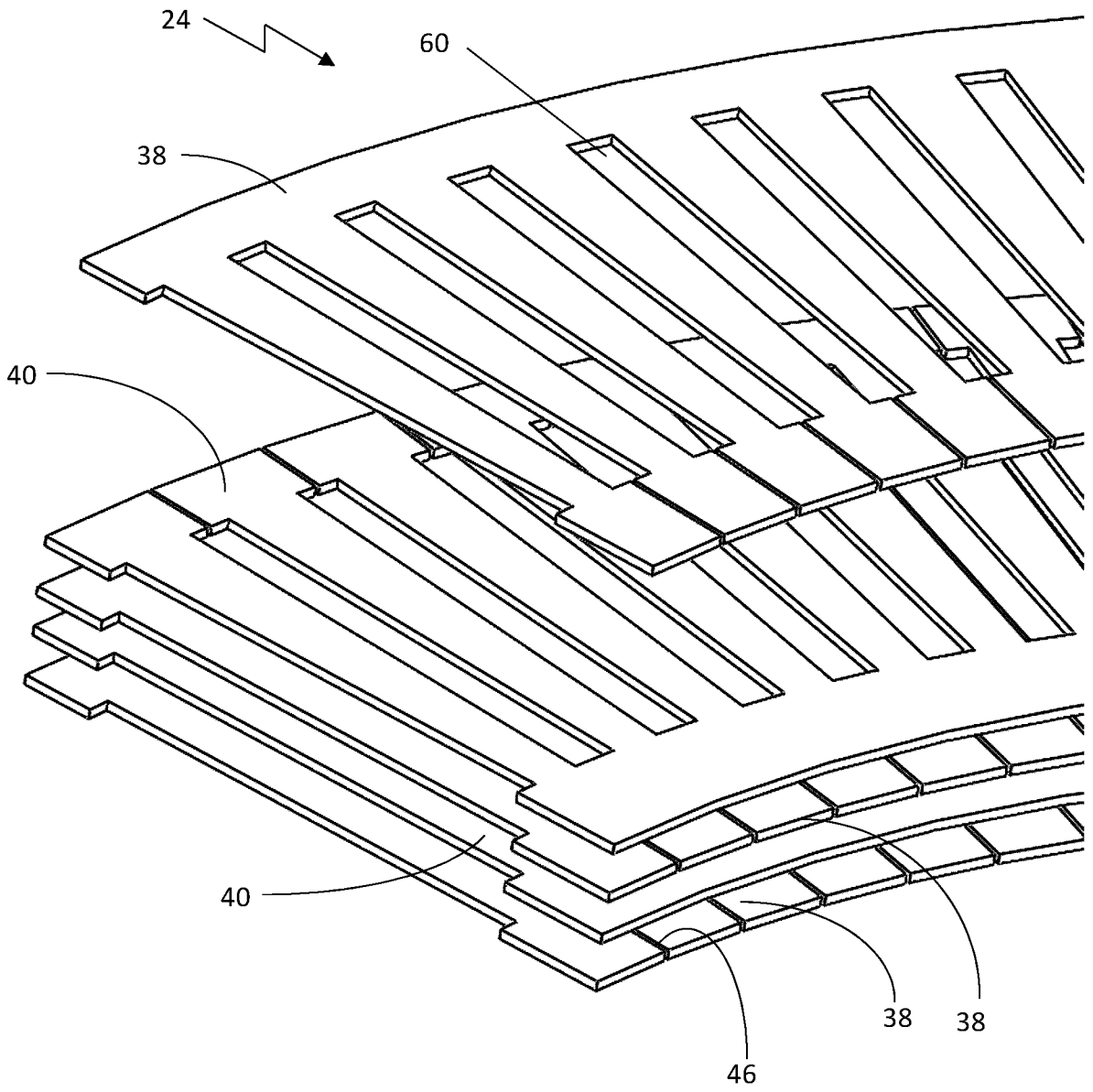

Fig. 3

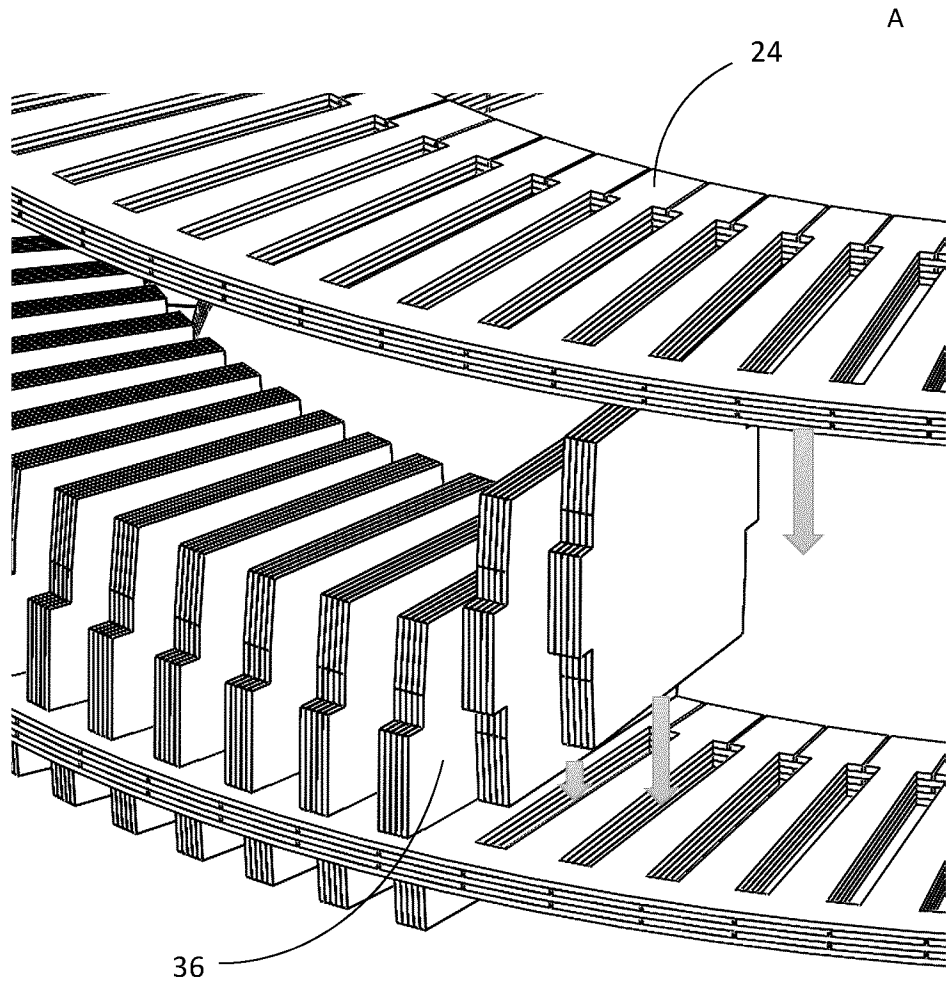

Fig. 4

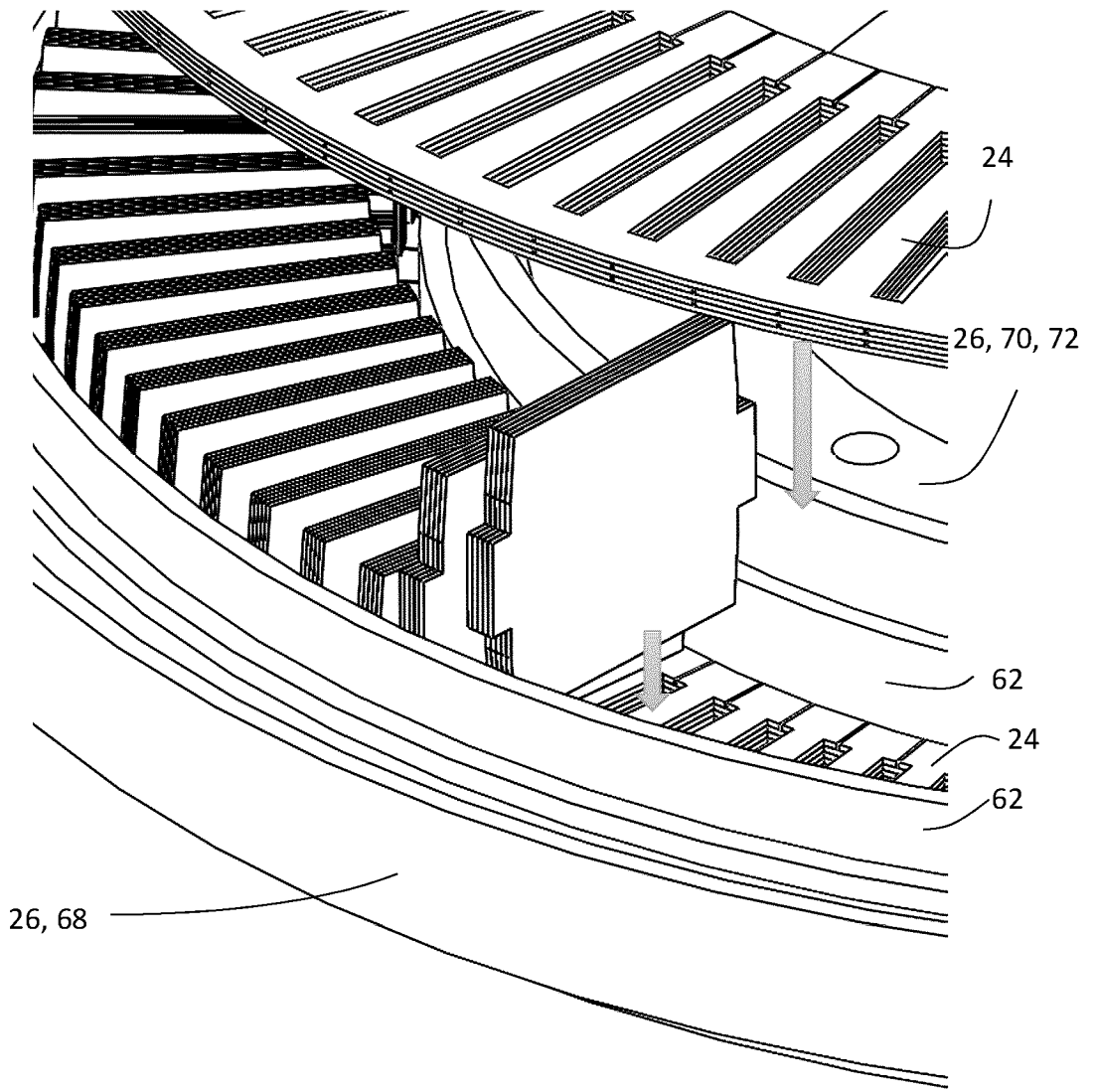

Fig. 5

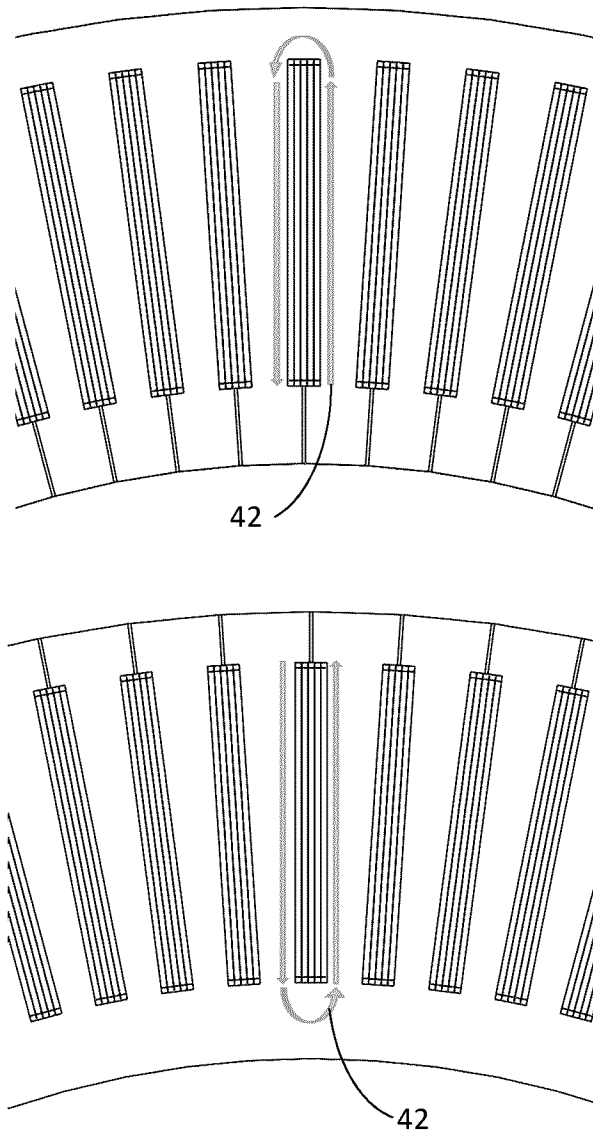

Fig. 6

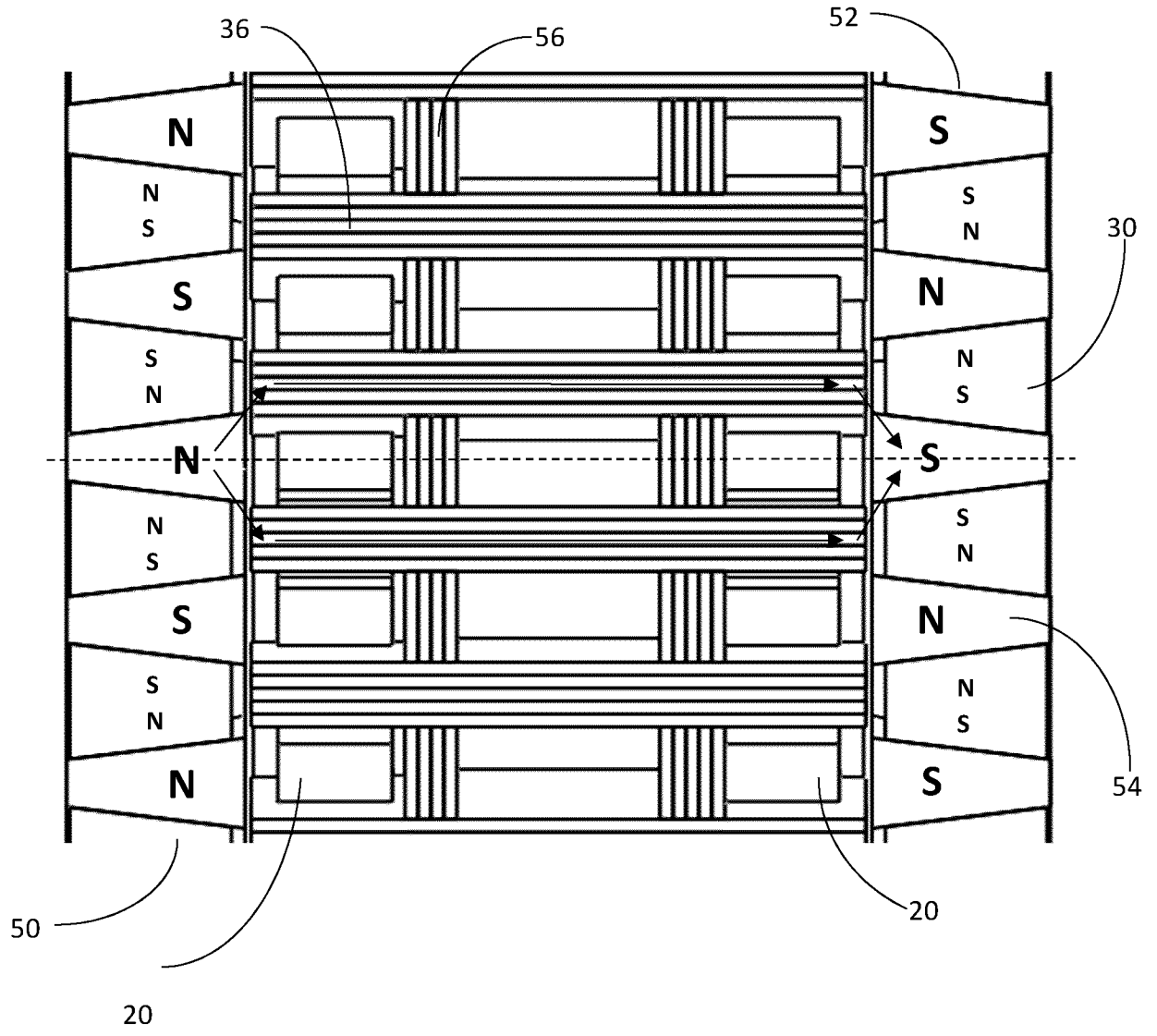

Fig. 7

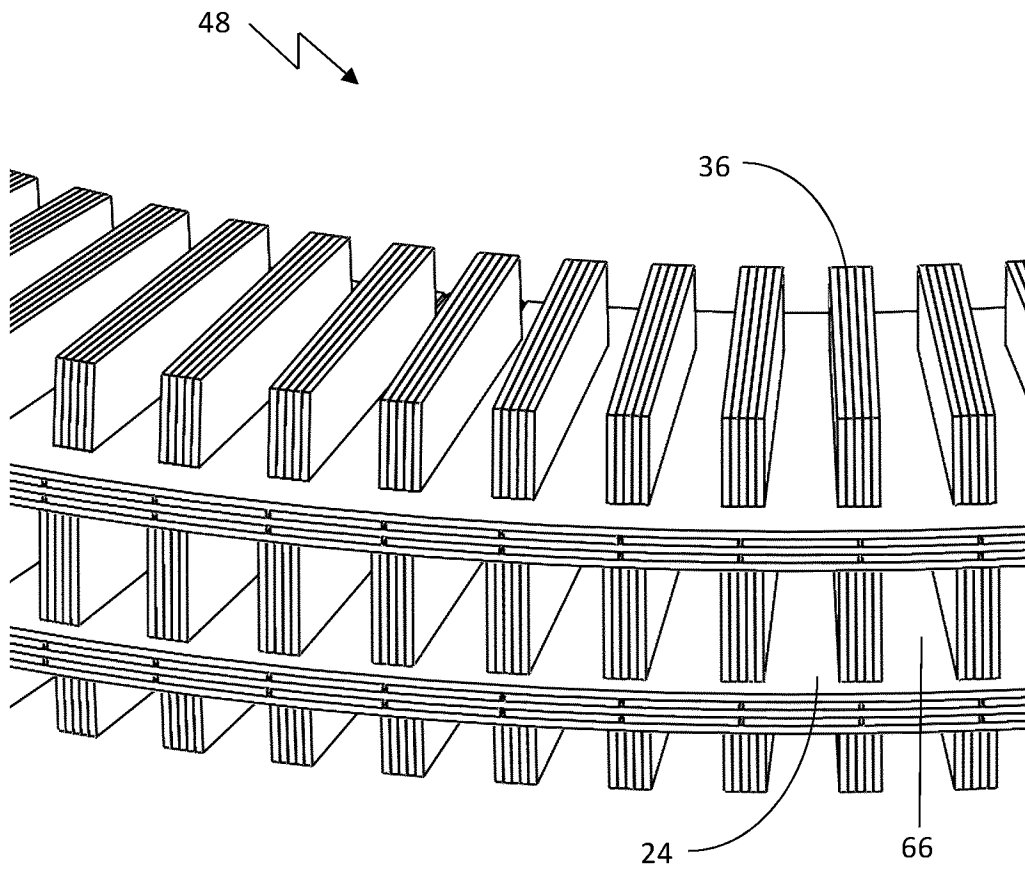

Fig. 8

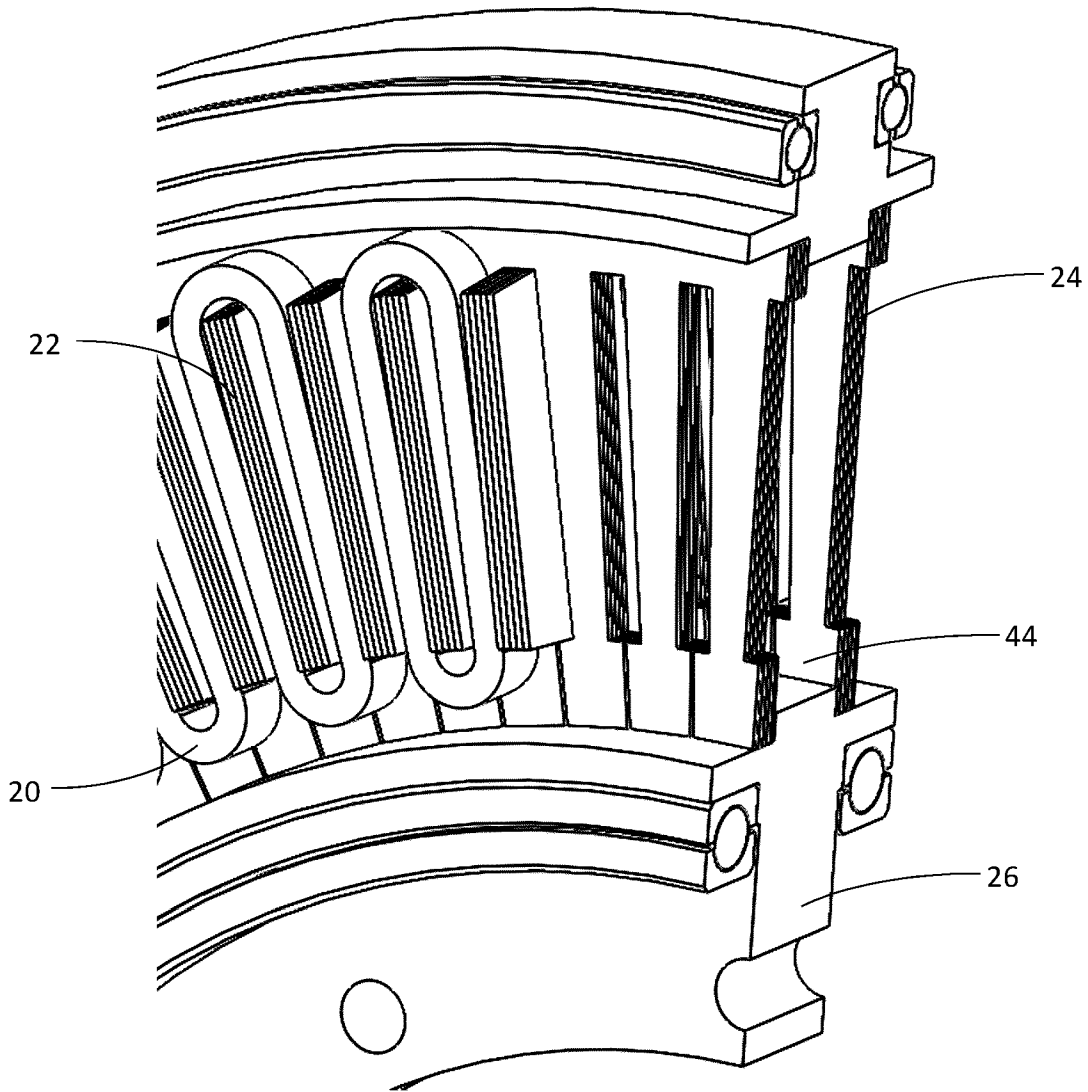

Fig. 9

INTERNATIONAL SEARCH REPORT

International application No.

PCT/CA2017/050858

A. CLASSIFICATION OF SUBJECT MATTER
 IPC: *H02K 1/16* (2006.01), *H02K 16/00* (2006.01), *H02K 7/08* (2006.01)

According to International Patent Classification (IPC) or to both national classification and IPC

B. FIELDS SEARCHED

Minimum documentation searched (classification system followed by classification symbols)
 H02K

Documentation searched other than minimum documentation to the extent that such documents are included in the fields searched

Electronic database(s) consulted during the international search (name of database(s) and, where practicable, search terms used)
 QUESTEL-ORBIT (FAMPAT); Keywords: "axial flux, axial gap, stator structure, two rotors, first rotor, first and second rotors"

C. DOCUMENTS CONSIDERED TO BE RELEVANT

Category*	Citation of document, with indication, where appropriate, of the relevant passages	Relevant to claim No.
X	D1: CN102624108; JING et al.; 30 July 2014 (30-07-2014) Figs. 1-5	1, 3-11 and 13-22
Y	D2: Libert et al.; "Investigation on Pole-Slot Combinations for Permanent-magnet Machines with concentrated windings"; Proc. ICEM, 2004, pp530-535, 31 December 2004 (31-12-2004); https://www.researchgate.net/profile/Juliette_Soulard/publication/237458473_Investigation_on_Pole-Slot_Combinations_for_Permanent-Magnet_Machines_with_Concentrated_Windings/links/0c960529dbd61c1be4000000.pdf Table I	2
Y	US6856063; KELECY et al.; 15 February 2005 (15-02-2005) Fig. 1; Column 5, lines 60-62	12

Further documents are listed in the continuation of Box C.

See patent family annex.

* "A" document defining the general state of the art which is not considered to be of particular relevance "E" earlier application or patent but published on or after the international filing date "L" document which may throw doubts on priority claim(s) or which is cited to establish the publication date of another citation or other special reason (as specified) "O" document referring to an oral disclosure, use, exhibition or other means "P" document published prior to the international filing date but later than the priority date claimed	"T" later document published after the international filing date or priority date and not in conflict with the application but cited to understand the principle or theory underlying the invention "X" document of particular relevance; the claimed invention cannot be considered novel or cannot be considered to involve an inventive step when the document is taken alone "Y" document of particular relevance; the claimed invention cannot be considered to involve an inventive step when the document is combined with one or more other such documents, such combination being obvious to a person skilled in the art "&" document member of the same patent family
---	--

Date of the actual completion of the international search
07 September 2017 (07-09-2017)

Date of mailing of the international search report
 18 September 2017 (18-09-2017)

Name and mailing address of the ISA/CA
 Canadian Intellectual Property Office
 Place du Portage I, C114 - 1st Floor, Box PCT
 50 Victoria Street
 Gatineau, Quebec K1A 0C9
 Facsimile No.: 819-953-2476

Authorized officer

Guillaume Murere (819) 934-6750

INTERNATIONAL SEARCH REPORT
Information on patent family members

International application No.

PCT/CA2017/050858

Patent Document Cited in Search Report	Publication Date	Patent Family Member(s)	Publication Date
CN102624108B	30 July 2014 (30-07-2014)	CN102624108A CN102624108B	01 August 2012 (01-08-2012) 30 July 2014 (30-07-2014)
US6856063B1	15 February 2005 (15-02-2005)	US6856063B1 US6768239B1	15 February 2005 (15-02-2005) 27 July 2004 (27-07-2004)