

1,069,496.

Patented Aug. 5, 1913.

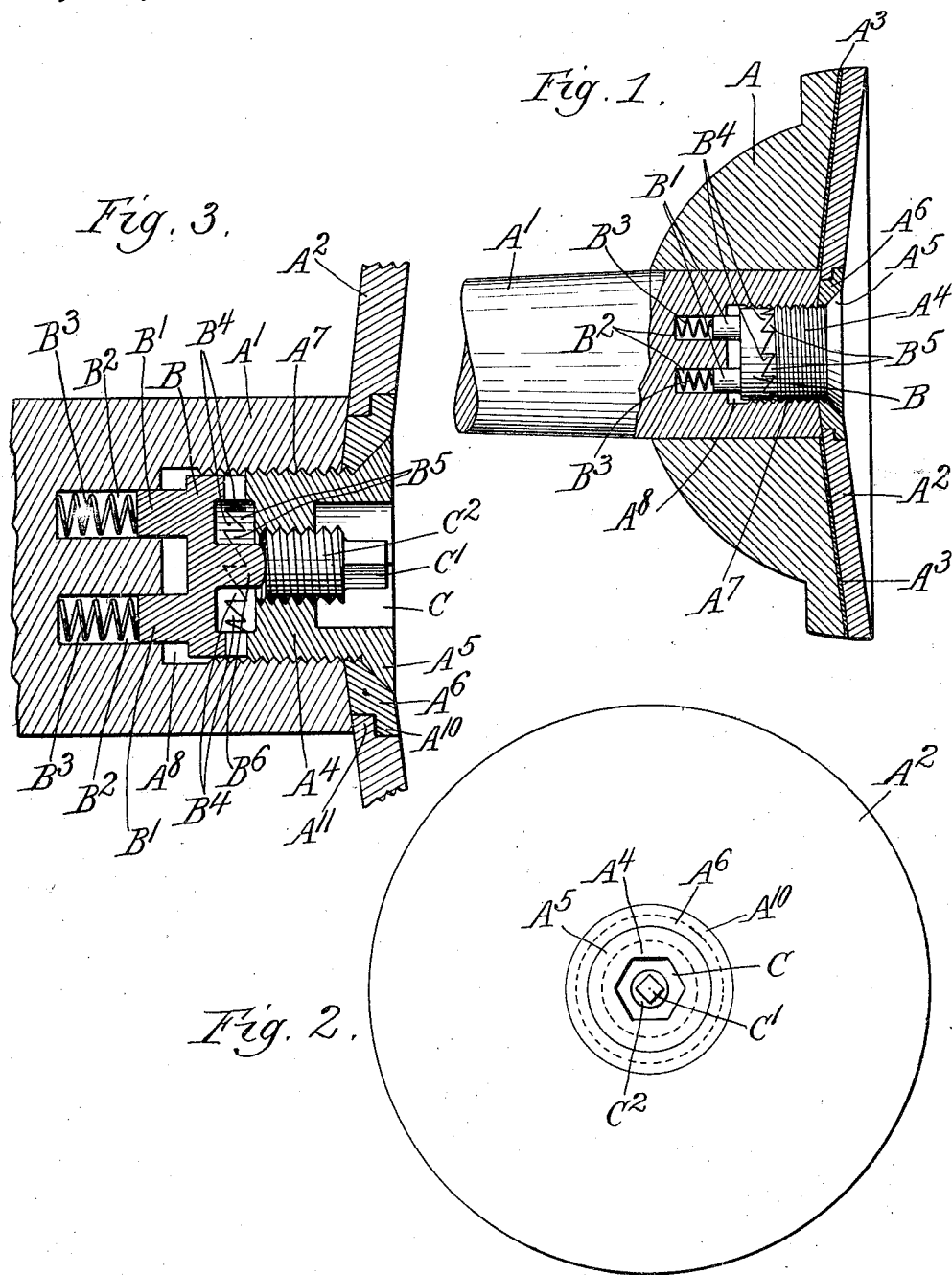

Witnesses,
 Edward T. Wray
 General Smith

Inventor,
 Edgar B. Symons.
 by Parker & Coates
 Attorneys.

UNITED STATES PATENT OFFICE.

EDGAR B. SYMONS, OF MILWAUKEE, WISCONSIN.

CRUSHING-MACHINE.

1,069,496.

Specification of Letters Patent.

Patented Aug. 5, 1913.

Original application filed January 26, 1910, Serial No. 540,119. Divided and this application filed April 1, 1912. Serial No. 687,661.

To all whom it may concern:

Be it known that I, EDGAR B. SYMONS, a citizen of the United States, residing at Milwaukee, in the county of Milwaukee and State of Wisconsin, have invented a certain new and useful Improvement in Crushing-Machines, of which the following is a specification.

My invention, which is a divisional application based on the subject matter divided out of my co-pending application No. 540,119 filed January 26, 1910, has for one object to provide new and improved means for fastening a crushing disk to a disk crusher as illustrated diagrammatically in one form in the accompanying drawing, wherein—

Figure 1 is a sectional view through the crusher head and disk showing fastening means in elevation. Fig. 2 a plan view of the disk. Fig. 3 a section through the fastening means.

Like parts are indicated by like letters throughout the several figures.

The spherical crusher head A, which is mounted on the shaft A¹, carries the dish shaped crushing member A² which is held against the backing A³ by the holding screw A⁴ which screw is provided with the conical head A⁵ in engagement with the conically apertured collar A⁶ rigidly held in central position in the disk A².

The collar A⁶ is provided about its periphery adjacent its upper side with the flange A¹⁰. This flange overlies a flange A¹¹, which projects inwardly from the crushing disk A² on its inner side thus forming a halved joint between the disk and the collar. The pressure may thus be exerted upon the collar to draw the disk against this seat without exerting any separating force upon the disk and any flowing of the metal of the disk which would tend to constrict the size of the aperture in which the collar is located will merely exert a pressure force upon the collar and exert no tendency toward throwing it out as would be the case if the engaging surfaces were inclined. Moreover the fact that the plane between the collar A⁶ and plate A² is normal to the line of pressure between them prevents the possibility of any wedging action which would tend to distort the plane or collar by forcing one into the other. The screw A⁴ is in engagement with the screw thread A⁷ on the inside

of the pocket A⁸ in the crusher head. The plate B, which is slidably mounted in the pocket A⁸, is provided with the lugs B¹ which project into the holes B² in the base of the pocket A⁸ and compress the spiral springs B³ to force the plate outwardly. The plate B is provided with the teeth B⁴ in opposition to the teeth B⁵ on the end of the screw A⁴ and has the lug B⁶ projecting upwardly beyond said teeth. The screw A⁴ is provided with the centrally disposed polygonal pocket C in which is located the squared end C¹ of the screw C² which is screw-threaded in the center of the screw A⁴ and is in opposition at its lower end to the lug B⁶.

It will be evident that, while I have shown in my drawing an operative device, still many changes might be made both in size, shape and arrangement of parts without departing materially from the spirit of my invention. I have illustrated my whole means as applied to a disk crusher having a disk shaped crushing disk and it will at once be evident that, while this device is primarily intended for use in such connection where the ordinary lock, nuts, bolts, etc., are likely to be damaged, still it might be used for a large number of situations and I wish therefore my drawings to be regarded in a sense diagrammatic.

The use and operation of my invention are as follows: It will be understood that the crushing disk will preferably be made of some tough or ductile material such as manganese steel which flows readily when great pressures are brought to bear upon it and this flowage will under ordinary circumstances have a tendency to constrict the material about any centrally disposed holding means and lock it in position and I provide, therefore, a centrally disposed washer of some other material which is designed to take up and resist such flowing and locking tendency. Any such material as is suited for a crushing disk will, it is at once evident, be unsuited for machining. It is therefore necessary to provide a soft metal backing which may be poured between the disk and the head to form a foundation for the crushing disk at all points. In assembling my device the inner screw located within the main holding screw is first screwed in. The locked disk is placed in the pocket in such manner that the lugs thereon extend into

the holes projecting therefrom and rest against the spiral springs. The disk is then put in place and the holding screw inserted through it and screwed into the pocket in the crushing head. The inner screw will rest against the lug projecting upwardly from the locking plate and hold it away from the end of the screw so as to keep the teeth out of register one with the other. When the holding screw has been tightened down into position in such manner that the conical head is pressed tightly against the conical surface in the washer the central screw is then screwed out sufficiently to enable the teeth on the locking disk to engage the teeth on the end of the screw thus holding the screw firmly in position and preventing its working out and releasing the disk.

I have stated that the flow of the metal in the crushing disk will have a tendency to constrict the central hole and this is likely to occur when the crushing forces are distributed pretty well over the surface of the disk, but if it happens that the crushing is localized about the periphery of the disk, there is a possibility that the extension which there takes place will be taken up by the metal and not permitted to reach the central hole, but if this occurs, there will be a tendency for the disk to flatten out and great pressure will then be exerted, tending to raise the center of the disk, and this pressure will under some circumstances be so great as in itself to cause a washer centrally disposed on the disk to grip the holding bolt. In view of the fact that this collar may be machined and made smooth and even, this tendency toward gripping of the holding bolt is of course materially minimized.

I claim:

1. In a crushing machine a crushing head and a disk, centrally disposed means for holding said disk in position thereon, said means comprising a centrally disposed single screw and means for preventing the disengagement of said screw.

2. In a crushing machine a crushing head and a disk and centrally disposed means for holding said disk in position thereon and means for protecting said holding device from the constrictive action of the disk.

3. In a crushing machine a crushing head and a disk, centrally disposed means for holding said disk in position thereon, said means comprising a screw and means for preventing the disengagement of said screw, and means for protecting said screw from the constrictive action of the disk.

4. In a crushing machine a crushing head and a disk and centrally disposed means for holding said disk in position thereon and means for protecting said holding device from the constrictive action of the disk, said

protecting means comprising a collar carried in the disk.

5. In a crushing machine a crushing head and a disk, centrally disposed means for holding said disk in position thereon, said means comprising a centrally disposed single screw and means for preventing the disengagement of said screw, and means for protecting said screw from the constrictive action of the disk, said protecting means comprising a collar carried in the disk.

6. In a crushing machine a crushing disk, a collar centrally disposed therein and a halved joint between said collar and said disk.

7. In a crushing machine a crushing disk, a collar centrally disposed therein having a conical bearing surface and a halved joint between said collar and said disk.

8. In a crushing machine a crushing disk of ductile flowing material and a centrally disposed annular compression member of resistant material.

9. In a crushing machine a crushing disk of ductile material, a centrally disposed collar therein of resisting material and a halved joint between said collar and said disk.

10. In a crushing machine a crushing head and a disk of ductile material, means for holding said disk in position thereon and means for protecting said holding means from any locking action caused by the flow of the ductile material of the disk.

11. In a crushing machine a crushing head and a disk of ductile material, means for holding said disk in position thereon and means for protecting said holding means from any locking action caused by the flow of the ductile material of the disk, said holding means comprising a screw.

12. In a crushing machine a crushing head and a disk of ductile material, means for holding said disk in position thereon and means for protecting said holding means from any locking action caused by the flow of the ductile material of the disk, said holding means comprising a screw, said protecting means comprising a collar surrounding the screw.

13. In a crushing machine a crushing disk, centrally disposed holding means therefor, a protecting collar interposed between said holding means and said disk and a conical contact between said collar and said holding means.

14. In a crushing machine a crushing disk, centrally disposed holding means therefor, a protecting collar interposed between said holding means and said disk and a halved joint between said collar and said disk.

15. In a crushing machine a crushing disk, centrally disposed holding means therefor, a protecting collar interposed be-

70

75

80

85

90

95

100

105

110

115

120

125

130

tween said holding means and said disk, a halved joint between said collar and said disk, and a conical contact between said disk and said holding means.

5 16. In a crushing machine a crushing disk of ductile material, a centrally disposed collar therein, means for holding said collar in position so that the constrictive action of the disk will not force it out of position.

10 17. In a crushing machine a crushing disk of ductile material, a centrally disposed collar therein, means for holding said washer in position so that the constrictive action of the disk will not force it out of position, 15 said means comprising a flange on the collar overlying a flange on the disk.

18. In a crushing machine a crushing head and a crushing disk, means comprising a screw for holding said disk thereon and 20 means comprising a conical head upon said screw in opposition to a conical bearing surface on the disk for centering the disk with respect to the head.

25 19. In a crushing machine a crushing disk and a centrally disposed holding screw

therein, means for holding said screw against rotation.

20. In a crushing machine a crushing disk and a centrally disposed holding screw 30 therein, means for holding said screw against rotation, and a device for disengaging said holding means.

21. In a crushing machine a crushing head and a crushing disk thereon, a collar 35 located within said crushing disk and holding means in opposition to and protected by said collar, the engaging surfaces of said disk and collar being partially abutting and partially overlying.

22. In a crushing machine a crushing 40 head, a crushing disk thereon, a collar centrally disposed in said crushing disk and holding means centrally disposed in said collar and protected thereby, the engaging 45 surfaces of said disk and collar being partially abutting and partially overlying.

EDGAR B. SYMONS.

Witnesses:

F. A. OTTO,

J. E. SYMONS.

Copies of this patent may be obtained for five cents each, by addressing the "Commissioner of Patents, Washington, D. C."