

T. SMITH.
BOILER SETTING.
APPLICATION FILED NOV. 6, 1917.

1,274,342.

Patented July 30, 1918.

2 SHEETS—SHEET 1.

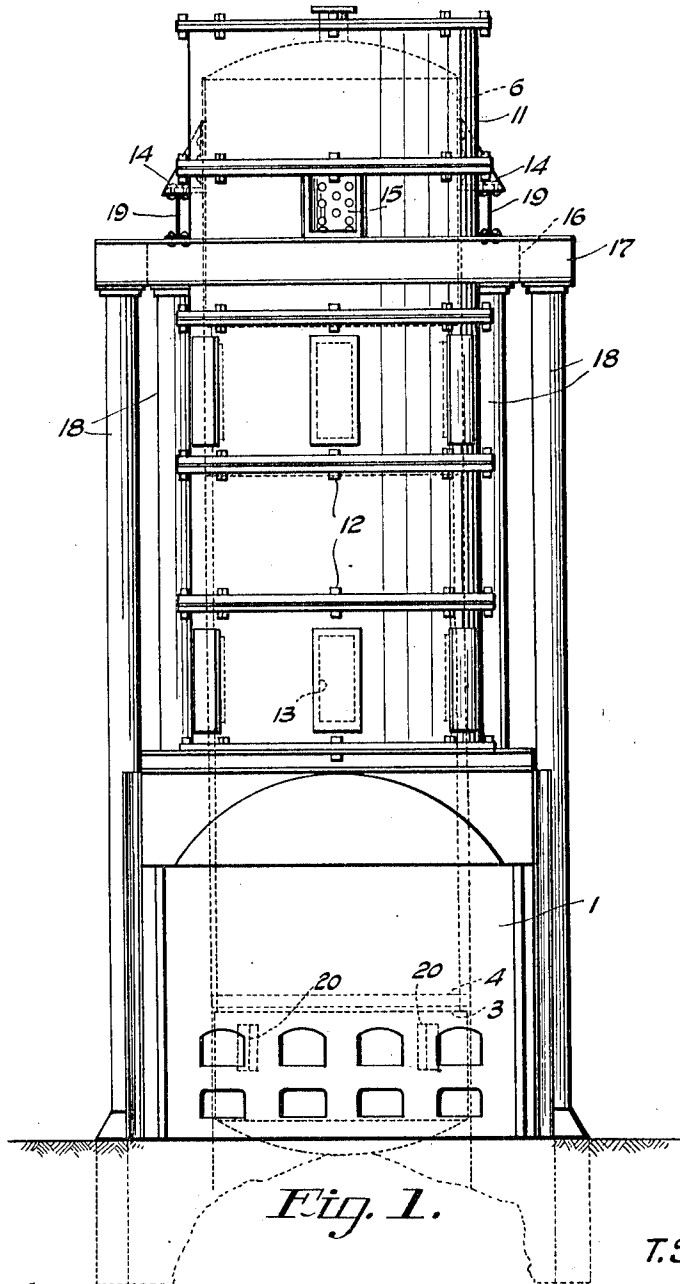

Fig. 1.

Witnesses
J. Gordon Sparks
Tomie H. H. H.

Inventor
T. Smith

By

Richard J. H. H.
Attorney

T. SMITH.
 BOILER SETTING.
 APPLICATION FILED NOV. 6, 1917.

1,274,342.

Patented July 30, 1918.

2 SHEETS—SHEET 2.

Fig. 2.

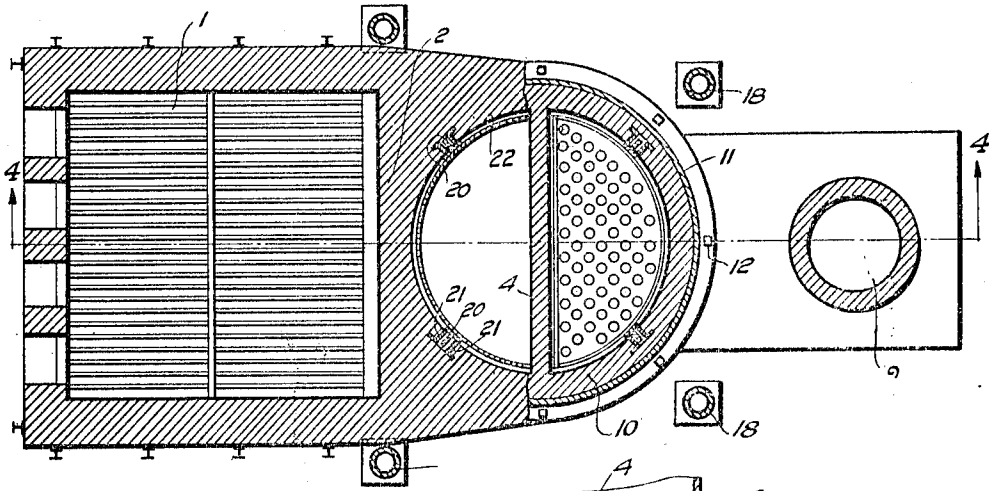

Fig. 3.

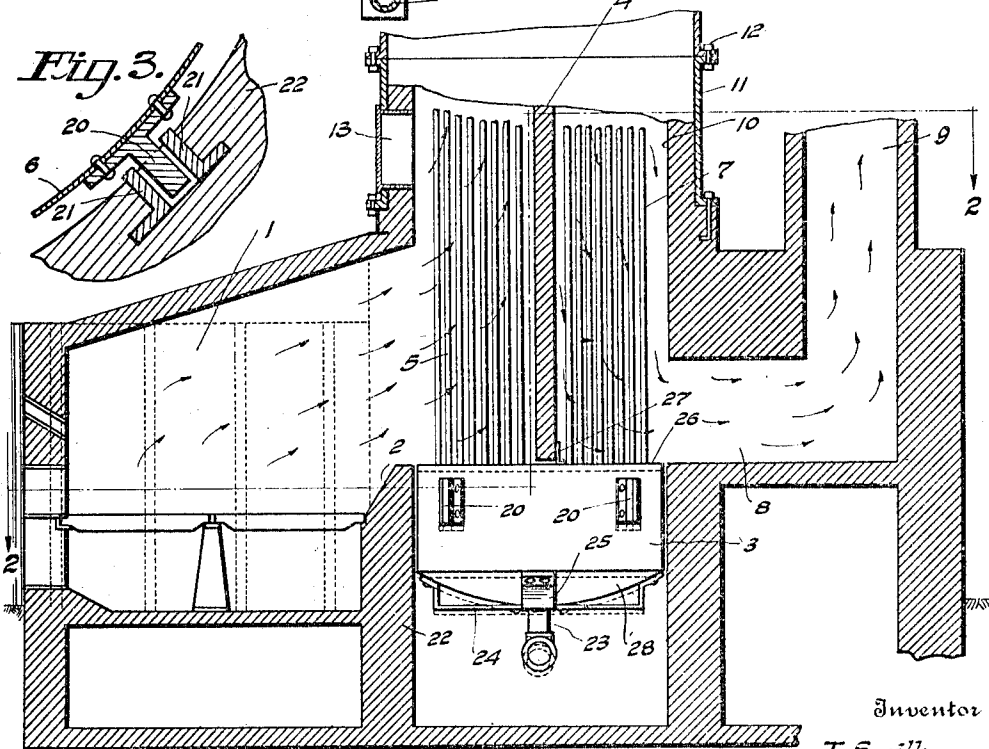

Fig. 4.

Witnesses
J. Gordon Spaulding
Conrad Helsh

BY

T. Smith
Robert A. Smith
 Attorney

UNITED STATES PATENT OFFICE.

THOMAS SMITH, OF BIRMINGHAM, ALABAMA.

BOILER-SETTING.

1,274,342.

Specification of Letters Patent. Patented July 30, 1918.

Application filed November 6, 1917. Serial No. 200,546.

To all whom it may concern:

Be it known that I, THOMAS SMITH, a citizen of the United States of America, residing at Birmingham, in the county of Jefferson and State of Alabama, have invented certain new and useful Improvements in Boiler-Settings, of which the following is a specification.

My invention relates to a setting for vertical tubular boilers, my object being to support the boilers that the tubes are relieved of the compression load of the upper drum and are left free to follow their normal expansion and contraction movements in doing which they carry with them the lower drum which hangs free for vertical movement in its setting.

My invention is more particularly adapted to boilers of the Wicks or Rust type and in the preferred arrangement of my setting I utilize metallic columns and structural beams which are disposed without the boiler casing and which have suitable connections to the upper drum so as to support the entire boiler from that point and relieve the setting and boiler tubes of the load.

A further advantage of my arrangement is to hold the boiler in proper alinement, this being accomplished by the reinforcing frame work which is so disposed as to be unaffected by any excessive temperature conditions in the boiler.

Another feature of my invention relates to the manner of baffling the flow of hot gases between the banks of tubes, this baffle being preferably tied to the brick work and connected by an expansion joint with the movable lower drum which prevent the short circuiting of gases under the baffle.

My invention comprises the novel details of construction and arrangement of parts, which in their preferred embodiment only are illustrated in the accompanying drawings, in which:—

Figure 1 shows in front elevation a vertical tubular boiler equipped with my novel setting and reinforcing frame work.

Fig. 2 is a sectional view taken on the line 2—2 of Fig. 4.

Fig. 3 is a detail view of one of the guides for the lower drum.

Fig. 4 is a partial vertical sectional view taken on the line 4—4 of Fig. 2.

Similar reference numerals refer to similar parts throughout the drawings.

The brick work setting of the boiler and

its general arrangement of drums and tubes may be of any standard vertical tubular boiler design. As shown, the furnace 1 delivers hot gases over a bridge wall 2 and above the bottom drum 3, these gases being deflected upwardly by means of a vertical baffle wall 4 so that they pass through the bank of tubes 5 to the bottom of the upper drum 6 between which and the baffle they pass and return downwardly through the bank of tubes 7 to the outlet port 8 and thence to the stack 9. The tubes are surrounded by the ordinary brick work setting 10 disposed within the cylindrical metal casing sections 11 which are flanged and connected by bolts 12 and which are provided with holes 13 for blowing off the tubes with a steam jet. The upper drum 6 is mounted rigidly in the brick setting and has riveted thereto two pairs of brackets 14 and 15. Both pairs of brackets project outwardly through the setting and upper casing member 11 and the brackets 15 are mounted on and riveted to two parallel I-beams 16 and 17 which at their outer ends are supported by four pipe columns 18 located substantially at what may be termed the four corners of the brick work setting for the boiler proper. Two I-beams 19 are disposed on each side of the boiler and supported on the I-beams 16 and 17 serve to support the brackets 14. The columns are preferably of heavy double strength iron pipe, or steel tubing may be used and they are suitably mounted on any base foundation and can readily be set up adjacent to boilers now in service or hereafter to be installed. The structural frame work comprising the members 16, 17 and 19 may be made up of other types of beams or guides but those described are most satisfactory.

The lower drum 3 is suspended from the upper drum by the tubes 5, 7 being so mounted in the brick work setting that it is free to move up and down vertically in response to the expansion and contraction of the tubes so as to relieve them of any undue strains and stresses resulting from variation heat conditions. It is desirable, however, to prevent the lower drum from twisting or tilting out of proper alinement and putting a strain from that cause on the tubes and to this end I mount on the lower drum a plurality of T-shaped guides 20 having their curved bases riveted to the drum 6 with their webs vertically disposed and adapted to be

received in guides formed by angle bars 21 which are set in spaced relationship in the brick work setting 22. These guides allow free vertical play for the lower drum but hold it against lateral displacement. The lower drum is provided with the usual blow-out connection 23 and inasmuch as in the case of repairs it will be desirable to jack up the lower drum, I attach to the convex bottom 28 of the drum a bracket 24 which comprises a horizontal bottom portion having four upturned flanges 25 which are riveted to the bottom 28, access being had through the setting 22 to the space below the drum so that it is a simple matter to insert jacks and to lift or adjust the boiler as a whole.

The baffle wall 4, if it were mounted upon the lower drum would, add its load thereto without special beneficial function and this I prefer to avoid by tying the baffle into the brick lining 10 of the metal casing and to prevent short circuiting of the gases under the baffle when the tubes are expanded, I rivet to the tube sheet 26 of the lower drum 3 a transversely disposed angle bar 27, the vertical member of which abuts against the cooler face of the baffle wall and extends sufficiently above its bottom edge to close the maximum joint that will open between the baffle and the drum 3 when the tubes are fully expanded.

With the boiler thus mounted in its setting, its free suspension should greatly increase its life and service and its steam generating capacity would be entirely unaffected by the arrangement.

Having thus described my invention, what I claim as new and desire to secure by Letters Patent, is:—

1. In a vertical tubular boiler, upper and

lower drums, vertical tubes connecting the drums, a brick work setting for the drums, the setting for the lower drum comprising vertical guides, co-acting guides on the lower drum to permit a free movement only in a vertical direction, external columns free of the brick work setting, horizontal tie members connecting the upper ends of said columns, and brackets mounted on said tie members and penetrating the setting for the upper drum and made fast to said upper drum for supporting both drums from said external frame work, substantially as described.

2. In a vertical tubular boiler having upper and lower cylindrical vertically disposed drums and vertical tubes connecting them, of a brick work setting for the lower drum, co-acting guides on said drum and setting for confining the movements of the drum in a vertical direction, a metallic casing surrounding the tubes and inclosing the upper drum, a thin brick work lining within said casing, a baffle tied into said brick work setting and extending from the lower drum to a point near the upper drum, a transverse flange forming an expansion joint between the lower drum and the lower end of said baffle, external columns standing clear of said casing, horizontal tie members connecting said columns, and brackets resting on said tie members and extending through the casing and upper setting and rigidly tied to the upper drum to support the load of both drums and tubes, substantially as described.

In testimony whereof I affix my signature.

his
THOMAS X SMITH.
mark.

Witnesses:

NOMIE WELSH,
J. GORDON SPARKES.

Copies of this patent may be obtained for five cents each, by addressing the "Commissioner of Patents, Washington, D. C."