

# S. TORREY. Reciprocating Steam-Engines.

No. 133,813.

Patented Dec. 10, 1872.

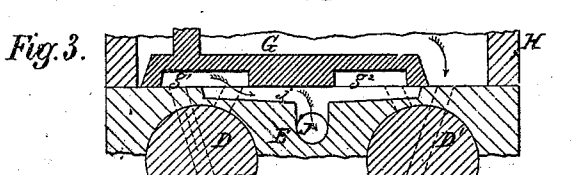
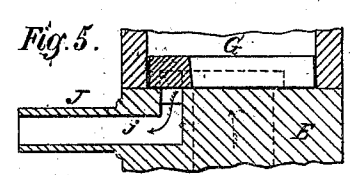
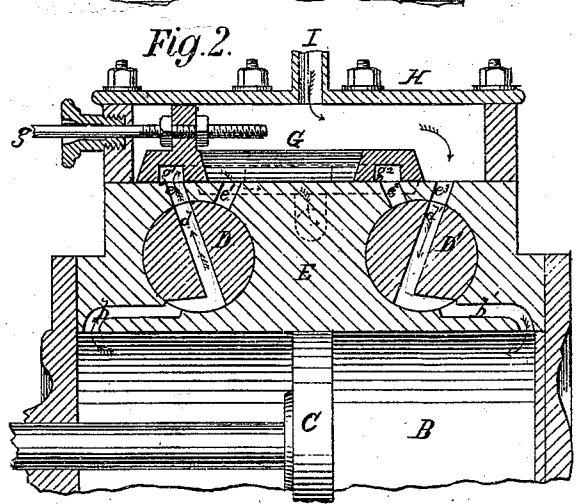
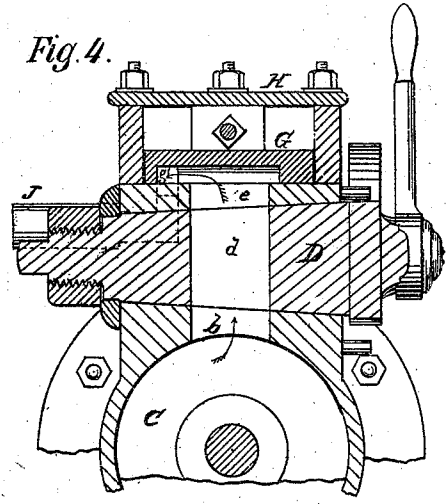
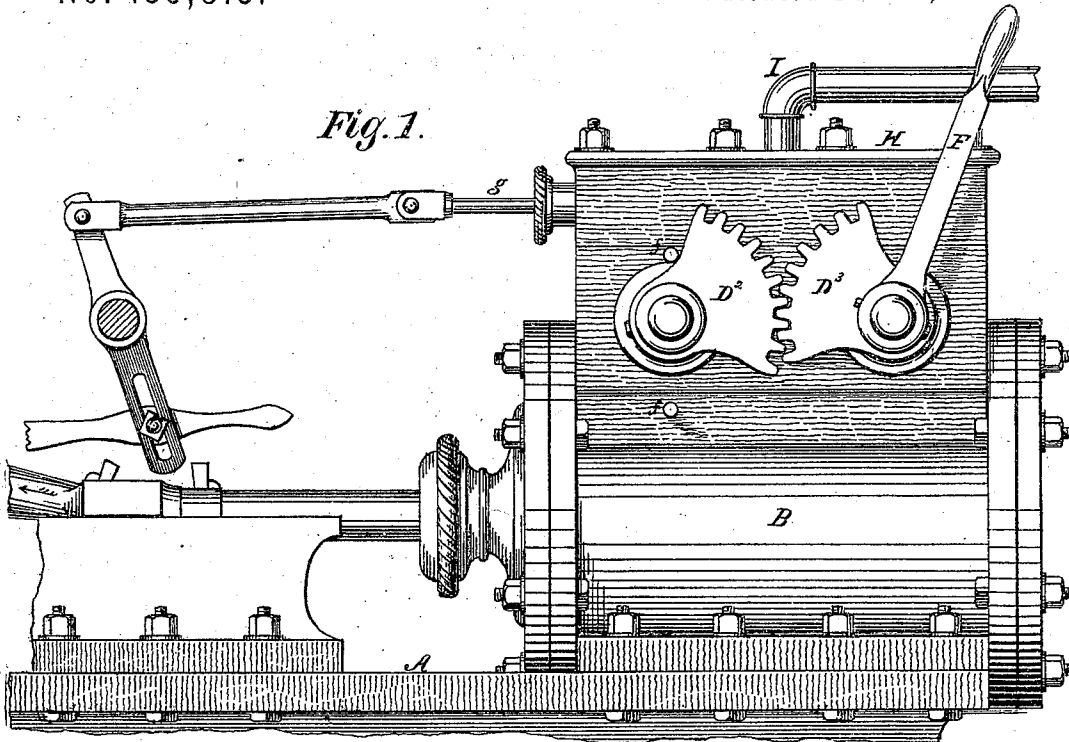

Witnesses:  
*Frederick Taylor,*  
*E. Davidson,*

Inventor:  
*Silas Torrey,*  
 by his atty  
*Wm D. Baldwin*

S. TORREY.

Reciprocating Steam-Engines.

No. 133,813.

Patented Dec. 10, 1872.

Fig. 7.

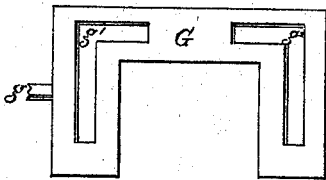

Fig. 6.

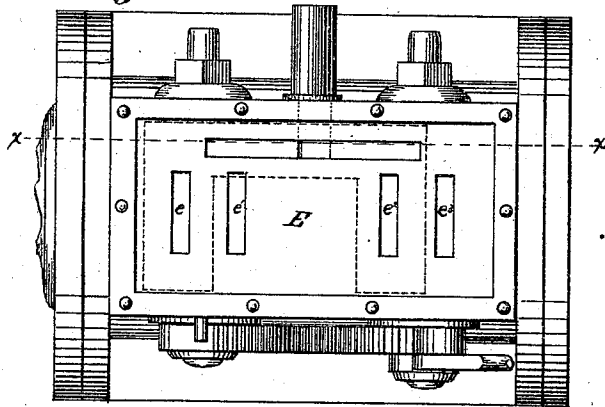
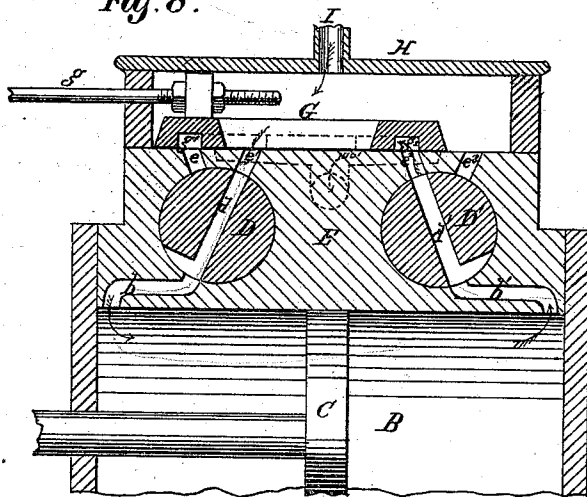

Fig. 8.



Witnesses:

*Joel P. Taylor*  
*E. C. Davidson*

Inventor:

*Silas Torrey*  
*by his Atty.*  
*Wm. D. Baldwin.*

# UNITED STATES PATENT OFFICE.

SILAS TORREY, OF TOLEDO, OHIO.

## IMPROVEMENT IN RECIPROCATING STEAM-ENGINES.

Specification forming part of Letters Patent No. 133,813, dated December 10, 1872.

*To all whom it may concern:*

Be it known that I, SILAS TORREY, of Toledo, in the county of Lucas and State of Ohio, have invented certain new and useful Improvements in Steam-Engines, of which the following is a specification:

My invention relates to steam-engines of that class having reversing-valves between the steam-chest and cylinder, whereby the motion of the engine may be reversed without changing the slide-valve. Its objects are to secure this reversal in a simple and effective way, and to economize steam by the use of short steam-passages between the steam-chest and cylinder; to which ends the improvement consists in interposing between the cylinder and the steam-chest in which the slide-valve works an intermediate steam-chest having extra ports at each end corresponding with the usual ports of the cylinder, and provided with proper valves and reversing-gear, as hereinafter more fully specified.

In the accompanying drawing, which represents my improvements as embodied in the best form now known to me, Figure 1 represents a side elevation of so much of an engine embracing my improvements as is necessary to illustrate the subject-matter claimed; Fig. 2 represents a vertical longitudinal central section through the cylinder and steam-chests with the parts in the relation they assume when the engine is going ahead; Fig. 3 represents a vertical longitudinal section through the exhaust-ports on the line  $x x$  of Fig. 6; Fig. 4 represents a transverse section through the valve-chests and cylinder in the axial line of one of the reversing-valves; Fig. 5 represents a vertical section through the exhaust-pipe; Fig. 6 represents a plan view of the supplementary steam-chest, the slide-valve chest being removed; Fig. 7 represents a view of the under side of the slide-valve; and Fig. 8 shows a section similar to Fig. 2, but with the engine reversed.

In this instance a cylinder, B, is shown as secured upon a firm bed-plate, A. A piston-head, C, fits and traverses this cylinder in the usual way. Ports  $b b'$ , at each end of the cylinder, connect with steam-passages  $d d'$  through faucet-valves  $D D^1$ , turning in steam-tight sockets in a steam-chest, E, having a

double set of ports,  $e e^1 e^2 e^3$ , at each end, either set being capable of being connected with the passages  $d d'$ , as hereinafter explained. The valves  $D D^1$  are operated by means of a hand-lever, F, and two interlocking sector-gears  $D^2 D^3$ , each gear being mounted on the arbor of its respective valve. Stops  $f f$  limit the movement of the valves. A valve, G, slides on top of the chest E over the ports  $e e^1 e^2 e^3$ , its throw being regulated by the valve-rod  $g$  and its connections, as usual.

In operation, steam enters the slide-valve chest H through the induction-pipe I, and (with the parts in the relation shown in Figs. 1 to 6 inclusive) passes down the passages  $e^3$ ,  $d'$ , and  $b'$  to the cylinder, as shown by the arrows in Fig. 2. The other ports are covered by the slide-valve. The steam, escaping from that end of the cylinder toward which the piston-head is moving, passes up through the passages  $b, d, e, g^1$ , and  $j$  to the exhaust-pipe J. The details of these parts are clearly shown in the drawing, and, being well known to skillful engine-builders, need not be here described. On the reverse stroke of the engine, the slide-valve moves far enough to clear the port  $e$  and to cover the port  $e^3$  with the exit-port  $g^2$ , the valves  $D D^1$  remaining stationary; the steam then enters through the valve D and escapes through the valve  $D^1$ , these motions being repeated at every reciprocation of the piston-head. To reverse the motion of the engine, the engineer, without disturbing the slide-valve, rocks the faucet-valves  $D D^1$  in their bearings, by means of the hand-lever F, until the parts assume the attitude shown in Fig. 8. This movement closes the ports  $e e^3$ , and opens those  $e^1 e^2$ . The steam now passes to the cylinder through the ports  $e^1, d,$  and  $b$ , until the stroke is completed, the escaping steam passing through the ports  $b', d', e^2,$  and  $g^2$ . On the reversal of the stroke the slide-valve opens the port  $e^2$  and covers that  $e^1$ , and exhausts the full end of the cylinder, as above explained.

I am thus, by my invention, enabled materially to diminish the length of the steam-passages, and consequently the amount of steam wasted, by using two short steam-passages between each set of the slide and faucet valves, and a single direct connection between each

of the faucet-valves and the cylinder, instead of reversing this arrangement. Simplicity and economy, as well as efficiency, are secured by this arrangement.

I do not broadly claim interposing reversing-valves between the cylinder and slide-valve.

I claim as my invention—

The combination of the cylinder, the reversing-valves, the single steam-passages connecting the cylinders and reversing-valves, the

slide-valve, and the double set of ports connecting the slide and reversing valves, these members being constructed and arranged to operate substantially as set forth.

In testimony whereof I have hereunto subscribed my name.

SILAS TORREY.

Witnesses:

WAGER SWAYNE,

HARRISON FITTS.