



US00RE42195E

(19) **United States**
(12) **Reissued Patent**
Bash et al.

(10) **Patent Number:** **US RE42,195 E**
(45) **Date of Reissued Patent:** ***Mar. 1, 2011**

(54) **ENERGY EFFICIENT CRAC UNIT OPERATION USING HEAT TRANSFER LEVELS**

(56) **References Cited**

(75) Inventors: **Cullen E. Bash**, Los Gatos, CA (US);
Ratnesh K. Sharma, Union City, CA (US);
Abdlmonem Beitelmal, Los Altos, CA (US)

U.S. PATENT DOCUMENTS
5,390,505 A * 2/1995 Smith et al. 62/173
5,538,471 A * 7/1996 Guiles, Jr. 454/239
6,732,540 B2 * 5/2004 Sugihara et al. 700/276
2004/0141542 A1 7/2004 Sharma et al.
2005/0023363 A1 2/2005 Sharma et al.

(73) Assignee: **Hewlett-Packard Development Company, LP**, Houston, TX (US)

FOREIGN PATENT DOCUMENTS

(*) Notice: This patent is subject to a terminal disclaimer.

JP 01219434 9/1989

* cited by examiner

(21) Appl. No.: **11/594,721**

(22) Filed: **Nov. 8, 2006**

Primary Examiner—Charles R Kasenge

Related U.S. Patent Documents

(57) **ABSTRACT**

Reissue of:

(64) Patent No.: **7,010,392**
Issued: **Mar. 7, 2006**
Appl. No.: **10/853,522**
Filed: **May 26, 2004**

A method for controlling one or more computer room air conditioning (CRAC) units for energy efficient operation, in which, the temperature of the air returned (Trat) into the one or more CRAC units and the temperature of the air supplied (Tsat) by the one or more CRAC units is detected. The caloric heat transfer level (Q) is calculated based upon the Trat and the Tsat and it is determined whether the Q is within a predetermined setpoint caloric heat transfer range. In addition, at least one operation of the one or more CRAC units is reduced in response to the Q being within the predetermined setpoint caloric heat transfer range to thereby increase the efficiencies of the one or more CRAC units.

(51) **Int. Cl.**
G05D 23/00 (2006.01)

(52) **U.S. Cl.** **700/276; 700/278; 700/300; 62/177**

(58) **Field of Classification Search** **700/276, 700/291, 293, 299, 300, 278; 62/173, 177, 62/180; 454/239; 705/400**

See application file for complete search history.

21 Claims, 7 Drawing Sheets

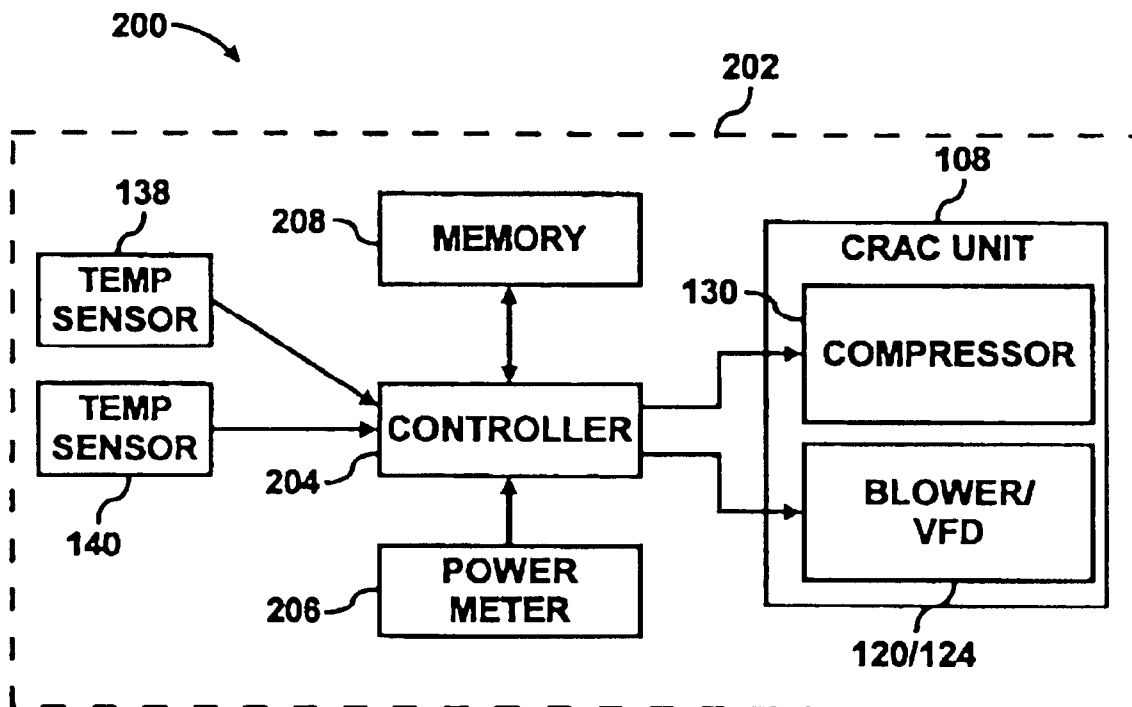

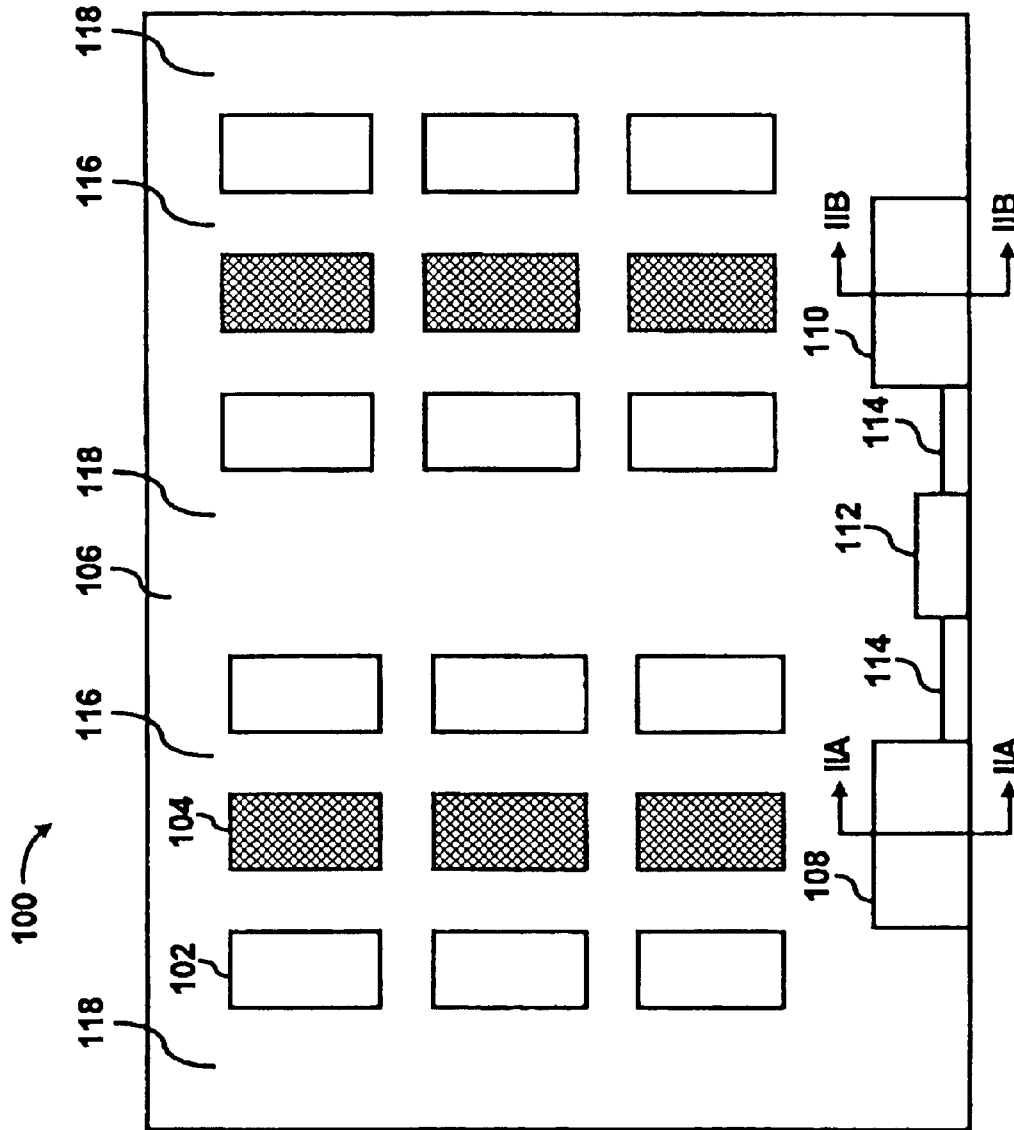

FIG. 1A

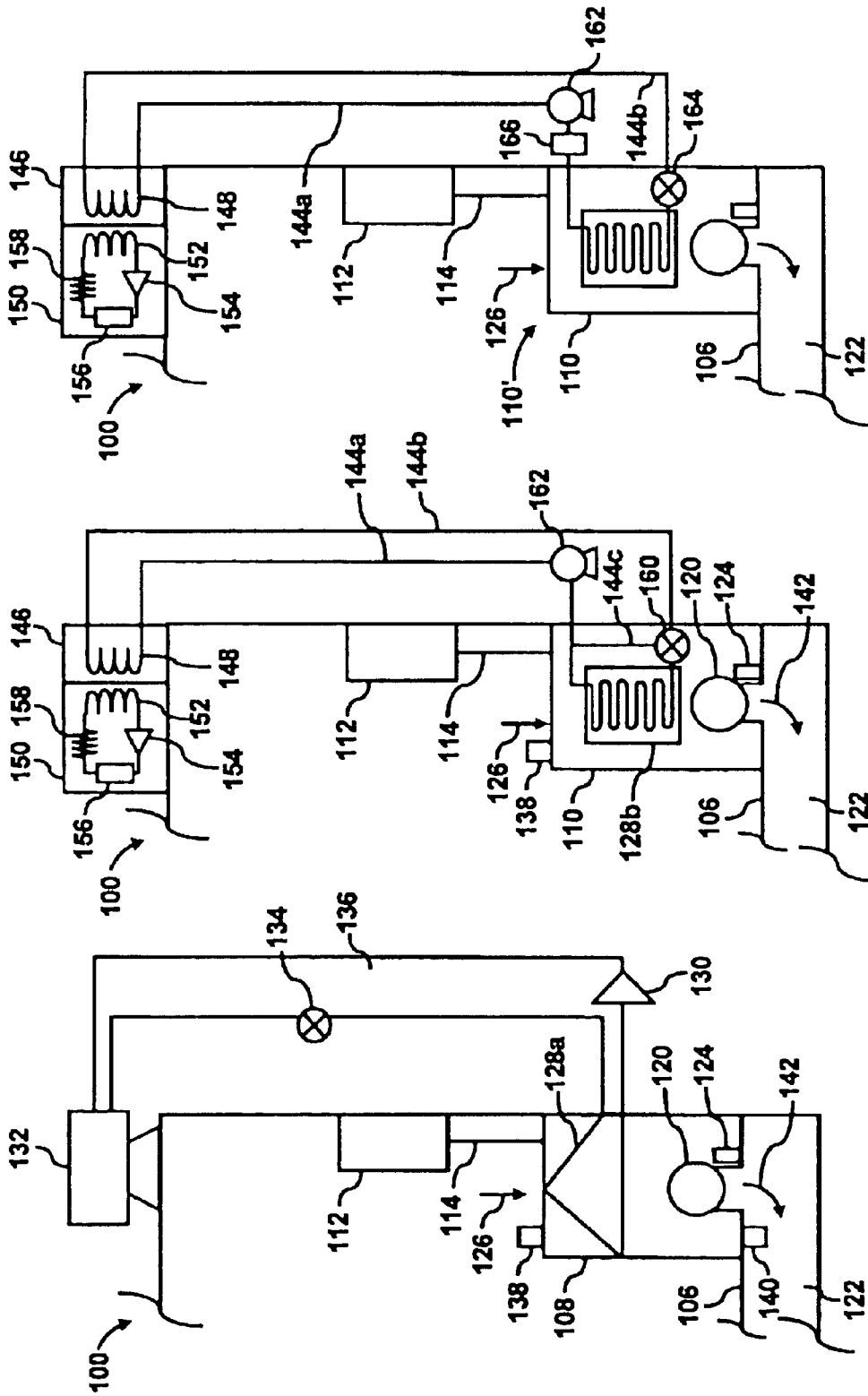

FIG. 1D

FIG. 1C

FIG. 1B

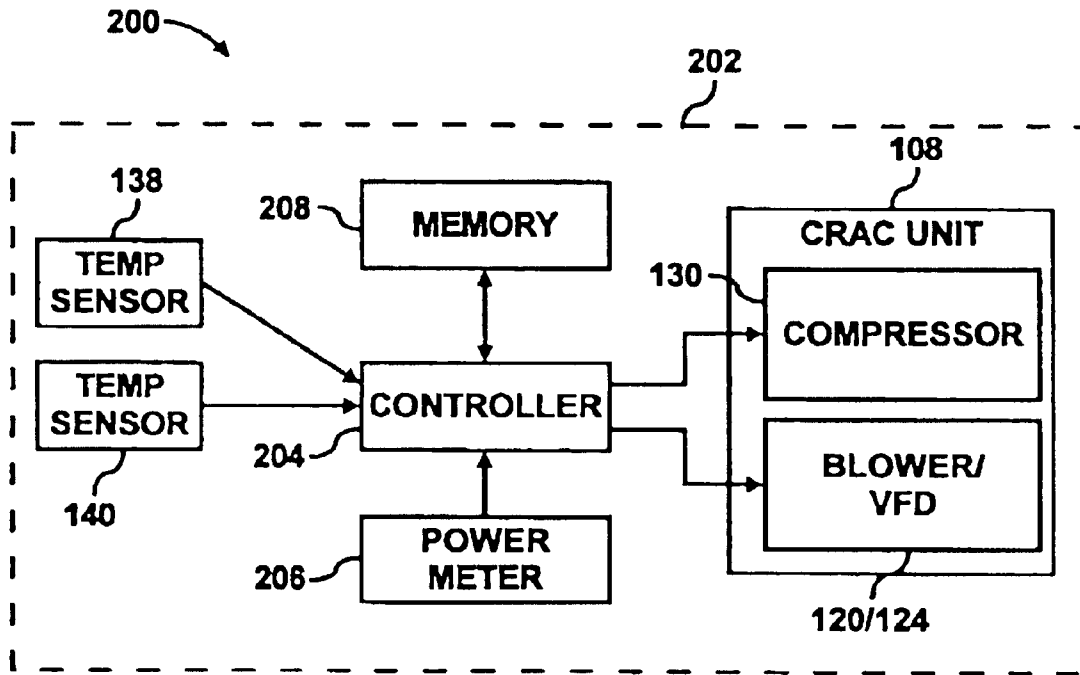

FIG. 2A

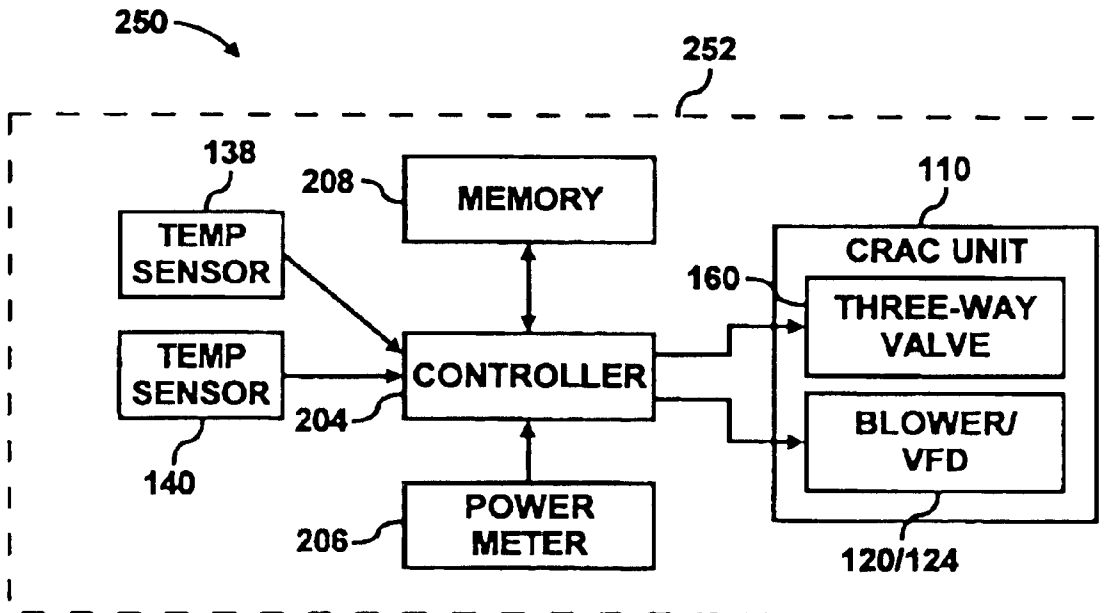

FIG. 2B

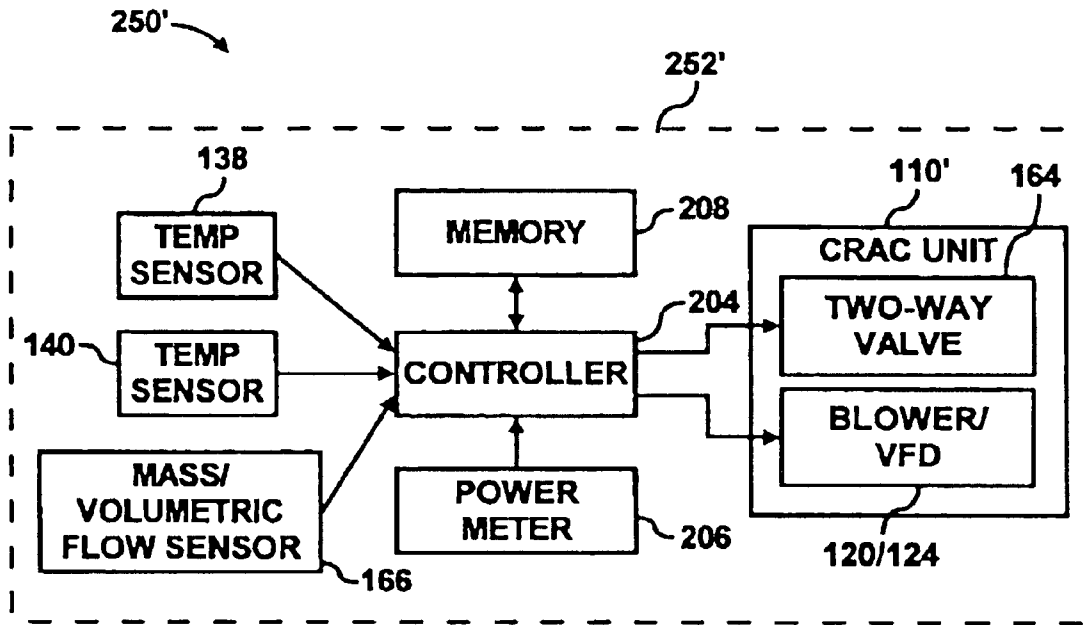

FIG. 2C

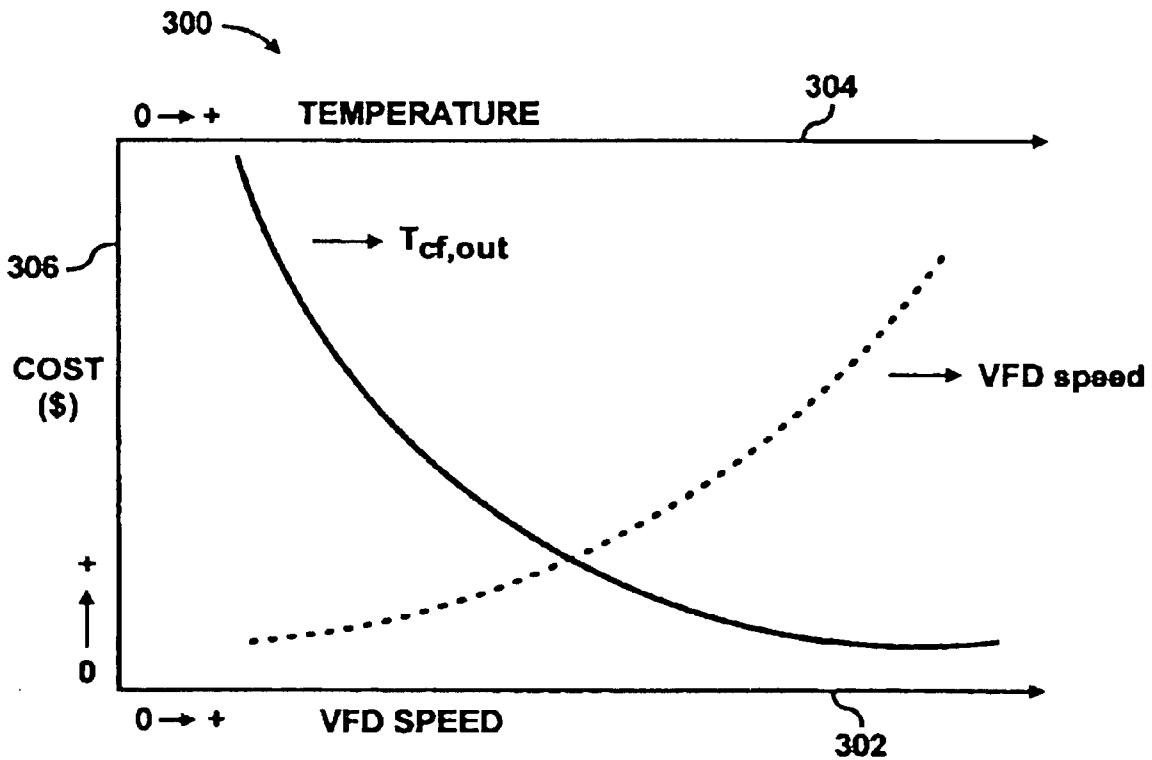

FIG. 3

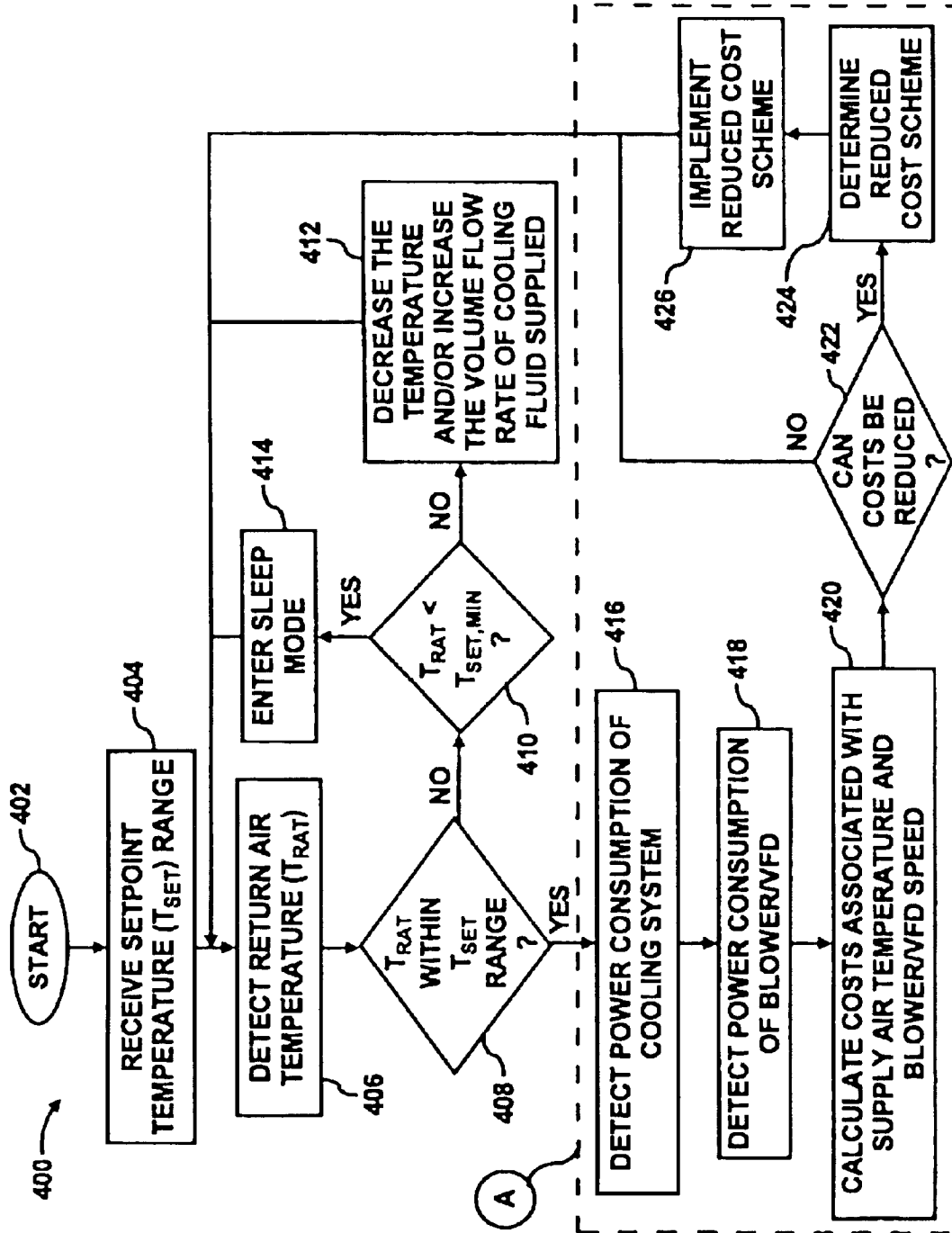

FIG. 4A

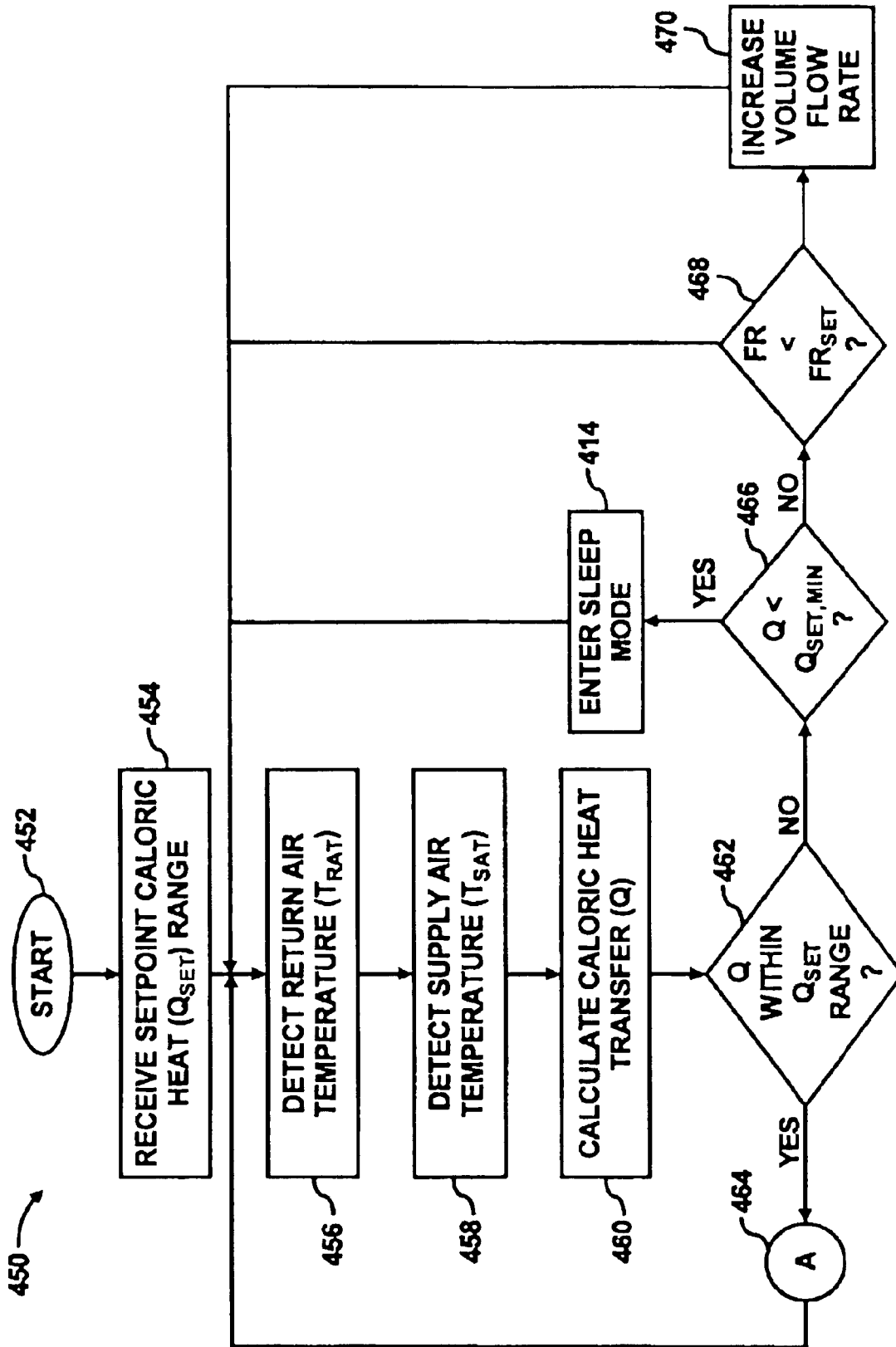

FIG. 4B

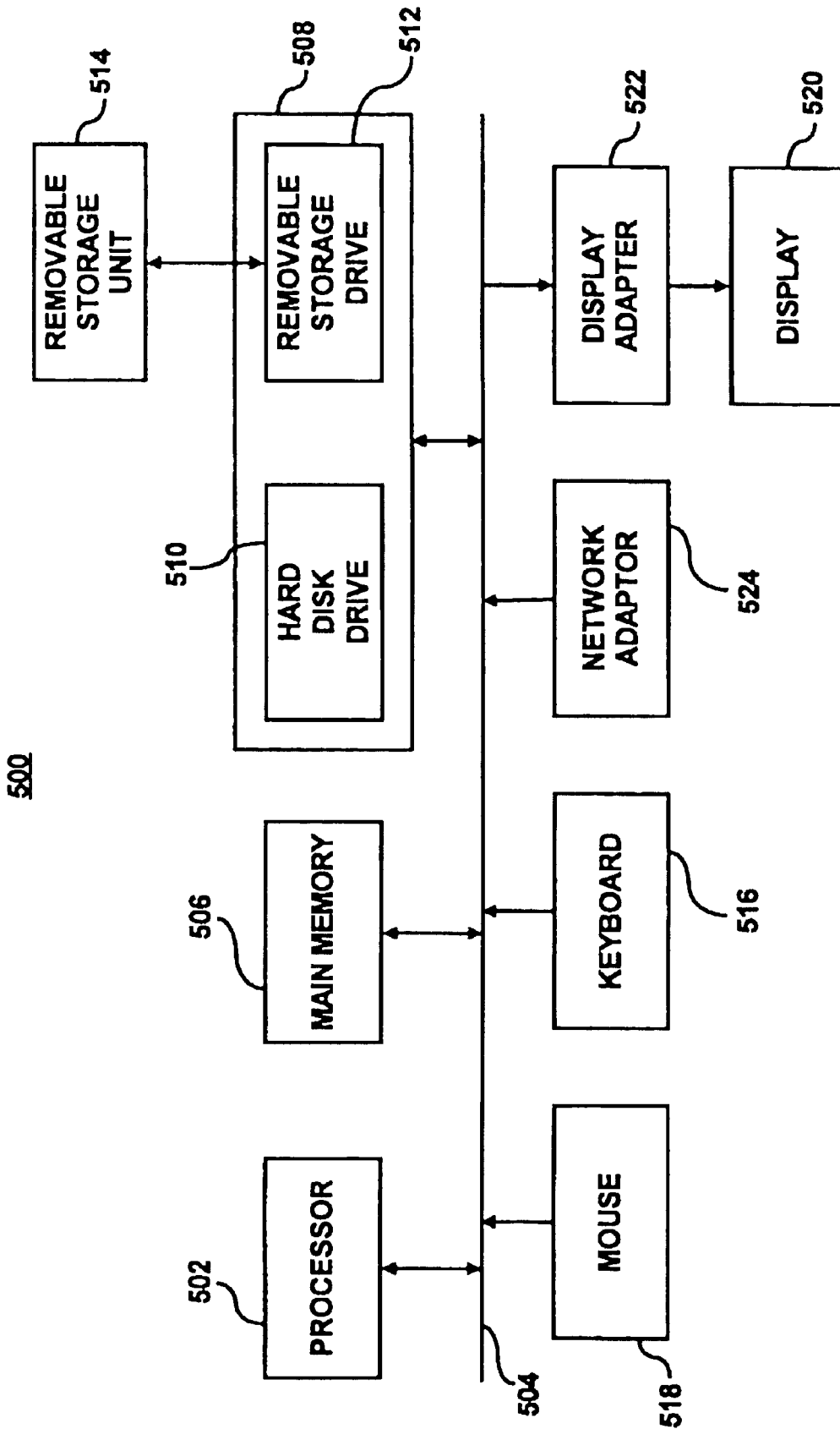

FIG. 5

**ENERGY EFFICIENT CRAC UNIT
OPERATION USING HEAT TRANSFER
LEVELS**

Matter enclosed in heavy brackets [] appears in the original patent but forms no part of this reissue specification; matter printed in italics indicates the additions made by reissue.

BACKGROUND OF THE INVENTION

A data center may be defined as a location, for instance, a room, that houses computer systems arranged in a number of racks. A standard rack, for example, an electronics cabinet, is defined as an Electronics Industry Association (EIA) enclosure, 78 in. (2 meters) high, 24 in. (0.61 meter) wide and 30 in. (0.76 meter) deep. These racks are configured to house a number of computer systems, about forty (40) systems, with future configurations of racks being designed to accommodate 200 or more systems. The computer systems typically include a number of printed circuit boards (PCBs), mass storage devices, power supplies, processors, micro-controllers, and semi-conductor devices, that dissipate relatively significant amounts of heat during their operation. For example, a typical computer system comprising multiple microprocessors dissipates approximately 250 W of power. Thus, a rack containing forty (40) computer systems of this type dissipates approximately 10 KW of power.

The power required to transfer the heat dissipated by the components in the racks to the cool air contained in the data center is generally equal to about 10 percent of the power needed to operate the components. However, the power required to remove the heat dissipated by a plurality of racks in a data center is generally equal to about 50 percent of the power needed to operate the components in the racks. The disparity in the amount of power required to dissipate the various heat loads between racks and data centers stems from, for example, the additional thermodynamic work needed in the data center to cool the air. In one respect, racks are typically cooled with fans that operate to move cooling air across the heat dissipating components; whereas, data centers often implement reverse power cycles to cool heated return air. The additional work required to achieve the temperature reduction, in addition to the work associated with moving the cooling fluid in the data center and the condenser, often add up to the 50 percent power requirement. As such, the cooling of data centers presents problems in addition to those faced with the cooling of the racks.

Conventional data centers are typically cooled by operation of one or more computer room air conditioning (CRAC) units. For example, compressors of CRAC units typically consume a minimum of about thirty (30) percent of the required operating energy to sufficiently cool the data centers. The other components, for example, condensers and air movers (fans), typically consume an additional twenty (20) percent of the required total operating energy. As an example, a high density data center with 100 racks, each rack having a maximum power dissipation of 10 KW, generally requires 1 MW of cooling capacity. CRAC units with a capacity of 1 MW of heat removal generally requires a minimum of 300 KW input compressor power in addition to the power needed to drive the air moving devices, for instance, fans and blowers. Conventional data center CRAC units do not vary their cooling fluid output based on the distributed needs of the data center. Instead, these CRAC units generally operate at or near a maximum compressor power level even when the heat load is reduced inside the data center.

The substantially continuous operation of the CRAC units is generally designed to operate according to a worst-case scenario. For example, CRAC units are typically designed around the maximum capacity and redundancies are utilized so that the data center may remain on-line on a substantially continual basis. However, the computer systems in the data center may only utilize around 30–50% of the maximum cooling capacity. In this respect, conventional cooling systems often attempt to cool components that may not be operating at a level which may cause their temperatures to exceed a predetermined temperature range. Consequently, many conventional cooling systems often incur greater amounts of operating expenses than may be necessary to sufficiently cool the heat generating components contained in the racks of data centers.

Other types of conventional CRAC units are configured to vary the temperature of the cooling fluid as well as the volume flow rate of the cooling fluid supplied into the data center. These types of CRAC units often include cooling systems configured to vary the temperature of the received cooling fluid prior to delivery into the data center. The cooling systems include variable capacity compressors and chilled water systems. In addition, these CRAC units also include blowers with variable frequency drives configured to vary the volume flow rate of the cooling fluid delivered into the data center.

The temperatures to which the cooling systems cool the cooling fluid received from the data center are often based upon the detected temperature of the cooling fluid returned into the CRAC units. In addition, the speeds of the blowers are often correlated to the operations of the cooling systems. In this respect, as the cooling systems are operated to reduce the temperature of the cooling fluid, the blowers are also operated to increase the volume flow rate of the cooled cooling fluid. Operating the cooling systems in this manner is inefficient as both the reduction in cooling fluid temperature and increase in the cooling fluid volume flow rate are typically unnecessary to maintain the components in the data center within predetermined temperature ranges.

A method for controlling one or more computer room air conditioning (CRAC) units for energy efficient operation is disclosed. In the method, the temperature of the air returned (Trat) into the one or more CRAC units and the temperature of the air supplied (Tsat) by the one or more CRAC units is detected. The caloric heat transfer level (Q) is calculated based upon the Trat and the Tsat and it is determined whether the Q is within a predetermined setpoint caloric heat transfer range. In addition, at least one operation of the one or more CRAC units is reduced in response to the Q being within the predetermined setpoint caloric heat transfer range to thereby increase the efficiencies of the one or more CRAC units.

BRIEF DESCRIPTION OF THE DRAWINGS

Features of the present invention will become apparent to those skilled in the art from the following description with reference to the figures, in which:

FIG. 1A shows a simplified plan view of a data center, according to an embodiment of the invention;

FIG. 1B shows a cross-sectional side view taken along lines IIA—IIA of FIG. 1A, according to an embodiment;

FIG. 1C shows a cross-sectional side view taken along lines IIB—IIB of FIG. 1A, according to another embodiment;

FIG. 1D shows a cross-sectional side view taken along lines IIB—IIB of FIG. 1A, according to a further embodiment;

FIGS. 2A–2C are respective block diagrams of CRAC control systems operable to control CRAC units according to various embodiments;

FIG. 3 illustrates a graph of various cooling system operating levels and the costs associated with their operations, according to an embodiment;

FIGS. 4A and 4B illustrate flow diagrams of operational modes of methods for CRAC unit control based upon setpoint temperatures and setpoint caloric heat transfer determinations, respectively, according to various embodiments; and

FIG. 5 illustrates a computer system which may be used as a platform for various operations described in the present disclosure, according to an embodiment.

DETAILED DESCRIPTION OF THE INVENTION

For simplicity and illustrative purposes, the present invention is described by referring mainly to an exemplary embodiment thereof. In the following description, numerous specific details are set forth in order to provide a thorough understanding of the present invention. It will be apparent however, to one of ordinary skill in the art, that the present invention may be practiced without limitation to these specific details. In other instances, well known methods and structures have not been described in detail so as not to unnecessarily obscure the present invention.

Throughout the present disclosure, reference is made to “cooling fluid” and “heated cooling fluid”. For purposes of simplicity, “cooling fluid” may generally be defined as air that has been cooled by a cooling device, e.g., an air conditioning unit. In addition, “heated cooling fluid” may generally be defined as cooling fluid that has been heated. It should be readily apparent, however, that the terms “cooling fluid” are not intended to denote air that only contains cooled fluid and that “heated cooling fluid” only contains cooling fluid that has been heated. Instead, embodiments of the invention may operate with air that contains a mixture of heated cooling fluid and cooling fluid. In addition, cooling fluid and heated cooling fluid may denote gases other than air, e.g., refrigerant and other types of gases known to those of ordinary skill in the art that may be used to cool electronic components.

According to an example, computer room air conditioning (CRAC) units include systems to enable energy efficient cooling and supply of cooling fluid to a data center. In addition, the systems of the CRAC units are operated in manners to generally optimize the costs associated with cooling components contained in the data center. The CRAC units may thus comprise variably controllable systems designed and operated to cool the components under substantially optimized cost structures.

In one example, the variably controllable systems include chilled fluid systems having a two-way or a three-way valve for variably controlling the flow of chilled fluid, for instance, water, refrigerant, or other coolant, etc., through a cooling coil. In another example, the variably controllable systems include variable capacity compressors designed to variably control cooling of a refrigerant configured to absorb heat from the cooling fluid received from the data center. In either of the examples above, the variably controllable systems include blowers with variable frequency drives configured to control the outputs of the cooling fluid cooled through heat transfer with the fluid contained in the cooling coil.

The variably controllable systems may be operated in manners to generally optimize their energy utilization while maintaining thermal management requirements of the com-

ponents in the data centers. In one respect, the variably controllable systems may be operated in substantially independent manners to enable the substantial optimization of energy utilization. For instance, the variably controllable systems may be operated to decrease output of cooled cooling fluid in response to a decrease in the temperature of the cooled cooling fluid. In addition, the variably controllable systems may be operated to increase output of cooled cooling fluid in response to an increase in the temperature of the cooled cooling fluid. As the energy requirements of the variably controllable systems may be minimized through these operations, the costs associated with maintaining the components within the bounds of thermal management concerns may also be substantially minimized.

With reference first to FIG. 1A, there is shown a simplified plan view of a data center **100**, according to an embodiment of the invention. The terms “data center” are generally meant to denote a room or other space and are not meant to limit the invention to any specific type of room where data is communicated or processed, nor should it be construed that use of the terms “data center” limits the invention in any respect other than its definition hereinabove.

As shown in the FIG. 1A, the data center **100** includes a plurality of racks **102**, for instance, electronics cabinets, generally positioned in substantially parallel rows. The racks **102** each house one or more components (not shown). These components may include, for instance, computers, servers, monitors, hard drives, disk drives, etc., designed to perform various operations. Some operations of the components may include, for instance, computing, switching, routing, displaying, etc. These components may comprise subsystems (not shown), for example, processors, micro-controllers, high-speed video cards, memories, semiconductor devices, and the like to perform these functions. In the performance of these electronic functions, the components, and therefore the subsystems, generally dissipate relatively large amounts of heat. Because the racks **102** have been known to include upwards of forty (40) or more subsystems, they may dissipate substantially large amounts of heat. Cooling fluid is therefore supplied to generally flow around and through the components to absorb the dissipated heat through convection, to maintain the subsystems and the components generally within predetermined operating temperature ranges.

The cooling fluid is illustrated as being supplied through vent tiles **104** in the floor **106** of the data center **100**. As will be seen in FIGS. 1B–1D, the floor **106** is a raised floor with a space therebelow. The space generally enables power lines, communication lines, and other wires (not shown), to be located below the floor **106** such that the wires and communication lines are substantially positioned away from an upper surface of the floor **106**. The space may also function as a plenum for delivery of cooling fluid from computer room air conditioner (CRAC) units **108** and **110** to the racks **102**. The vent tiles **104** are illustrated as being positioned between pairs of adjacent rows of racks **102**.

Air or other cooling fluid is received by the CRAC units **108** and **110**, cooled through heat transfer within the CRAC units **108** and **110** and supplied into the space below the floor **106**. The cooled cooling fluid is supplied from the space below the floor **106**, through the vent tiles **104** and through the racks **102** to cool the components housed in the racks **102**. The CRAC units **108** and **110** may control various characteristics of the cooling fluid supplied to the racks **102**. For instance, the CRAC units **108** and **110** may contain variably controllable systems (not shown) configured to vary the temperature of the cooling fluid supplied to the racks **102**. In

addition, the CRAC units **108** and **110** may contain systems configured to vary the volume flow rate of the cooling fluid supplied to the racks **102**. Various types of systems arranged in various configurations may be employed to control the temperature and volume flow rate of the cooling fluid. Examples of suitable components and configurations are illustrated in FIGS. 1B–1D, which are described in greater detail hereinbelow.

The aisles **116** between the racks **102** having vent tiles **104** located therebetween may be considered as cool aisles **116**. These aisles **116** are considered “cool aisles” because they are configured to receive cooling fluid from the vent tiles **104**. In addition, the racks **102** are positioned to receive cooling fluid from the cool aisles **116**. The aisles **118** between the racks **102** which do not have vent tiles **104** may be considered as hot aisles **118**. These aisles are considered “hot aisles” because they are positioned to receive cooling fluid heated by the components in the racks **102**.

Also illustrated in FIG. 1A is a computing device **112**. The computing device **112** may comprise a computer system, a controller, microprocessor, etc., configured to control operations of the CRAC units **108** and **110**. More particularly, the computing device **112** may be configured to receive input from sensors (not shown) and to vary operations of the various variable controllable systems contained in the CRAC units **108** and **110**. The computing device **112** may also be configured to receive input from a user, for instance, data center personnel, an administrator, a manager, etc. The input received from a user may comprise various set points by which the computing device **112** may determine how and when to manipulate the operations of the variable controllable systems. The computing device **112** may, in one instance, compare the conditions, for example, temperature, humidity, pressure, etc., detected by the sensors with predetermined set points for those conditions and control the variably controllable systems in response to differences between the set points and the detected conditions.

The computing device **112** is illustrated as communicating with the CRAC units **108** and **110** via wired communication lines **114**. However, it should be understood that communications between the CRAC units **108** and **110** and the computing device **112** may be effectuated through a wireless protocol, such as IEEE 802.11b, 802.11g, wireless serial connection, Bluetooth, etc., or combinations thereof, without departing from a scope of the invention. In addition, although a single computing device **112** is illustrated as controlling both CRAC units **108** and **110**, each of the CRAC units **108** and **110** may include their own computing device **112**. Moreover, the computing device **112** may comprise controllers that are integrally formed or otherwise form part of each of the CRAC units **108** and **110**. Thus, although the data center **100** has been illustrated as containing a certain configuration, it should readily be understood that various other configurations are possible for the data center **100** without departing from a scope of the invention.

The data center **100** depicted in FIG. 1A represents a generalized illustration and other components may be added or existing components may be removed or modified without departing from the scope of the invention. For example, the data center **100** may include any number of racks and various other apparatuses known to be housed in data centers. Thus, although the data center **100** is illustrated as containing four rows of racks **102**, it should be understood that the data center **100** may include any number of racks, e.g., 100 racks, without departing from the scope of the invention. The depiction of four rows of racks **102** is thus for illustrative and simplicity of description purposes only and is not intended

to limit the invention in any respect. In addition, the data center **100** may include any number of CRAC units **108** and **110**, each having a number of different types cooling systems.

The data center **100** may also include a lowered ceiling (not shown) configured with returns for receiving heated cooling fluid from within the data center **100**. The lowered ceiling may also include or form a plenum for directing the heated cooling fluid to the CRAC units **108** and **110**. An example of a data center **100** having a lowered ceiling may be found in co-pending and commonly assigned U.S. patent application Ser. No. 10/262,879, filed on Apr. 17, 2002, the disclosure of which is hereby incorporated by reference in its entirety.

In FIGS. 1B–1D, there are shown simplified partial sections of the data center **100** with three examples of the CRAC units **108**, **110**, and **110'**. FIGS. 1B–1D represent generalized illustrations and other components may be added or existing components may be removed or modified without departing from the scope of the invention. In addition, for instance, although the CRAC units **108** and **110** are illustrated as having different configurations from each other, the CRAC units **108** and **110** employed in the data center **100** illustrated in FIG. 1A may have the same type of configuration without departing from a scope of the invention.

With particular reference first to FIG. 1B, there is shown a cross-sectional side view taken along lines IIA—IIA of FIG. 1A. As shown, the CRAC unit **108** comprises a vapor-compression type air conditioning unit. More particularly, the CRAC unit **108** includes a blower **120** or a fan for delivering air or other cooling fluid into a space **122**. The space **122** may be created beneath the raised floor **106** and may include or otherwise function as a plenum. The blower **120** may also operate to draw heated cooling fluid from the data center **100** by generally forcing airflow through the CRAC unit **108**. In this regard, the CRAC unit **108** may include one or more openings to receive the heated cooling fluid from the data center **100**. A variable frequency drive (VFD) **124** is shown as being positioned adjacent to the blower **120**. The VFD **124** generally operates to control the blower **120** to vary the volume flow rate of cooling fluid flow into and out of the CRAC unit **108**.

The VFD **124** may comprise any reasonably suitable VFD that is commercially available from any number of manufacturers. The VFD **124** generally operates to variably control the speed of an alternating current (AC) induction motor. More particularly, the VFD **124** may operate to convert power from fixed voltages/variable frequencies to variable voltages/variable frequencies. By controlling the voltage/frequency levels of the blower **120**, the volume flow rate of the cooling fluid supplied by the CRAC unit **108** may also be varied.

Although the VFD **124** is illustrated as being positioned adjacent to the blower **120**, the VFD **124** may be positioned at any reasonably suitable location with respect to the blower **120** without departing from a scope of the invention. The VFD **120** may be positioned, for instance, outside of the CRAC unit **108** or various other locations with respect to the CRAC unit **108**.

In operation, the heated cooling fluid (shown as the arrow **126**) enters into the CRAC unit **108** and is cooled by operation of a cooling coil **128a**, [a compressor] a compressor **130**, [a condenser] a condenser **132**, and an expansion valve **134**, which may operate under a vapor-compression cycle. By way of example, a refrigerant, for instance, R-134a, etc.,

may be contained in a refrigerant line 136, which generally forms a loop between the various components of the cooling system containing the CRAC unit 108. More particularly, the refrigerant is supplied into the cooling coil 128a where it absorbs heat through convection from the cooling fluid received from the data center 100. The cooled cooling fluid then flows out of the CRAC unit 108 and into the space 122 as indicated by the arrow 142.

The heated refrigerant flows into the compressor 130, which compresses or pressurizes the refrigerant. The compressor 130 may comprise a variable capacity compressor or it may comprise a constant capacity compressor having a hot gas bypass (not shown). In any regard, the pressurized refrigerant then flows into the condenser 132 where some of the heat in the refrigerant is dissipated into the air around the data center 100. Although not shown, the condenser 132 may include a fan to generally enhance heat dissipation of the refrigerant. The refrigerant then flows through the expansion valve 134 and back through the cooling coil 128a. This process may be substantially continuously repeated as needed to cool the cooling fluid drawn into the CRAC unit 108. In terms of cooling system efficiency, it is generally desirable that the heated cooling fluid supplied into the CRAC unit 108 is composed of the relatively warmest portion of air in the room 100.

The cooling system illustrated in FIG. 1B has been described in a relatively simplified manner. Therefore, it should be understood that the cooling system incorporating the CRAC unit 108 may include additional components without departing from a scope of the invention. For instance, a three-way valve may be included to allow some of the refrigerant to bypass the compressor 130 and return into the cooling coil 128a. The three-way valve may be used, for instance, to divert some of the refrigerant exiting the cooling coil 128a back into the refrigerant line 136 for re-entry into the cooling coil 128 to generally ensure that the refrigerant is almost entirely in gaseous form prior to entering the compressor 130.

As described hereinabove, the computing device 112 may be configured to control various operations of the CRAC unit 108. For instance, the computing device 112 may be configured to control the operations of the compressor 130 to thereby control the temperature and flow of the refrigerant flowing through the cooling coil 128a. The computing device 112 may also be configured to control the VFD 124. More particularly, the computing device 112 may control the motor speed of a blower 122 to thereby control the volume flow rate of the cooled cooling fluid supplied by the CRAC unit 108. By controlling the temperature of the refrigerant and the airflow rate through the CRAC unit 108, the computing device 112 is generally capable of controlling the level of heat transfer between the heated cooling fluid and the refrigerant to thereby control the temperature of the cooling fluid supplied into the data center 100.

According to an example, the computing device 112 is configured to substantially independently control the compressor 130 and the VFD 124. The computing device 112 may be configured to determine manners in which to control the compressor 130 and the VFD 124 based upon, for instance, environmental condition measurements obtained by sensors 138 and 140. As shown in FIG. 1B, the sensor 138 is positioned at an inlet of the CRAC unit 108 and is thus configured to measure one or more conditions of the cooling fluid returning to the CRAC unit 108.

In addition, the sensor 140 is positioned at an outlet of the CRAC unit 108 and is thus configured to measure one or

more conditions of the cooling fluid supplied by the CRAC unit 108. Alternatively, the sensor 140 may be positioned at an inlet of a rack 102 or near a vent tile 104, provided that the rack 102 or the vent tile 104 is located within a relatively close proximity to the exhaust of CRAC unit 108. More particularly, the sensor 140 may be positioned at a location substantially downstream of the CRAC unit 108 where the temperature of the cooling fluid supplied by the CRAC unit 108 does not vary beyond a certain level from the time the cooling fluid exits the CRAC unit 108. In one respect, the computing device 112 may be configured to control the compressor 130 and the VFD 124 to substantially minimize energy usage by the CRAC unit 110 as will be described in greater detail hereinbelow.

With reference now to FIG. 1C, there is shown a cross-sectional side view taken along lines IIB—IIB of FIG. 1A. As shown, the CRAC unit 110 comprises a chiller type air conditioning unit. More particularly, the CRAC unit 110 includes a blower 120 or a fan for delivering air or other cooling fluid into a space 122. As described hereinabove with respect to FIG. 1B, the space 122 may be created beneath the raised floor 106 and may include or otherwise function as a plenum. The blower 120 may also operate to draw heated cooling fluid from the data center 100 by generally forcing airflow through the CRAC unit 110. In this regard, the CRAC unit 110 may include one or more openings to receive the heated cooling fluid from the data center 100. A variable frequency drive (VFD) 124 is shown as being positioned adjacent to the blower 120. The VFD 124 generally operates to control the blower 120 to vary the volume flow rate of cooling fluid flow into and out of the CRAC unit 110 as described hereinabove.

The arrow 126 indicates the heated cooling fluid received by the CRAC unit 110. The heated cooling fluid flows past a cooling coil 128b and exchanges heat with a coolant contained in the cooling coil 128b. The coolant may comprise water or other fluid capable of being heated and cooled in a repeated manner. The speed at which the heated cooling fluid flows past the cooling coil 128b and the temperature of the coolant contained in the cooling coil 128b generally affect the temperature of the cooling fluid. Thus, for instance, as the temperature of the coolant decreases with the blower 120 operating at a constant level, so too does the temperature of the cooling fluid. The cooled cooling fluid then flows out of the CRAC unit 110 and into the space 122 as indicated by the arrow 142.

The temperature of the coolant contained in the cooling coil 128b may be controlled through operation of a cooling system comprising the CRAC unit 110. In operation, the coolant receives heat from the cooling fluid received into the CRAC unit 110. The heat transfer from the cooling fluid into the coolant in the cooling coil 128b may be effectuated through convection. The heated coolant then flows out of the cooling coil 128b and into a first coolant line 144a. The heated coolant flows through the first coolant line 144a and into a heat exchanger 146 which may also include a coil 148. The heated coolant is cooled through heat transfer with a refrigeration circuit 150, which includes an evaporator 152, a compressor 154, a condenser 156 and an expansion valve 158. The refrigeration circuit 150 may operate under a vapor-compression cycle generally known to those of ordinary skill in the art.

The cooled coolant returns toward the cooling coil 128b through a second coolant line 144b. A three-way valve 160 is provided generally upstream from the cooling coil 128b along the second coolant line 144b. The three-way valve 160 generally operates to control the amount of cooled coolant

supplied into the cooling coil **128b**. The three-way valve **160** may control the cooled coolant delivery into the cooling coil **128b** by diverting some or all of the cooled coolant back into the first coolant line **144a** through a third coolant line **144c**, thereby bypassing the cooling coil **128b**. The three-way valve **160** may thus substantially control the temperature of the coolant delivered into the cooling coil **128b** by controlling the amount of cooled coolant delivered into the cooling coil **128b**. In one respect, therefore, the three-way valve **160** may also control the temperature of the cooling fluid supplied into the space **122**.

A pump **162** is illustrated as being located along the first coolant line **144a**. The pump **162**, however, may be positioned along the second coolant line **144b** without departing from a scope of the invention. The pump **162** generally operates to pressurize the coolant contained in the coolant lines **144a–144c**, such that the coolant may flow along the circuit created by the coolant lines **144a–144c**. The pump **162** may be controlled in addition to or in place of the three-way valve **160** to enable reduced energy usage. In one regard, because the pump **162** may be operated to vary the flow rate of the coolant in the coolant lines **144a–144c**, the pump **162** operations may be reduced, for instance, commensurate with increases in the cooling fluid temperature. In addition, a valve configured to enable a substantially constant and predictable coolant flow in the coolant lines **144a** and **144b** may be positioned upstream of the pump **162**. The valve may include a spring-loaded valve configured to deliver constant flow for certain pressure ranges. A suitable valve may be available from GRISWOLD CONTROLS of Irvine, Calif.

In operation, the temperature of the coolant contained in the coolant lines **144a–144c** generally dictates the amount of energy consumed in operating the CRAC unit **110**. More particularly, the refrigeration circuit **150** generally requires less energy when the temperature of the coolant entering into the heat exchanger **146** is lower. In contrast, the refrigeration circuit **150** generally consumes greater amounts of energy when the temperature of the coolant entering into the heat exchanger **146** is higher. In addition, the desired temperature of the coolant supplied from the heat exchanger **146** also generally dictates the amount of energy consumed by the refrigeration circuit **150**. That is, the more work required by the refrigeration circuit **150** in reducing the temperature of the coolant, the greater the energy consumption.

In one example, the refrigeration circuit **150** is operated to cool the coolant to substantially the highest temperature where the three-way valve **160** may remain in a generally fully open position to thus cause substantially all of the coolant to flow into the cooling coil **128b**. In this regard, the energy consumed by the refrigeration circuit **150** may be substantially minimized as relatively no coolant is diverted away from the cooling coil **128b**. Moreover, energy consumption of the refrigeration circuit **150** may be lower because the temperature of the refrigerant contained in the refrigeration circuit **150** may be higher and because coolant at higher temperatures generally gains less energy from its surroundings. When multiple CRAC units **110** are employed to cool the components in a data center **100**, at least one of the CRAC units **110** may be operated in this manner to thereby reduce energy usage of the at least one of the CRAC units **110**.

The computing device **112** is configured to substantially independently control the three-way valve **160** and the VFD **124** to thereby control the temperature of the cooling fluid and the volume flow rate of the supplied cooling fluid. The computing device **112** may be configured to determine manners in which to control the three-way valve **160** and the

VFD **124** based upon, for instance, environmental condition measurements obtained by the sensors **138** and **140**. In one respect, the computing device **112** may be configured to control the three-way valve **160** and the VFD **124** to substantially minimize energy usage by the CRAC unit **110** as will be described in greater detail hereinbelow.

Although reference is made in FIGS. **1B** and **1C** to the use of a blower **120** to draw heated cooling fluid from the data center **100**, it should be understood that any other reasonably suitable manner of cooling fluid removal from the data center **100** may be implemented without departing from the scope of the invention. By way of example, a separate fan or blower (not shown) may be employed to draw heated cooling fluid from the data center **100**. In addition, the CRAC units **108** and **110** may include a humidifier and/or a dehumidifier as is known to those of ordinary skill in the art.

In addition, one or more isolation valves (not shown) may be placed at various locations along the coolant lines **144a–144c** to thereby enable, for instance, preventative maintenance.

FIG. **1D** depicts a cross-sectional side view taken along lines IIB—IIB of FIG. **1A**, according to another example. In FIG. **1D**, there is shown a CRAC unit **110'**. The CRAC unit **110'** includes all of the components illustrated in FIG. **1C** and thus specific reference to those components are not reiterated. Instead, only those elements depicted in FIG. **1D**, which differ from the components depicted in FIG. **1C** are discussed hereinbelow.

The major difference between the CRAC unit **110** and the CRAC unit **110'** is that the CRAC unit **110'** includes a two-way valve **164** in place of the three-way valve **160**. In addition, the CRAC unit **110'** does not include the third coolant line **144c** illustrated in FIG. **1C**. The CRAC unit **110'** also includes a mass flow sensor **166** positioned along the first coolant line **144a**. The mass flow sensor **166** is configured to detect the mass flow rate of the fluid flowing through the first coolant line **144a**. The mass flow sensor **166** may be required in the CRAC unit **110'** since the two-way valve **164** does not enable constant coolant flow through the coolant lines **144a** and **144b**, as is the case with the three-way valve **160** of the CRAC unit **110**. In addition, with use of the two-way valve **164**, the valve orifice opening in the two-way valve **164** may require calibration.

The pump **162** may be controlled in addition to or in place of the two-way valve **164** to enable reduced energy usage. In one regard, because the pump **162** may be operated to vary the flow rate of the coolant in the coolant lines **144a–144c**, the pump **162** operations may be reduced, for instance, commensurate with increases in the cooling fluid temperature.

In addition, the temperature of the coolant supplied from the heat exchanger **146** also generally dictates the amount of energy consumed by the refrigeration circuit **150**. That is, the more work required by the refrigeration circuit **150** in reducing the temperature of the coolant, the greater the energy consumption. In one example, the refrigeration circuit **150** is operated to cool the coolant to substantially the highest temperature where the two-way valve **164** may remain in a generally fully open position to thus cause substantially all of the coolant to flow into the cooling coil **128b**. The energy consumed by the refrigeration circuit **150** may be lower because the temperature of the refrigerant contained in the refrigeration circuit **150** may be higher and because coolant at higher temperatures generally gains less energy from its surroundings. When multiple CRAC units **110** are employed to cool the components in a data center **100**, at least one of the CRAC units **110** may be operated in

this manner to thereby reduce energy usage of the at least one of the CRAC units **110**.

FIGS. 2A–2C are respective block diagrams **200**, **250**, and **250'** of CRAC control systems **202**, **252**, and **252'** operable to control the CRAC units **108**, **110** and **110'**. The following descriptions of the block diagrams **200**, **250**, **250'** are some manners of a variety of different manners in which such CRAC control systems **202**, **252**, **252'** may be configured. In addition, it should be understood that the block diagrams **200**, **250**, **250'** may include additional components and that some of the components described herein may be removed and/or modified without departing from the scope the invention.

With reference first to FIG 2A, the CRAC control system **202** includes a controller **204** for controlling operations of the CRAC control system **202**. The controller **204** may comprise the computing device **112** and thus may also comprise a microprocessor, a micro-controller, an application specific integrated circuit (ASIC), and the like. The controller **204** is generally configured to receive temperature measurements from an inlet temperature sensor **138**, an outlet temperature sensor **140** and an optional power meter **206**.

As described hereinabove, the inlet temperature sensor **138** generally operates to detect the temperature of the heated cooling fluid received by the CRAC unit **108**. In addition, the outlet temperature sensor **140** is configured to detect the temperature of the cooled cooling fluid supplied by the CRAC unit **108**. In a general sense, the controller **204** may determine manners in which to control the CRAC unit **108** based substantially upon the temperatures detected by the temperature sensors **138** and **140**.

Communications between the sensors **138** and **140** and the controller **204** may be effectuated through, for instance, an Ethernet-type connection or through a wired protocol, such as IEEE 802.3, etc., or wireless protocols, such as IEEE 802.11b, 802.11g, wireless serial connection, Bluetooth, etc., or combinations thereof.

The temperature information received from the temperature sensors **138** and **140** may be stored in a memory **208**. In addition, various control schemes for operating the CRAC unit **108** may be stored in the memory **208**. In this regard, the memory **208** may comprise a traditional memory device, such as, volatile or non-volatile memory, such as DRAM, EEPROM, flash memory, combinations thereof, and the like. The controller **204** may thus access information stored in the memory **208** to determine the manners in which the CRAC unit **108** may be operated.

The optional power meter **206** may detect the power consumption of the CRAC unit **108** and thus may be positioned or otherwise configured to measure the power consumption of the CRAC unit **108**. The power member **206** may comprise any reasonably suitable, and commercially available power meter capable of measuring the CRAC unit **108** power consumption. The controller **204** may receive the detected power consumption and may also store this information in the memory **208**. The power meter **206** is considered as being optional because the controller **204** may be configured to calculate the CRAC unit **108** power consumption based upon operations of the various components, for instance, compressor **130**, blower **120**, etc. As an example, the controller **204** may be configured to determine the power consumption of the compressor **130** based upon its current operating load. A correlation between the power consumption levels and the operating loads of the compressor **130** may be employed to make this determination.

With reference now to FIG. 2B, the CRAC control system **252** includes similar components to those described herein-

above with respect to the CRAC control system **202**. Therefore, only those components that differ from the elements described hereinabove with respect to the CRAC control system **202** will be described. More particularly, the CRAC control system **252** includes the CRAC unit **110** instead of the CRAC unit **108**. In this regard, the CRAC control system **252** is configured to control the three-way valve **160** to vary the temperature of the cooling fluid supplied to the data center **100**.

As an example, the controller **204** may operate to control the three-way valve **160** and the blower **120** in manners to substantially minimize the power consumption of the CRAC unit **110** while maintaining the temperature of the cooling fluid supplied by the CRAC unit **110** within the threshold setpoint temperature range. The controller **204** may thus determine various operating conditions for the three-way valve **160** and the blower **120** to substantially minimize the power consumptions associated with their operations. Although reference is made throughout the present disclosure to the control of the blower **120**, the controller **204** may control the VFD **124** to thereby control the blower **120** speed.

As depicted in FIG. 2C, the CRAC control system **252'** include similar components to those described hereinabove with respect to the CRAC control system **202** and **252**. Therefore, only those components that differ from the elements described hereinabove with respect to those CRAC control systems **202** and **252** will be described. As shown, the CRAC control system **252'** includes the CRAC unit **110'** instead of the CRAC units **108** and **110**. In this regard, the CRAC control system **252'** is configured to control the two-way valve **164** to vary the temperature of a coolant and therefore vary the temperature of the cooling fluid supplied by the CRAC unit **110'**.

In addition, the controller **204** may control the blower **120** to control the volume flow rate of the cooling fluid supplied by the CRAC unit **110'**. In this regard, the controller **204** may control the temperature and the volume flow rate of the cooling fluid supplied by the CRAC unit **110'** in manners to substantially minimize the power consumption of the CRAC unit **110'** while maintaining the temperature of the cooling fluid supplied by the CRAC unit **110** within the threshold setpoint temperature range. The controller **204** may thus determine various operating conditions for the two-way valve **164** and the blower **120** to substantially minimize the power consumptions associated with their operations.

In each of the CRAC control systems **202**, **252**, **252'**, the controller **204** may be configured to receive input from a user, for instance, a technician, an administrator, etc. As described in greater detail hereinbelow, the controller **204** may include one or more input devices, for instance, keyboard, mouse, disk drives, etc., for receiving input from the user. The input may, for instance, be in the form of predetermined operating set points for the CRAC units **108**, **110**, **110'**. By way of example, a user may input a setpoint temperature (Tset) range into the controller **204**. The setpoint temperature (Tset) range may be based upon desired heat removal characteristics in the data center **100**. In one respect, the setpoint temperature (Tset) range may comprise temperatures that ensure safe operating conditions for the components housed in the data center **100**. The safe operating conditions for the components may be based upon the specifications provided by the component manufacturers. Alternatively, the safe operating conditions may be determined through testing of the components or through historical data. For instance, the components may be operated at various temperatures to determine at which temperatures the

performance characteristics of the components being to decline or when the components begin to fail.

A maximum setpoint temperature (Tset,max) of the setpoint temperature (Tset) range may constitute an upper limit of safe operating conditions for the components. In other words, if the heated cooling fluid returning to the CRAC units **108, 110, 110'** is above the maximum setpoint temperature (Tset,max), it may be determined that the temperature of the components may be beyond the safe operating conditions. As another example, a minimum setpoint temperature (Tmin,set) of the setpoint temperature (Tset) range may constitute a lower limit indicating a temperature at which operations of the CRAC units **108, 110, 110'** may be ceased. In addition, the controller **204** may store the inputted threshold setpoint temperature (Tset) range in the memory **208**.

In addition, the controller **204** may utilize the information received from one or both of the sensors **138, 140**, the power meter **206**, and the user received input, to determine manners in which to operate the compressor **130**, the three-way valve **160**, or the two-way valve **164**, and the blower **120** of the CRAC unit **108**. In one example, the controller **204** may operate the compressor **130**, three-way valve **160**, or the two-way valve **164**, and the blower **120** to substantially minimize power consumption of the respective CRAC units **108, 110, 110'** while maintaining the temperature of heated cooling fluid returned to the CRAC units **108, 110, 110'** within the setpoint temperature (Tset) range. Thus, for instance, the controller **204** may manipulate the compressor **130**, the three-way valve **160**, or the two-way valve **164**, and the blower **120** operations to various levels so long as the temperature of the heated cooling fluid returned to the CRAC units **108, 110, 110'** remains within the setpoint temperature (Tset) range.

As another example, the controller **204** may determine manners in which to operate the compressor **130**, the three-way valve **160**, or the two-way valve **164**, and the blower **120** based upon the loading of the CRAC unit **108**. In this instance, the controller **204** may be configured to calculate the caloric heat transfer from the heated cooling fluid to the refrigerant of the CRAC units **108, 110, 110'**. The caloric heat transfer (Q) may be calculated from the following equation:

$$Q = mC_p(T_{out} - T_{in}) \quad \text{Equation (1)}$$

where m is the mass flow rate of the cooling fluid, C_p is the heat capacity of the cooling fluid, T_{out} is the temperature of the cooled cooling fluid supplied and T_{in} is the temperature of the heated cooling fluid received by the CRAC units **108, 110, 110'**.

According to this example, a setpoint caloric heat transfer (Qset) range may be used in place of the setpoint temperature (Tset) range. Thus, for instance, the controller **204** may be configured to substantially minimize the power consumptions of the CRAC units **108, 110, 110'** by varying operations of the compressor **130**, the three-way valve **160**, or the two-way valve **164**, and the blower **120** so long as the caloric heat transfer (Q) is within the setpoint caloric heat transfer (Qset) range. In one respect, the caloric heat transfer (Qset) range may comprise heat transfer rates that ensure safe operating conditions for the components housed in the data center **100**. The safe operating conditions for the components may be based upon the specifications provided by the component manufacturers. Alternatively, the safe operating conditions may be determined through testing of the components or through historical data. For instance, the components may be operated at various temperatures to determine at which tem-

peratures the performance characteristics of the components being to decline or when the components begin to fail.

In similar fashion to those manners described hereinabove, if the calculated caloric heat transfer (Q) is above a maximum setpoint caloric heat transfer level (Qset,max), the components in the data center **100** may be insufficiently cooled. In addition, if the calculated caloric heat transfer (Q) is below a minimum setpoint caloric heat transfer level (Qset,min), operations of the CRAC units **108, 110, 110'** may be ceased as the CRAC unit **108** may be drawing power unnecessarily.

In operation, the controllers **204** of the CRAC control systems **202, 252, 252'** may determine the compressor **130**, three-way valve **160**, or the two-way valve **164**, and the blower **120** operations to substantially minimize CRAC unit **108, 110, 110'** power consumptions when the temperatures of the heated cooling fluid returned to the CRAC units **108, 110, 110'** are within the setpoint temperature (Tset) range. In addition, operations of these systems may be varied when the caloric heat transfer is within the setpoint caloric heat transfer (Qset) range. More particularly, the controllers **204** may determine which combinations of compressor **130**, three-way valve **160**, or two-way valve **164**, and blower **120** operations substantially minimize CRAC unit **108, 110, 110'** power consumption levels when the temperatures of the cooling fluid received from the components are within an acceptable range.

Thus, for instance, if the temperatures of the cooling fluid supplied from the components are acceptable, the controllers **204** may select operating levels of the compressor **130**, the three-way valve **160**, or the two-way valve **164**, and the blower **120** that substantially minimize the costs associated with their operations. These operating levels and costs may be considered in terms of the graph **300** illustrated in FIG. 3. In the graph **300**, there is illustrated two x-axes **302** and **304** and a y-axis **306**. The first x-axis **302** denotes the speed of the blower **120** and the second x-axis **304** denotes the temperature of the cooling fluid (Tcf,out) supplied by the respective CRAC units **108, 110, 110'**. The y-axis **306** denotes the energy consumptions and thus the costs associated with various cooling fluid temperatures (i.e., compressor **130**, three-way valve **160**, or two-way valve **164**, operations) and blower **120** speeds.

The power consumption levels or costs associated with operating the compressor **130**, the three-way valve **160**, or the two-way valve **164**, and the blower **120** at various levels may be based upon manufacturer provided specifications. In addition, or alternatively, the power consumption levels or costs may be determined through testing. In terms of testing, for instance, the power meter **206** may be used to measure the power draws of the compressor **130**, the refrigeration circuit **150** (under various three-way valve **160** and the two-way valve **164** settings), and the blower **120** at different levels of operation. The correlations between the power consumption levels or costs and the operating levels of the compressor **130**, the refrigeration circuit **150**, and the blower **120** may be stored in the memory **208**. This information may be stored in the form of, for instance, a look-up table, or through other searchable means.

As shown in the graph **300**, the energy consumption level of the compressor **130** (or a refrigeration circuit **150** in the case of the CRAC units **110, 110'**, decreases as the temperature of the cooling fluid (Tcf,out) supplied by the CRAC unit **108** decreases at constant CRAC unit loading. In addition, the energy consumption level of the blower **120** increases as the speed of the blower **120** increases. Thus, the controllers **204** of the CRAC units **108, 110, 110'** may be configured to

vary the operations of the compressor **130**, the three-way valve **160**, or the two-way valve **164**, and the blower **120** such that they consume the least amount of power while maintaining the temperatures of the cooling fluid returned into the CRAC units **108**, **110**, **110'** within the setpoint temperature ranges.

FIGS. **4A** and **4B** illustrate flow diagrams of operational modes **400** and **450** of methods for CRAC unit control based upon setpoint temperatures and setpoint caloric heat transfer determinations, respectively. It is to be understood that the following descriptions of the operational modes **400** and **450** are two manners of a variety of different manners in which CRAC unit control may be effectuated. It should also be apparent to those of ordinary skill in the art that the operational modes **400** and **450** represent generalized illustrations and that other steps may be added or existing steps may be removed, modified or rearranged without departing from a scope of the invention.

The descriptions of the operational modes **400** and **450** are made with reference to the block diagrams **200**, **250**, **250'** illustrated in FIGS. **2A–2C**, respectively, and thus makes reference to the elements cited therein. It should, however, be understood that the operational modes **400** and **450** are not limited to the elements set forth in the block diagrams **200**, **250**, **250'**. Instead, it should be understood that the operational modes **400** and **450** may be practiced by CRAC unit control systems having a different configuration than those set forth in the block diagrams **200**, **250**, **250'**.

The operational modes **400** and **450** may be initiated or started at steps **402** and **452**, respectively, for instance, by activating one or more CRAC units **108**, **110**, **110'**, activating one or more components in the data center **100**, etc. In addition, or alternatively, the operational mode **400** may be manually initiated, after a predetermined period of time, etc. It is to be understood that either or both of the operational modes **400** and **450** may be performed depending upon the configuration of the CRAC units **108**, **110**, **110'**. For instance, those CRAC units **108**, **110**, **110'** configured to operate based upon setpoint temperatures, may perform the operational mode **400**, whereas those CRAC units **108**, **110**, **110'** configured to operate based upon setpoint caloric heats may perform the operation mode **450**. Additionally, performance of either operational mode **400** and **450** may be user-specified.

With reference first to the operational mode **400** of FIG. **4A**, the controllers **204** of one or more of the CRAC control systems **200**, **250**, **250'** may receive a setpoint temperature (Tset) range as indicated at step **404**. The setpoint temperature (Tset) range may be supplied by the CRAC manufacturers or they may user-specified and inputted into the computing device **112** through any known input means. Step **404**, however, may be omitted for situations in which the controllers **204**, for instance, have previously received the setpoint temperature (Tset) range.

At step **406**, one or more of the sensors **138** may detect the temperatures of the return air (Trat). A comparison of the detected return air temperatures (Trat) and the setpoint temperature (Tset) range may be made at step **408**. More particularly, at step **408**, it may be determined whether the temperatures of the heated cooling fluid returning into the CRAC units **108**, **110**, **110'** are within the setpoint temperature (Tset) range. For those CRAC units **108**, **110**, **110'** having detected return air temperatures (Trat) outside of the setpoint temperature (Tset) range, the controllers **204** of those CRAC units **108**, **110**, **110'** may determine whether the detected return air temperatures (Trat) are below minimum setpoint temperature levels (Tset,min), at step **410**. The

minimum setpoint temperature levels (Tset,min) for the CRAC units **108**, **110**, **110'** may be the same for each of the CRAC units **108**, **110**, **110'** or they may vary for each of the CRAC units **108**, **110**, **110'**. In this regard, for instance, each of the CRAC units **108**, **110**, **110'** may be operated in substantially independent manners.

At step **410**, for those CRAC units **108**, **110**, **110'** having detected return air temperatures (Trat) are not below the minimum set point temperature levels (Tset,min), the detected return air temperatures (Trat) are considered as being above maximum setpoint temperature levels (Tset, max), since they are outside of the setpoint temperature (Tset) ranges. The controllers **204** of those CRAC units **108**, **110**, **110'** may therefore decrease the temperature and/or increase the volume flow rate of cooling fluid supplied to the data center **100**, as indicated at step **412**. The decreased temperature and/or the increased cooling fluid volume flow rate may be required to bring the detected return air temperatures (Trat) within the maximum setpoint temperature levels (Tset,max).

Additionally, at step **412**, the controllers **204** of those CRAC units **108**, **110**, **110'** may decrease the temperature of the refrigerant/coolant and/or increase the volume flow rate of cooling fluid supplied based upon the costs associated with each action. For instance, if the costs associated with decreasing the temperature of the refrigerant/coolant is relatively less than increasing the volume flow rate, the controllers **204** may cause the refrigerant/coolant temperature to be decreased while maintaining the volume flow rate level. As another example, if the controllers **204** determine that a combination of actions are associated with the lowest costs, the controllers **204** may find substantially optimum combinations of actions to achieve the desired results at the lowest costs.

As another example, at step **412**, the controllers **204** of those CRAC units **108**, **110**, **110'** may decrease the temperature of the refrigerant/coolant and/or increase the volume flow rate of cooling fluid supplied based upon the known effectiveness of each action. Thus, for instance, the controllers **204** may have access to historical data indicating the effects of the various actions taken by the CRAC units **108**, **110**, **110'**. By way of example, if it is determined that reducing the refrigerant/coolant temperature to a certain level requires X amount of energy and increasing the volume flow rate to another certain level requires the same amount of energy, and increasing the volume flow rate is more effective, the controllers **204** may decide to increase the volume flow rate as this action is more efficient.

At step **410**, for those CRAC units **108**, **110**, **110'** having detected return air temperatures (Trat) that are below the minimum set point temperature level (Tset,min), those CRAC units **108**, **110**, **110'** may enter a sleep mode as indicated at step **414**. The sleep mode may include a powered down mode in which the CRAC units **108**, **110**, **110'** draw reduced amounts of power as compared to when the CRAC units **108**, **110**, **110'** are fully operational. The reduced amounts of power may comprise power states that are somewhere between the fully operational mode and a completely shut down mode. In addition, the sleep mode may constitute a power saving mode in which the CRAC units **108**, **110**, **110'** may be reactivated or otherwise brought back to fully operational status in a relatively short period of time. The reduced power state of the CRAC units **108**, **110**, **110'** may vary for differing types of CRAC units.

In any regard, the sleep mode may include a mode in which the power supply to the temperature sensor **138** positioned to detect the temperature of the cooling fluid around

the inlet of the CRAC unit **108, 110, 110'**, remains active. In addition, the sleep mode may also include the supply of a small amount of power to enable the blower to substantially continuously cause a relatively small amount of cooling fluid flow through the CRAC units **108, 110, 110'**. In this regard, the temperatures of the cooling fluid supplied into the CRAC units **108, 110, 110'** may be substantially continuously monitored when the CRAC units **108, 110, 110'** are in the sleep mode.

The CRAC units **108, 110, 110'** may exit from the sleep mode, for instance, when the detected return air temperature (Trat) exceeds the maximum setpoint temperature (Tset, max), as indicated at step **412**. Alternatively, the CRAC units **108, 110, 110'** may be configured to exit from the sleep mode when the return air temperature (Trat) exceeds another predefined temperature, which may be defined according to, for instance, operating requirements of the components to which the CRAC units **108, 110, 110'** delivers cooling fluid. As another alternative, the CRAC units **108, 110, 110'** may exit the sleep mode after a predetermined period of time, manually revived, in response to receipt of a setpoint temperature range, etc.

In another example, a plurality of CRAC units **108, 110, 110'** may be networked or otherwise configured to communicate with one another. For instance, the same controller **204** may control the plurality of CRAC units **108, 110, 110'**. In any regard, the controllers **204** of the CRAC units **108, 110, 110'** may be configured to communicate their statuses to the other CRAC units **108, 110, 110'**. The statuses of the CRAC units **108, 110, 110'** may be used by the controllers **204** to determine the provisioning levels of the CRAC units **108, 110, 110'**. By way of example, if one of the CRAC units **108, 110, 110'** is in the sleep mode and the provisioning level of a neighboring CRAC unit **108, 110, 110'** is too high, for instance, the return air temperature (Trat) into the neighboring CRAC unit **108, 110, 110'** is above a predefined level, the CRAC unit **108, 110, 110'** may be brought out of the sleep mode. In this instance, the return air temperature (Trat) may not need to be measured during the sleep mode thereby enabling that CRAC unit **108, 110, 110'** to draw less power when in the sleep mode.

With reference back to step **408**, for those CRAC units **108, 110, 110'** having return air temperatures (Trat) within the setpoint temperature (Tset) range, the controllers **204** of those CRAC units **108, 110, 110'** may determine the power consumption of the respective cooling systems at step **416**. The cooling systems may comprise, for instance, the compressor **130** in FIG. **1B** or the refrigeration circuits **150** in FIGS. **1C** and **1D**. The controllers **204** may also determine the power consumptions of the blowers **120** at step **418**.

The power meter **206** may be employed to determine the power consumptions of the cooling system components. Alternatively, the power consumption may be calculated based upon operations of the various components, for instance, the compressor **130**, the blower **120**, etc. As an example, the controllers **204** may be configured to determine the power consumption of the compressor **130** based upon its current operating load. A correlation between the power consumption levels and the operating loads of the compressor **130** may be employed to make this determination.

At step **420**, the power consumptions of the cooling systems and the blower **120** may be correlated to a cost function. For instance, the costs associated with the power consumed by the cooling systems and the blower **120** may be determined. In addition, the power consumed by the cooling systems and the blower **120** may be utilized in determining the operations of the cooling systems and the blower **120**.

The power consumptions of the cooling systems may include a determination of the conditions external to the condenser **132** or refrigeration circuit **150**. That is, for instance, the costs incurred by the cooling systems may vary according to the external conditions. For instance, if ambient conditions are relatively hot and/or humid, greater amounts of energy may be expended by the cooling systems to enable sufficient heat transfer between the refrigerant and/or coolant to thereby maintain the refrigerant and/or coolant at desired temperatures.

At step **422**, the controllers **204** may determine whether the costs may be reduced. The controllers **204** may ascertain whether costs may be reduced through, for instance, a determination of the output requirements of the CRAC units **108, 110, 110'** to substantially maintain the cooling fluid temperature and delivery to the components in the data center within the setpoint temperature ranges.

If the costs cannot be reduced, that is, the controllers **204** determine that the CRAC units **108, 110, 110'** are operating at or near optimum energy levels, the controllers **204** may not vary the cooling system operations and the operational mode **400** may be continued, for instance, at step **406**. However, if the controllers **204** determine that costs may be reduced, the controllers **204** may determine a scheme to enable the costs associated with operating the cooling systems to be reduced at step **424**. The controllers **204** may determine how costs may be reduced based upon the costs associated with increasing refrigerant/coolant temperature and/or decreasing the volume flow rate of the cooling fluid supplied. For instance, if the cost savings associated with increasing the temperature of the refrigerant/coolant is relatively higher than the cost savings associated with decreasing the volume flow rate, the controllers **204** may cause the refrigerant/coolant temperature to be increased while maintaining the volume flow rate level. In the alternative, if the cost savings associated with decreasing the volume flow rate is relatively higher than the cost savings associated with increasing the refrigerant/coolant temperature, the controllers **204** may cause the volume flow rate to be decreased while maintaining the refrigerant/coolant temperature level. As another example, if the controllers **204** determine that a combination of actions produces the greatest cost savings, the controllers **204** may find substantially optimum combinations of actions to achieve the desired results at the greatest cost savings.

At step **426**, the controllers **204** may implement the reduced cost scheme determined at step **424**. The reduced cost scheme may be implemented according to an iterative process or it may implemented according to historical data. If an iterative process is implemented, the controllers **204** may cause either or both of the cooling fluid temperature to the increased and the volume flow rate to the decreased incrementally until the CRAC units **108, 110, 110'** are operating at or near optimal levels. If historical data is relied upon, the controllers **204** may know how to manipulate the CRAC units **108, 110, 110'** based upon previously performed manipulations to reach the substantially optimal performance levels.

In addition, the operational mode **400** may be continued to thereby enable substantially continuous monitoring and control over the CRAC units **108, 110, 110'**. In one respect, operations of the CRAC units **108, 110, 110'** may be substantially continuously altered to enable energy and cost savings.

With reference now to the operational mode **450** of FIG. **4B**, the controllers **204** of one or more of the CRAC control systems **200, 250, 250'** may receive a setpoint caloric heat

transfer (Qset) range at step 454. The caloric heat transfer (Q) of a CRAC unit 108, 110, 110' may be used to determine the workload on the CRAC unit 108, 110, 110' and may be determined through Equation (1) recited hereinabove. In this regard, and as described in greater detail hereinbelow, if the caloric heat transfer (Q) of a CRAC unit 108, 110, 110' is within a predefined range, operations of the compressor 130, the three-way valve 160, or the two-way valve 164 may be varied to substantially minimize their energy consumptions. It should be appreciated that step 454 may be omitted for situations in which the controllers 204, for instance, have previously received the setpoint caloric heat transfer (Qset) range.

At step 456, one or more of the sensors 138 may detect the temperatures of the return air (Trat) and one or more of the sensors 140 may detect the temperatures of the supply air (Tsat) at step 458. At step 460, the controllers 204 may calculate the caloric heat transfer rates (Q). In addition, the controllers 204 may determine whether the calculated caloric heat transfer rates (Q) are within the setpoint caloric heat transfer (Qset) range at step 462.

For those CRAC units 108, 110, 110' having calculated caloric heat transfer rates (Q) that are within the Qset range, steps 416-426 set forth in the box A of FIG. 4A may be performed at step 464. However, for those CRAC units 108, 110, 110' having calculated caloric heat transfer rates (Q) that are outside of the Qset range, the controllers 204 of those CRAC units 108, 110, 110' may determine whether the calculated caloric heat transfer rates (Q) are below minimum setpoint caloric heat transfer levels (Qset,min) at step 466. The Qset,min for the CRAC units 108, 110, 110' may be the same for each of the CRAC units 108, 110, 110' or they may vary for each of the CRAC units 108, 110, 110'. In this regard, for instance, each of the CRAC units 108, 110, 110' may be operated in substantially independent manners.

At step 466, for those CRAC units 108, 110, 110' having calculated caloric heat transfer rates (Q) are not below the minimum set point caloric heat transfer levels (Qset,min), the calculated caloric heat transfer rates (Q) are considered as being above maximum setpoint caloric heat transfer levels (Qset,max), since they are outside of the setpoint caloric heat transfer (Qset) ranges. The controllers 204 of those CRAC units 108, 110, 110' may determine whether the flow rates (FR) of the cooling fluid supplied by those CRAC units 108, 110, 110' are below a flow rate set point (FRset). The flow rate (FR) of the cooling fluid supplied by the CRAC units 108, 110, 110' may be detected through use of, for instance, an anemometer. In addition, or alternatively, the flow rate (FR) may be determined based upon the speed of the VFD. In any regard, the flow rate set point (FRset) may be based upon, for instance, historical data that indicates, for instance, a flow rate of cooling fluid supplied by the CRAC units 108, 110, 110' are optimal for a given CRAC unit 108, 110, 110'. The optimum flow rates may be based, for instance, on the configuration and airflow patterns of the areas in which the CRAC units 108, 110, 110' are configured to deliver the cooling fluid. In this regard, the flow rate setpoints may vary for each of the CRAC units 108, 110, 110' and may also vary as airflow patterns change.

If it is determined at step 468 that the flow rate (FR) exceeds the flow rate setpoint (FRset), the flow rate may not be varied. If, however, it is determined that the flow rate (FR) does not exceed the flow rate setpoint (FRset), the volume flow rate of the CRAC unit 108, 110, 110' may be increased as indicated at step 470. The level of increase in the volume flow rate may be based upon various factors. For instance, the level of increase may be based upon a set percentage of

increase and may be based upon an iterative process where the level of increase is performed during each cycle until the flow rate (FR) equals or exceeds the flow rate setpoint (FRset). As another example, the level of increase may be based upon historical data that indicates the level of temperature change in the areas affected by the CRAC units 108, 110, 110' in response to various VFD speeds.

Also, at step 466, for those CRAC units 108, 110, 110' having caloric heat transfer rates (Q) that are below the minimum set point caloric heat transfer level (Qset,min), those CRAC units 108, 110, 110' may enter a sleep mode as indicated at step 414. The sleep mode may include a powered down mode in which the CRAC units 108, 110, 110' draw reduced amounts of power as compared to when the CRAC units 108, 110, 110' are fully operational. The reduced amount of power may comprise a power state that is somewhere between the fully operational mode and a completely shut down mode. In addition, the sleep mode may constitute a power saving mode in which the CRAC units 108, 110, 110' may be reactivated or otherwise brought back to fully operational status in a relatively short period of time. The reduced power state of the CRAC unit 108, 110, 110' may vary for differing types of CRAC units.

In any regard, the sleep mode may include a mode in which the power supply to the temperature sensor 138 positioned to detect the temperature of the cooling fluid around the inlet of the CRAC unit 108, 110, 110', remains active. In addition, the sleep mode may also include the supply of a small amount of power to enable the blower to substantially continuously cause a relatively small amount of cooling fluid flow through the CRAC unit 108, 110, 110'. In this regard, the temperature of the cooling fluid supplied into the CRAC unit 108, 110, 110' may be substantially continuously monitored when the CRAC unit 108, 110, 110' is in the sleep mode.

The CRAC units 108, 110, 110' may exit from the sleep mode, for instance, when the calculated caloric heat transfer rates (Q) exceed the maximum setpoint caloric heat transfer level (Qset,max), as indicated at step 412. Alternatively, the CRAC units 108, 110, 110' may be configured to exit from the sleep mode when the return air temperature (Trat) exceeds another predefined temperature, which may be defined according to, for instance, operating requirements of the components to which the CRAC units 108, 110, 110' delivers cooling fluid. As another alternative, the CRAC units 108, 110, 110' may exit the sleep mode after a predetermined period of time, manually revived, in response to receipt of a setpoint temperature range, etc.

In another example, a plurality of CRAC units 108, 110, 110' may be networked or otherwise configured to communicate with one another. For instance, the same controller 204 may control the plurality of CRAC units 108, 110, 110'. In any regard, the controllers 204 of the CRAC units 108, 110, 110' may be configured to communicate their statuses to the other CRAC units 108, 110, 110'. The statuses of the CRAC units 108, 110, 110' may be used by the controllers 204 to determine the provisioning levels of the CRAC units 108, 110, 110'. By way of example, if one of the CRAC units 108, 110, 110' is in the sleep mode and the provisioning level of a neighboring CRAC unit 108, 110, 110' is too high, for instance, the return air temperature (Trat) into the neighboring CRAC unit 108, 110, 110' is above a predefined level, the CRAC unit 108, 110, 110' may be brought out of the sleep mode. In this instance, the return air temperature (Trat) may not need to be measured during the sleep mode thereby enabling that CRAC unit 108, 110, 110' to draw less power when in the sleep mode.

Through operation of the operational modes **400** and **450**, the energy consumption levels of the CRAC units **108**, **110**, **110'** and therefore the costs associated with their operations may substantially be minimized. In one regard, the CRAC units **108**, **110**, **110'** may be operated substantially independently from one another in manners to generally enable their energy efficient operations.

The operations set forth in the operational modes **400** and **450** may be contained as utilities, programs, or subprograms, in any desired computer accessible medium. In addition, the operational modes **400** and **450** may be embodied by computer programs, which can exist in a variety of forms both active and inactive. For example, it can exist as software program(s) comprised of program instructions in source code, object code, executable code or other formats. Any of the above can be embodied on a computer readable medium, which include storage devices and signals, in compressed or uncompressed form.

Exemplary computer readable storage devices include conventional computer system RAM, ROM, EPROM, EEPROM, and magnetic or optical disks or tapes. Exemplary computer readable signals, whether modulated using a carrier or not, are signals that a computer system hosting or running the computer program can be configured to access, including signals downloaded through the Internet or other networks. Concrete examples of the foregoing include distribution of the programs on a CD ROM or via Internet download. In a sense, the Internet itself, as an abstract entity, is a computer readable medium. The same is true of computer networks in general. It is therefore to be understood that any electronic device capable of executing the above-described functions may perform those functions enumerated above.

FIG. 5 illustrates an exemplary computer system **500**, according to an embodiment of the invention. The computer system **500** may include, for example, the controllers **204** and/or the computing device **112**. In this respect, the computer system **500** may be used as a platform for executing one or more of the functions described hereinabove with respect to the various components of the CRAC control systems **202**, **252**, **252'**.

The computer system **500** includes one or more controllers, such as a processor **502**. The processor **502** may be used to execute some or all of the steps described in the operational modes **400** and **450**. Commands and data from the processor **502** are communicated over a communication bus **504**. The computer system **500** also includes a main memory **506**, such as a random access memory (RAM), where the program code for, for instance, the controllers **204** and/or the controller of the computing device **112**, may be executed during runtime, and a secondary memory **508**. The secondary memory **508** includes, for example, one or more hard disk drives **510** and/or a removable storage drive **512**, representing a floppy diskette drive, a magnetic tape drive, a compact disk drive, etc., where a copy of the program code for the provisioning system may be stored.

The removable storage drive **510** reads from and/or writes to a removable storage unit **514** in a well-known manner. User input and output devices may include a keyboard **516**, a mouse **518**, and a display **520**. A display adaptor **522** may interface with the communication bus **504** and the display **520** and may receive display data from the processor **502** and convert the display data into display commands for the display **520**. In addition, the processor **502** may communicate over a network, e.g., the Internet, LAN, etc., through a network adaptor **524**.

It will be apparent to one of ordinary skill in the art that other known electronic components may be added or substi-

tuted in the computer system **500**. In addition, the computer system **500** may include a system board or blade used in a rack in a data center, a conventional "white box" server or computing device, etc. Also, one or more of the components in FIG. 5 may be optional (e.g., user input devices, secondary memory, etc.).

What has been described and illustrated herein is a preferred embodiment of the invention along with some of its variations. The terms, descriptions and figures used herein are set forth by way of illustration only and are not meant as limitations. Those skilled in the art will recognize that many variations are possible within the spirit and scope of the invention, which is intended to be defined by the following claims—and their equivalents—in which all terms are meant in their broadest reasonable sense unless otherwise indicated.

What is claimed is:

[1. A method for controlling one or more computer room air conditioning (CRAC) units for energy efficient operation, wherein said CRAC units comprise a cooling system and a blower, said one or more CRAC units being configured to receive return air, and wherein said cooling system comprises at least one of a refrigerant and a coolant configured to cool the return air, said method comprising:

- detecting a power consumption of the cooling system;
- detecting a power consumption of the blower;
- calculating costs associated with the cooling system power consumption and the blower power consumption;
- comparing the costs associated with increasing the temperature of the at least one of the refrigerant and the coolant and the costs associated with decreasing the volume flow rate of air delivered by the blower; and
- reducing at least one operation of the one or more CRAC units in response to the compared costs.]

[2. The method according to claim 1, wherein the step of reducing at least one operation of the one or more CRAC units comprises increasing the temperature of the at least one of the refrigerant and the coolant in response to the costs associated with increasing the temperature of the at least one of the refrigerant and the coolant being below the costs associated with decreasing the volume flow rate of air delivered by the blower; and

- wherein the step of reducing at least one operation of the one or more CRAC units comprises decreasing the volume flow rate of air delivered by the blower in response to the costs associated with decreasing the volume flow rate of air delivered by the blower being below the costs associated with increasing the temperature of the at least one of the refrigerant and the coolant.]

[3. The method according to claim 1, wherein the cooling system includes at least one of a refrigerant and a coolant configured to cool the return air, and wherein the step of calculating costs comprises calculating costs associated with increasing the temperature of at least one of the refrigerant and the coolant and decreasing a volume flow rate of air delivered by the blower, the method further comprising:

- determining a level of increased temperature of the at least one of the refrigerant and the coolant and a level of decreased volume flow rate of air delivered by the blower that relates to minimized costs associated with increasing the temperature of the at least one of the refrigerant and the coolant and with decreasing the volume flow rate of air delivered by the blower; and

wherein the step of reducing at least one operation of the one or more CRAC units comprises implementing the

23

determined level of increased temperature of the at least one of the refrigerant and the coolant and the determined level of the decreased volume flow rate of the air delivered by the blower.]

[4. The method according to claim 1, wherein the cooling system comprises at least one of a variable capacity compressor and a constant capacity compressor with a variable frequency drive (VFD), and wherein the step of reducing at least one operation of the one or more CRAC units comprises reducing the speed of the at least one of the variable capacity compressor and the constant capacity compressor with the VFD.]

[5. The method according to claim 1, wherein the cooling system comprises a three-way valve located upstream of a cooling coil, said cooling system further comprising a refrigeration circuit configured to cool a coolant for delivery into the cooling coil, said three-way valve being configured to control the temperature of the coolant contained in the cooling coil by controlling coolant delivery into the cooling coil, wherein the step of reducing a least one operation of the one or more CRAC units comprises reducing the coolant delivery into the cooling coil to thereby reduce the energy consumption of the refrigeration circuit in cooling the coolant.]

[6. The method according to claim 1, wherein the cooling system comprises a two-way valve located upstream of a cooling coil, said cooling system further comprising a refrigeration circuit configured to cool a coolant for delivery into the cooling coil, said two-way valve being configured to control the temperature of the coolant contained in the cooling coil by controlling coolant delivery into the cooling coil, wherein the step of reducing at least one operation of the one or more CRAC units comprises reducing the coolant delivery into the cooling coil to thereby reduce the energy consumption of the refrigeration circuit in cooling the coolant.]

[7. The method according to claim 1, wherein the blower comprises a variable frequency drive (VFD), and wherein the step of reducing at least one operation of the one or more CRAC units comprises operating the VFD to reduce the speed of the blower to thereby reduce to power consumption of the blower.]

[8. A method for controlling one or more computer room air conditioning (CRAC) units for energy efficient operation, wherein said CRAC units comprise a cooling system and a blower, said one or more CRAC units being configured to receive return air, and wherein said cooling system comprises at least one of a refrigerant and a coolant configured to cool the return air, said method comprising:

detecting the temperature of the air returned (Trat) into the one or more CRAC units;

determining whether the Trat is below a minimum setpoint temperature level-in

calculating costs associated with decreasing the temperature of at least one of the refrigerant and the coolant;

calculating costs associated with increasing a volume flow rate of air delivered by the blower;

comparing the costs associated with decreasing the temperature of at least one of the refrigerant and the coolant and the costs associated with increasing the volume flow rate of air delivered by the blower; and

operating the one or more CRAC units to at least one of decrease a temperature of at least one of a refrigerant and a coolant and increase a volume flow rate of cooling fluid delivered by a blower of the one or more CRAC units in response to the Trat being above the minimum setpoint temperature level.]

[9. The method according to claim 8 wherein the step of operating the one or more CRAC units comprises decreasing

24

the temperature of the at least one of the refrigerant and the coolant in response to the costs associated with decreasing the temperature of the at least one of the refrigerant and the coolant being below the costs associated with increasing the volume flow rate of air delivered by the blower;

end wherein the step of operating the one or more CRAC units comprises increasing the volume flow rate of air delivered by the blower in response to the costs associated with increasing the volume flow rate of air delivered by the blower being below the costs associated with decreasing the temperature of the at least one of the refrigerant and the coolant.]

[10. The method according to claim 8 wherein the step of calculating costs comprises calculating costs associated with decreasing the temperature of at least one of the refrigerant and the coolant and increasing a volume flow rate of air delivered by the blower, the method further comprising:

determining a level of decreased temperature of the at least one of the refrigerant and the coolant and a level of increased volume flow rate of air delivered by the blower that relates to minimized costs associated with decreasing the temperature of the at least one of the refrigerant and the coolant and with increasing the volume flow rate of air delivered by the blower; and

wherein the step of operating the one or more CRAC units comprises implementing the determined level of decreased temperature of the at least one of the refrigerant and the coolant and the determined level of the increased volume flow rate of the air delivered by the blower.]

[11. The method according to claim 8 further comprising causing the one or more CRAC units to enter into a reduced power mode in response to the Trat being below the minimum setpoint temperature level.]

[12. The method according to claim 11 further comprising:

detecting the Trat while the one or more CRAC units are in the reduced power mode; and

causing the one or more CRAC units to exit from the reduced power mode in response to the Trat exceeding a predefined temperature level.]

[13. The method according to claim 11 wherein the one or more CRAC units comprise a plurality of CRAC units, and wherein the plurality of CRAC units are configured to communicate with each other, the method further comprising:

signaling a CRAC unit to exit from the reduced power mode in response to a Trat of another CRAC unit exceeding a predefined level.]

[14. The method according to claim 1, wherein the one or more CRAC units comprise a plurality of CRAC units, and wherein one or more of the plurality of CRAC units are configured with at least one of a three-way valve and a two-way valve to control coolant delivery into a cooling coil of the one or more of the CRAC units, the method further comprising:

operating the plurality of CRAC units to enable the one or more of the plurality of CRAC units to maintain the at least one of the three-way valve and the two-way valve substantially at 100% open positions to thereby reduce energy usage by the one or more of the plurality of CRAC units.]

[15. A computer room air conditioning (CRAC) unit comprising:

a return air temperature sensor; and

a controller configured to compare the temperature of the return air (Trat) with a predetermined setpoint tempera-

25

ture range to determine whether the Trat is below a minimum setpoint temperature level in response to the Trat being outside of the predetermined setpoint temperature range, wherein the controller is further configured to reduce at least one operation of the CRAC unit by at least one of decreasing a temperature of cooling fluid delivered by the CRAC unit and increasing a volume flow rate of cooling fluid delivered by the CRAC unit in response to the Trat being above the minimum setpoint temperature level and wherein the controller is configured to cause the CRAC unit to enter into a reduced power mode in response to the Trat being below the minimum setpoint temperature level and cause the CRAC unit to withdraw the CRAC unit from the reduced power mode in response to the detected Trat exceeding a predefined temperature level.]

[16. The CRAC unit of claim 15, further comprising:

a cooling system;

a blower; and

a power meter configured to detect a power consumption of the cooling system and the blower,

wherein the controller is configured to calculate costs associated with the power consumptions of the cooling system and the blower and to base the reduction of the at least one operation of the CRAC unit on the costs associated with operating the cooling system and the blower.]

[17. The CRAC unit according to claim 16 wherein the cooling system comprises at least one of a variable capacity compressor and a constant capacity compressor with a variable frequency drive (VFD), and wherein the controller is operable to reduce operations of the at least one of the variable capacity compressor and the constant capacity compressor with a VFD in response to the temperature of the return air being within the predetermined setpoint temperature range.]

[18. The CRAC unit according to claim 16 wherein the cooling system comprises a three-way valve located upstream of a cooling coil, said cooling system further comprising a refrigeration circuit configured to cool a coolant for delivery into the cooling coil, said three-way valve being configured to control the temperature of the coolant contained in the cooling coil by controlling coolant delivery into the cooling coil, wherein the controller is configured to operate the three-way valve to reduce the coolant delivery into the cooling coil in response to the return air being within the predetermined setpoint temperature range.]

[19. The CRAC unit according to claim 16 wherein the cooling system comprises a two-way valve located upstream of a cooling coil, said cooling system further comprising a refrigeration circuit configured to cool a coolant for delivery into the cooling coil, said two-way valve being configured to control the temperature of the coolant contained in the cooling coil by controlling coolant delivery into the cooling coil, wherein the controller is configured to operate the two-way valve to reduce the coolant delivery into the cooling coil in response to the return air being within the predetermined setpoint temperature range.]

[20. The CRAC unit according to claim 16 wherein the blower comprises a variable frequency drive (VFD), and wherein the controller is configured to operate the VFD to reduce the speed of the blower in response to the return air being within the predetermined setpoint temperature range.]

[21. A system for controlling a computer room air conditioning (CRAC) unit, said system comprising:

means for detecting a temperature of air returned (Trat) into the CRAC unit;

26

means for determining whether the Trat is within a predetermined setpoint temperature range, said means for determining also including means for reducing at least one operation of the CRAC unit in response to the Trat being within the predetermined setpoint temperature range; and

means for causing CRAC unit to enter into a reduced power mode in response to the Trat being below the minimum setpoint temperature level, said means for detecting Trat being configured to detect the Trat while the CRAC unit is in the reduced power mode, and wherein the means for determining is further configured to cause the CRAC unit to exit from the reduced power mode in response to the Trat exceeding a predefined temperature level.]

[22. The system according to claim 21 further comprising: means for varying a temperature of cooling fluid supplied by the CRAC unit;

means for varying a volume flow rate of cooling fluid supplied by the CRAC unit; and

means for detecting a power consumption of the means for varying temperature and the means for varying volume flow rate, wherein the means for determining comprises means for calculating costs associated with the power consumptions of the means for varying temperature and the means for varying volume flow rate.]

[23. The system according to claim 22 wherein the means for determining further comprises means for comparing the Trat to a minimum setpoint temperature level, said means for determining further comprising means for operating at least one of the means for varying temperature and the means for varying volume flow rate to operate at reduced energy consumption levels in response to the Trat being below the minimum setpoint temperature level.]

[24. A computer readable storage medium on which is embedded one or more computer programs, said one or more computer programs implementing a method for controlling a computer room air conditioning (CRAC) unit for energy efficient operation, said CRAC unit being configured to receive return air, said one or more computer programs comprising a set of instructions for:

detecting the temperature of the air returned (Trat) into the CRAC unit;

determining whether the Trat is within a predetermined setpoint temperature range;

determining whether the Trat is below a minimum setpoint temperature level in response to the Trat being outside of the predetermined setpoint temperature range;

causing the CRAC unit to enter into a reduced power mode in response to the Trat being below the minimum setpoint temperature level;

detecting the Trat while the CRAC unit is in the reduced power mode; and causing the CRAC unit to exit from the reduced power mode in response to the Trat exceeding a predefined temperature level.]

[25. The computer readable storage medium according to claim 24, said one or more computer programs further comprising a set of instructions for:

operating the CRAC unit to at least one of decrease a temperature of cooling fluid delivered by the CRAC unit and increase a volume flow rate of cooling fluid delivered by the CRAC unit in response to the Trat being above the minimum setpoint temperature level.]

26. A method for controlling one or more computer room air conditioning (CRAC) units for energy efficient operation,

27

said one or more CRAC units comprising a cooling system having at least one of a refrigerant and a coolant, and a blower, said one or more CRAC units being configured to receive return air, cool said received air and supply the cooled air, said method comprising:

detecting the temperature of the air returned (T_{rat}) into the one or more CRAC units;

detecting the temperature of the air supplied (T_{sat}) by the one or more CRAC units;

calculating a caloric heat transfer level (Q) based upon the T_{rat} and the T_{sat} ;

determining whether the Q is within a predetermined setpoint caloric heat transfer range;

detecting a power consumption of the cooling system;

detecting a power consumption of the blower;

calculating costs associated with the cooling system power consumption and the blower power consumption, wherein the step of calculating costs comprises calculating costs associated with increasing the temperature of at least one of the refrigerant and the coolant and calculating costs associated with decreasing a volume flow rate of air delivered by the blower;

comparing the costs associated with increasing the temperature of at least one of the refrigerant and the coolant and the costs associated with decreasing the volume flow rate of air delivered by the blower; and

reducing at least one operation of at least one of the cooling system and the blower to reduce the costs associated with operating at least one of the cooling system and the blower and thereby increase the efficiencies of the one or more CRAC units.

27. The method according to claim 26, wherein the step of reducing at least one operation of the one or more CRAC units comprises increasing the temperature of the at least one of the refrigerant and the coolant in response to the costs associated with increasing the temperature of the at least one of the refrigerant and the coolant being below the costs associated with decreasing the volume flow rate of air delivered by the blower; and

wherein the step of reducing at least one operation of the one or more CRAC units comprises decreasing the volume flow rate of air delivered by the blower in response to the costs associated with decreasing the volume flow rate of air delivered by the blower being below the costs associated with increasing the temperature of the at least one of the refrigerant and the coolant.

28. The method according to claim 26, wherein the cooling system includes at least one of a refrigerant and a coolant configured to cool the return air, and wherein the step of calculating costs comprises calculating costs associated with increasing the temperature of at least one of the refrigerant and the coolant and decreasing a volume flow rate of air delivered by the blower, the method further comprising:

determining a level of increased temperature of the at least one of the refrigerant and the coolant and a level of decreased volume flow rate of air delivered by the blower that relates to minimized costs associated with increasing the temperature of the at least one of the refrigerant and the coolant and with decreasing the volume flow rate of air delivered by the blower; and

wherein the step of reducing at least one operation of the one or more CRAC units comprises implementing the determined level of increased temperature of the at least one of the refrigerant and the coolant and the determined level of the decreased volume flow rate of the air delivered by the blower.

28

29. The method according to claim 26, wherein the cooling system comprises at least one of a variable capacity compressor and a constant capacity compressor with a variable frequency drive (VFD), and wherein the step of reducing at least one operation of the one or more CRAC units comprises reducing the speed of the at least one of the variable capacity compressor and the constant capacity compressor with the VFD.

30. The method according to claim 26, wherein the cooling system comprises a three-way valve located upstream of a cooling coil, said cooling system further comprising a refrigeration circuit configured to cool a coolant for delivery into the cooling coil, said three-way valve being configured to control the temperature of the coolant contained in the cooling coil by controlling coolant delivery into the cooling coil, wherein the step of reducing at least one operation of the one or more CRAC units comprises reducing the coolant delivery into the cooling coil to thereby reduce the energy consumption of the refrigeration circuit in cooling the coolant.

31. The method according to claim 26, wherein the cooling system comprises a two-way valve located upstream of a cooling coil and a mass flow sensor located along a coolant line of the two-way valve, said cooling system further comprising a refrigeration circuit configured to cool a coolant for delivery into the cooling coil, said two-way valve being configured to control the temperature of the coolant contained in the cooling coil by controlling coolant delivery into the cooling coil, wherein the step of calculating a caloric heat transfer level (Q) comprises calculating the Q based upon the T_{rat} , the T_{sat} , and a measured mass flow through the coolant line, and wherein the step of reducing at least one operation of the one or more CRAC units comprises reducing the cooling delivery into the cooling coil to thereby reduce the energy consumption of the refrigeration circuit in cooling the coolant.

32. The method according to claim 26, wherein the blower comprises a variable frequency drive (VFD), and wherein the step of reducing at least one operation of the one or more CRAC units comprises operating the VFD to reduce the speed of the blower to thereby reduce the power consumption of the blower.

33. The method according to claim 26, further comprising:

determining whether the Q is below a minimum setpoint caloric heat transfer level in response to the Q being outside the predetermined setpoint caloric heat transfer range;

determining a volume flow rate of air supplied by the one or more CRAC units;

comparing the volume flow rate of air with a flow rate setpoint; and

increasing the volume flow rate of air supplied by the one or more CRAC units in response to the flow rate falling below the volume flow rate of air setpoint.

34. The method according to claim 33, further comprising:

causing the one or more CRAC units to enter into a reduced power mode in response to the Q being below the minimum setpoint caloric heat transfer level;

detecting the T_{rat} and the T_{sat} while the one or more CRAC units are in the reduced power mode;

calculating the Q while the one or more CRAC units are in the reduced power mode; and

causing the one or more CRAC units to exit from the reduced power mode in response to the Q exceeding a predefined caloric heat transfer level.

35. The method according to claim 34, further comprising:

causing the one or more CRAC units to enter into a reduced power mode in response to the Q being below the minimum setpoint caloric heat transfer level;

wherein the one or more CRAC units comprise a plurality of CRAC units, and wherein the plurality of CRAC units are configured to communicate with each other, the method further comprising:

signaling a CRAC unit to exit from the reduced power mode in response to a Q of another CRAC unit exceeding a predefined level.

36. The method according to claim 26, wherein the one or more CRAC units comprise a plurality of CRAC units, and wherein one or more of the plurality of CRAC units are configured with at least one of a three-way valve and a two-way valve to control coolant delivery into a cooling coil of the one or more of the CRAC units, the method further comprising:

operating the plurality of CRAC units to enable the one or more of the plurality of CRAC units to maintain the at least one of the three-way valve and the two-way valve substantially at 100% open positions to thereby reduce energy usage by the one or more of the plurality of CRAC units.

37. A computer room air conditioning (CRAC) unit comprising:

a cooling system, a blower, and a power meter configured to detect a power consumption of the cooling system and the blower;

a first sensor configured to detect a temperature of return air (T_{rat});

a second sensor configured to detect a temperature of supply air (T_{sat}); and

a controller configured to calculate a caloric heat transfer level (Q) based upon the T_{rat} and the T_{sat} , wherein the controller is also configured to determine whether the Q is within a predetermined setpoint caloric heat transfer range and to determine whether the Q is below a minimum setpoint caloric heat transfer level in response to the Q being outside of the predetermined setpoint caloric heat transfer range, wherein the controller is configured to cause the CRAC unit to enter into a reduced power mode in response to the Q being below the minimum setpoint caloric heat transfer level; and

wherein the first temperature sensor is configured to detect the T_{rat} and the second temperature sensor is configured to detect the T_{sat} while the CRAC unit is in the reduced power mode, wherein the controller is configured to calculate the Q while the CRAC unit is in the reduced power mode, and wherein the controller is configured to withdraw the CRAC unit from the reduced power mode in response to the Q exceeding a predefined caloric heat transfer level.

38. The CRAC unit according to claim 37, wherein the controller is configured to calculate costs associated with the power consumptions of the cooling system and the blower and to base the reduction of the at least one operation of the CRAC unit on the costs associated with operating the cooling system and the blower.

39. The CRAC unit according to claim 37, wherein the cooling system comprises at least one of a variable capacity compressor and a constant capacity compressor with a variable frequency drive (VFD), and wherein the controller is operable to reduce operations of the at least one of the vari-

able capacity compressor and the constant capacity compressor with a VFD in response to the temperature of the return air being within a predetermined setpoint temperature range.

40. The CRAC unit according to claim 37, wherein the cooling system comprises a three-way valve located upstream of a cooling coil, said cooling system further comprising a refrigeration circuit configured to cool a coolant for delivery into the cooling coil, said three-way valve being configured to control the temperature of the coolant contained in the cooling coil by controlling coolant delivery into the cooling coil, wherein the controller is configured to operate the three-way valve to reduce the coolant delivery into the cooling coil in response to the return air being within a predetermined setpoint temperature range.

41. The CRAC unit according to claim 37, wherein the cooling system comprises a two-way valve located upstream of a cooling coil and a mass flow sensor located along a coolant line of the two-way valve, said cooling system further comprising a refrigeration circuit configured to cool a coolant for delivery into the cooling coil, said two-way valve being configured to control the temperature of the coolant contained in the cooling coil by controlling coolant delivery into the cooling coil, wherein the controller is configured to calculate the Q based upon the T_{rat} , the T_{sat} , and a measured mass flow through the coolant line, and wherein the controller is configured to operate the two-way valve to reduce the coolant delivery into the cooling coil in response to the Q being within the predetermined setpoint caloric heat transfer range.

42. The CRAC unit according to claim 37, wherein the blower comprises a variable frequency drive (VFD), and wherein the controller is configured to operate the VFD to reduce the speed of the blower in response to the Q being within the predetermined setpoint caloric heat transfer range.

43. A system for controlling a computer room air conditioning (CRAC) unit, said system comprising:

means for varying a temperature of air supplied by the CRAC unit;

means for varying a volume flow rate of air supplied by the CRAC unit;

means for detecting a power consumption of the means for varying temperature and the means for varying volume flow rate;

means for detecting a temperature of air returned (T_{rat}) into the CRAC unit;

means for detecting a temperature of air supplied (T_{sat}) by the CRAC unit;

means for calculating a caloric heat transfer level (Q) based upon the detected T_{rat} and T_{sat} , wherein the means for calculating comprises means for determining whether the Q is within a predetermined setpoint caloric heat transfer range, the means for calculating further comprising means for reducing at least one operation of the CRAC unit in response to the Q being within the predetermined setpoint caloric heat transfer range;

wherein the means for determining further comprises means for comparing the Q to a minimum setpoint caloric heat transfer level, said means for determining further comprising means for operating at least one of the means for varying temperature and the means for varying volume flow rate to operate at reduced energy consumption levels in response to the Q being below the minimum setpoint caloric heat transfer level; and

31

wherein the means for determining further comprises means for causing the CRAC unit to enter into a reduced power mode in response to the Q being below the minimum setpoint caloric heat transfer level, said means for detecting T_{rat} being configured to detect the T_{rat} and the means for detecting T_{sat} being configured to detect the T_{sat} while the CRAC unit is in the reduced power mode, and wherein the means for determining is further configured to cause the CRAC unit to exit from the reduced power mode in response to the Q exceeding a predefined caloric heat transfer level.

44. The system according to claim 43, wherein the means for determining further comprises means for calculating costs associated with the power consumptions of the means for varying temperature and the means for varying volume flow rate.

45. A computer readable storage medium on which is embedded one or more computer programs, said one or more computer programs implementing a method for controlling a computer room air conditioning (CRAC) unit for energy efficient operation, said CRAC unit being configured to receive return air, cool said received air and supply the cooled air, said one or more computer programs comprising a set of instructions for:

- detecting the temperature of the air returned (T_{rat}) into the CRAC unit;
- detecting the temperature of the air supplied (T_{sat}) by the CRAC unit;
- calculating a caloric heat transfer level (Q) based upon the T_{rat} and the T_{sat} ;

32

determining whether the Q is within a predetermined setpoint caloric heat transfer range;

determining whether the Q is below a minimum setpoint caloric heat transfer level in response to the Q being outside the predetermined setpoint caloric heat transfer range;

causing the CRAC unit to enter into a reduced power mode in response to the Q being below the minimum setpoint caloric heat transfer level;

detecting the T_{rat} and the T_{sat} while the CRAC unit is in the reduced power mode;

calculating the Q while the CRAC unit is in the reduced power mode; and

causing the CRAC unit to exit from the reduced power mode in response to the Q exceeding a predefined caloric heat transfer level.

46. The computer readable storage medium according to claim 45, said one or more computer programs further comprising a set of instructions for:

operating the CRAC unit to at least one of decrease a temperature of air delivered by the CRAC unit and increase a volume flow rate of air delivered by the CRAC unit in response to the Q being above the minimum setpoint caloric heat transfer level.

* * * * *

UNITED STATES PATENT AND TRADEMARK OFFICE
CERTIFICATE OF CORRECTION

PATENT NO. : RE42,195 E
APPLICATION NO. : 11/594721
DATED : March 1, 2011
INVENTOR(S) : Cullen E. Bash et al.

Page 1 of 1

It is certified that error appears in the above-identified patent and that said Letters Patent is hereby corrected as shown below:

In column 11, line 12, after “scope” insert -- of --.

In column 28, line 53, in Claim 33, after “rate” insert -- of air --.

In column 31, line 16, in Claim 45, after “A” insert -- tangible --.

In column 32, line 19, in Claim 46, after “The” insert -- tangible --.

Signed and Sealed this
Twenty-seventh Day of November, 2012

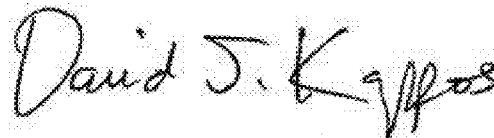
A handwritten signature in black ink that reads "David J. Kappos". The signature is written in a cursive, slightly slanted style.

David J. Kappos
Director of the United States Patent and Trademark Office