



- (51) **International Patent Classification:**  
*A61F 5/453* (2006.01) *A61F 5/44* (2006.01)
- (21) **International Application Number:**  
PCT/IL2014/000066
- (22) **International Filing Date:**  
24 December 2014 (24.12.2014)
- (25) **Filing Language:** English
- (26) **Publication Language:** English
- (71) **Applicant:** GR DOME MEDICAL [IL/IL]; Derech Hayam 209, apartment 49, 34890 Haifa (IL).
- (72) **Inventor; and**
- (71) **Applicant :** LANIADO, Amir [IL/IL]; Derech Hayam Street 209, apartment 49, 34890 Haifa (IL).
- (74) **Agent:** GAVRIELI, Jonah; 34 Golomb St., Kiryat Tivon 3602256 (IL).
- (81) **Designated States** (*unless otherwise indicated, for every kind of national protection available*): AE, AG, AL, AM, AO, AT, AU, AZ, BA, BB, BG, BH, BN, BR, BW, BY,

BZ, CA, CH, CL, CN, CO, CR, CU, CZ, DE, DK, DM, DO, DZ, EC, EE, EG, ES, FI, GB, GD, GE, GH, GM, GT, HN, HR, HU, ID, IL, IN, IR, IS, JP, KE, KG, KN, KP, KR, KZ, LA, LC, LK, LR, LS, LU, LY, MA, MD, ME, MG, MK, MN, MW, MX, MY, MZ, NA, NG, NI, NO, NZ, OM, PA, PE, PG, PH, PL, PT, QA, RO, RS, RU, RW, SA, SC, SD, SE, SG, SK, SL, SM, ST, SV, SY, TH, TJ, TM, TN, TR, TT, TZ, UA, UG, US, UZ, VC, VN, ZA, ZM, ZW.

- (84) **Designated States** (*unless otherwise indicated, for every kind of regional protection available*): ARIPO (BW, GH, GM, KE, LR, LS, MW, MZ, NA, RW, SD, SL, ST, SZ, TZ, UG, ZM, ZW), Eurasian (AM, AZ, BY, KG, KZ, RU, TJ, TM), European (AL, AT, BE, BG, CH, CY, CZ, DE, DK, EE, ES, FI, FR, GB, GR, HR, HU, IE, IS, IT, LT, LU, LV, MC, MK, MT, NL, NO, PL, PT, RO, RS, SE, SI, SK, SM, TR), OAPI (BF, BJ, CF, CG, CI, CM, GA, GN, GQ, GW, KM, ML, MR, NE, SN, TD, TG).

**Published:**

— with international search report (Art. 21(3))

- (54) **Title:** A DEVICE AND METHOD FOR EXTERNAL URINARY INCONTINENCE TREATMENT FOR MEN

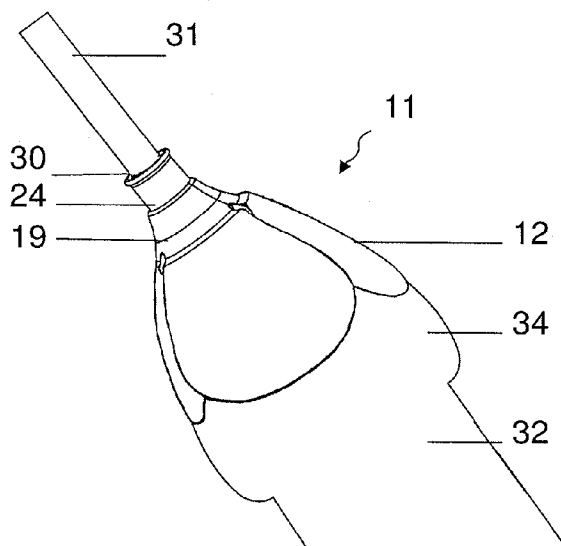

**Fig. 7**

(57) **Abstract:** The present invention is a device and method for external urinary incontinence treatment for men that can be self-deployed by a patient or by a care giver. Via the device, a urine removal tube is reversibly connected to the glans penis of a treated patient for the removal of urine from a treated patient. The device of the present invention is composed of a penis connecting component and a tube connector component. The tube connector component reversibly contact-connects a urine receiving component to the glans penis of a treated patient. The tube connector component is reversibly connected, anchored and fixated in place to the glans penis of the treated patient by the penis connection component. The connection, disconnection and again reconnection of the penis connection component to the glans penis is easy and simple to carry out. The connection stabilizes, fixates and adjusts the tightness of the contact-connection between the skin surrounding the orifice of the urethral tract of a treated patient and the urine receiving component. The urine receiving component has spring-like characteristics bestowed by "accordion-like" components that enable a urine leak-free contact-connection while minimizing the discomfort caused to the treated patient.



**A DEVICE AND METHOD FOR EXTERNAL URINARY INCONTINENCE  
TREATMENT FOR MEN**

**[0001]**

FIELD OF THE INVENTION

**[0002]** The present invention relates to a device and method for external urinary incontinence treatment for men. More specifically, the present invention relates to a device and method for the external urinary incontinence treatment for men that reversibly contact-connects a urine receiving component that has spring-like characteristics to the skin surrounding the external urethral orifice in a urine leak-free connection in a that is easy to adjust so as to minimize the discomfort caused to the treated patient. The device of the present invention is self-deployed by a patient or is deployed by a care giver.

**[0003]**

BACKGROUND OF THE INVENTION

**[0004]** The preferred treatment of urinary incontinence in men it is often the use of a device that externally connects to the body of the treated patient and collects urine directly from the external orifice of the ureteral tract without penetrating into the orifice. Typically in the various external incontinence treatment devices that have been described in publications, a component that directly receives the urine from the urethral orifice without penetrating the orifice is utilized. The component directs the urine without leaks to a tube that drains the urine to a collection vessel, typically a disposable bag. The urine draining tube is also referred in the following text as: the urine removal tube. The urine receiving component from the orifice of the urethral tract in the text that follows is also referred to interchangeably as the "receiving component" and is also written in an abbreviated form, as: URC.

**[0005]** Some of the disclosed external urinary incontinence treatment devices for men connect the device to the penis by a "condom-like" tube that tightly wraps around the penis and has an opening at the tip that connects to a tube that removes the urine to a collecting vessel, typically a bag. The

"condom-like" urinary incontinence treatment devices do not facilitate often and readily adjustment of the devices to the physiology of the treated patients and, when utilized for periods longer than a few hours, the constant tight contact between the large surface area of the devices and the skin of the patients causes skin-irritations. An examples of "condom-like" urinary incontinence treatment devices is give in NL8,602,986 (Wilhelmus).

Another approach for external urinary incontinence treatment devices is reversibly connecting the URC of the device (only) to the glans penis of the treated patient. Such devices substantially reduce the total contact area between the skin of the treated patient and the urinary incontinence treatment device but require, in order to prevent urine leaks, the forming of a stable and tight connection between the skin of the glans penis and the device. Examples of glans penis connected devices are given in: US5,263,947 (Kay) and PCT/IL2014/000039 (Laniado).

[0006] Laniado discloses an external urinary incontinence treatment device that enables the changing of the position and tightness of the connection in the course of treatment between the receiving component and the skin of the glans penis by the use of a locking system. The locking system enables the motion and positioning of the receiving component to provide a desired connection while minimizing the discomfort of the treated patient.

[0007] The present invention of a device and method for external urinary incontinence treatment for men provides a device in which the receiving component reversibly connects to the glans penis of the treated patient by an "accordion" pressure mechanism that provides a stable yet substantially better adjustable connection than the connection described in PCT/IL2014/000039.

[0008]

[0009]

#### SUMMARY OF THE INVENTION

[0010] The present invention is a device and method for reversibly connecting in an external-body connection, a urine removal tube to the glans penis of a treated patient for the removal of urine to a urine collection vessel (typically a disposable collection bag). The connection, disconnection and again reconnection of the device of the present invention to the glans penis, is easy and simple to establish while minimizing the discomfort created by the connection. The device of the present invention is either self-deployed by a patient or is deployed by a care giver to a treated patient.

[0011] The ability of external urinary incontinence treatment devices to collect urine without spills to the surrounding while causing the user minimal discomfort relates to the spatial configuration of the urine receiving component and to the manner in which the receiving component is reversibly connected, adjusted, fastened and fixated to the penis, near and/or over the orifice of the urethra. The term "adjusted" in context of the receiving component of the present invention refers to minor placement and tightening movements of the component to comfortably connect to the skin in the near or over the orifice of the urethra. The term "fastened" in context of the receiving component of the present invention, is used to describe the tightening of the receiving component to the skin surface surrounding the orifice of the urethra of a treated patient in manner that produces a reversible urine leak-free connection. The term "leak-free connection" refers to a connection that prevents the spillage of urine to the surrounding while passing from the urethral tract of the treated patient on its way to a collecting vessel.

[0012] The term "contact-connection" in the text refers to a connection in which the connection between surfaces is established and kept by pressuring the surfaces to each other and where no adhesive material nor mechanical means to maintain the connection is used.

[0013] The terms "proximal" and "dorsal" in the text relate to a directional reference of either being in the direction towards the body and away from the body of the treated patient, respectively.

[0014] The skin of the glans penis is especially sensitive to touch, thus, with an increase of pressure applied to the skin of the glans penis of a treated patient the discomfort caused to the patient increases. In reversibly contact-connecting an URC of an external urinary incontinence treatment device to the skin surrounding the orifice of the urethral tract in the glans penis, it is desired that the contact-connection be leak-free yet be in a tightness that minimizes the discomfort cause to the treated patient.

[0015] In accordance to the device and method for the treatment of external urinary incontinence for men of the present invention, devices are constructed of: a urine removal tube connector component (also referred to interchangeably as the: tube connector component and the TCC) and a penis connection component (also referred to as: PCC). The TCC forms a tight urine leak-free contact-connection with the skin that surround the external orifice of the ureteral tract of a treated patient and reversibly connects and communicates freely with a urine-

removing-tube that flows the urine discharged from the orifice to a urine collecting vessel, typically a urine collection bag. The PCC reversibly anchors, stabilizes and fixates the TCC to the glans penis of the treated patient.

[0016] The TCC is constructed of two connected components: a glans penis stabilization component (also referred to as GPSC) and a urine receiving component (also referred to as: URC). The PCC is constructed of at least one connection-sheet-component (also referred to as: CSC) having a sticky, adhesive material coated layer side, and at least one connection-sheet-protection-component (also referred to as: CSPC) that reversibly connects to the sticky side of the CSC prior to the deployment of the device of the present invention.

[0017] Reference is presently made to the construction of the components of a device for external urinary incontinence treatment for men of the present invention.

[0018] The components of the TCC, the GPSC and the URC, are produced as a single entity component or, alternatively, they are produced as two separate entity components and are connected prior to the deployment of the device for the treatment of external urinary incontinence for men of the present invention.

[0019] The GPSC of the TCC is hollow dome structure made of a semi-rigid flexible material that has a hole at the dorsal, ("top-side") of the dome and least two sheets, referred to as: "stabilizing-sheets", made of a semi-rigid flexible material that protrude and connect to the proximal-side ("bottom side"), circumference rim of the dome. The stabilizing-sheets have a concaved configuration and they fully surround or, alternatively, partially surround, the rim of the hollow dome and form segmented-hollow-dome spatial structure.

[0020] The URC is typically produced as a single entity component that is constructed of: a first tube, a hollow dome which extends to hollow tube with a hole at its top, and a second tube. The first tube connects through the tube of the dome and the hollow dome to the second tube. The proximal-side rim of the hollow dome connects to the rim of the second tube. The first and second tube communicate freely between them and enable the free flow of urine from the free opening (proximal side) of the second tube to the free opening (dorsal side) of the first tube. The proximal-side rim of the free opening of the second tube reversibly contact-connects with the skin surrounding the orifice of the urethral tract, the free opening of the first tube connects with a tube that flows urine to a collecting vessel, typically a urine collection bag. The

hollow dome and the second tube are interchangeably referred to in the context of the present invention as the: "accordion dome" and "accordion tube", respectively.

The URC connects to the GPSC by inserting the first tube of the URC into the hole (in "top-side") of the dome of the GPSC. The friction between the rim of the hole and the external surface of the tube maintains the connection between the components.

[0021] The Internet Dictionary.com (<http://dictionary.reference.com/browse/accordion-fold>) defines the adjective "accordion" as: having a fold or folds like the bellows of an accordion (musical instrument)". In the context of the present invention the term "accordion tube" and "accordion dome" refers to a tube and dome structures, respectively, constructed of parallel connected hoops. The tubes are constructed of and are connected by a semi-rigid material such as, but not limited to, silicon or rubber. The connected hoops form ribbed-shaped structures that have resiliency in the longitudinal dimension, bestowing flexible spring-like characteristics to the URC. The "accordion configuration" of the dome structure facilitates side-way (swaying) movements of the first tube of the URC and the "accordion configuration" of the accordion tube facilitates, softness yet tightness of the contact-connection between the rim of the proximal opening of the accordion tube and the skin of the glans penis of the treated patient, according to changing patient's body postures and inside URC urine-pressure conditions. The softening of the tightness is achieved by delicately compressing and/or decompressing the accordion tube, thus delicately changing the length of the tube and the pressure applied by the accordion tube to the rim of the tube that is in contact with the skin surrounding the orifice of the ureteral tract.

[0022] The CSC of the PCC is composed of a flexible material coated on one side by a sticky, adhesive material coating layer. The CSC is structured as an elongated and flat sheet with a hole at its center. Typically the flat sheet has a "T" configuration. Alternatively, each of two or more connection-sheet-components has a spatial configuration that is part of a segmented-dome structure configuration with a hole at its dorsal ("top") side that is formed when all the sheets are placed one beside the other. The circumference of the rim of the hole fits in its dimension to surround the rim of the hollow-dome of the GPSC.

[0023] Each CSPC of the PCC is constructed of a sheet made of a flexible material that reversibly connects to the sticky coating layer side of a CSC and is peeled off from the CSC when the device of the present invention is deployed.

[0024] Reference is presently made to the deployment procedure of a device of the present invention:

[0025] The GPSC and the URC are connected to form a TCC. The connection is done by inserting the first tube of the URC through the dome of the GPSC. With the components connected, the GPSC is positioned over the glans penis of the treated patient and is pressed in the proximal direction so as to come into contact with the skin. The segmented-dome of the GPSC fits around the glans penis and stabilizes the TCC in its glans-penis contacted position. The proximal side of the URC of the TCC reversibly comes into contact with the skin that surrounds the orifice of the urethral tract of the treated patient. The URC, with its "spring-like" characteristics, softens the urine leak free tight contact-connection between the component and the sensitive skin of the glans penis.

[0026] The CSC of the PCC, after the removal of the CSPC, wraps around the GPSC and reversibly connects in an adjustable connection, by the sticky adhesive material layer, the TCC to the glans penis of the treated patient. The adhesive connection of the CSC to the glans penis anchors, stabilizes and fixates the GPSC in its position. The wrapping around of the GPSC by the CSC and the ability to choose the connection position of the CSC to the glans penis, enables the adjustments of the tightness of the contact-connection of the URC to the skin surrounding the orifice of the ureteral tract of a treated patient. The CSC is/are simply and easily connected, disconnected and again connected to the glans penis of a treated patient in accordance with changes in the posture of the patient and changes in urine discharge (pressure and amount) from the treated patient.

[0027] The easy and simple ability to adjust the tightness of the connection by the CSC (by the patient himself or by a care giver) together with the "spring-like" characteristics of the URC, minimizes the discomfort caused to a treated patient when applying the external urinary incontinence device of the present invention to the body of the patient.

[0028]

#### BRIEF DESCRIPTION OF THE DRAWINGS

[0029] In order to better understand the present invention, and appreciate its practical applications, the following Figures are provided and referenced hereafter. It should be noted

that the Figures are given as examples only and in no way limit the scope of the invention.

Like components are denoted by like reference numerals.

[0030] Fig. 1 is an isometric from-above-and-side view of an illustration of an embodiment of an external urinary incontinence treatment device of the present invention, with the tube connector component and the penis connection component of the device, disassembled.

[0031] Fig. 1A is an isometric from-above-and-side view of an illustration of the tube connector component illustrated in Fig. 1 disassembled to a urine receiving component and a glans penis stabilizing component.

[0032] Fig. 2 is an isometric from-above-and-side view of an illustration of the embodiment of the external urinary incontinence treatment device illustrated in Fig. 1 in an assembled configuration.

[0033] Fig. 3 is an isometric from-above-and-side view of an illustration of a second embodiment of an external urinary incontinence treatment device of the present invention, with the tube connector component and the penis connection component of the device, disassembled.

[0034] Fig. 3A is an isometric from-above-and-side view of an illustration of the tube connector component illustrated in Fig. 3 disassembled to a urine receiving component and a glans penis stabilizing component.

[0035] Fig. 4 is an isometric from-above-and-side view of an illustration of the external urinary incontinence treatment device illustrated in Fig. 3, with the components of the device assembled.

[0036] Fig 5A up to and including 5C are cross cut side-view illustration of consecutive stages of contact-connecting a urine receiving component of the an external urinary incontinence treatment device of the present invention to the skin of the glans penis of a treated patient.

[0037] Fig. 6A up to and including Fig. 6F, are illustrations of consecutive stages of deploying the external urinary incontinence treatment device of the present invention, illustrated in Fig. 1 and Fig. 2.

[0038] Fig. 7 is an illustration of the external urinary incontinence treatment device of the present invention illustrated in Fig. 3 and Fig. 4 in the final stage of deployment, connected to a urine removal tube.

## DETAILED DESCRIPTION OF A PREFERRED EMBODIMENTS

[0039] It should be clear that the description of the embodiment and attached Figures set forth in this specification serves only for a better understanding of the invention, without limiting its scope.

[0040] Two embodiments of the external urinary incontinence treatment device of the present invention are described. The first embodiment is illustrated in Fig. 1, Fig. 1A and Fig. 2, the second embodiment is illustrated in Fig. 3, Fig. 3A and Fig. 4. In the detailed description of the deployment of a device of the present invention, illustrated in Fig. 6A up to and including 6F, the first embodiment of the device of the present invention is shown. The same consecutive stages of deployment illustrated in the figures are relevant for the second embodiment of a device of the present invention.

[0041] A device of the present invention (the two embodiments of the device are designated 10 and 11, respectively) is constructed of: a tube connector component (also referred to as TCC) (29) and a penis connection component (also referred to as: PCC) (23).

[0042] The TCC (29) is constructed of two connected components: a glans penis stabilization component (also referred to as GPSC) (16) and a urine receiving component (also referred to as: URC) (22). The PCC (23) is constructed of at least one connection-sheet-component (also referred to as: CSC) (12) having a sticky, adhesive material coated layer, side, and at least one connection-sheet-protection-component (also referred to as: CSPC) (14).

[0043] GPSC (16) is constructed of a hollow dome structure, referred to as cover-dome (19) with a hole at its dorsal ("top") side (20) and stabilizing-sheet-components (18) that are connected to, and extend radially from, the rim of the dome, at its proximal ("bottom") side. Stabilizing-sheet-components (18) are referred to interchangeably as: SSC Cover-dome (19) is made of a semi rigid material such as, but not limited to, silicone or rubber, or plastic. SSC (18) are structured as at least two sheets also made of semi-rigid flexible material such as, but not limited to, plastic, rubber or silicone. The SSC (18) are connected to cover-dome (19) in a configuration that forms a segmented dome connected to cover-dome (19), shown in Fig. 1A and Fig. 3A. In Fig. 1, two SSCs (18) are illustrated, in Fig. 3, three SSCs are

shown. The GPSC (16) is produced as a single-entity component, or, alternatively, cover-dome (19) and the SSC (18) are produced as separate entity components and are connected to form the TCC (29).

[0044] URC is constructed of a first tube (24), a dome structure that has a hollow and opened tube that runs through the dome structure and extended from the dome (26) and an accordion tube (28). Tube (24) has an opening hole (30) in its dorsal ("top") side to which a urine-removal-tube tube (31) reversibly connects and through which urine is flowed to a collecting vessel, typically, a urine collection bag (tube (31) shown in Fig. 6F). Tube (24) runs through the tube in dome (26) and connects to the dorsal side of the second tube (28). Tube (24) and tube (28) communicate freely. Dome (26) and tube (28) are structured in an "accordion dome" and "accordion tube" configuration, respectively. The components of the urine-receiving component (22) are made of semi-rigid material, such as, but not limited to, silicon and rubber, or plastic. Urine-receiving component (22) is produced as a single-entity component, or, alternatively, tube (24) dome (26) and tube (28) are produced as separate entity components and are connected to form the urine-receiving component (22).

[0045] The CSC (12) of PPC (23) is composed of at least one sheet made of flexible material such as, but not limited to, cloth or plastic or silicone. The sheet has a "sticky" side which is covered by a coating layer of an adhesive material and a plain, "not-sticky" side. The adhesive material can be spread directly on the surface of the sheet, or alternatively, the material is on a thin film that is connected to the surface of the sheet. The adhesive material is present on the surface of the sheet when the sheet is in storage, prior to deployment, or alternatively, the adhesive material is applied just prior to the deployment of the sheet.

[0046] In the embodiment (10) illustrated in Fig. 1 and Fig. 2, the CSC (12) is constructed of an elongated single sheet with a hole (21) in the middle. Typically, the elongated sheet has a rectangle configuration with two side protruding portions (27), bestowing a "T" shape configuration to the sheet.

[0047] In the embodiment (11) illustrated in Fig. 3 and Fig. 4, the CSCs (12) are constructed of at least two sheet-components with each component having a "slice-of-pie" configuration without the top, "sharp end", section of the slice. The CSCs also have a spatial concave configuration, When placed side by side the CSCs form a hollow sliced dome configuration with a hole at its dorsal top-side.

[0048] CSPC (14) is composed of at least one sheet made of a flexible material such as, but not limited to, paper or plastic, or silicon. Each individual CSPC reversibly covers and connects to the sticky side of an individual CSC. The CSPC preserve the stickiness of sticky side on the CSC and are removed from the CSC and discarded prior to the deployment of the device of the present invention.

[0049] Reference is presently made to the figures:

[0050] Fig. 1 illustrates an isometric from-above-and-side view of an embodiment (10) of an external urinary incontinence treatment device of the present invention, with the TCC (29) and the PCC (23) of the device, disassembled. Fig. 1A illustrates an isometric from-above-and-side view of the TCC (29) illustrated in Fig. 1, disassembled into the URC (22) and the GPSC (16). Fig. 2 illustrates an isometric from-above-and-side view of the embodiment (10) of the external urinary incontinence treatment device illustrated in Fig. 1 in an assembled configuration.

[0051] Fig. 3 illustrates an isometric from-above-and-side view of an embodiment (11) of an external urinary incontinence treatment device of the present invention, with the TCC (29) and the PCC (23) of the device, disassembled. Fig. 3A illustrates an isometric from-above-and-side view of the TCC (29) illustrated in Fig. 3 disassembled into the URC (22) and the GPSC (16). Fig. 4 illustrates an isometric from-above-and-side view of the embodiment (11) of the external urinary incontinence treatment device illustrated in Fig. 3 in an assembled configuration.

[0052] Figures 5A up to and including 5C are cross cut side-view illustration of consecutive stages of contact-connecting an URC (22) of the of an external urinary incontinence treatment device of the present invention (10, 11) to the skin of the glans penis (34) of a treated patient. The illustrations explain the "spring like" characteristics bestowed by the accordion configuration of the accordion dome (26) and accordion tube (28) to the URC (22).

[0053] Fig. 5A illustrates the formation of contact between the URC (22) and the skin surrounding the orifice of the urethral tract (36). Accordion tube (28) is illustrated in a slightly compressed configuration and accordion dome (26) is illustrated in a straight (not bent) configuration.

[0054] Fig. 5B illustrates the URC (22) in contact with the skin surrounding the orifice of the urethral tract (36). URC (22) is fixated its position with accordion tube (28) illustrated in a compressed configuration and accordion dome (26) illustrated in a straight (not bent) configuration.

[0055] Fig. 5C illustrates the URC (22) in contact with the skin surrounding the orifice of the urethral tract (36) and the tube (24) of the URC (22) connected by a urine-removing-tube (not shown in the figure) that leads to a urine collection vessel. URC (22) is fixated in its position with accordion tube (28) illustrated in a compressed configuration and accordion dome (26) is illustrated in a bent configuration. The bending is caused by the pull and weight of the urine-removing-tube (31) (tube shown in Fig 6F) .

[0056] In Fig. 6A up to and including Fig. 6F, the SSC (18) is/are illustrated contact-connected to skin of the glans penis (34), thus stabilizing the TCC (29) in its position over the orifice of the urethral tract and the proximal rim of the accordion tube (28) of URC (22) in contact with the skin surrounding the skin of the orifice of the urethral tract of the treated patient. The CSC (12) of the PCC (23) is/are illustrated warping over (contact-connected) the TCC (29) and reversibly connected (by an adhesive material connection) to the skin of the glans penis (34) of the patient, thus, anchoring, stabilizing and fixating TCC (29) in its position. By disconnecting the connection between CSC (12) and the glans penis (34) and again reconnecting in a different location on the glans penis (34), the tightness as well as the exact positioning of the contact-connection between tube (24) and the skin of the glans penis can be altered and adjusted.

[0057] Fig. 6A up to and including Fig. 6F, are illustrations of consecutive stages of deploying the external urinary incontinence treatment device (10).

[0058] Fig. 6A illustrates one hand (50) of the patient (or care giver) holding the GPSC (16) while the second hand (52) holding the URC (22). Tube (24) of the URC is placed in an aligned position with hole (20) in the GPSC (16). If the TCC (29) is produced so that the GPSC (16) and the URC (22) are connected to form a single entity component, the deployment of the device is initiated in the following stage, illustrated in Fig. 3B.

[0059] Fig. 6B illustrates the insertion of tube (24) of URC (22) into hole (20) in the GPSC (16), thus, the TCC (29) is connected to the PCC (23) in a "perpendicular configuration".

[0060] Fig. 6C illustrates the holding of the penis (32) by the treated patient (or care giver) by one hand (50) and placing with the other hand (52) the rim of accordion tube (28) of the URC (22) on the skin around the orifice of the urethral tract (36) (shown in Fig. 5A).

[0061] Fig. 6D illustrates the holding of the penis (32) by the treated patient (or care giver) by one hand (50) and with the other hand (52) the CSPC (14) is peeled off from the CSC (12) by pulling the margin of the CSPC (14) from the CSC (12).

[0062] Fig. 6E illustrates the GPSC (16) positioned over the glans penis (34), the URC (22) in contact-connection with the skin surrounding the orifice of the urethral tract of the treated patient (shown in Fig. 5A) and the sticky surface side of the CSC (12) exposed.

[0063] Fig. 6F illustrates the final stage of deploying of device (10). The sticky surface of the longitudinal edges of the CSC (12) are folded towards the glans penis (34) and reversibly connect to the circumference skin area beyond the GPSC (16) by the adhesive material. In following, protruding margins (27) of CSC (12) are wrapped around and reversibly connect with the adhesive material to the folded and connected longitudinal edges of the CSC (12) and to the still free skin areas of the glans penis (34). With the TCC (29) fixated in place, urine removing tube (31) is reversibly connected to hole (30) in tube (24).

[0064] Fig. 7 is an illustration of the second embodiment of the external urinary incontinence treatment device of the present invention (11) illustrated in Fig. 3 and Fig. 4. The device (11) is illustrated in the final stage of deployment, connected to a urine removal tube (31). In device (11), the TCC (29) is positioned over the glans penis (34), as illustrated in Fig. 6C for embodiment (10). The CSPCs (14) are individually peeled off from the CSC (12) by pulling the CSPCs from the CSCs, as shown for embodiment (10) in Fig. 6D. The exposed sticky sides of the CSCs (12) wrap around the GPSC (16) and reversibly connect to the skin surface of the glans penis (34) that is in the proximal circumference of the glans penis beyond the GPSC (16), as illustrated for embodiment (10) in Fig. 6F. To ensure the stability of the contact-connection of the TCC (29) to glans penis (34), the CSCs (12) overlap.

[0065] It should also be clear that a person skilled in the art, after reading the present specification could make adjustments or amendments to the attached Figures and above described embodiments that would still be covered by the present invention.

## CLAIMS

I claim:

- 1) An external urinary incontinence treatment device for a man patient that reversibly connects to a urine removing tube  
comprising:  
a tube connector component and  
a penis connection component,  
wherein, said tube connector component comprises:  
a glans penis stabilizing component and  
a urine receiving component,  
wherein, said glans penis stabilizing component is constructed of a hollow dome structure with a hole at the top of the dome and at least two stabilizing sheets connected to the circumference rim of the dome,  
wherein, said urine receiving component comprises:  
a first tube,  
a hollow dome with a hole at its top and  
a second tube,  
wherein said hollow dome of said urine receiving component has a hole at its top,  
wherein, said hollow dome and second tube of urine receiving component have a resilient accordion configuration,  
wherein said first tube of said urine receiving component is inserted through the hole in said hollow dome of the urine receiving component and connects and communicates freely with the second tube of said urine receiving component,  
wherein, said penis connection component comprises;  
at least one connection sheet component and  
at least one connection sheet protection component,  
wherein said connection sheet component of said penis connection component, has an adhesive material coated layer side,

wherein, said connection sheet protection component is connected to said an adhesive material coated layer side of said connection sheet component,

wherein said glans penis stabilizing component and said urine receiving component are connected by inserting said first tube of the urine receiving component into the hole in the a hollow dome structure of the a hollow dome structure of the glans penis stabilizing component,

wherein said tube connector component is positioned over the orifice of the urethral tract of said treated patient and the said stabilizing sheets contact of said glans penis stabilizing component contact connect to the skin of the glans penis of the treated patient,

wherein, the rim of said second tube of said urine receiving component is contact connected to the skin surrounding the orifice of the urethral tract of said treated patient,

wherein said connection sheet protection component of said penis connection component is peeled off said connection sheet component and the adhesive material coated layer side of the said connection sheet component wraps around said tube connector component and reversibly connects in an adjustable connection to the skin of the glans penis of said treated patient,

wherein, said reversible adjustable connection of said connection sheet protection component of said penis connection component to the skin of the glans penis of said treated patient, anchors, stabilizes and fixates said tube connector component in its position over said orifice of the urethral tract of said treated patient and contact connects the second tube of said urine receiving component to the skin surrounding the orifice of the urethral tract of said treated patient in a urine leak free connection that minimizes the discomfort caused to the treated patient,

wherein, the first tube of the said urine receiving component of said anchored, stabilized and fixated connector component reversibly connects to a urine removing tube.

- 2) The tube connector component of the external urinary incontinence treatment device of claim 1, wherein the glans penis stabilizing component and the urine receiving component of the tube connector component are produced as a single entity component.
- 3) The urine receiving component of the tube connector component of the external urinary incontinence treatment device of claim 1, wherein the first tube, the hollow dome and the second tube of the urine receiving component are produced as a single entity component.
- 4) The tube connector component of the external urinary incontinence treatment device of claim 1, wherein the tube connector component is produced of semi-rigid materials.

- 5) The penis connection component of the external urinary incontinence treatment device of claim 1, wherein the penis connection component is produced of sheets made of semi-rigid materials.
- 6) The wherein the connection sheet component of the penis connection component of the external urinary incontinence treatment device of claim 1, where the adhesive material coated layer side is coated by an adhesive material thin film that is connected to the surface of the connection sheet.
- 7) The stabilizing sheets of the glans penis stabilizing component of the tube connector component of the external urinary incontinence treatment device of claim 1, wherein the stabilizing sheets have a concaved configuration that forms a segmented-hollow-dome spatial structure.
- 8) The hollow dome and the second tube of the urine receiving component of the tube connector component of the external urinary incontinence treatment device of claim 1, wherein the resilient accordion configuration of the hollow dome and the second tube bestow a spring-like characteristics to the urine receiving component.
- 9) The connection sheet component of the penis connection component of the external urinary incontinence treatment device of claim 1, wherein the connection sheet component has an elongated and flat configuration.
- 10) The connection sheets component of the penis connection component of the external urinary incontinence treatment device of claim 1, wherein the connection sheets form a spatial structure configuration of a segmented dome.
- 11) A method for the treatment of urinary incontinence treatment of a man by deploying an external urinary incontinence treatment device,  
the device comprising:  
a tube connector component and a penis connection component,  
wherein, said tube connector component comprises:  
a glans penis stabilizing component and a urine receiving component,

wherein, said glans penis stabilizing component is constructed of a hollow dome structure with a hole at the top of the dome and at least two stabilizing sheets connected to the circumference rim of the dome,

wherein said urine receiving component comprises:

a first tube,

a hollow dome with a hole at its top and

a second tube,

wherein, said hollow dome of said urine receiving component has a hole at its top,

wherein, said hollow dome and second tube of urine receiving component have a resilient accordion configuration,

wherein said first tube of said urine receiving component is inserted through the hole in said hollow dome of the urine receiving component and connects and communicates freely with the second tube of said urine receiving component,

wherein, said penis connection component comprises;

at least one connection sheet component and

at least one connection sheet protection component,

wherein, said connection sheet component of said penis connection component, has an adhesive material coated layer side,

wherein, said connection sheet protection component is connected to said an adhesive material coated layer side of said connection sheet component,

wherein said glans penis stabilizing component and said urine receiving component are connected by inserting said first tube of the urine receiving component into the hole in the a hollow dome structure of the a hollow dome structure of the glans penis stabilizing component,

wherein said tube connector component is positioned over the orifice of the urethral tract of said treated patient and the said stabilizing sheets contact of said glans penis stabilizing component contact connect to the skin of the glans penis of the treated patient,

wherein, the rim of said second tube of said urine receiving component is contact connected to the skin surrounding the orifice of the urethral tract of said treated patient,

wherein said connection sheet protection component of said penis connection component is peeled off said connection sheet component and the adhesive material coated layer side of the said connection sheet component wraps around said tube connector component and

reversibly connects in an adjustable connection to the skin of the glans penis of said treated patient,

wherein said reversible adjustable connection of said connection sheet protection component of said penis connection component to the skin of the glans penis of said treated patient, anchors, stabilizes and fixates said tube connector component in its position over said orifice of the urethral tract of said treated patient and contact connects the second tube of said urine receiving component to the skin surrounding the orifice of the urethral tract of said treated patient in a urine leak free connection that minimizes the discomfort caused to the treated patient,

wherein, the first tube of the said urine receiving component of said anchored, stabilized and fixated connector component reversibly connects to a urine removing tube.

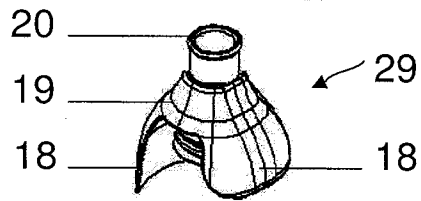
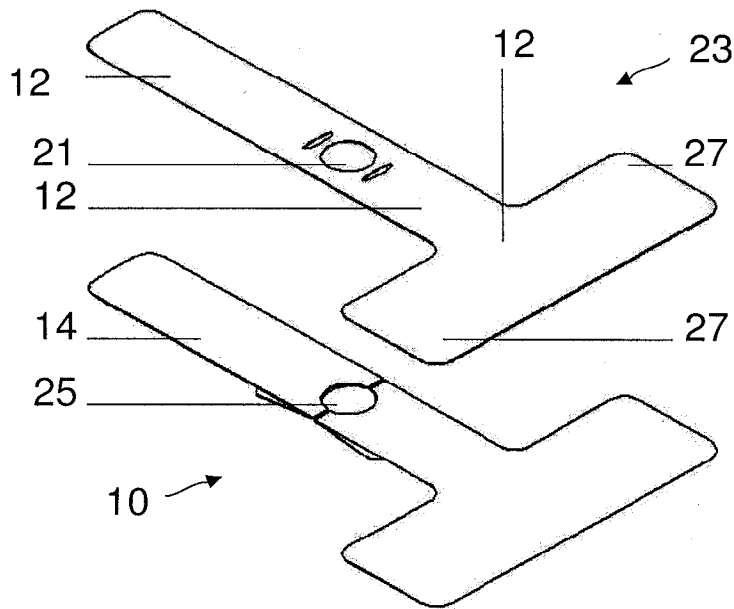

Fig. 1

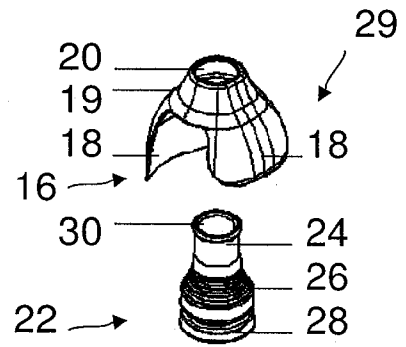

Fig. 1A

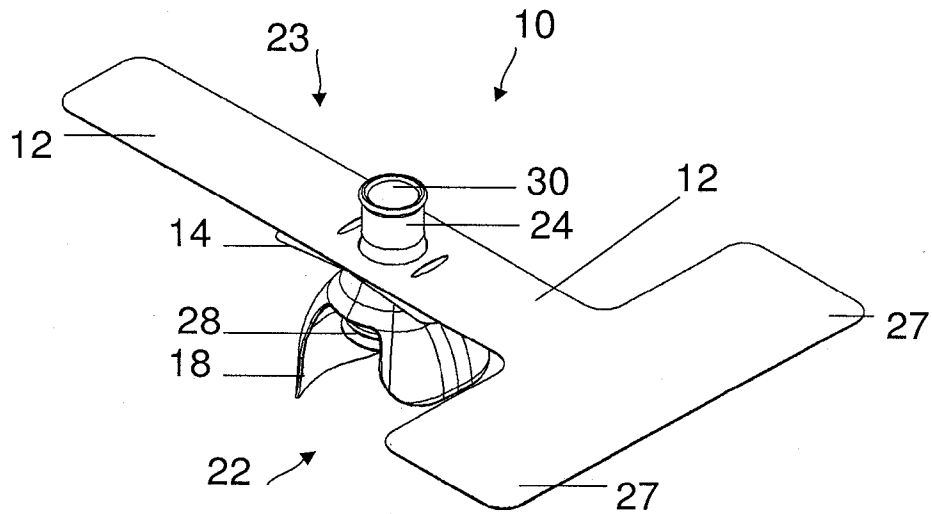

Fig. 2

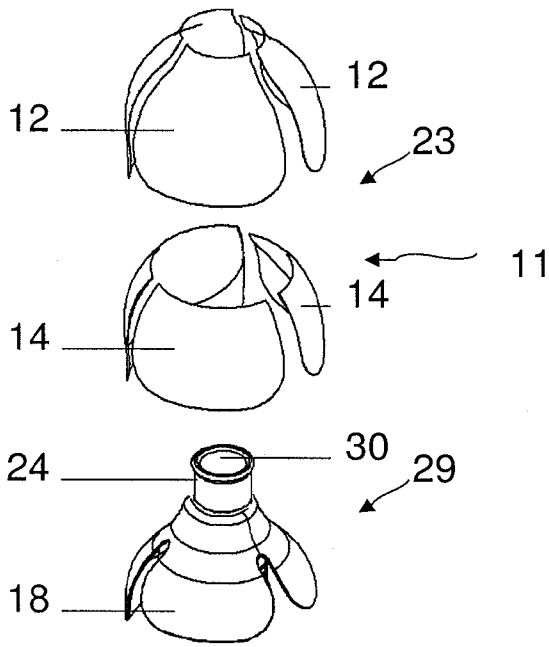

Fig. 3

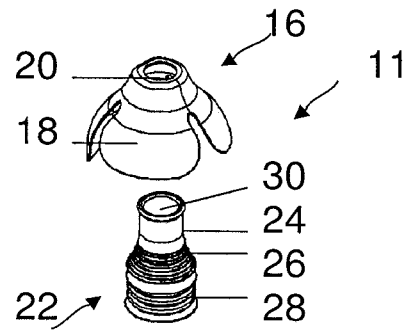

Fig. 3A

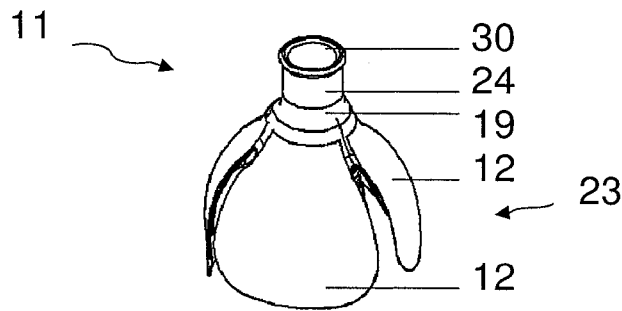
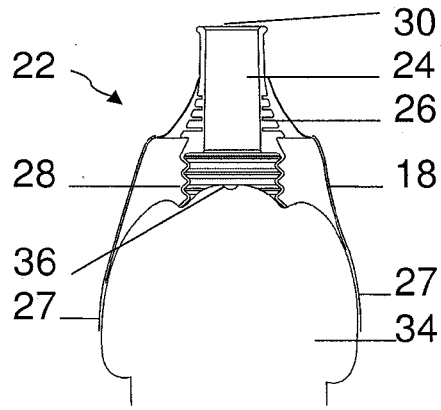
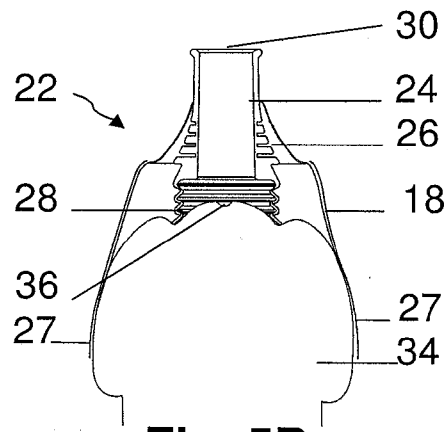

Fig. 4



**Fig. 5A**



**Fig. 5B**

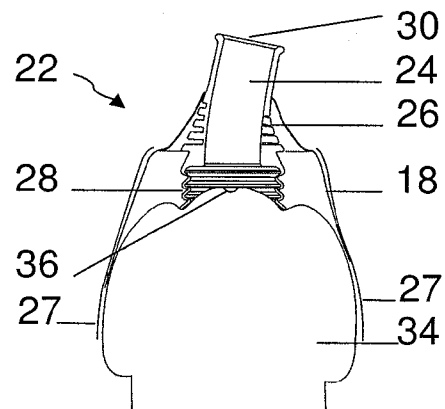

**Fig. 5C**

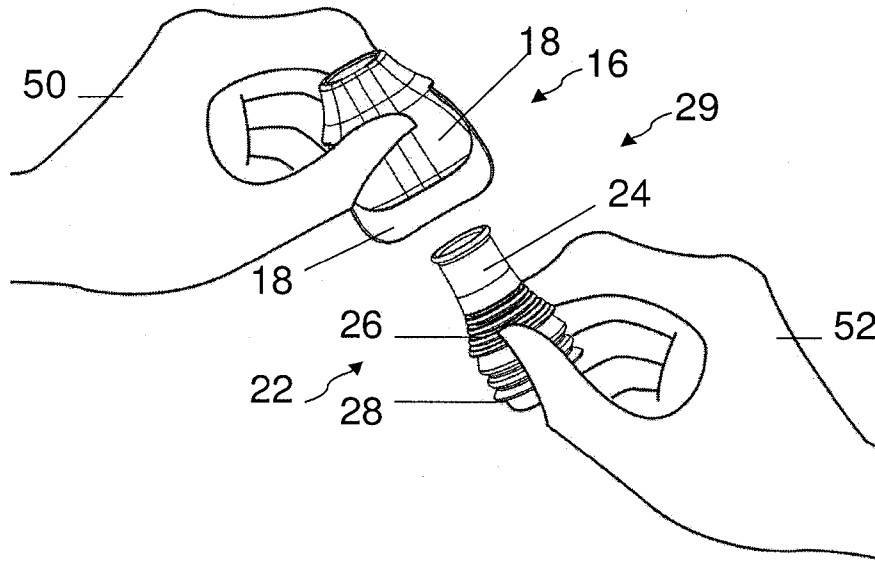

Fig. 6A

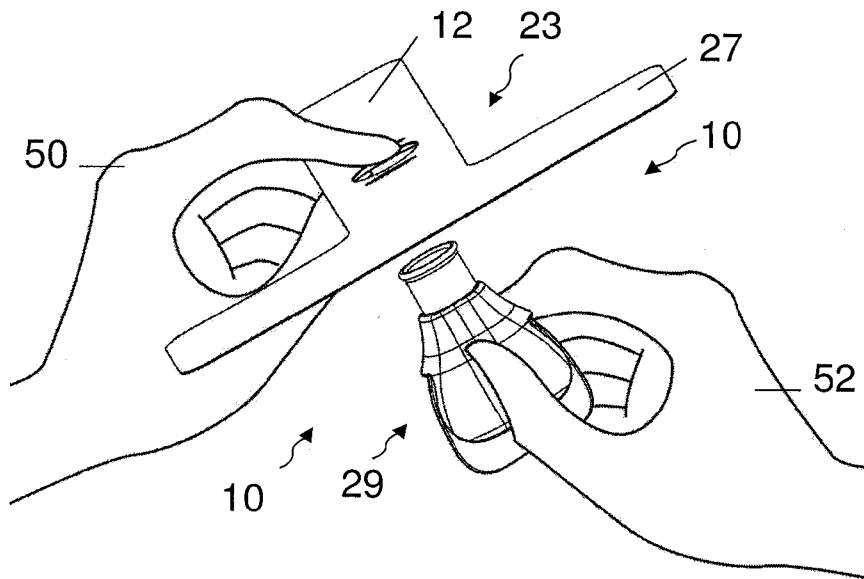
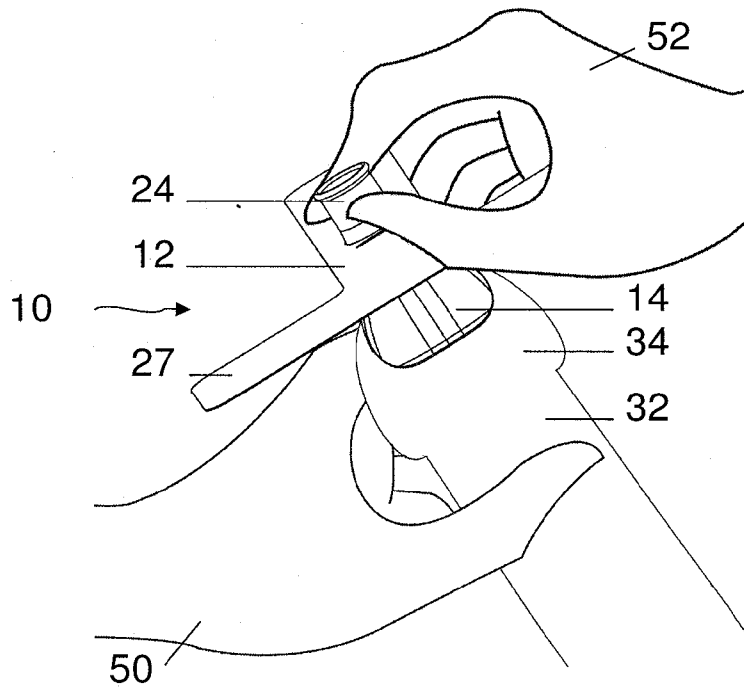
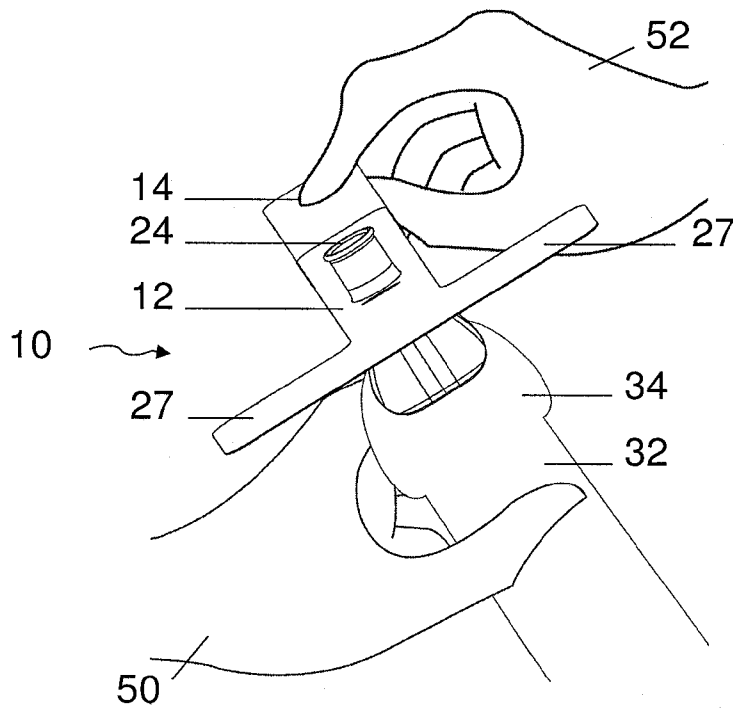

Fig. 6B



**Fig. 6C**



**Fig. 6D**

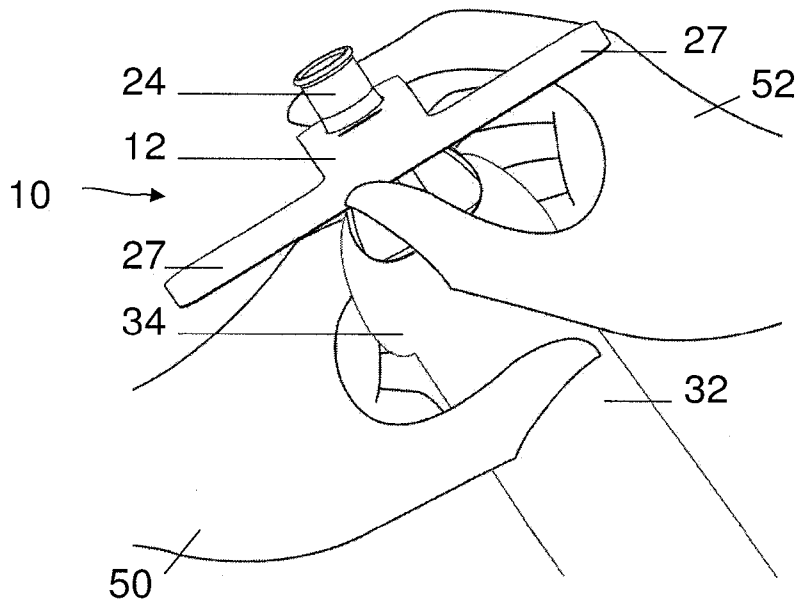

**Fig. 6E**

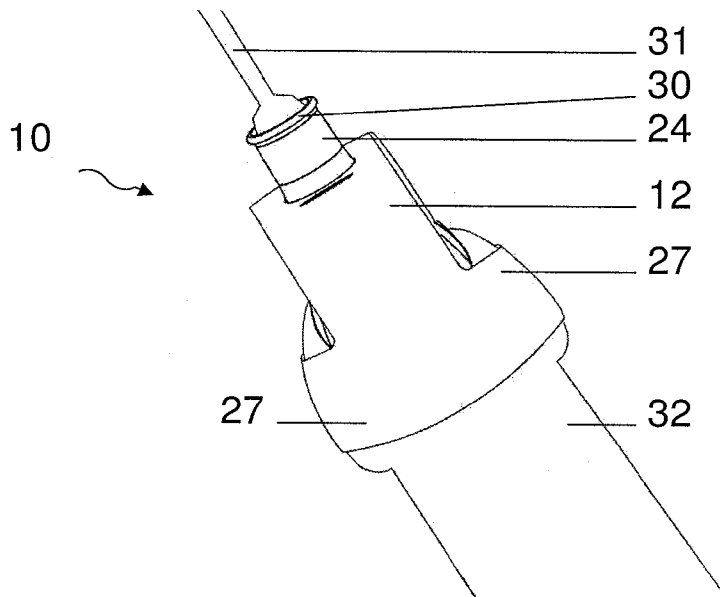

**Fig. 6F**

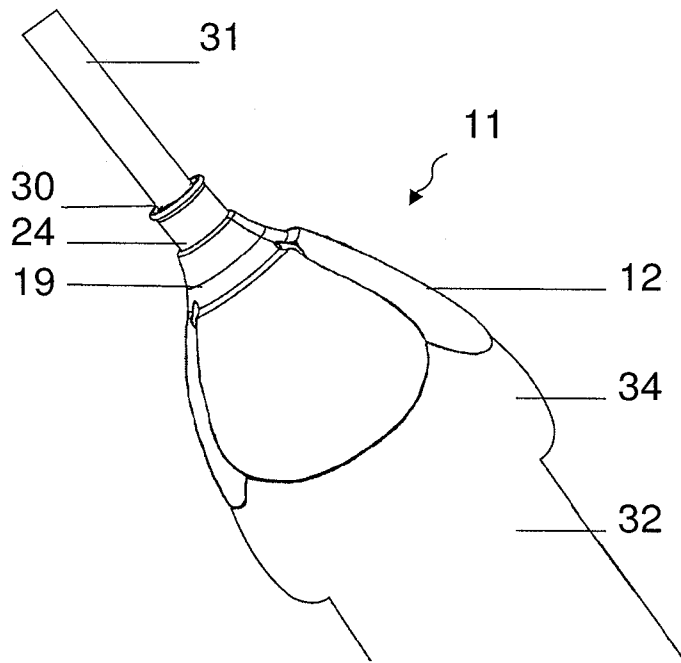

Fig. 7

**INTERNATIONAL SEARCH REPORT**

International application No.

PCT/IL2014/000066

**A. CLASSIFICATION OF SUBJECT MATTER**

IPC (2015.01) A61F 5/453, A61F 5/44

According to International Patent Classification (IPC) or to both national classification and IPC

**B. FIELDS SEARCHED**

Minimum documentation searched (classification system followed by classification symbols)

IPC (2015.01) A61F 5/453

Documentation searched other than minimum documentation to the extent that such documents are included in the fields searched

Electronic data base consulted during the international search (name of data base and, where practicable, search terms used)

Databases consulted: Esp@cenet, FamPat database

**C. DOCUMENTS CONSIDERED TO BE RELEVANT**

Category*	Citation of document, with indication, where appropriate, of the relevant passages	Relevant to claim No.
A	US 2011230851 A1 KAY DENNIS M; BIODERM, INC 22 Sep 2011 (2011/09/22) The whole document	1-11
A	US 2006122568 A1 LEADING EDGE INNOVATIONS, INC 08 Jun 2006 (2006/06/08) The whole document	1-11
A	US 6068618 A MEDPOINT CORPORATION 30 May 2000 (2000/05/30) The whole document	1-11
A	US 4957487 A BAYLOR COLLEGE OF MEDICINE 18 Sep 1990 (1990/09/18) The whole document	1-11
A	US 4581026 A HOLLISTER INCORPORATED 08 Apr 1986 (1986/04/08) The whole document	1-11

Further documents are listed in the continuation of Box C.

See patent family annex.

\* Special categories of cited documents:

“A” document defining the general state of the art which is not considered to be of particular relevance

“E” earlier application or patent but published on or after the international filing date

“L” document which may throw doubts on priority claim(s) or which is cited to establish the publication date of another citation or other special reason (as specified)

“O” document referring to an oral disclosure, use, exhibition or other means

“P” document published prior to the international filing date but later than the priority date claimed

“T” later document published after the international filing date or priority date and not in conflict with the application but cited to understand the principle or theory underlying the invention

“X” document of particular relevance; the claimed invention cannot be considered novel or cannot be considered to involve an inventive step when the document is taken alone

“Y” document of particular relevance; the claimed invention cannot be considered to involve an inventive step when the document is combined with one or more other such documents, such combination being obvious to a person skilled in the art

“&” document member of the same patent family

Date of the actual completion of the international search

21 Apr 2015

Date of mailing of the international search report

22 Apr 2015

Name and mailing address of the ISA:

Israel Patent Office  
Technology Park, Bldg.5, Malcha, Jerusalem, 9695101, Israel  
Facsimile No. 972-2-5651616

Authorized officer

BITTON Oren

Telephone No. 972-2-5657812

## INTERNATIONAL SEARCH REPORT

International application No.

PCT/IL2014/000066

C (Continuation). DOCUMENTS CONSIDERED TO BE RELEVANT		
Category*	Citation of document, with indication, where appropriate, of the relevant passages	Relevant to claim No.
A	US 2002087130 A1 GULDFELDT SIGNE UHRE; NIELSEN HENRIK LINDENSKOV; TANGHOJ ALLAN; COLOPLAST A/S 04 Jul 2002 (2002/07/04) The whole document	1-11
A	US 5380311 A SYNTHELABO 10 Jan 1995 (1995/01/10) The whole document	1-11
A	US 5197957 A COLOPLAST A/S 30 Mar 1993 (1993/03/30) The whole document	1-11
A	The whole document	1-11
A	US 4731064 A HEYDEN, EUGENE L 15 Mar 1988 (1988/03/15) The whole document	1-11
A	US 5334175 A ROCHESTER MEDICAL CORPORATION 02 Aug 1994 (1994/08/02) The whole document	1-11
A	US 4759753 A HOLLISTER INCORPORATED 26 Jul 1988 (1988/07/26) The whole document	1-11
A	US 5318551 A SYNTHELABO 07 Jun 1994 (1994/06/07) The whole document	1-11
A	US 5211640 A COLOPLAST A/S 18 May 2018 (2018/05/18) The whole document	1-11

**INTERNATIONAL SEARCH REPORT**  
Information on patent family members

International application No.  
PCT/IL2014/000066

Patent document cited search report	Publication date	Patent family member(s)	Publication Date
US 2011230851 A1	22 Sep 2011	US 2011230851 A1	22 Sep 2011
		US 8551062 B2	08 Oct 2013
		WO 2011028939 A1	10 Mar 2011
US 2006122568 A1	08 Jun 2006	US 2006122568 A1	08 Jun 2006
		US 7160277 B2	09 Jan 2007
		CA 2675598 A1	24 Jul 2008
		EP 2124853 A2	02 Dec 2009
		US 2005101924 A1	12 May 2005
		US 7166092 B2	23 Jan 2007
		US 2005101923 A1	12 May 2005
		US 2007117880 A1	24 May 2007
		WO 2008088911 A2	24 Jul 2008
		WO 2008088911 A3	16 Jul 2009
US 6068618 A	30 May 2000	US 6068618 A	30 May 2000
		US 5713880 A	03 Feb 1998
US 4957487 A	18 Sep 1990	US 4957487 A	18 Sep 1990
US 4581026 A	08 Apr 1986	US 4581026 A	08 Apr 1986
		AT A216782 A	15 Nov 1988
		AT 388289 B	26 May 1989
		AU 540628 B2	29 Nov 1984
		AU 8294282 A	09 Dec 1982
		CA 1176530 A1	23 Oct 1984
		DE 3220791 A1	30 Dec 1982
		DE 3220791 C2	05 Jan 1989
		DK 243682 A	06 Dec 1982
		DK 153814 B	12 Sep 1988
		DK 153814 C	27 Dec 1989

**INTERNATIONAL SEARCH REPORT**  
Information on patent family members

International application No.  
PCT/IL2014/000066

Patent document cited search report	Publication date	Patent family member(s)	Publication Date
		ES 270391 U	01 Sep 1983
		ES 270391 Y	16 Mar 1984
		ES 512602 D0	01 Jun 1983
		ES 8306643 A1	16 Sep 1983
		FR 2507081 A1	10 Dec 1982
		FR 2507081 B1	23 Sep 1988
		GB 2099706 A	15 Dec 1982
		GB 2099706 B	09 Jan 1985
		IE 820941 L	05 Dec 1982
		IE 52880 B1	30 Mar 1988
		IT 8248514 D0	26 May 1982
		IT 1148938 B	03 Dec 1986
		JP S581445 A	06 Jan 1983
		JP H0365976 B2	15 Oct 1991
		NL 8202283 A	03 Jan 1983
		NL 184870 B	03 Jul 1989
		NL 184870 C	01 Dec 1989
		SE 8203249 L	06 Dec 1982
		SE 456723 B	31 Oct 1988
		US 4626250 A	02 Dec 1986
<hr/>			
US 2002087130 A1	04 Jul 2002	US 2002087130 A1	04 Jul 2002
		US 6632204 B2	14 Oct 2003
		AT 354329 T	15 Mar 2007
		DE 60126822 D1	05 Apr 2007
		DE 60126822 T2	06 Dec 2007
		EP 1347723 A1	01 Oct 2003
		EP 1347723 B1	21 Feb 2007
		HU 0400965 A2	30 Aug 2004
		US 2004087921 A1	06 May 2004
		WO 02053070 A1	11 Jul 2002

**INTERNATIONAL SEARCH REPORT**  
Information on patent family members

International application No. PCT/IL2014/000066
----------------------------------------------------

Patent document cited search report	Publication date	Patent family member(s)	Publication Date
US 5380311 A	10 Jan 1995	US 5380311 A	10 Jan 1995
		AT 180162 T	15 Jun 1999
		DE 69324964 D1	24 Jun 1999
		EP 0580470 A1	26 Jan 1994
		EP 0580470 B1	19 May 1999
		FR 2693651 A1	21 Jan 1994
		FR 2693651 B1	14 Oct 1994
		JP H06154259 A	03 Jun 1994
US 5197957 A	30 Mar 1993	US 5197957 A	30 Mar 1993
		AT 127002 T	15 Sep 1995
		AU 2197192 A	25 Jan 1993
		DE 69204460 D1	05 Oct 1995
		DE 69204460 T2	07 Mar 1996
		DK 121791 D0	21 Jun 1991
		EP 0590104 A1	06 Apr 1994
		EP 0590104 B1	30 Aug 1995
		WO 9300054 A1	07 Jan 1993
US 4731064 A	15 Mar 1988	US 4731064 A	15 Mar 1988
		US 4865595 A	12 Sep 1989
US 5334175 A	02 Aug 1994	US 5334175 A	02 Aug 1994
		AU 659117 B2	11 May 1995
		AU 3330993 A	28 Jul 1993
		AU 9094091 A	11 Jun 1992
		CA 2095030 A1	10 May 1992
		CA 2095030 C	21 Oct 2003
		DE 69107470 D1	23 Mar 1995
		DE 69107470 T2	14 Sep 1995

**INTERNATIONAL SEARCH REPORT**  
Information on patent family members

International application No. PCT/IL2014/000066
----------------------------------------------------

Patent document cited search report	Publication date	Patent family member(s)	Publication Date
		EP 0556325 A1	25 Aug 1993
		EP 0556325 B1	15 Feb 1995
		JP H06501412 A	17 Feb 1994
		JP 3409070 B2	19 May 2003
		US 5176666 A	05 Jan 1993
		US 5376085 A	27 Dec 1994
		WO 9208426 A1	29 May 1992
		WO 9312741 A1	08 Jul 1993
<hr/>			
US 4759753 A	26 Jul 1988	US 4759753 A	26 Jul 1988
		AU 595407 B2	29 Mar 1990
		AU 8246487 A	16 Jun 1988
		BR 8706731 A	19 Jul 1988
		CA 1280048 C	12 Feb 1991
		DE 3741557 A1	23 Jun 1988
		DE 3741557 C2	25 Mar 1999
		FR 2608042 A1	17 Jun 1988
		FR 2608042 B1	01 Apr 1994
		GB 8727708 D0	31 Dec 1987
		GB 2198952 A	29 Jun 1988
		GB 2198952 B	09 Jan 1991
		IE 873191 L	12 Jun 1988
		IE 60542 B1	27 Jul 1994
		JP H0539524 U	28 May 1993
		JP H0742413 Y2	04 Oct 1995
		JP S63160648 A	04 Jul 1988
		ZA 8709168 A	03 Jun 1988
<hr/>			
US 5318551 A	07 Jun 1994	US 5318551 A	07 Jun 1994
		AT 140147 T	15 Jul 1996
		DE 69303543 D1	14 Aug 1996

**INTERNATIONAL SEARCH REPORT**  
Information on patent family members

International application No.  
PCT/IL2014/000066

Patent document cited search report	Publication date	Patent family member(s)	Publication Date
		DE 69303543 T2	23 Jan 1997
		DK 0569287 T3	25 Nov 1996
		EP 0569287 A1	10 Nov 1993
		EP 0569287 B1	10 Jul 1996
		ES 2091569 T3	01 Nov 1996
		FR 2690842 A1	12 Nov 1993
		FR 2690842 B1	01 Jul 1994
		JP H06133995 A	17 May 1994
US 5211640 A	18 May 2018	US 5211640 A	18 May 1993
		CA 2059836 A1	31 Jul 1992
		DE 4200288 A1	13 Aug 1992
		DE 4200288 C2	06 Jul 1995
		DK 16291 D0	30 Jan 1991
		DK 16291 A	31 Jul 1992
		DK 166123 B	15 Mar 1993
		DK 166123 C	09 Aug 1993
		GB 9200390 D0	26 Feb 1992
		GB 2252247 A	05 Aug 1992
		GB 2252247 B	01 Jun 1994