



(51) International Patent Classification:

A61M 5/315 (2006.01) A61M 5/31 (2006.01)  
A61M 5/178 (2006.01)

(21) International Application Number:

PCT/US2020/013420

(22) International Filing Date:

14 January 2020 (14.01.2020)

(25) Filing Language:

English

(26) Publication Language:

English

(30) Priority Data:

62/792,972 16 January 2019 (16.01.2019) US

(71) Applicant: **BELOTECA INVESTMENT FUND 1, LLC**  
[US/US]; 10525 Vista Sorrento Parkway, San Diego, CA  
92121 (US).

(72) Inventor: **KELLY, Lawrence J.**; 1934 Resor Road, Fair-  
field, OH 45014 (US).

(74) Agent: **GENDLOFF, Elie**; Gendloff IP, 1209 Stratton Dr.,  
Vista, CA 90283 (US).

(81) Designated States (unless otherwise indicated, for every  
kind of national protection available): AE, AG, AL, AM,

AO, AT, AU, AZ, BA, BB, BG, BH, BN, BR, BW, BY, BZ,  
CA, CH, CL, CN, CO, CR, CU, CZ, DE, DJ, DK, DM, DO,  
DZ, EC, EE, EG, ES, FI, GB, GD, GE, GH, GM, GT, HN,  
HR, HU, ID, IL, IN, IR, IS, JO, JP, KE, KG, KH, KN, KP,  
KR, KW, KZ, LA, LC, LK, LR, LS, LU, LY, MA, MD, ME,  
MG, MK, MN, MW, MX, MY, MZ, NA, NG, NI, NO, NZ,  
OM, PA, PE, PG, PH, PL, PT, QA, RO, RS, RU, RW, SA,  
SC, SD, SE, SG, SK, SL, ST, SV, SY, TH, TJ, TM, TN, TR,  
TT, TZ, UA, UG, US, UZ, VC, VN, WS, ZA, ZM, ZW.

(84) Designated States (unless otherwise indicated, for every  
kind of regional protection available): ARIPO (BW, GH,  
GM, KE, LR, LS, MW, MZ, NA, RW, SD, SL, ST, SZ, TZ,  
UG, ZM, ZW), Eurasian (AM, AZ, BY, KG, KZ, RU, TJ,  
TM), European (AL, AT, BE, BG, CH, CY, CZ, DE, DK,  
EE, ES, FI, FR, GB, GR, HR, HU, IE, IS, IT, LT, LU, LV,  
MC, MK, MT, NL, NO, PL, PT, RO, RS, SE, SI, SK, SM,  
TR), OAPI (BF, BJ, CF, CG, CI, CM, GA, GN, GQ, GW,  
KM, ML, MR, NE, SN, TD, TG).

Published:

— with international search report (Art. 21(3))

(54) Title: ADJUSTABLE DOSE DRUG DELIVERY SYSTEM

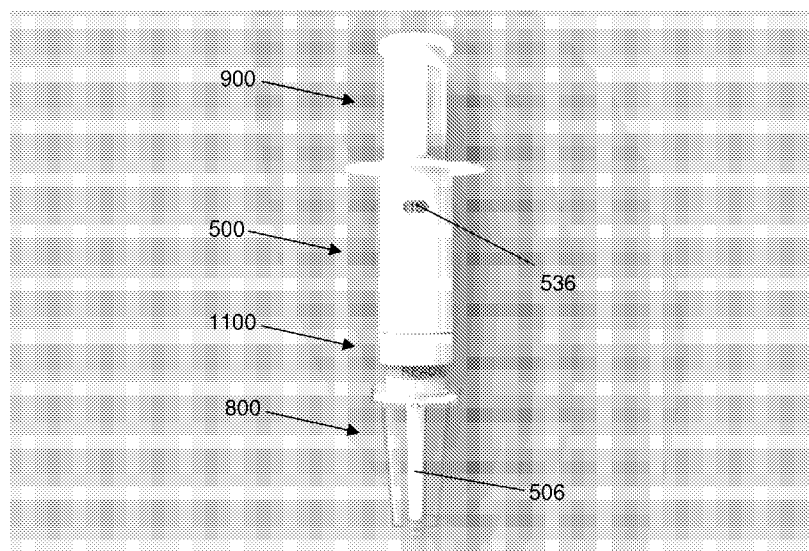

FIG. 1

(57) Abstract: A drug delivery system is provided that has an adjustable dose mechanism allowing setting and locking the dose then administration of the set dose. A method for administering a medicament using the drug delivery system is also provided.



## ADJUSTABLE DOSE DRUG DELIVERY SYSTEM

### 5 CROSS-REFERENCE TO RELATED APPLICATIONS

This application claims the benefit of U.S. Provisional Application No. 62/792,972, filed January 16, 2019, and incorporated by reference herein in its entirety.

### BACKGROUND OF THE INVENTION

#### (1) Field of the Invention

10 The present application generally relates to drug administration systems. More specifically, systems having an adjustable dose mechanism allowing setting and locking the dose then administration of the set dose.

#### (2) Description of the related art

15 A system for home administration of a drug has several preferred characteristics. The system should have simple, foolproof procedures for administering the drug. The system also preferably has a dosage adjustment mechanism that allows for the dosage to be set depending on the needs of the patient. The system can also have a mechanism allowing the set dosage to be locked, e.g., by a pharmacist. See US Patents 5,462,740; 5,578,011; 5,632,733; 6,090,077; 6,572,584; 7,329,241; and 7,351,224, and PCT Patent Publication WO 2018/085759.

20 Provided is a drug delivery system having the above characteristics.

### BRIEF SUMMARY OF THE INVENTION

Provided is an adjustable dose drug delivery system. The system comprises  
a plunger, a syringe body, an inner housing, an outer housing, a stop sleeve, and a lock  
25 collar, wherein

the plunger comprises a stopper at a plunger distal end, a plunger proximal end, and a  
plunger stem extending from the plunger distal end to the plunger proximal end;

the syringe body comprises a cylinder, and further comprises a syringe tip at a syringe body  
distal end and an open syringe body proximal end,

30 wherein the plunger is slidably deposited by inserting the stopper into the open  
proximal end of the syringe body and pushing the plunger flange toward the syringe body distal  
end;

the inner housing comprises a cylinder, and further comprises an inner housing proximal end and an inner housing distal end and substantially encloses the syringe body and is affixed thereto, wherein the inner housing further comprises

an upper flange below the engagement pits,

5 a lower flange between the upper flange and the inner housing distal end, with an inter-flange area between the upper flange and lower flange, and

an administration tip distal to the lower flange that is hollow and accommodates, at its proximal end, the syringe tip;

10 the outer housing comprises a cylinder that encompasses the inner housing from above the lower flange to above the mechanism that engages the stop sleeve, the outer housing further comprising an outer housing proximal end and an outer housing distal end, wherein the outer housing further comprises

an outer housing distal region adjacent to the inter-flange area of the inner housing, wherein the outer housing distal region

15 has a narrower circumference than the outer housing proximal end, and comprises a lock collar actuating mechanism that, when engaged, prevents rotation of the outer housing relative to the inner housing;

a dosage window displaying dosage information present on an outer surface of the stop sleeve; and

20 a stop sleeve engagement mechanism that engages the stop sleeve to prevent the stop sleeve from further movement when a designated dosage is dispensed;

the stop sleeve comprises a cylinder with a stop sleeve proximal end and a stop sleeve distal end, wherein the stop sleeve is disposed between the outer housing and the inner housing above the upper flange, the stop sleeve further comprising

25 a mechanism that engages the stop sleeve engagement mechanism on the outer housing, and

markings near the stop sleeve distal end indicating dosage settings; and

the lock collar encircles a portion of the outer housing distal region and engages with the lock collar actuating mechanism when the lock collar is slid toward the upper flange.

30

Also provided is a method of administering a medicament using the above adjustable dose drug delivery system. The method comprises

hold the outer housing proximal to the outer housing distal region, grasp the lower flange and turn the lower flange relative to the outer housing until a desired dosage is indicated in the dosage window;

slide the lock collar toward the upper flange to engage the lock collar actuating mechanism;

5 insert the administration tip into a bodily orifice of a patient in need of the medicament;

dispense the medicament through the administration tip by pushing the plunger toward the syringe body distal end until the plunger cannot be pushed any further.

#### BRIEF DESCRIPTION OF THE DRAWINGS

10 In accordance with the present invention,

FIG. 1 is a perspective view of an adjustable dose drug delivery system.

FIG. 2 is an exploded view of an adjustable dose drug delivery system.

FIG. 3 is a transparent view of a plunger inserted into a syringe body.

15 FIG. 4 is a perspective view of a syringe body with plunger inserted therein with an inner housing.

FIG. 5 is a transparent view of a syringe body and plunger inside an inner housing.

FIG. 6 is a transparent view of a syringe body and plunger inside an inner housing with a stop sleeve and snap top.

20 FIG. 7 is a transparent view of a syringe body, plunger, inner housing, stop sleeve, snap top and outer housing.

FIG. 8 is a transparent view of a syringe body, plunger, inner housing, stop sleeve, snap top and outer housing, with an exploded view of a lock collar.

FIG. 9 is a transparent view of a syringe body, plunger, inner housing, stop sleeve, snap top, outer housing and lock collar.

25 FIG. 10 is a transparent view of a syringe body, plunger, inner housing, stop sleeve, snap top, outer housing, lock collar and seal pin.

FIG. 11 is a transparent view of a syringe body, plunger, inner housing, stop sleeve, snap top, outer housing, lock collar and protective cap.

30 FIG. 12 is a close-up transparent view of the distal portion of an outer housing and an inner housing, with a lock collar, seal pin and protective cap.

FIG. 13 is a close-up view of the distal portion of an outer housing, with a lock collar and protective cap.

FIG. 14 is a perspective view of the inside of a half of an outer housing with a lock collar half.

FIG. 15 is a perspective view of the inside of a half of an outer housing with a lock collar half.

5 FIG. 16 is a perspective view of a protective cap, snap top, stop sleeve and inner housing with a cutaway of an outer housing.

FIG. 17 is a closeup of a stop sleeve, snap top and a portion of an inner housing.

FIG. 18 is a closeup of a protective cap with a portion of the inside of an outer housing with a lock collar half.

10 FIG. 19 is a cutaway of an outer housing over an inner housing.

#### DETAILED DESCRIPTION OF THE INVENTION

As used herein, the singular forms "a", "an" and "the" are intended to include the plural forms as well, unless the context clearly indicates otherwise. Additionally, the use of "or" is  
15 intended to include "and/or", unless the context clearly indicates otherwise.

As used herein, "distal" is toward the end of the administrative tip; "proximal" is toward the portion of the plunger that is furthest from the stopper.

20 Provided is an adjustable dose drug delivery system. The system comprises a plunger, a syringe body, an inner housing, an outer housing, a stop sleeve, and a lock collar, wherein

the plunger comprises a stopper at a plunger distal end, a plunger proximal end, and a plunger stem extending from the plunger distal end to the plunger proximal end;

25 the syringe body comprises a cylinder, and further comprises a syringe tip at a syringe body distal end and an open syringe body proximal end comprising a syringe body flange,

wherein the plunger is slidably deposited by inserting the stopper into the open proximal end of the syringe body and pushing the plunger flange toward the syringe body distal end;

30 the inner housing comprises a cylinder, and further comprises an inner housing proximal end and an inner housing distal end and substantially encloses the syringe body, wherein the inner housing further comprises

an inner housing portion of a mechanism that engages the inner housing and stop sleeve to limit movement of the stop sleeve after the plunger is pushed toward the syringe body distal end in accordance with a dosage setting;

5 an upper flange below the mechanism that engages the inner housing and stop sleeve,

a lower flange between the upper flange and the inner housing distal end, with an inter-flange area between the upper flange and lower flange, and

an administration tip distal to the lower flange that is hollow and accommodates, at its proximal end, the syringe tip;

10 the outer housing comprises a cylinder that encompasses the inner housing from above the lower flange to above the mechanism that engages the stop sleeve, the outer housing further comprising an outer housing proximal end and an outer housing distal end, wherein the outer housing further comprises

15 an outer housing distal region adjacent to the inter-flange area of the inner housing, wherein the outer housing distal region

has a narrower circumference than the outer housing proximal end, and

comprises a lock collar actuating mechanism that, when engaged, prevents rotation of the outer housing relative to the inner housing;

20 a dosage window displaying dosage information present on an outer surface of the stop sleeve; and

a stop sleeve engagement mechanism that engages the stop sleeve to prevent the stop sleeve from further movement when a designated dosage is dispensed;

25 the stop sleeve comprises a cylinder with a stop sleeve proximal end and a stop sleeve distal end, wherein the stop sleeve is disposed between the outer housing and the inner housing above the upper flange, the stop sleeve further comprising

a stop sleeve portion of a mechanism that engages the inner housing and stop sleeve;

a mechanism that engages the stop sleeve engagement mechanism on the outer housing, and

30 markings near the stop sleeve distal end indicating dosage settings; and

the lock collar encircles a portion of the outer housing distal region and engages with the lock collar actuating mechanism when the lock collar is slid toward the upper flange.

Various nonlimiting embodiments of the system are depicted in the figures. One such embodiment is depicted in FIG. 1, showing a stop sleeve 900, an outer housing 500, a lock collar 1100, a protective cap 800 that protects an administration tip 506 when the system is not in use, and a dosage window 536.

5 An exploded illustration of the system, FIG. 2, reveals additional features and relationships between features. A snap top 1000 may be joined to a plunger 100 to provide comfortable support for a finger or thumb to administer a medicament by pushing the plunger toward the distal end of the inside of a syringe body 200. In some embodiments, the snap top 1000 is originally separated from the plunger in order to slide the stop sleeve 900 over the plunger 100 during manufacture of  
10 the system. In other embodiments, the snap top is integrated with the plunger at manufacture. The outer housing 500 envelops the inner housing 300, which has the administration tip 506 at its distal end, which may be covered with the protective cap 800. In various embodiments, a channel extending through the length of the administration tip 506, through which a medicament is administered, has a seal pin 1200 inserted therein when the system is not in use. The distal region  
15 of the outer housing 546 is enveloped by the lock collar 1100.

Where it may be convenient, any of the parts of the system may be manufactured in parts (e.g., in halves), as shown with the outer housing 500 and the lock collar 1100, which can be assembled during production of the system.

FIG. 3 provides details of a plunger 100 and syringe body 200 featured in some  
20 embodiments of the invention. The illustrated plunger 100 comprises a stopper 102 at its distal end, a plunger stem 104, a plunger flange 204, and a cap connector 100. The cap connector 100 is designed to couple with a snap cap 1000 and rest on the plunger flange 204 when the snap cap 1000 is snapped onto the cap connector 100. The interior of the syringe body 200 can hold a medicament before administration. The distal end of the syringe body 200 has a syringe tip 202,  
25 through which a substance (e.g., a medicament) in the syringe body 200 is dispensed into the administration tip 318 when the plunger 100 is pushed through the syringe body 200. The proximal end of the syringe body 200 has a syringe body flange 204, and a syringe body tab 206. These features engage the inner housing as described below.

The interaction of the syringe body 200 with the inner housing 300 is shown in FIG. 4 and  
30 FIG. 5. The illustrated embodiment shows an inner housing 300 having a lower flange 324 with lower flange indentations 334 that engages the protective cap 800 to retain the protective cap 800 on the lower flange 324 to protect the administration tip 318. The inner housing 300 also has an

upper flange **326**, an inter-flange area **328**, stop sleeve engagement rails **320** and a plurality of stop sleeve engagement pits **330** that are circumferentially and vertically deposited on the inner housing between the inner housing proximal end and the inner housing distal end, above the upper flange **326**. The functions of these external portions of the inner housing **300** are discussed below. The  
5 syringe body **200**, with a plunger **100** inserted therein, is deposited inside the inner housing **326** such that the inner housing **326** substantially encloses the syringe body **200**.

In the illustrated embodiments, the syringe body **200** is inserted into the inner housing **326** until an attachment tab **322** at the proximal end of the inner housing **300** engages a syringe body tab **206** at the proximal end of the syringe body **200**, joining the syringe body **200** with the inner  
10 housing **300** such that the proximal end of the inner housing **300** abuts the bottom of the syringe body flange **204**. There may be more than one (e.g., 2, 3 or 4) syringe body tab **206** and attachment tab **322**.

FIG. **6** shows the relationship of the inner housing **300** with the stop sleeve **900** in the illustrated embodiment. The stop sleeve **900** includes stop sleeve slots **906** comprising indentations  
15 in the stop sleeve, the stop sleeve slots **906** deposited at the stop sleeve distal end and extending toward the stop sleeve proximal end for varying distances depending on a specific dosage corresponding to each stop sleeve slot (further discussed below) **906**, and stop sleeve tongues **908**, at the end of each stop sleeve slot **906**. The stop sleeve tongue **908** has an inner knob **916** protruding inside of a distal end of the stop sleeve tongue **908** that engages the engagement pits **330** when the  
20 plunger **100** and stop sleeve **900** are pushed distally, limiting movement of the stop sleeve **900** toward the inner housing **300** proximal end. In some embodiments, the stop sleeve tongue **908** and engagement pits **330** are not present.

The stop sleeve **900** also has inner housing engagement guides **910** that engage the elevated stop sleeve engagement rails **320** to join the inner housing **300** with the stop sleeve **900** to rotate  
25 together. There may be more than one (e.g., 2, 3, or 4) set of inner housing engagement guides **910** and stop sleeve engagement rails **320** circumferentially deposited on the stop sleeve **900** and inner housing **300**.

The outer housing **500** and its relationship to the stop sleeve **900** and inner housing **300** is shown in FIG. **7**. In the illustrated embodiment, the distal end of the outer housing **544** rests on the  
30 lower flange of the inner housing **324**. The outer housing distal region **546** is indented, forming an outer housing ridge **522** on its proximal edge, and comprises at least one outer housing flap **514** comprising a lock collar engagement tab **516**, a lock collar guide rail **518**, which are components

that engage the lock collar **1100**. The illustrated outer housing has an outer housing flange **524** at its proximal end, which provides a finger hold when a medicament is administered by pushing on the snap top **1000** in a distal direction, which also moves the stop sleeve **900**, and the plunger **100** distally. In some embodiments, a stop sleeve tongue **908** and engagement pits **330** are present. In those embodiments, the stop sleeve tongue **908** sequentially engages the engagement pits **330** through its inner knob **916**, preventing proximal movement of the stop sleeve **900**, and the plunger **100** and snap top **1000** joined thereto.

**FIG. 8** and **FIG. 9** show the lock collar **1100** of the illustrated embodiment, and its engagement with the outer housing distal region **546**. The lock collar **1100** can be manufactured in halves **1102**, which are joined during assembly of the system. In some embodiments, the lock collar halves **1102** have lock collar assembly pegs **1104** which are inserted into lock collar assembly holes **1106** during assembly. Before use, the lock collar **1100** encircles the distal portion of the outer housing distal region **546**. After the dosage is set, by turning the outer housing **500** relative to the stop sleeve **900** until the designated dosage, as indicated by the dosage marking **912** on a distal portion of the stop sleeve **900**, as shown in **FIG. 17**, appears in the dosage window **536** of the outer housing **500**, as shown in **FIG. 14**, the dosage setting is locked by sliding the lock collar **1100** to the outer housing ridge **522** until a lock collar upper shelf **1108**, on the inside of the lock collar **1100** engages the lock collar engagement tab **516** on the outer housing flap **514**. The lock collar lower shelf **1110**, distal to the lock collar upper shelf **1108**, then rests on the lock collar guide rail **518** on the outer housing **500**. When the lock collar **1100** is so engaged, a lock collar engagement tab **516** on the inside of the outer housing **500**, as shown in **FIG. 14**, is pushed inwardly to cause the outer housing flap inner tab **526**, as shown in **FIGS. 12, 14, and 15**, to interfere with the rotation of the outer housing **500** relative to the inner housing **300** by entering a gap in the dosage lock railing **336** of the inner housing **300**, as shown in **FIG. 16** and **FIG. 19**.

**FIG. 10** and **FIG. 11** illustrate aspects of the distal portion of an embodiment of the system, showing the seal pin top **1202** at the dispensing hole **332** at the distal point of the administration tip **318**. The lower flange **324** has indentations **334** that match indentations **808** in the cap connector **806** at the proximal end of the protective cap **802**, such that the protective cap **800** stays on the lower flange **324** until manually removed.

**FIG. 12** shows the distal portion of the system in transparent view before engaging the lock collar **1100**, further showing the relationship between various parts, including the upper flange **326**, the lower flange **324**, the lock collar engagement tab **516**, the outer housing flap inner tab

**526**, the lock collar upper shelf **1108**, the lock collar lower shelf **1110**, the protective cap **800**, the cap connector **806**, the syringe tip **202**, the administration tip **318**, the dispensing hole **332**, the seal pin top **1202**, and the seal pin stem **1204**.

The distal portion of the system after the lock collar **1100** is engaged is shown in FIG. **13**,  
5 showing, *inter alia*, the protective cap **800**, with its cap connector **806** and cap connector indentations **808**.

FIG. **14** and FIG. **15** show two halves of the outer housing **500**, outer housing half A **528**,  
and outer housing half B **530**. The outer housing **500** may be constructed in parts, e.g., halves, as  
illustrated, for example with assembly holds **532** and assembly pegs **534** and outer housing  
10 assembly alignment ridges **540**, the latter feature used to ultrasonically “weld” the two outer  
housing halves **528**, **530** together. The outer housing rotation tabs **520** interacts with the inner  
housing rotation tab **340**, shown in FIG. **16**, to allow the inner housing **300** to turn 180 degrees to  
set the doses.

The dosage setting mechanism is shown in FIG. **14**, FIG. **15** and FIG. **16**, the latter figure  
15 showing the system with part of the outer housing **500** omitted. As previously discussed, the  
dosage is set by turning the outer housing **500** relative to the stop sleeve **900** until the designated  
dosage, as indicated by the dosage marking **912** on a distal portion of the stop sleeve **900**, as shown  
in FIG. **17**, appears in the dosage window **536** of the outer housing half A **528**. This aligns the stop  
sleeve slot **906** corresponding to the set dosage with the stop sleeve slot engagement ridge **538** on  
20 outer housing half B **530**. When the plunger **100** is pushed distally along with the stop sleeve **900**,  
the stop sleeve **900** travels along the inside of the outer housing **500**, the stop sleeve slot **906**  
corresponding to the set dosage traveling along outer housing half B **530** until the stop sleeve slot  
proximal end **914** abuts against the stop sleeve slot engagement ridge **538**, preventing further distal  
movement, and causing the administration of the precise dosage that was set. A closeup view of  
25 relevant features at the proximal portion of the system is shown in FIG. **17**, including the dosage  
marking **912** on the stop sleeve, and the stop sleeve slot proximal end **914**. The stop sleeve tongue  
**908**, the stop sleeve tongue inner knob **916** and the stop sleeve tongue engagement pits **330** are  
also shown, which are present in some embodiments, and prevent movement of the plunger **100**  
and stop sleeve **900** in the proximal direction, as previously discussed.

30 Additional views of various features of the illustrated embodiments described above are  
shown in FIG. **18** and FIG. **19**.

Although the illustrated embodiments provide for a long administration tip **318**, which is particularly suitable for rectal administration, the system of the present invention is also suitable to be used with needles, where a needle is utilized instead of the administration tip **318**. The needle could be used for any administration that uses a needle, e.g., intravenous, subdermal, intramuscular, intraperitoneal, etc., as those administration means are known in the art.

In certain specific embodiments, the drug delivery system has an administration tip suitable for rectal administration, e.g., administration tip **318**, and the drug is a benzodiazepine, for example diazepam. Such a system is suitable for treatment of, e.g., epilepsy.

Also provided is a method of administering a medicament using the above adjustable dose drug delivery system. The method comprises

hold the outer housing proximal to the outer housing distal region, grasp the lower flange and turn the lower flange relative to the outer housing until a desired dosage is indicated in the dosage window;

slide the lock collar toward the upper flange to engage the lock collar actuating mechanism;

insert the administration tip into a bodily orifice of a patient in need of the medicament;

dispense the medicament through the administration tip by pushing the plunger toward the syringe body distal end until the plunger cannot be pushed any further.

In some of these embodiments, the method further comprises

after dispensing the medicament,

pull the plunger in a proximal direction until the plunger is removed from the syringe body;

replace the plunger into the syringe body and push the plunger toward the syringe body distal end until all of the medicament is dispensed through the administration tip.

In some of these methods, the medicament is benzodiazepine and the bodily orifice is a rectal opening.

In certain of these embodiments, the turning of the lower flange relative to the outer housing and the sliding of the lock collar toward the upper flange is performed by a pharmacist who is not the patient.

In additional embodiments of these methods, the adjustable dose drug delivery system further comprises the seal pin inserted into the administration tip and the protective cap,

the lower flange is grasped and turned by grasping and turning the administration tip, and

the protective cap and the seal pin is removed before the administration tip is inserted into a bodily orifice of the patient.

In specific embodiments as illustrated in the figures, an adjustable dose drug delivery system is provided. The system comprises

a plunger, a syringe body, an inner housing, an outer housing, a stop sleeve, a lock collar, a seal pin, and a protective cap, wherein

5 the plunger comprises a stopper at a plunger distal end, a plunger proximal end, and a plunger stem extending from the plunger distal end to the plunger proximal end, the plunger proximal end further comprises a cap connector and a snap top, wherein

the snap top is a disk with a central fastener that joins with the cap connector to affix the snap top to the plunger proximal end;

10 the syringe body comprises a cylinder, and further comprises a syringe tip at a syringe body distal end and an open syringe body proximal end comprising a syringe body flange,

wherein the plunger is slidably deposited by inserting the stopper into the open proximal end of the syringe body and pushing the plunger flange toward the syringe body distal end;

15 the inner housing comprises a cylinder, and further comprises an inner housing proximal end and an inner housing distal end and encloses the syringe body and is affixed thereto, wherein the inner housing further comprises

an upper flange below the engagement pits,

20 a lower flange between the upper flange and the inner housing distal end, with an inter-flange area between the upper flange and lower flange, and

an administration tip distal to the lower flange that is hollow and accommodates, at its proximal end, the syringe tip;

25 the outer housing comprises a cylinder that encompasses the inner housing from above the lower flange to above the mechanism that engages the stop sleeve, the outer housing further comprising an outer housing proximal end, an outer housing distal end, wherein the outer housing further comprises

an outer housing distal region adjacent to the inter-flange area of the inner housing, wherein the outer housing distal region

has a narrower circumference than the outer housing proximal end, and

30 comprises a lock collar actuating mechanism that, when engaged, prevents rotation of the outer housing relative to the inner housing;

a dosage window displaying dosage information present on an outer surface of the stop sleeve; and

the stop sleeve comprises a cylinder with a stop sleeve proximal end and a stop sleeve distal end, wherein the stop sleeve is deposited between the outer housing and the inner housing above the upper flange,

the stop sleeve further comprising

markings near the stop sleeve distal end indicating dosage settings;

a plurality of stop sleeve slots comprising indentations in the stop sleeve, the stop sleeve slots deposited at the stop sleeve distal end and extending toward the stop sleeve proximal end for varying distances depending on a specific dosage corresponding to each stop sleeve slot; and

a stop sleeve slot engagement ridge protruding from an inside surface of the outer housing, wherein the stop sleeve slot engagement ridge engages with a stop sleeve slot proximal end to limit movement of the stop sleeve and attached plunger in accordance with the dosage setting;

the lock collar encircles a portion of the outer housing distal region and engages with the lock collar actuating mechanism when the lock collar is slid toward the upper flange,

wherein the lock collar actuating mechanism comprises

an outer housing flap in the outer housing distal region, the outer housing flap further comprising (a) a lock collar engagement tab the protrudes outward on the outer housing flap, and (b) an outer housing flap inner tab protruding from an inside surface of the outer housing flap;

a lock collar upper shelf comprising a ledge protruding from an inside of the lock collar on a proximal area of the lock collar; and

a dosage lock railing comprising a ledge protruding from a proximal area of the inter-flange area of the inner housing, wherein the dosage lock railing has a gap that accommodates the outer housing flap inner tab, wherein

when the lock collar is slid toward the upper flange, the ledge of the lock collar upper shelf pushes the lock collar engagement tab, directing the outer housing flap inwardly, which causes the outer housing flap inner tab to enter the gap in the dosage lock railing, preventing rotation of the outer housing relative to the inner housing;

the seal pin comprises

a seal pin stem comprising a long, thin needle that can be inserted into the administration tip hollow portion through a dispensing hole at a distal end of the administration tip; and

5 a seal pin top at a distal end of the seal pin stem, wherein the seal pin top prevents complete insertion of the seal pin into the administration tip; and

the protective cap encloses the administration tip and is affixed to the lower flange,

the adjustable dose drug delivery system further comprising:

components joining the inner housing and the stop sleeve to rotate together, comprising

10 a stop sleeve engagement rail comprising an elevated rail on the inner housing that substantially extends from the inner housing upper flange to the inner housing proximal end; and

an inner housing engagement guide comprising a protruding area at the stop sleeve distal end that accommodates the stop sleeve engagement rail;

15 a lock collar lower shelf comprising a ledge protruding from an inside of the lock collar on a distal area of the lock collar; and

a lock collar guide rail comprising a ledge in the outer housing distal region, wherein

the lock collar lower shelf rests on the lock collar guide rail prior to engagement of the lock collar actuating mechanism,

wherein

20 the dosage is set by turning the outer housing relative to the stop sleeve, inner housing, syringe body and plunger until a desired dosage marked on the stop sleeve is indicated in the dosage window;

the dosage setting is locked by sliding the lock collar toward the upper flange until the lock collar actuating mechanism is engaged; and

25 the set dosage of a substance present in the syringe body is expelled through a dispensing hole at a distal end of the administration tip.

Also provided is a method of administering a medicament using the adjustable dose drug delivery system as described immediately above and as illustrated in the figures. The method comprises

30 hold the outer housing proximal to the outer housing distal region, grasp the protective cap and turn the protective cap relative to the outer housing until a desired dosage is indicated in the dosage window;

slide the lock collar toward the upper flange to engage the lock collar actuating mechanism;  
remove (a) the protective cap from the lower flange, and (b) the seal pin from the  
administration tip;

5     insert the administration tip into a bodily orifice of a patient in need of the medicament;  
and

dispense the medicament through the administration tip by pushing the plunger toward the  
syringe body distal end until the plunger cannot be pushed any further.

10     In various embodiments, the method further comprises, after dispensing the medicament,  
pull the plunger in a proximal direction until the plunger is removed from the syringe body;  
and

replace the plunger into the syringe body and push plunger toward the syringe body distal  
end until all of the medicament is dispensed through the administration tip.

In certain embodiments of this method, the medicament is benzodiazepine and the bodily  
orifice is a rectal opening.

15     In other embodiments, the turning of the protective cap relative to the outer housing and  
the sliding of the lock collar toward the upper flange is performed by a pharmacist who is not the  
patient.

20     In view of the above, it will be seen that several objectives of the invention are achieved  
and other advantages attained.

As various changes could be made in the above methods and compositions without  
departing from the scope of the invention, it is intended that all matter contained in the above  
description and shown in the accompanying drawings shall be interpreted as illustrative and not in  
a limiting sense.

25     All references cited in this specification are hereby incorporated by reference. The  
discussion of the references herein is intended merely to summarize the assertions made by the  
authors and no admission is made that any reference constitutes prior art. Applicants reserve the  
right to challenge the accuracy and pertinence of the cited references.

What is claimed is:

1. An adjustable dose drug delivery system comprising:

a plunger, a syringe body, an inner housing, an outer housing, a stop sleeve, and a lock collar, wherein

the plunger comprises a stopper at a plunger distal end, a plunger proximal end, and a plunger stem extending from the plunger distal end to the plunger proximal end;

the syringe body comprises a cylinder, and further comprises a syringe tip at a syringe body distal end and an open syringe body proximal end,

wherein the plunger is slidably deposited by inserting the stopper into the open proximal end of the syringe body and pushing the plunger flange toward the syringe body distal end;

the inner housing comprises a cylinder, and further comprises an inner housing proximal end and an inner housing distal end and substantially encloses the syringe body, wherein the inner housing further comprises

an inner housing portion of a mechanism that engages the inner housing and stop sleeve to limit movement of the stop sleeve after the plunger is pushed toward the syringe body distal end in accordance with a dosage setting;

an upper flange below the mechanism that engages the inner housing and stop sleeve,

a lower flange between the upper flange and the inner housing distal end, with an inter-flange area between the upper flange and lower flange, and

an administration tip distal to the lower flange that is hollow and accommodates, at its proximal end, the syringe tip;

the outer housing comprises a cylinder that encompasses the inner housing from above the lower flange to above the mechanism that engages the stop sleeve, the outer housing further comprising an outer housing proximal end and an outer housing distal end, wherein the outer housing further comprises

an outer housing distal region adjacent to the inter-flange area of the inner housing, wherein the outer housing distal region

has a narrower circumference than the outer housing proximal end, and comprises a lock collar actuating mechanism that, when engaged, prevents rotation of the outer housing relative to the inner housing; and

a dosage window displaying dosage information present on an outer surface of the stop sleeve;

the stop sleeve comprises a cylinder with a stop sleeve proximal end and a stop sleeve distal end, wherein the stop sleeve is deposed between the outer housing and the inner housing above the upper flange, the stop sleeve further comprising

a stop sleeve portion of a mechanism that engages the inner housing and stop sleeve; and

markings near the stop sleeve distal end indicating dosage settings; and

the lock collar encircles a portion of the outer housing distal region and engages with the lock collar actuating mechanism when the lock collar is slid toward the upper flange.

2. The adjustable dose drug delivery system of claim 1, wherein

the dosage is set by turning the outer housing relative to the stop sleeve, inner housing, syringe body and plunger until a desired dosage marked on the stop sleeve is indicated in the dosage window;

the dosage setting is locked by sliding the lock collar toward the upper flange until the lock collar actuating mechanism is engaged; and

the set dosage of a substance present in the syringe body is expelled through a dispensing hole at a distal end of the administration tip.

3. The adjustable dose drug delivery system of claim 1, wherein

the mechanism that engages the stop sleeve and outer housing to limit movement of the plunger in accordance with a dosage setting comprises

a plurality of stop sleeve slots comprising indentations in the stop sleeve, the stop sleeve slots deposed at the stop sleeve distal end and extending toward the stop sleeve proximal end for varying distances depending on a specific dosage corresponding to each stop sleeve slot; and

a stop sleeve slot engagement ridge protruding from an inside surface of the outer housing, wherein the stop sleeve slot engagement ridge engages with a stop sleeve slot proximal end to limit movement of the stop sleeve and attached plunger in accordance with the dosage setting.

4. The adjustable dose drug delivery system of claim 1, wherein the mechanism that engages the inner housing and stop sleeve further comprises

a plurality of engagement pits circumferentially and vertically disposed on the inner housing between the inner housing proximal end and the inner housing distal end;

a stop sleeve tongue at a distal end of a stop sleeve slot formed by cutouts at each side of the stop sleeve slot; and

a stop sleeve tongue inner knob protruding inside of a distal end of the stop sleeve tongue, wherein the stop sleeve tongue inner knob engages an engagement pit to limit movement of the stop sleeve toward the inner housing proximal end.

5. The adjustable dose drug delivery system of claim 1, further comprising components joining the inner housing and the stop sleeve to rotate together.

6. The adjustable dose drug delivery system of claim 5, wherein the components joining the inner housing and the stop sleeve to rotate together comprise

a stop sleeve engagement rail comprising an elevated rail on the inner housing that substantially extends from the inner housing upper flange to the inner housing proximal end; and

an inner housing engagement guide comprising a protruding area at the stop sleeve distal end that accommodates the stop sleeve engagement rail.

7. The adjustable dose drug delivery system of claim 1, wherein the lock collar actuating mechanism comprises

an outer housing flap in the outer housing distal region, the outer housing flap further comprising (a) a lock collar engagement tab that protrudes outward on the outer housing flap, and (b) an outer housing flap inner tab protruding from an inside surface of the outer housing flap;

a lock collar upper shelf comprising a ledge protruding from an inside of the lock collar on a proximal area of the lock collar; and

a dosage lock railing comprising a ledge protruding from a proximal area of the inter-flange area of the inner housing, wherein the dosage lock railing has a gap that accommodates the outer housing flap inner tab, wherein

when the lock collar is slid toward the upper flange, the ledge of the lock collar upper shelf pushes the lock collar engagement tab, directing the outer housing flap inwardly, which causes the outer housing flap inner tab to enter the gap in the dosage lock railing, preventing rotation of the outer housing relative to the inner housing.

8. The adjustable dose drug delivery system of claim 7, further comprising a lock collar lower shelf comprising a ledge protruding from an inside of the lock collar on a distal area of the lock collar; and

a lock collar guide rail comprising a ledge in the outer housing distal region, wherein the lock collar lower shelf rests on the lock collar guide rail prior to engagement of the lock collar actuating mechanism.

9. The adjustable dose drug delivery system of claim 1, wherein the plunger proximal end further comprises a cap connector and a snap top, wherein

the snap top is a disk with a central fastener that joins with the cap connector to affix the snap top to the plunger proximal end.

10. The adjustable dose drug delivery system of claim 1, further comprising a seal pin, wherein the seal pin comprises

a seal pin stem comprising a long, thin needle that can be inserted into the administration tip hollow portion through a dispensing hole at a distal end of the administration tip; and

a seal pin top at a distal end of the seal pin stem, wherein the seal pin top prevents complete insertion of the seal pin into the administration tip.

11. The adjustable dose drug delivery system of claim 1, further comprising a protective cap that encloses the administration tip and is affixed to the lower flange.

12. The adjustable dose drug delivery system of claim 1, wherein the administration tip is suitable for rectal administration.

13. The adjustable dose drug delivery system of claim 1, wherein the syringe body comprises diazepam.

14. An adjustable dose drug delivery system comprising:

a plunger, a syringe body, an inner housing, an outer housing, a stop sleeve, a lock collar, a seal pin, and a protective cap, wherein

the plunger comprises a stopper at a plunger distal end, a plunger proximal end, and a plunger stem extending from the plunger distal end to the plunger proximal end, the plunger proximal end further comprises a cap connector and a snap top, wherein

the snap top is a disk with a central fastener that joins with the cap connector to affix the snap top to the plunger proximal end;

the syringe body comprises a cylinder, and further comprises a syringe tip at a syringe body distal end and an open syringe body proximal end comprising a syringe body flange,

wherein the plunger is slidably deposited by inserting the stopper into the open proximal end of the syringe body and pushing the plunger flange toward the syringe body distal end;

the inner housing comprises a cylinder, and further comprises an inner housing proximal end and an inner housing distal end and encloses the syringe body and is affixed thereto, wherein the inner housing further comprises

an upper flange,

a lower flange between the upper flange and the inner housing distal end, with an inter-flange area between the upper flange and lower flange, and

an administration tip distal to the lower flange that is hollow and accommodates, at its proximal end, the syringe tip;

the outer housing comprises a cylinder that encompasses the inner housing from above the lower flange to above the mechanism that engages the stop sleeve, the outer housing further comprising an outer housing proximal end, an outer housing distal end, wherein the outer housing further comprises

an outer housing distal region adjacent to the inter-flange area of the inner housing, wherein the outer housing distal region

has a narrower circumference than the outer housing proximal end, and

comprises a lock collar actuating mechanism that, when engaged, prevents rotation of the outer housing relative to the inner housing;

a dosage window displaying dosage information present on an outer surface of the stop sleeve; and

a stop sleeve engagement mechanism that engages the stop sleeve to prevent the stop sleeve from further movement when a designated dosage is dispensed;

the stop sleeve comprises a cylinder with a stop sleeve proximal end and a stop sleeve distal end, wherein the stop sleeve is deposited between the outer housing and the inner housing above the upper flange,

the stop sleeve further comprising

markings near the stop sleeve distal end indicating dosage settings;

a plurality of stop sleeve slots comprising indentations in the stop sleeve, the stop sleeve slots deposited at the stop sleeve distal end and extending toward the stop sleeve proximal end for varying distances depending on a specific dosage corresponding to each stop sleeve slot; and

a stop sleeve slot engagement ridge protruding from an inside surface of the outer housing, wherein the stop sleeve slot engagement ridge engages with a stop sleeve slot proximal end to limit movement of the stop sleeve and attached plunger in accordance with the dosage setting;

the lock collar encircles a portion of the outer housing distal region and engages with the lock collar actuating mechanism when the lock collar is slid toward the upper flange,

wherein the lock collar actuating mechanism comprises

an outer housing flap in the outer housing distal region, the outer housing flap further comprising (a) a lock collar engagement tab that protrudes outward on the outer housing flap, and (b) an outer housing flap inner tab protruding from an inside surface of the outer housing flap;

a lock collar upper shelf comprising a ledge protruding from an inside of the lock collar on a proximal area of the lock collar; and

a dosage lock railing comprising a ledge protruding from a proximal area of the inter-flange area of the inner housing, wherein the dosage lock railing has a gap that accommodates the outer housing flap inner tab, wherein

when the lock collar is slid toward the upper flange, the ledge of the lock collar upper shelf pushes the lock collar engagement tab, directing the outer housing flap inwardly, which causes the outer housing flap inner tab to enter the gap in the dosage lock railing, preventing rotation of the outer housing relative to the inner housing;

the seal pin comprises

a seal pin stem comprising a long, thin needle that can be inserted into the administration tip hollow portion through a dispensing hole at a distal end of the administration tip; and

a seal pin top at a distal end of the seal pin stem, wherein the seal pin top prevents complete insertion of the seal pin into the administration tip; and

the protective cap encloses the administration tip and is affixed to the lower flange,

the adjustable dose drug delivery system further comprising:

components joining the inner housing and the stop sleeve to rotate together, comprising

a stop sleeve engagement rail comprising an elevated rail on the inner housing that substantially extends from the inner housing upper flange to the inner housing proximal end; and

an inner housing engagement guide comprising a protruding area at the stop sleeve distal end that accommodates the stop sleeve engagement rail;

a lock collar lower shelf comprising a ledge protruding from an inside of the lock collar on a distal area of the lock collar; and

a lock collar guide rail comprising a ledge in the outer housing distal region, wherein

the lock collar lower shelf rests on the lock collar guide rail prior to engagement of the lock collar actuating mechanism,

wherein

the dosage is set by turning the outer housing relative to the stop sleeve, inner housing, syringe body and plunger until a desired dosage marked on the stop sleeve is indicated in the dosage window;

the dosage setting is locked by sliding the lock collar toward the upper flange until the lock collar actuating mechanism is engaged; and

the set dosage of a substance present in the syringe body is expelled through a dispensing hole at a distal end of the administration tip.

15. A method of administering a medicament using the adjustable dose drug delivery system of any one of claims 1-13, the method comprising

hold the outer housing proximal to the outer housing distal region, grasp the lower flange and turn the lower flange relative to the outer housing until a desired dosage is indicated in the dosage window;

slide the lock collar toward the upper flange to engage the lock collar actuating mechanism;

insert the administration tip into a bodily orifice of a patient in need of the medicament;  
dispense the medicament through the administration tip by pushing the plunger toward the syringe body distal end until the plunger cannot be pushed any further.

16. The method of claim 15, further comprising, after dispensing the medicament, pull the plunger in a proximal direction until the plunger is removed from the syringe body; replace the plunger into the syringe body and push the plunger toward the syringe body distal end until all of the medicament is dispensed through the administration tip.

17. The method of claim 15, wherein the medicament is benzodiazepine and the bodily orifice is a rectal opening.

18. The method of claim 15, wherein the turning of the lower flange relative to the outer housing and the sliding of the lock collar toward the upper flange is performed by a pharmacist who is not the patient.

19. The method of claim 15, wherein the adjustable dose drug delivery system further comprises the seal pin inserted into the administration tip and the protective cap, the lower flange is grasped and turned by grasping and turning the administration tip, and the protective cap and the seal pin is removed before the administration tip is inserted into a bodily orifice of the patient.

20. A method of administering a medicament using the adjustable dose drug delivery system of claim 14, the method comprising

hold the outer housing proximal to the outer housing distal region, grasp the protective cap and turn the protective cap relative to the outer housing until a desired dosage is indicated in the dosage window;

slide the lock collar toward the upper flange to engage the lock collar actuating mechanism;  
remove (a) the protective cap from the lower flange, and (b) the seal pin from the administration tip;

insert the administration tip into a bodily orifice of a patient in need of the medicament;  
and

dispense the medicament through the administration tip by pushing the plunger toward the syringe body distal end until the plunger cannot be pushed any further.

21. The method of claim 20, further comprising, after dispensing the medicament, pull the plunger in a proximal direction until the plunger is removed from the syringe body; and

replace the plunger into the syringe body and push plunger toward the syringe body distal end until all of the medicament is dispensed through the administration tip.

22. The method of claim 20, wherein the medicament is benzodiazepine and the bodily orifice is a rectal opening.

23. The method of claim 20, wherein the turning of the protective cap relative to the outer housing and the sliding of the lock collar toward the upper flange is performed by a pharmacist who is not the patient.

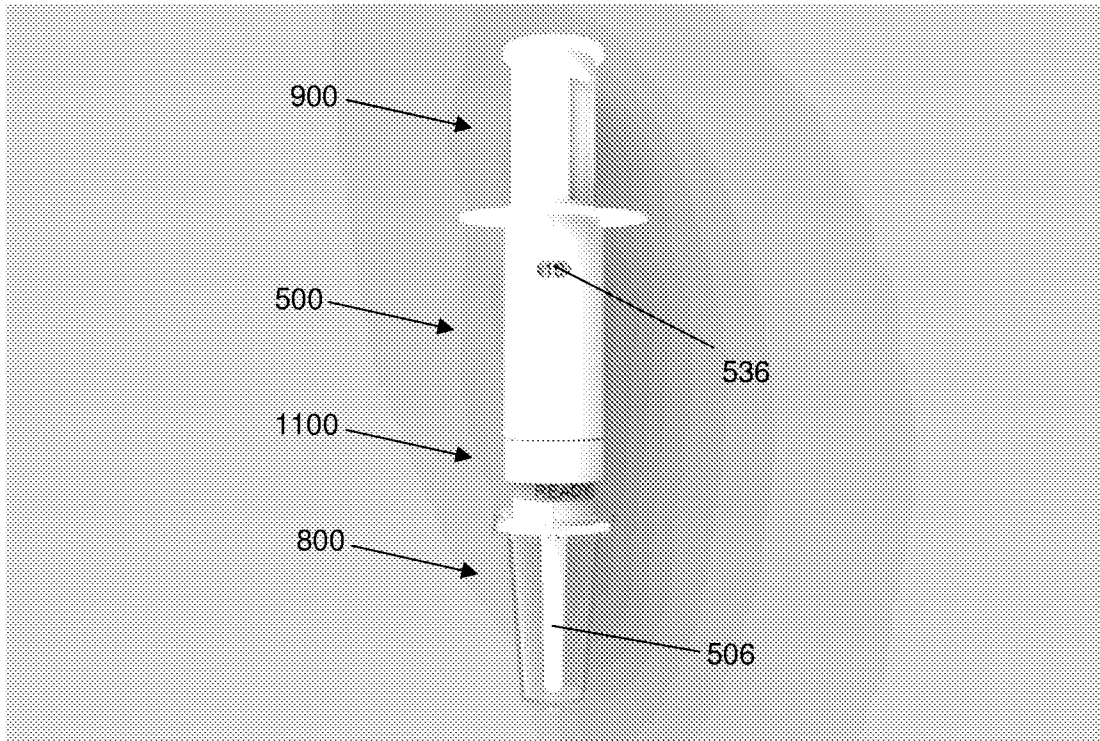

FIG. 1

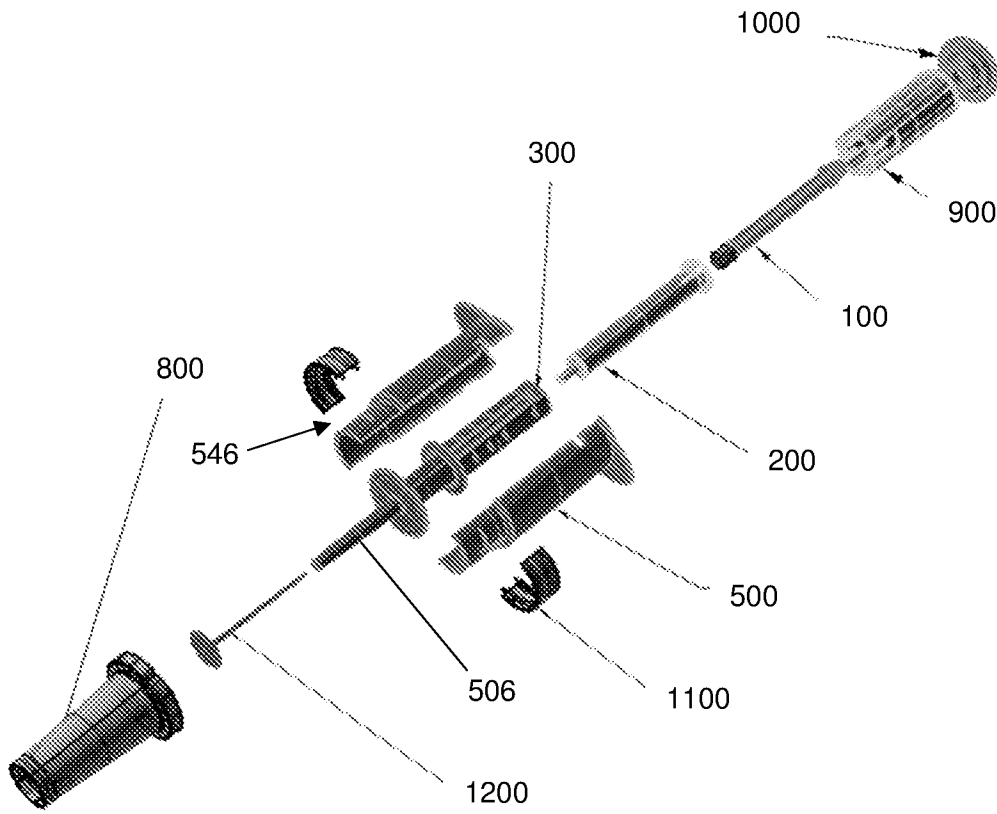

FIG. 2

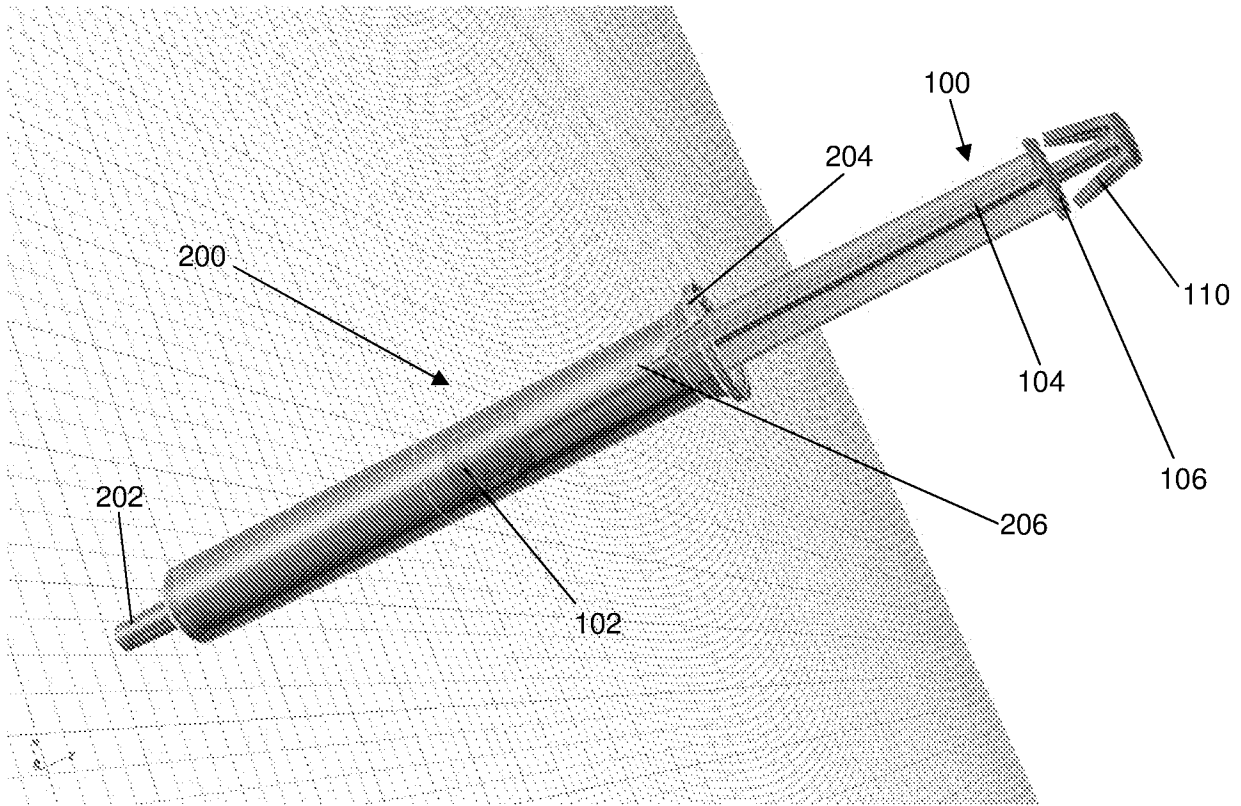

FIG. 3

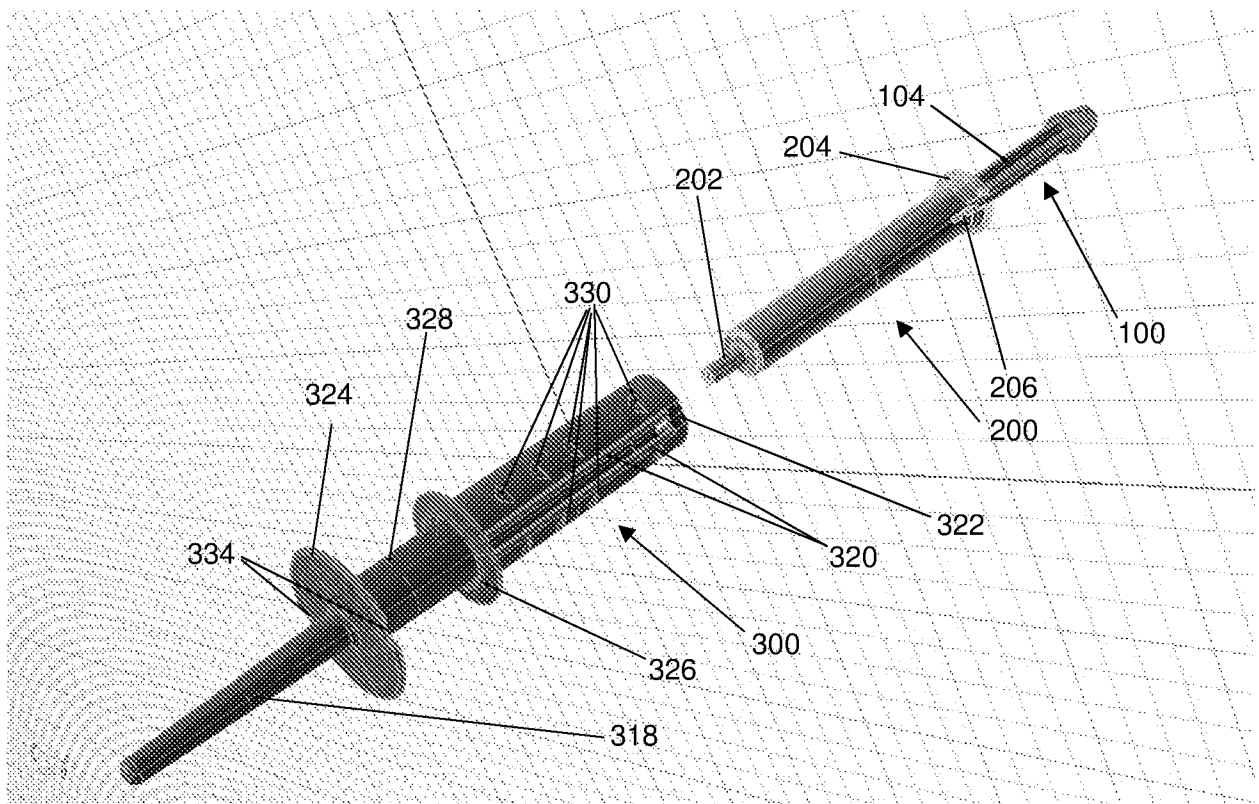

FIG. 4

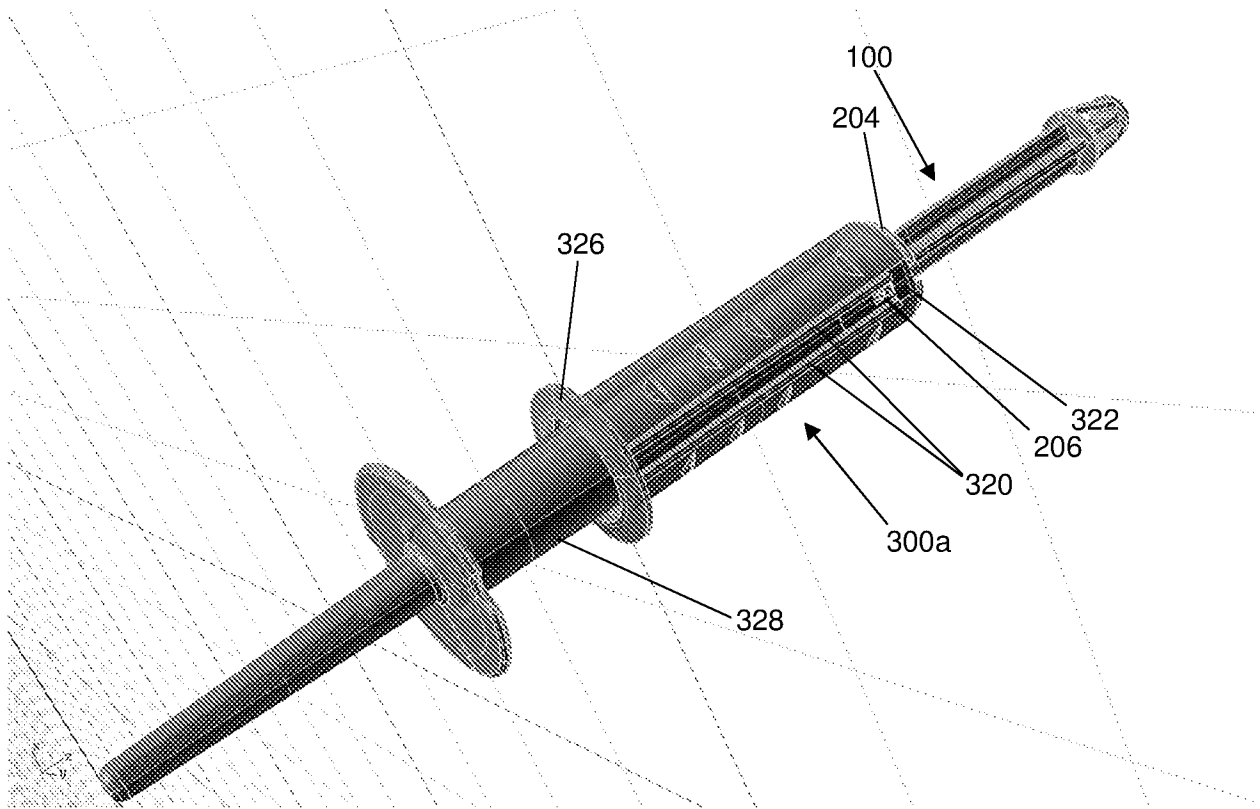

FIG. 5

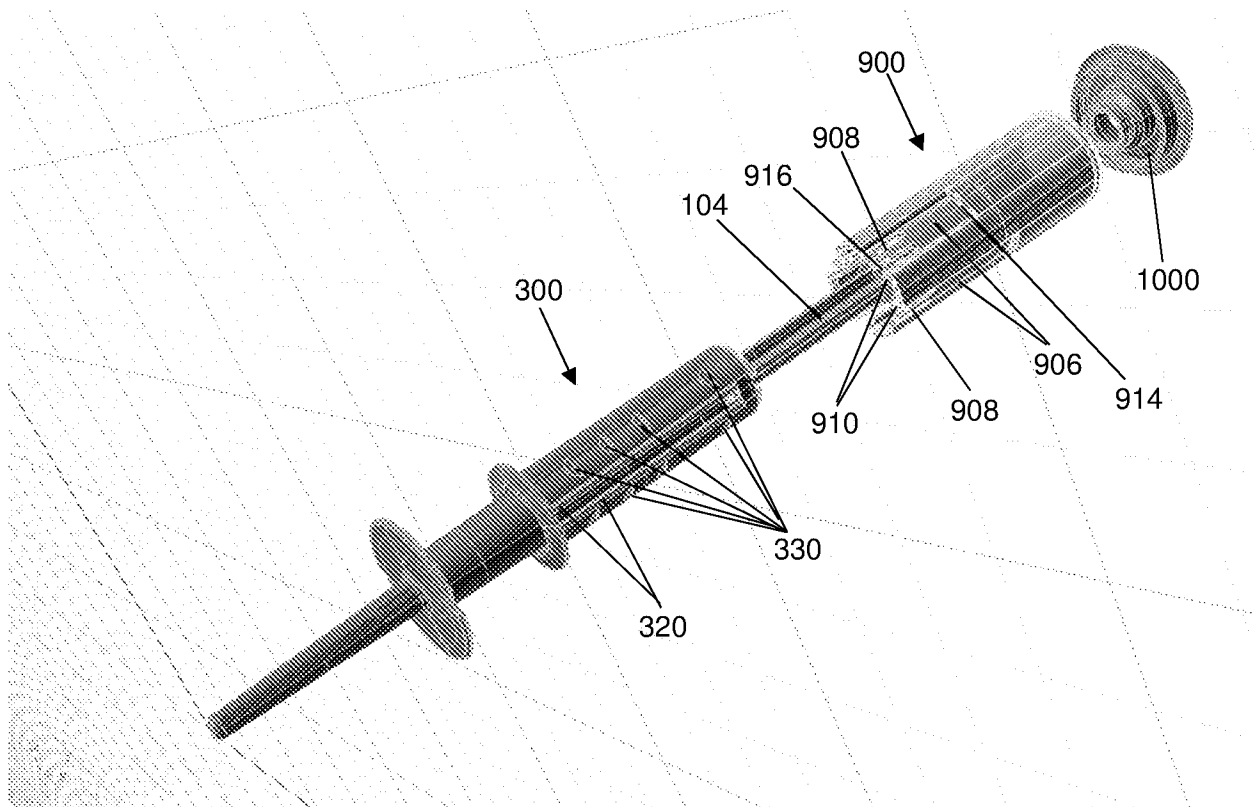

FIG. 6

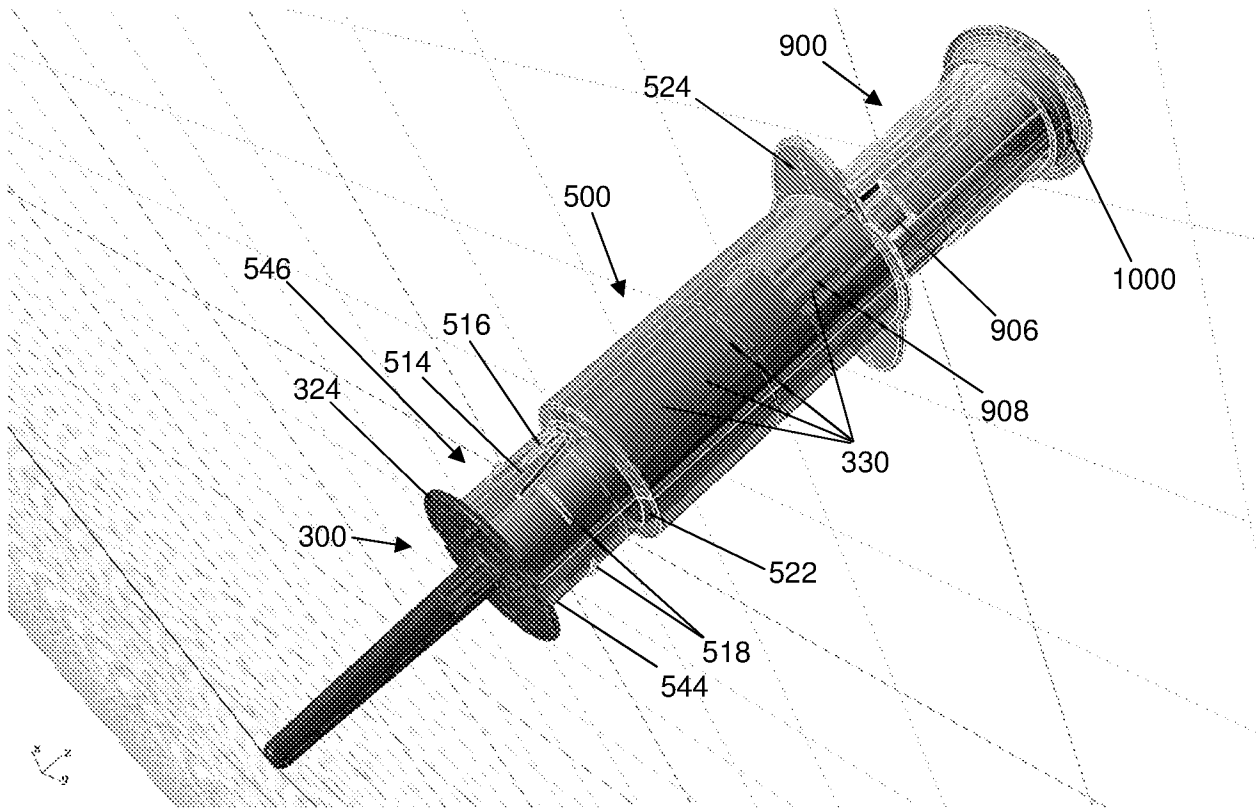

FIG. 7

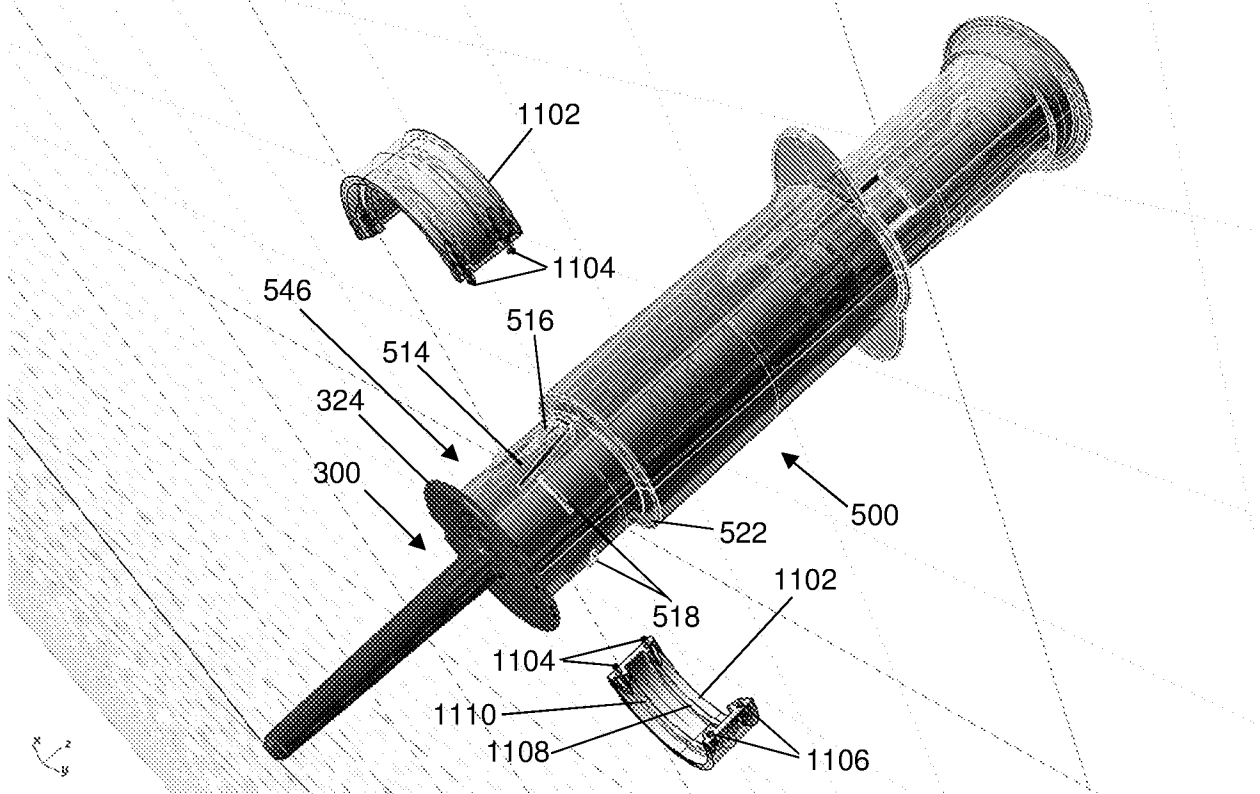

FIG. 8

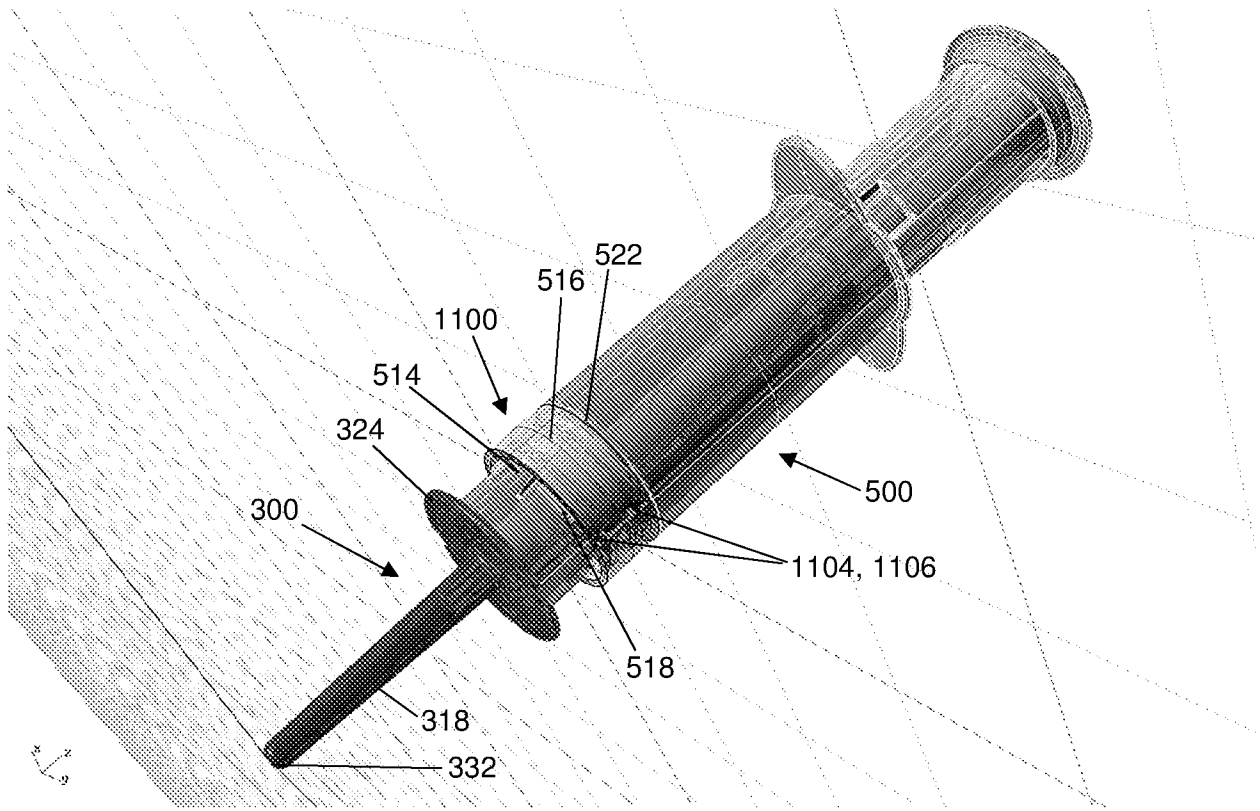

FIG. 9

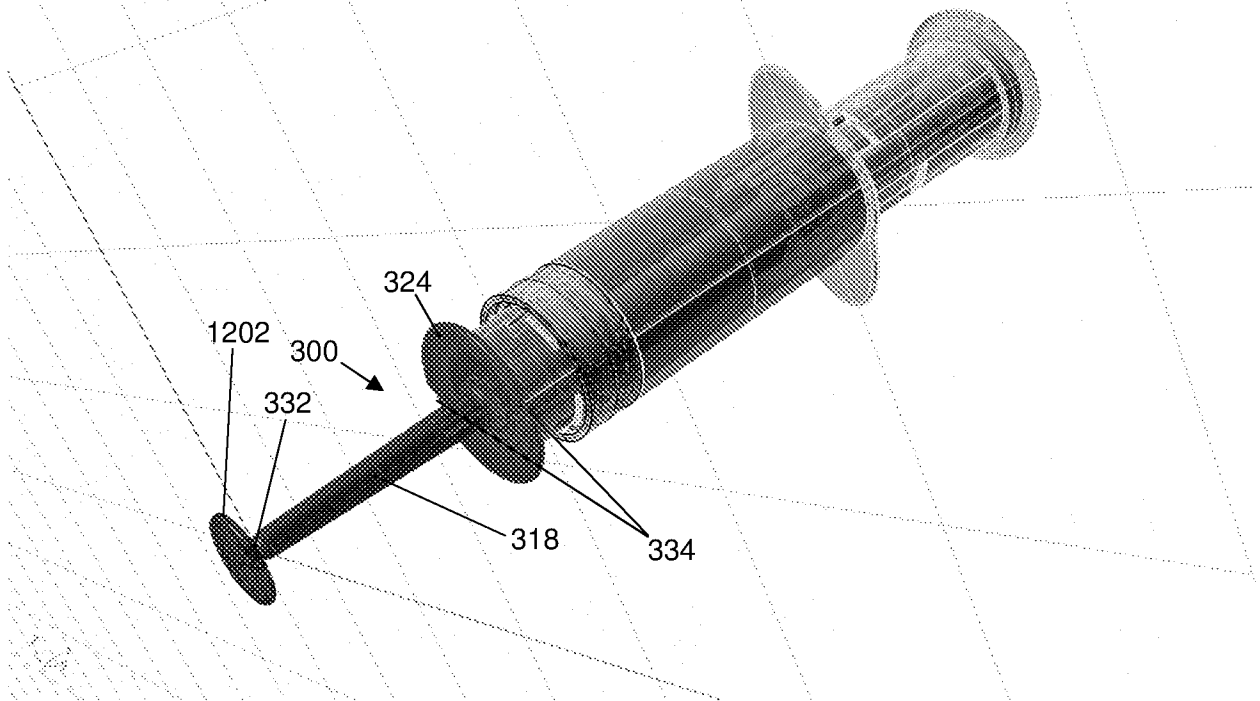

FIG. 10

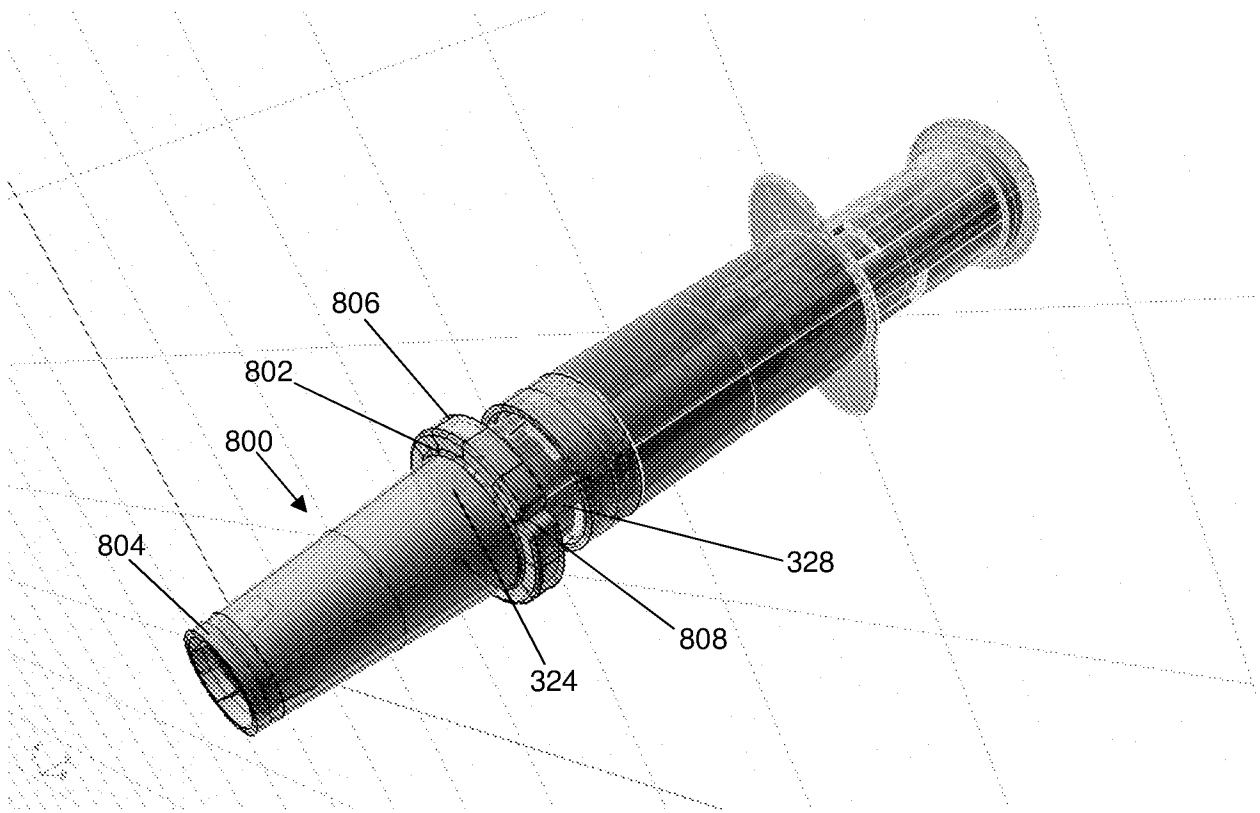

FIG. 11

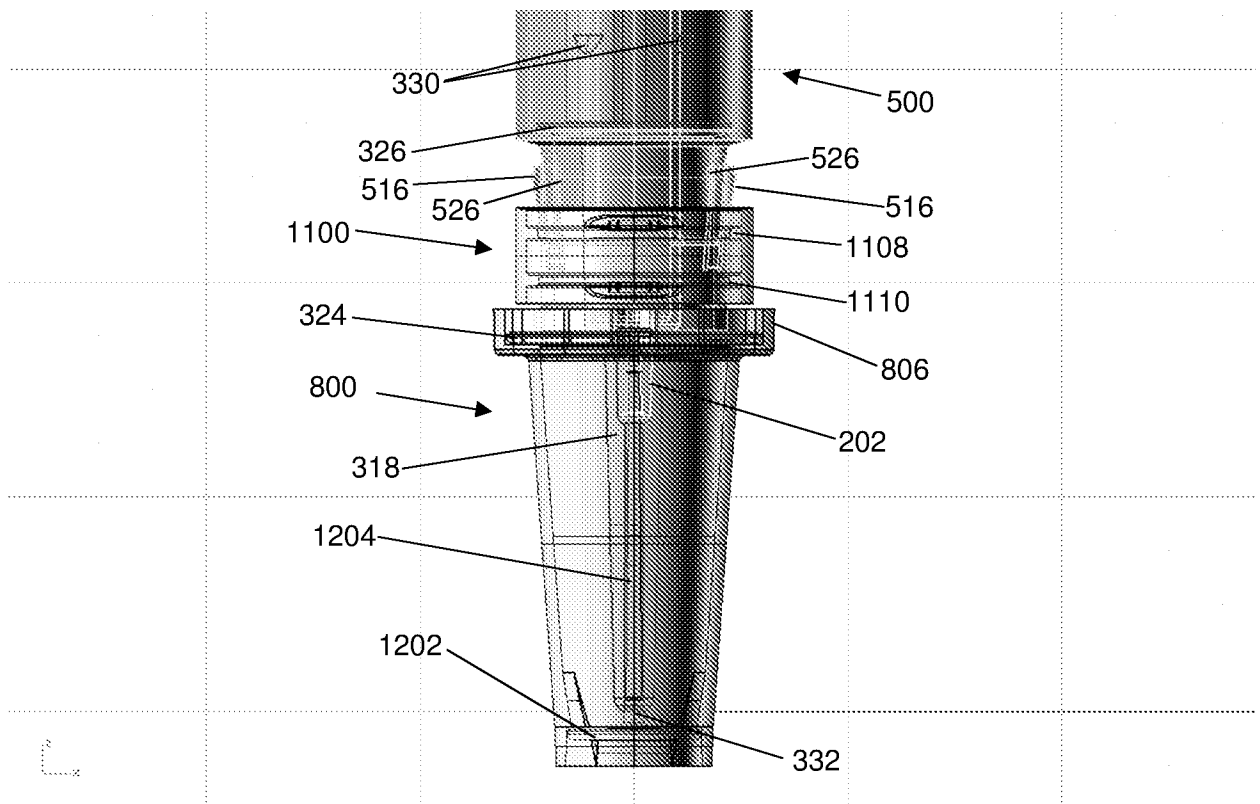

FIG. 12

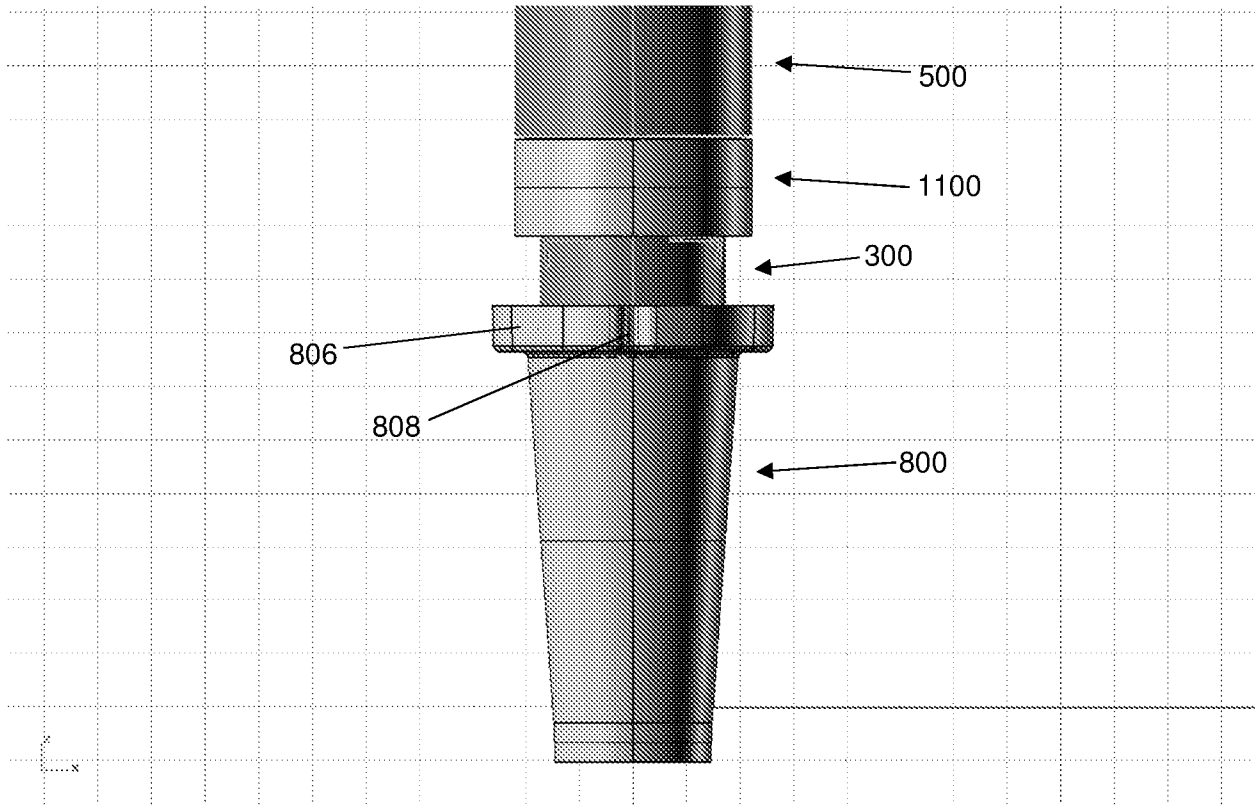

FIG. 13

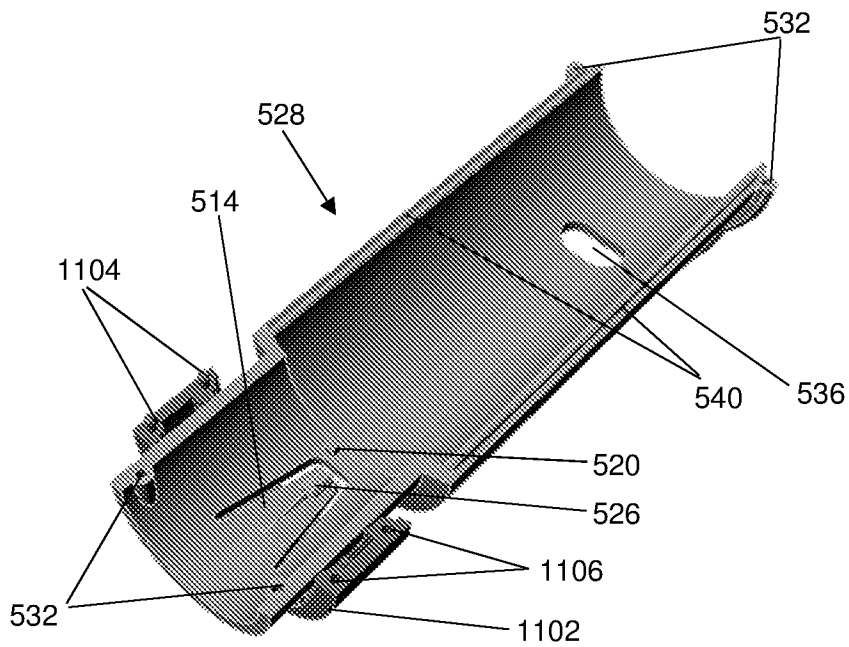

FIG. 14

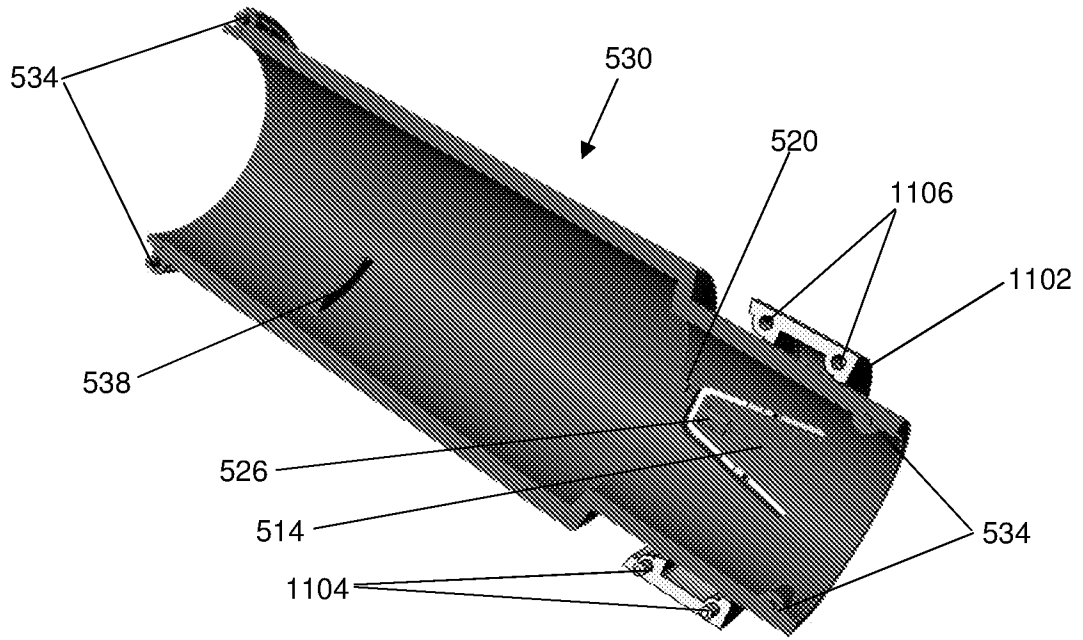

FIG. 15

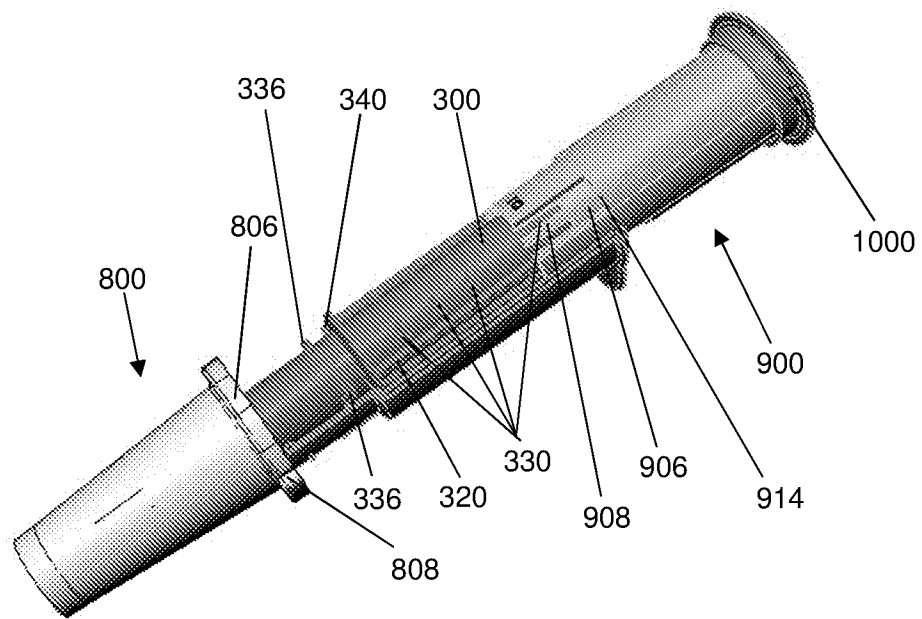

FIG. 16

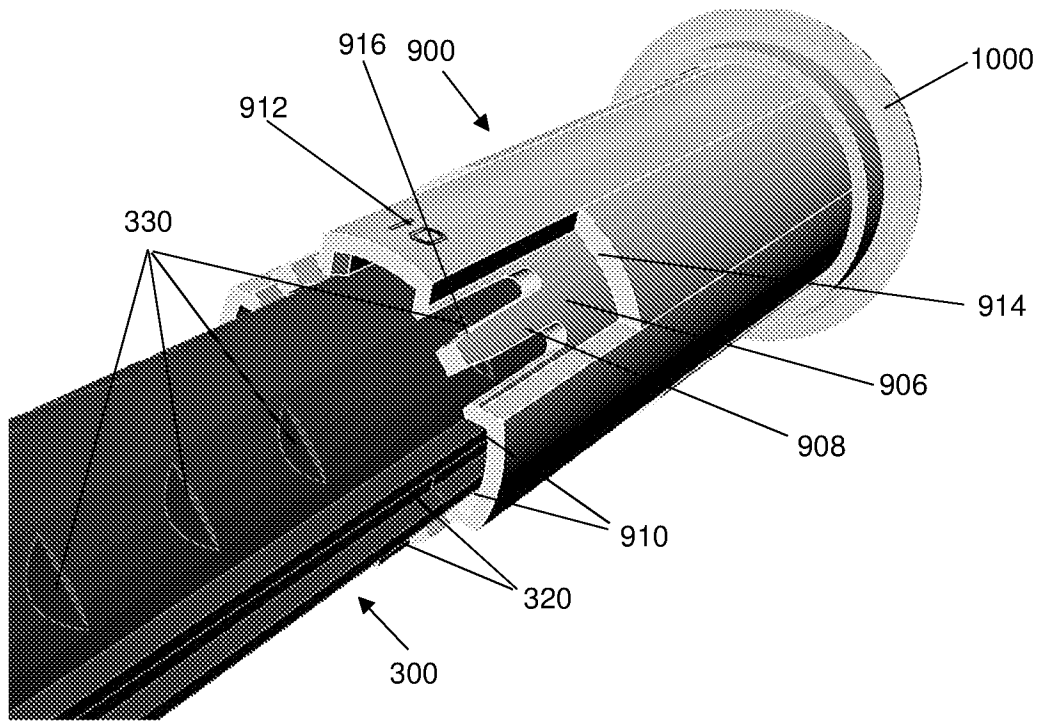

FIG. 17

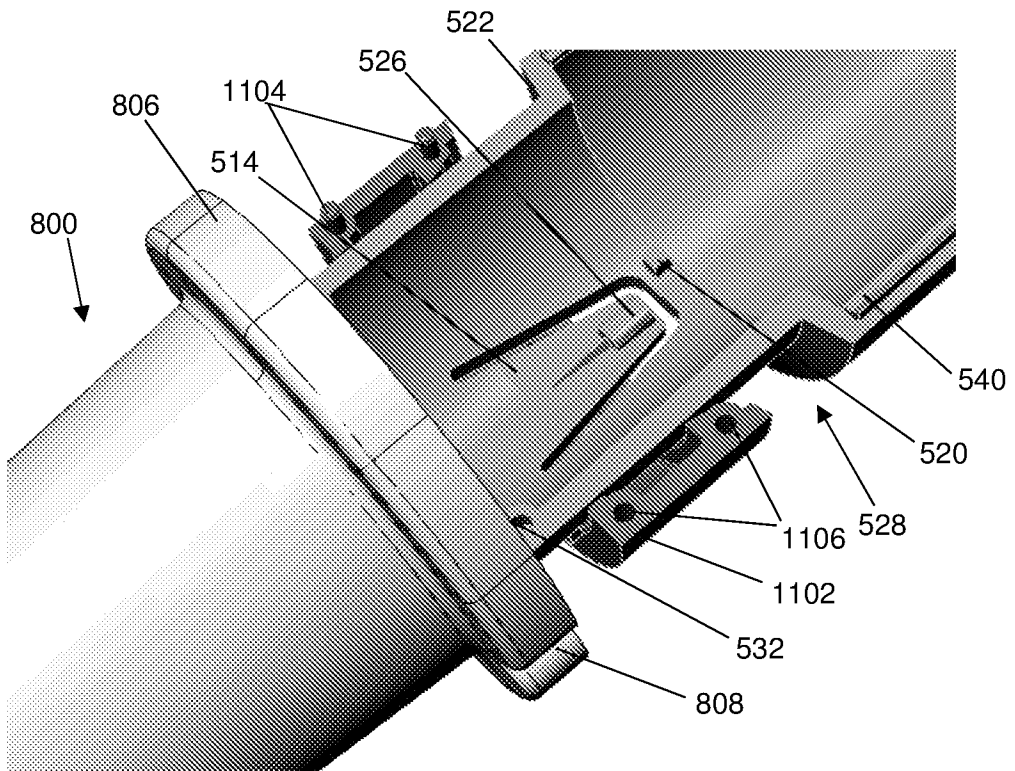
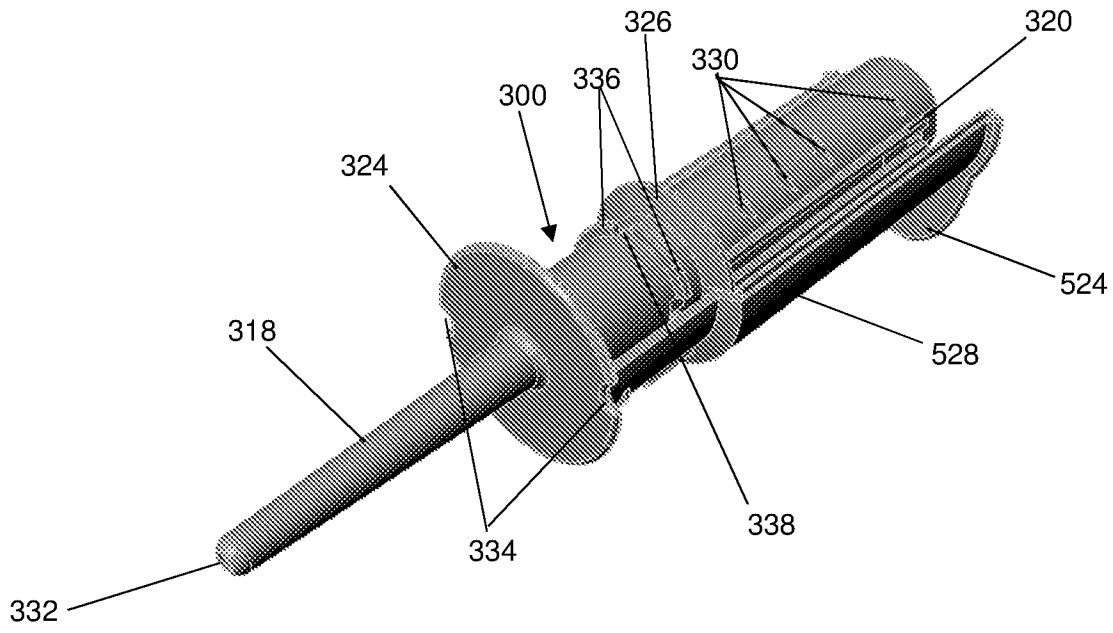

FIG. 18



**FIG. 19**

INTERNATIONAL SEARCH REPORT

International application No.

PCT/US2020/013420

A. CLASSIFICATION OF SUBJECT MATTER  
 IPC(8) - A61M 5/315; A61M 5/178; A61M 5/31 (2020.01)  
 CPC - A61M 5/31548; A61M 5/178; A61M 5/31528; A61M 5/31533; A61M 5/31535; A61M 5/3155; A61M 5/31565; A61M 2005/3125 (2020.02)

According to International Patent Classification (IPC) or to both national classification and IPC

B. FIELDS SEARCHED

Minimum documentation searched (classification system followed by classification symbols)  
 See Search History document

Documentation searched other than minimum documentation to the extent that such documents are included in the fields searched  
 USPC - 604/207; 604/208; 604/211; 604/218 (keyword delimited)

Electronic data base consulted during the international search (name of data base and, where practicable, search terms used)  
 See Search History document

C. DOCUMENTS CONSIDERED TO BE RELEVANT

Category*	Citation of document, with indication, where appropriate, of the relevant passages	Relevant to claim No.
A	WO 2018/085759 A1 (BELOTECA INC) 11 May 2018 (11.05.2018) entire document	1-23
A	US 2010/0324493 A1 (PLUMPTRE) 23 December 2010 (23.12.2010) entire document	1-23
A	US 2004/0162528 A1 (HORVATH et al) 19 August 2004 (19.08.2004) entire document	1-23
A	US 2010/0152672 A1 (RAAB) 17 June 2010 (17.06.2010) entire document	1-23
A	US 9,302,052 B1 (RAFAAT) 05 April 2016 (05.04.2016) entire document	1-23

Further documents are listed in the continuation of Box C.  See patent family annex.

\* Special categories of cited documents:  
 "A" document defining the general state of the art which is not considered to be of particular relevance  
 "E" earlier application or patent but published on or after the international filing date  
 "L" document which may throw doubts on priority claim(s) or which is cited to establish the publication date of another citation or other special reason (as specified)  
 "O" document referring to an oral disclosure, use, exhibition or other means  
 "P" document published prior to the international filing date but later than the priority date claimed  
 "T" later document published after the international filing date or priority date and not in conflict with the application but cited to understand the principle or theory underlying the invention  
 "X" document of particular relevance; the claimed invention cannot be considered novel or cannot be considered to involve an inventive step when the document is taken alone  
 "Y" document of particular relevance; the claimed invention cannot be considered to involve an inventive step when the document is combined with one or more other such documents, such combination being obvious to a person skilled in the art  
 "&" document member of the same patent family

Date of the actual completion of the international search  
 24 February 2020

Date of mailing of the international search report

10 MAR 2020

Name and mailing address of the ISA/US  
 Mail Stop PCT, Attn: ISA/US, Commissioner for Patents  
 P.O. Box 1450, Alexandria, VA 22313-1450  
 Facsimile No. 571-273-8300

Authorized officer  
 Blaine R. Copenheaver

PCT Helpdesk: 571-272-4300  
 PCT OSP: 571-272-7774