

L. W. TRACY.

HAND POWER ROCK DRILL.

No. 246,352.

Patented Aug. 30, 1881.

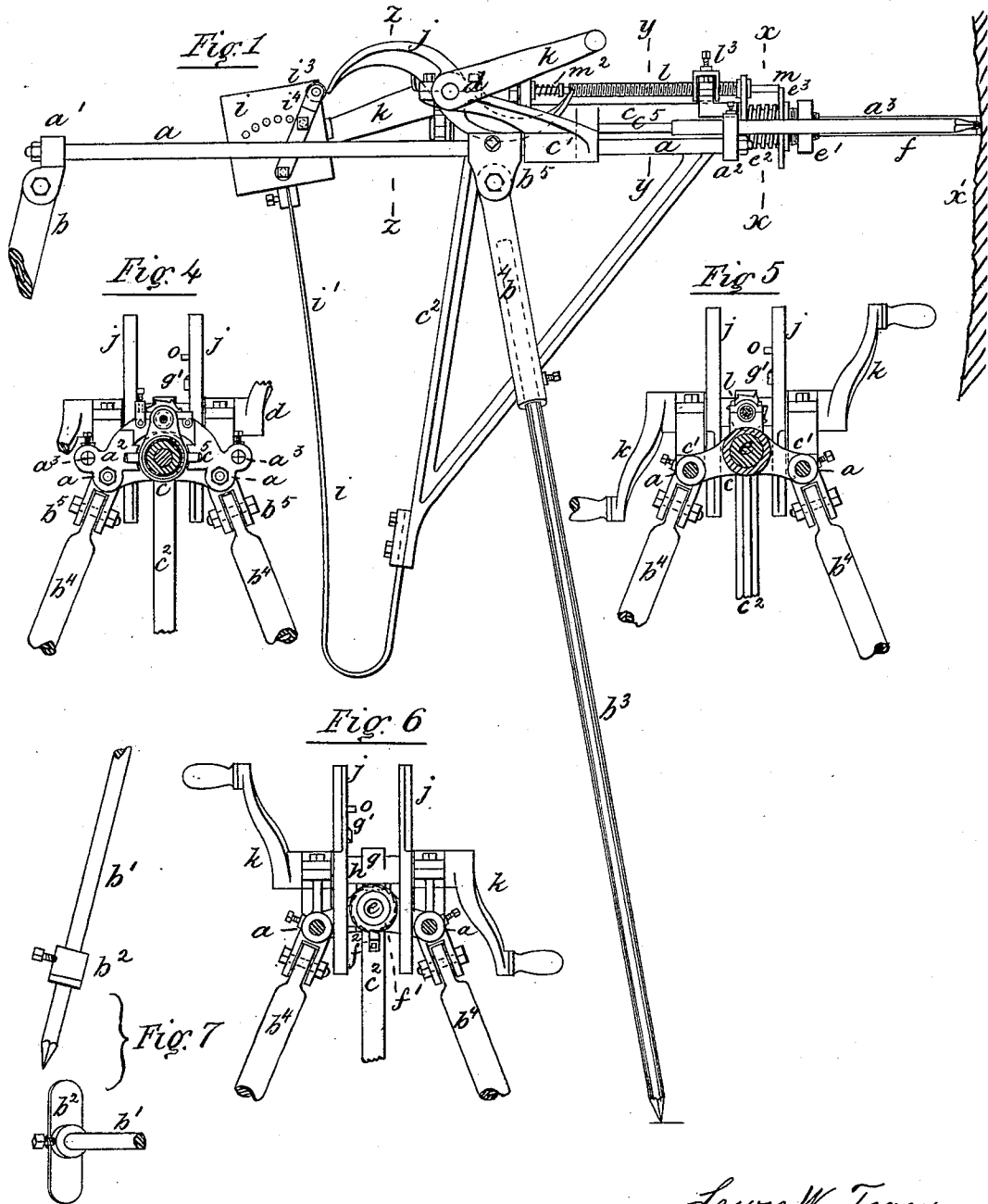

Witnesses.

A. D. Williams
W. M. S. Tarrett

Lewis W. Tracy
Inventor.
per Alfred Hedlock
Att'y.

L. W. TRACY.
HAND POWER ROCK DRILL.

No. 246,352.

Patented Aug. 30, 1881.

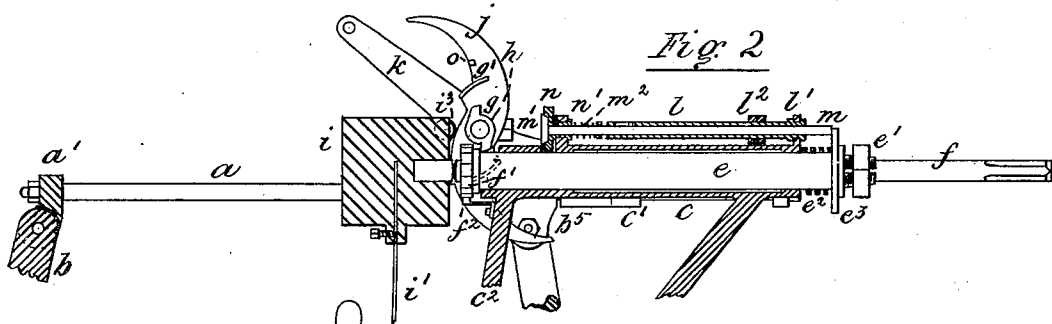

Fig. 2

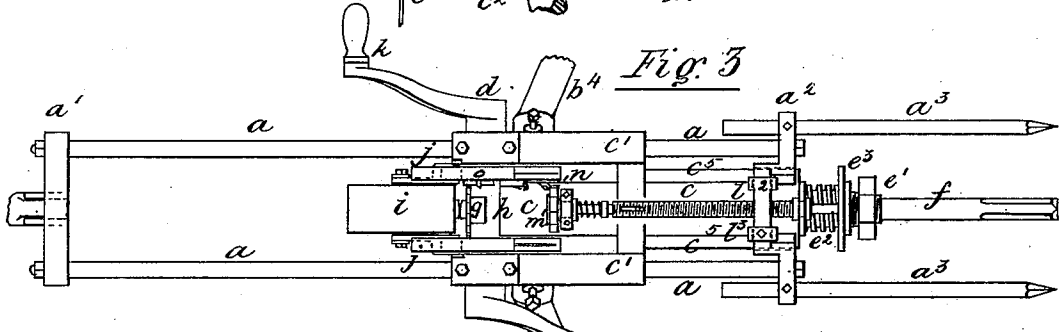

Fig. 3

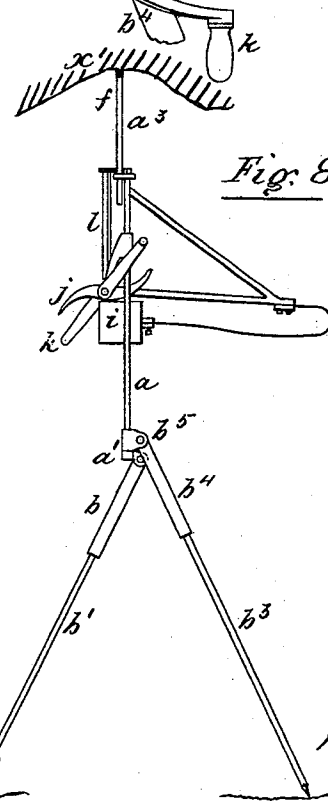

Fig. 8

Witnesses
 H. D. Williams
 W. M. Stanett

Lewis W. Tracy
 Inventor.
 per Alfred Hedlock
 Atty.

UNITED STATES PATENT OFFICE.

LEWIS W. TRACY, OF PHILADELPHIA, PENNSYLVANIA.

HAND-POWER ROCK-DRILL.

SPECIFICATION forming part of Letters Patent No. 246,352, dated August 30, 1881.

Application filed April 4, 1881. (No model.)

To all whom it may concern:

Be it known that I, LEWIS W. TRACY, of Philadelphia, county of Philadelphia, State of Pennsylvania, have invented certain new and useful Improvements in Hand-Power Rock-Drills, of which the following is a specification.

This invention has for its object the production of a portable rock-drill adapted to be operated by hand to drill holes in any direction.

10 It consists of a light rectangular frame provided with adjustable legs, and in which the body of the apparatus is fitted to slide. The drill is held in one end of a plunger passing through the body, and a hammer attached to a spring secured to a bracket forming part of the body is located at the other end of the plunger, and imparts the blow to the drill by the resilience of its spring, the hammer being moved back against the action of this spring
20 by means of two cams secured to a shaft fitted in transverse bearings in the body. Said shaft is provided with a crank-handle at both sides of the machine. Pointed guide-rods project from the front of the machine and hold the
25 drill steady by being pressed into the rock near the hole. After each blow of the hammer the drill is drawn back a short distance by means of a tappet on the center of the cam-shaft working against the side of a ratchet-wheel secured to the end of the plunger next
30 to the hammer, and while the drill is so moved back a helical rib on the side of one of the cams catches into one of the teeth of the ratchet-wheel, and so partly rotates the drill. After
35 the tappet releases the ratchet-wheel the drill is moved forward so as to bear on the bottom of the hole by a spring surrounding the plunger.

40 I also provide the apparatus with an automatic feed device constructed to feed the drill forward only so fast as it accomplishes its work. A hollow screw is located above the body and parallel to the plunger. It is fitted to rotate in a bearing on the drill end of the
45 body, and through it is passed a rod fitted to slide freely longitudinally, but connected to rotate with the hollow screw. This rod also passes freely through a ratchet-wheel held in a bearing on the body near the cam-shaft, and

50 on the end of the rod is secured a taper disk adapted to fit into a corresponding recess in the side of the ratchet-wheel, said disk being held in the recess by means of a spring with sufficient friction to cause the rod and the hollow screw to turn with the ratchet-wheel when
55 it is actuated. The other end of this rod projects beyond the hollow screw, and is acted on by a flange on the plunger when the drill is being drawn back, so as to move the taper disk out of the recess in the ratchet-wheel. A
60 half-nut fitted to the hollow screw is pivoted to the front end of the rectangular frame, so that the body and working parts of the machine may be adjusted in the frame as desired, when the half-nut is moved away from the
65 screw, and when in contact therewith the body is moved forward and feeds the drill to its work by means of a tooth on the side of one of the cams operating the ratchet connected by friction to the rod passing through the
70 screw. The teeth of this ratchet-wheel are of such a pitch that the ratchet-wheel being moved one tooth after each blow of the hammer will cause the hollow screw to feed the drill forward the maximum distance—that is, the greatest
75 depth the drill will cut each stroke. If the drill at any time should not cut the maximum depth, then the flange on the plunger will prevent the taper disk entering fully into the recess in the ratchet-wheel, and consequently the disk-rod and hollow screw will not
80 be turned with the ratchet-wheel, so the drill will not be again fed forward until it has cut forward in the rock sufficiently to allow the disk to be properly gripped by the ratchet-
85 wheel.

In the accompanying drawings, to which I will now refer to more fully describe my invention, Figure 1, Sheet 1, is a side elevation of the hand-power rock-drill in position to drill a
90 horizontal hole, showing the rear leg broken away. Fig. 2, Sheet 2, is a longitudinal central section. Fig. 3, Sheet 2, is a plan view. Fig. 4, Sheet 1, is a transverse section cut through the line *xx*, Fig. 1, looking toward the left. Fig. 5, Sheet 1, is another transverse section
95 cut through the line *yy*, also looking toward the left. Fig. 6, Sheet 1, is a transverse sec-

tion cut through the line $z z$, Fig. 1, looking toward the right. Fig. 7, Sheet 1, is a detached and plan view of the rear leg. Fig. 8, Sheet 2, is a diagram view of the drill in position to drill overhead holes.

In Fig. 1 the crank-handles are turned so that the cams are just about to allow the hammer to rebound against the plunger, and in all the other views the cams are just about to raise the hammer.

The rectangular frame is composed of two side rods, $a a$, and end pieces, a^1 and a^2 , in which the rods are secured by means of nuts on their ends. Between ears on the end piece, a^1 , is held the upper part of the rear leg, b , by means of a bolt. The lower part, b^1 , fits telescopically in the upper part, and it is provided with an adjustable foot-piece, b^2 , upon which the operator places his feet to assist in holding the machine steady while at work, as shown detached from the upper part of the leg b , and in plan at Fig. 7. Two other legs are provided, consisting of the pointed rods $b^3 b^3$ and tubular pieces $b^4 b^5$ pivoted in the sockets $b^5 b^5$. These sockets $b^5 b^5$ fit on the rods $a a$, and are adapted to be moved along the same for the adjustment of the machine in a horizontal position, as shown at Fig. 1, or in any angular position, and when it is desired to drill upwardly, as represented in the diagram view, Fig. 8, the sockets $b^5 b^5$ may be slid along the rods $a a$, to be in close proximity to the end piece, a^1 , the sockets being held firmly upon the rods by means of set-screws.

The body of the machine consists of a cylindrical shell, c , having sockets $c^1 c^1$ on its sides, which embrace the rods $a a$ of the frame. These sockets extend rearwardly over the rods to provide bearings for the cam-shaft d . On the sides of the cylindrical shell c are longitudinal flanges c^5 , which fit in grooves formed in the front end piece, a^2 , thereby holding the body, with working parts, steady as it slides along the rods $a a$ in feeding the drill to its work, as shown at Fig. 4.

Two guide-rods, $a^3 a^3$, are held in the front end piece, a^2 , by means of set-screws. Their pointed ends are shown as set about in line with the point of the drill f , and in starting the operation these points are pressed into or against the rock x^1 , as represented in Figs. 1 and 8.

The plunger e is fitted to slide longitudinally and rotate in the cylindrical shell c of the body, and in its front end is held the drill f by means of the nut e^1 , adapted to contract the end of the plunger on the drill when the nut is screwed up. The drill may be held in the plunger by means of the ordinary clamp.

The spring e^2 , located between the end of the cylindrical shell c and the flange c^5 on the plunger e , holds the plunger and drill in the position shown in the drawings, so that the end of the drill bears against the bottom of the hole. On the other end of the plunger e is secured the ratchet-wheel f^1 , against the side

of which one of the tappets g on the connecting-hub h of the cams acts to draw the drill a short distance from the bottom of the hole after each stroke, and while the plunger and drill are so held back one of the helical ribs g^1 on the side of one of the cams j is in position to work the adjacent tooth of the ratchet-wheel f^1 , and so cause the plunger and drill to partly rotate. These movements take place during the time the hammer is being moved back to impart the blow to the end of the plunger. The hammer i is secured to the end of the bent spring i^1 , held in a socket on the lower end of the bracket e^2 , projecting downwardly from the cylindrical shell c . The spring f^2 holds the ratchet-wheel from turning backward.

The hammer i is moved back by the two double cams $j j$ secured to the shaft d , which are rotated by means of the crank-handles k on the ends of the shaft d , and which act on the rollers $i^2 i^2$, pivoted on the plates i^4 , secured at their lower ends and near the roller to the sides of the hammer i by screw-bolts. A series of tapped holes is provided in each side of the hammer, arranged in a circle, whose center is the lower holding screw-bolt, as shown at Fig. 1, thus enabling the force of the blow to be regulated by setting the upper screw-bolt in any of the tapped holes and so governing the distance the hammer is moved back by the cams $j j$. The hammer is not released from the ends of the cams $j j$ until after the plunger e has been partly rotated by the helical rib g^1 and moved forward to press the end of the drill against the bottom of the hole by the spring e^2 , and the feeding device has been actuated. This feeding device consists of the hollow screw l , fitted to rotate in the bearing l^1 on the top of the cylindrical shell c , but without longitudinal freedom in said bearing. The rod m passes through the screw l and through the ratchet-wheel n , which is fitted to rotate only in the bearing n^1 in line with the bearing l^1 , and also forming a part of or secured to the cylindrical shell c .

The rod m is provided with a key and the screw l with a longitudinal slot, so that the screw is caused to rotate with the rod, and on the end of the rod is secured the taper disk m^1 , which fits into a correspondingly-shaped recess in the side of the ratchet-wheel n . It is held therein by the spring m^2 with sufficient friction to cause the rod to turn with the ratchet-wheel; or, if desired, the edge of the disk m^1 and sides of the recess may be serrated. The screw l passes through a plain semicircular hole formed in the front end piece, a^2 , of the frame, to which is pivoted the half-nut l^2 . This half-nut is held down on the screw l by the yoke l^3 and set-screw passing through the yoke, so that the screw is rotated by the tooth o on one of the cams j working in the teeth of the ratchet-wheel n , just after the tappet g has released the ratchet-wheel f^1 and allowed the drill to strike the bottom of the hole, as be-

fore described, and before the hammer is allowed to strike against the end of the plunger. The flange e^3 on the front end of the plunger e is in contact with the front end of the rod m when the plunger is moved back, and so after each stroke the taper disk m' is pushed clear of the ratchet-wheel n , and should the drill not have cut in the hole sufficiently to allow the disk to fully enter the recess in the ratchet-wheel n , then when the ratchet is turned no motion is imparted to the screw l , and the body and working parts of the machine do not move forward in the frame; but after one or more strokes the disk will be gripped by the ratchet-wheel n and the body, &c., moved forward. These forward-feeding motions for each stroke are such as to be a little in excess of the greatest depth the drill will cut at each stroke in the softest rock it is designed to bore, so that the end of the drill is always against the bottom of the hole when the blow of the hammer is imparted to the end of the plunger. Otherwise the force of the blow would be received by the body of the machine.

When the depth of the hole to be drilled is greater than the length of the feed-screw l a somewhat longer drill is used than that shown, and in such case when the screw has fed the machine forward as far as it is capable of doing the half-nut l^2 is thrown back, the set-screws holding the guide-bars a^3 , and the sockets b^5 are slackened and the frame of the machine is pushed forward until the half-nut l^2 is at the front end of the feed-screw. The half-nut is then closed down on the feed-screw, and the set-screws are again tightened and the drilling operation continued, the drill feeding automatically forward until the other end of the feed-screw again reaches the half-nut.

By sliding the legs to the rear end of the frame the machine may be set to drill upwardly, as represented at Fig. 8, and it will be seen that the legs may be readily set to enable the drill to operate in a downward direction.

The helical ribs $g' g'$, instead of being on the side of one of the cams j , may be formed on the side of a separate plate secured to the shaft d . The teeth o for actuating the ratchet-wheel n may also be on the side of a plate instead of on the cam j .

The feed mechanism may be modified by securing the disk on the rod m , near the rear end of the hollow screw l , and fastening a recessed plate on the end of the screw, and cutting a splineway through the ratchet-wheel n , with a spline fitting therein on the rod m , so that the rod will always turn with the ratchet-wheel n , and only actuate the feed-screw when the disk is in the recessed plate.

Belt or chain wheels may be substituted for the hand-cranks k and the drill operated by steam or other power.

Instead of making the cams $j j$ two-throw, they may, if a very hard blow is desired, be made single-throw cams, and the spring i' made stronger. The number of tappets g , heli-

cal ribs g' , and teeth o will correspond to the throw of cams j .

It is obvious that the feeding device is adapted to be used with other kinds of rock drilling machines, and that parts of the machine described may be used independently, so I do not wish to confine myself to the particular construction and arrangement of the various devices; but

What I claim, and desire to secure by Letters Patent, is—

1. In a rock-drilling machine, a spring acting hammer provided with adjustable rollers, in combination with cams secured to a rotating shaft at right angles to the motion of the hammer, whereby the force of the blow is regulated by the distance the hammer is moved back by the cams, substantially as set forth.

2. In a rock-drilling machine, in combination, a drill-holding plunger, ratchet-wheel on the rear end of same, a tappet on a transversely-rotating shaft, adapted to withdraw the drill from the bottom of the hole by acting against the side of the ratchet-wheel, and a helical rib on the side of a cam or plate secured to the shaft and arranged to work in the teeth of the ratchet-wheel to partly rotate the plunger when the plunger is held back by the tappet, substantially as and for the purpose hereinbefore set forth.

3. In a frame for rock-drilling machines, in combination, two rods connected at their ends by end pieces, the rear leg pivoted to one of the end pieces, two adjustable guide-rods secured in the other end piece by means of set-screws, and two legs pivoted in sockets adapted to slide along the rods and be clamped thereto, substantially as and for the purpose hereinbefore set forth.

4. In a feeding device for rock-drilling machines, in combination, a hollow screw working in a bearing on the body and through a nut on the frame, a rod extending through the screw, but adapted to turn therewith, a taper disk secured to the end of the rod, a ratchet-wheel fitted in a bearing on the body and recessed out to receive the disk, a spring for pressing the disk in the recess, a tooth on the side of a cam or plate secured to the driving-shaft, and adapted to actuate the ratchet-wheel, and a flange on the front end of the drill-carrying plunger to hold the disk out of the recess, substantially as and for the purpose hereinbefore set forth.

5. In a rock-drilling machine, in combination, the spring-acting hammer, the cams on a transverse shaft, the drill-holding plunger adapted to receive the blows from a hammer, and provided at its front end with a flange for holding the connecting-gear of the feeding device out of gear until the force of the blows of the hammer has driven the drill forward such a distance as to require a feeding forward of the working parts of the machine, substantially as set forth.

6. The combination, with the rear leg of a

hand-power rock-drill, of an adjustable foot-piece, substantially as and for the purpose hereinbefore set forth.

7. In a hand-power rock-drill, the frame composed of two rods secured together by two end pieces, in combination with the body, provided with two sockets to fit over the rods and two flanges adapted to fit into grooves of one of the end pieces of the frame, substantially as
10 and for the purpose hereinbefore set forth.

8. In a rock-drilling machine, the spring-acting hammer *i*, the cams *j*, secured to the transverse shaft *d*, the drill-holding plunger *e*, the

ratchet-wheel *f'*, the tappets *g g*, the helical ribs *g' g'*, the flange *e³*, spring *e²*, screw *l*, half- 15 nut *l²*, rod *m*, taper disk *m'*, spring *m²*, ratchet-wheel *n*, and teeth *o o*, constructed and combined substantially as and for the purpose hereinbefore set forth.

In testimony whereof I have hereunto set 20 my hand this 30th day of March, A. D. 1881.

LEWIS W. TRACY.

Witnesses:

THOMAS W. SPARKS,
JAMES U. VOGDES.