



(12) **United States Design Patent**  
**Jiang**

(10) **Patent No.:** **US D1,006,567 S**  
(45) **Date of Patent:** **\*\* Dec. 5, 2023**

(54) **LUNCH BOX**

**FOREIGN PATENT DOCUMENTS**

(71) Applicant: **Zhongyong Jiang**, Guangxi (CN)

EM 015028438-0001 \* 8/2023  
EM 015028438-0002 \* 8/2023

(72) Inventor: **Zhongyong Jiang**, Guangxi (CN)

(Continued)

(\*\*) Term: **15 Years**

**OTHER PUBLICATIONS**

(21) Appl. No.: **29/903,280**

Azubien Electric Lunch Box. Aug. 31, 2023. Site visite Sep. 30, 2023. [https://www.amazon.com/dp/B0C78H1XNZ/ref=sbl\_dp\_x\_dining-lunch-boxes\_B0BFYSQWHH\_0] (Year: 2023).\*

(22) Filed: **Sep. 21, 2023**

(Continued)

(51) **LOC (14) Cl.** ..... **07-02**

(52) **U.S. Cl.**

USPC ..... **D7/709; D7/629**

(58) **Field of Classification Search**

USPC ..... D7/629, 630, 601, 602, 538-542, 612, D7/608, 300, 312, 316, 323, 353, 900, D7/387, 368, 388, 397, 402, 403, 412, D7/500, 550.1, 552.1, 552.2, 553.1, D7/553.2, 553.3, 554.4, 555, 701-710; D9/424-433, 445, 500, 501, 503, 504, D9/516, 549, 575, 415-419, 737, 760, D9/761, 759, 756, 479, 478, 420, 421; D19/102, 75, 77; D8/71; D3/201, 203, D3/206, 273, 274, 302

CPC ..... B65D 85/50; B65D 85/505; B65D 85/52; B65D 43/02; B65D 1/26; B65D 43/0206; B65D 43/0214; B65D 6/00; A47J 47/01; A47J 42/14; A47J 42/34; A47J 42/50; A47J 47/02; A47J 47/08; A47J 47/10; A47J 41/00; A21B 1/52; H05B 3/02

See application file for complete search history.

*Primary Examiner* — Wendy L. Arminio

*Assistant Examiner* — Maheen Khurshid

(74) *Attorney, Agent, or Firm* — Kunzler Bean & Adamson, PC; Alandra Adams

(57)

**CLAIM**

The ornamental design for a lunch box, as shown and described.

**DESCRIPTION**

FIG. 1 is a front, right and top perspective view of a lunch box, showing my design.

FIG. 2 is a rear, left and bottom perspective view thereof.

FIG. 3 is a front elevation view thereof.

FIG. 4 is a rear elevation view thereof.

FIG. 5 is a left side elevation view thereof.

FIG. 6 is a right side elevation view thereof.

FIG. 7 is a top plan view thereof.

FIG. 8 is a bottom plan view thereof; and,

FIG. 9 is an enlarged view of detail 9 in FIG. 1.

The broken lines depict portions of the lunch box that form no part of the claimed design. The dot-dash broken lines in FIGS. 1 and 9 depict the boundaries of the enlarged view and form no part of the claimed design.

(56)

**References Cited**

**U.S. PATENT DOCUMENTS**

4,279,342 A \* 7/1981 Van Pelt ..... A45C 11/20 455/344  
D335,067 S \* 4/1993 Hamilton ..... D7/709  
D373,953 S \* 9/1996 Gale ..... D7/629  
D379,138 S \* 5/1997 Carlson ..... D7/629  
D479,955 S 9/2003 Samartgis  
D547,130 S \* 7/2007 de Groote ..... D7/629

(Continued)

**1 Claim, 9 Drawing Sheets**

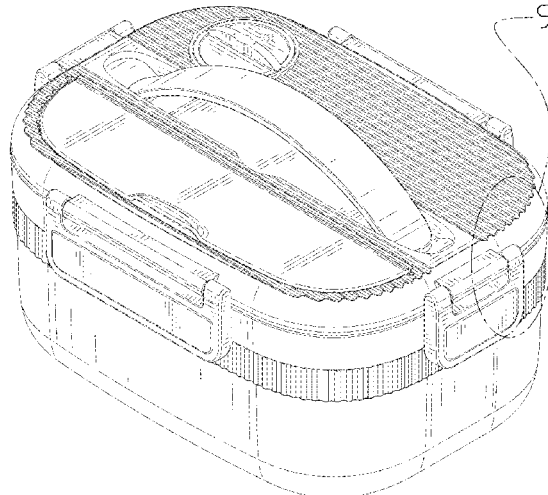

(56)

**References Cited**

U.S. PATENT DOCUMENTS

D788,518 S \* 6/2017 Aggarwal ..... D7/360  
D829,066 S 9/2018 Xu  
D882,344 S \* 4/2020 Lin ..... D7/609  
D909,835 S \* 2/2021 Lin ..... D7/709  
D963,436 S \* 9/2022 Chen ..... D7/703  
D963,437 S \* 9/2022 Lei ..... D7/709

FOREIGN PATENT DOCUMENTS

EM 015028438-0003 \* 8/2023  
EM 015028438-0004 \* 8/2023

OTHER PUBLICATIONS

Electric Lunch Box. Sep. 9, 2021. Site visite Sep. 30, 2023.  
[[https://www.amazon.com/dp/B09FT4JBQ6/ref=sbl\\_dp\\_dining-lunch-boxes\\_B0C64JJ7RJ\\_0?th=1](https://www.amazon.com/dp/B09FT4JBQ6/ref=sbl_dp_dining-lunch-boxes_B0C64JJ7RJ_0?th=1)] (Year: 2021).\*

Thermal Lunch Box. Sep. 15, 2022. Site visite Sep. 30, 2023.  
[[https://www.amazon.com/dp/B0BFFQBN9L/ref=sbl\\_dp\\_dining-lunch-boxes\\_B0B3MM7B1K\\_0?th=1](https://www.amazon.com/dp/B0BFFQBN9L/ref=sbl_dp_dining-lunch-boxes_B0B3MM7B1K_0?th=1)] (Year: 2022).\*

Medicine Cabinets. Apr. 18, 2022. Site visite Sep. 30, 2023.  
[<https://www.amazon.ca/Medicine-Containers-Organizer-Compartments-30X22X22CM/dp/B09Y5JM9HK>] (Year: 2022).\*

\* cited by examiner

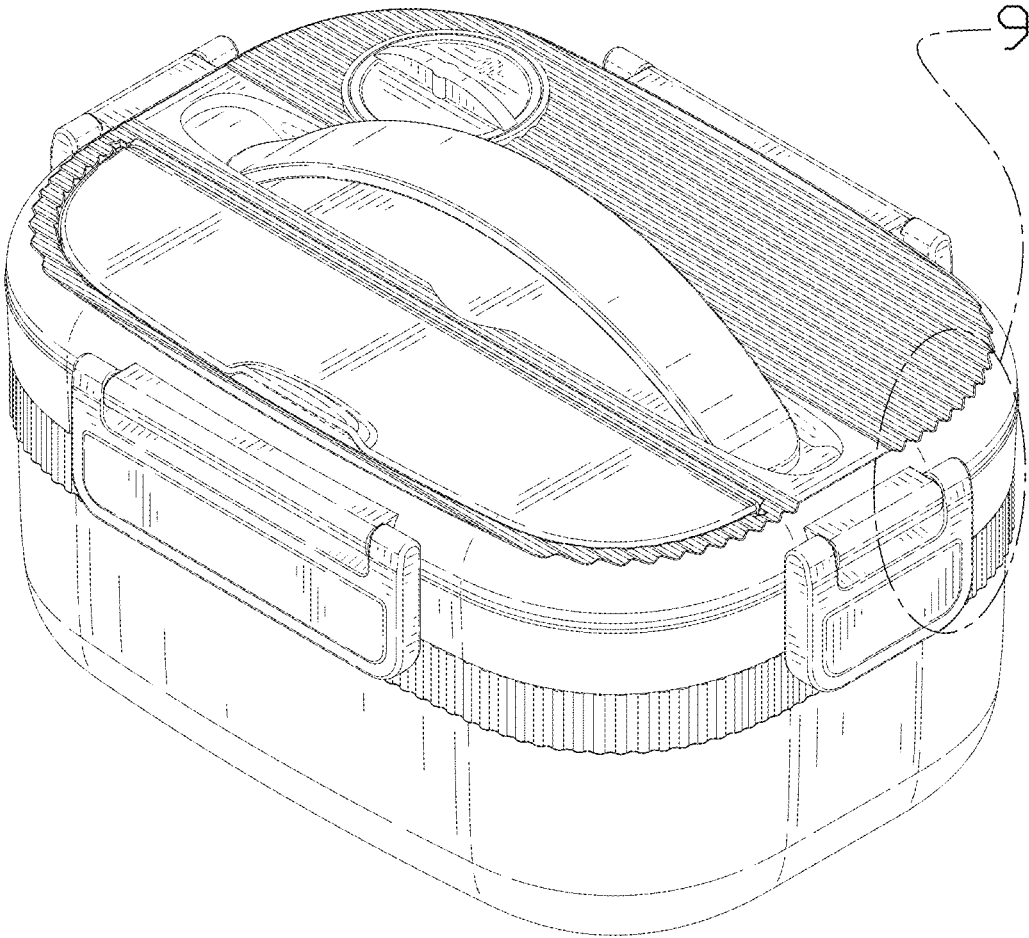

FIG. 1

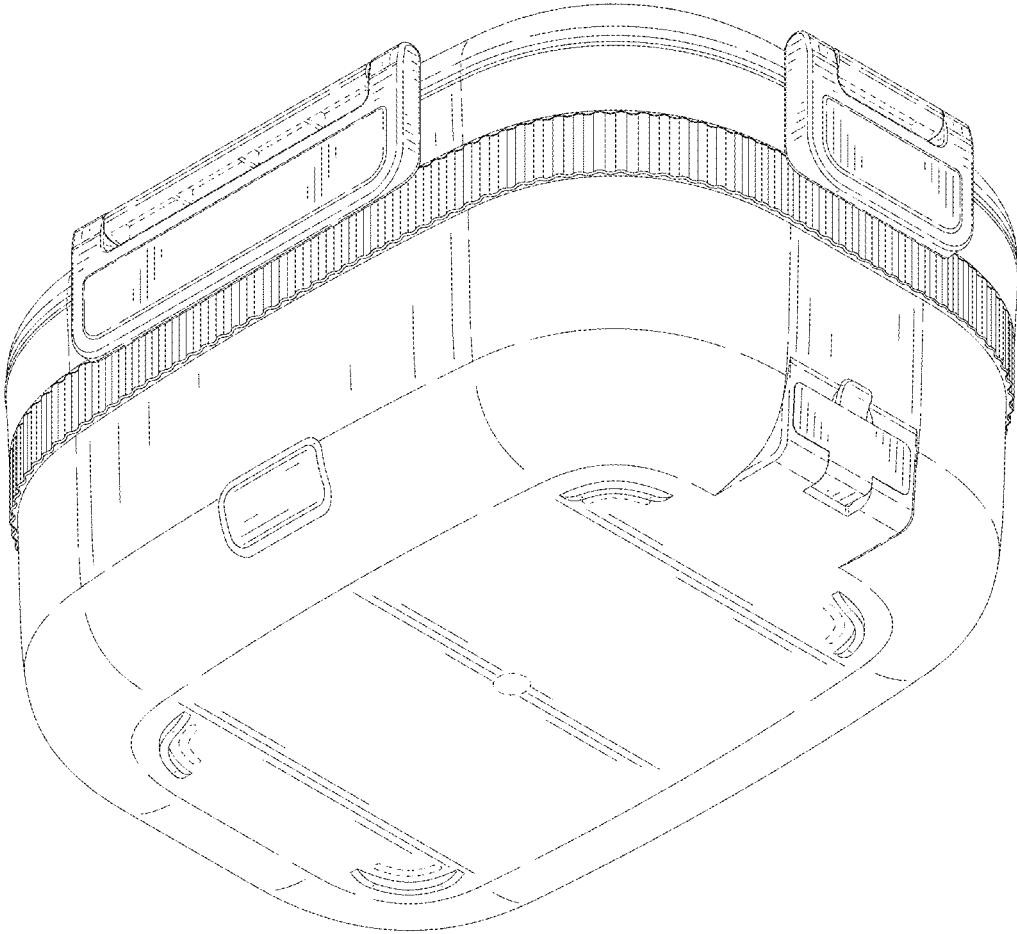

FIG. 2

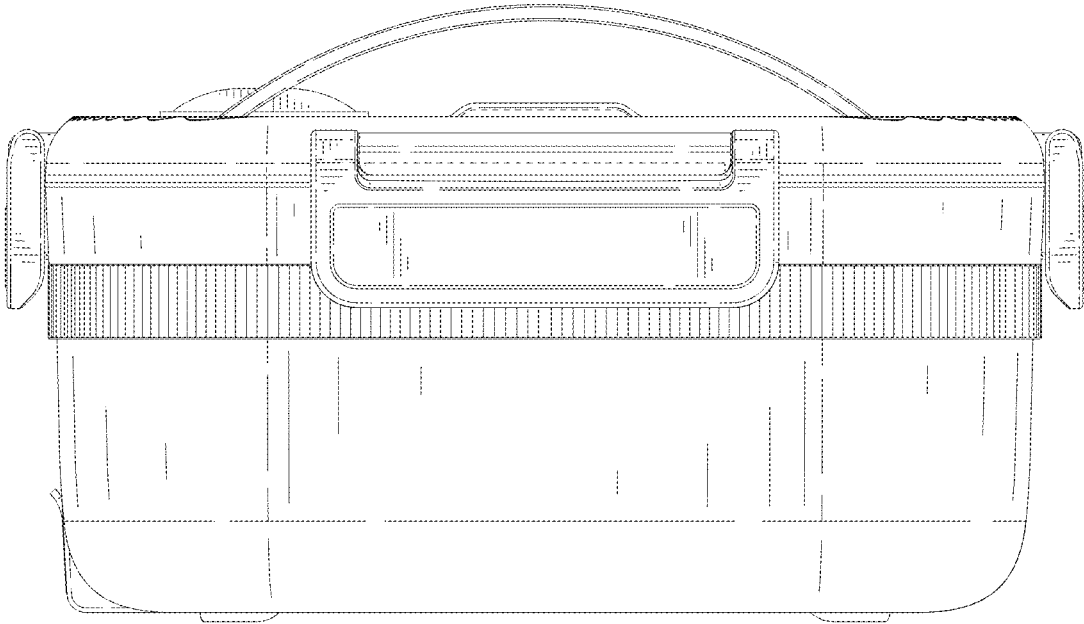

FIG. 3

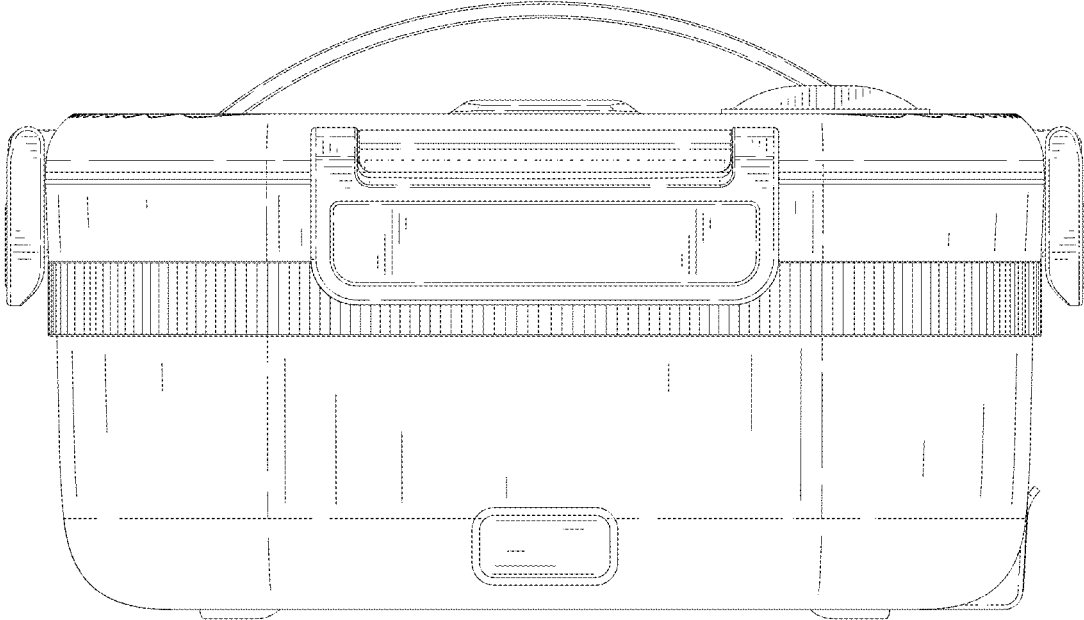

FIG. 4

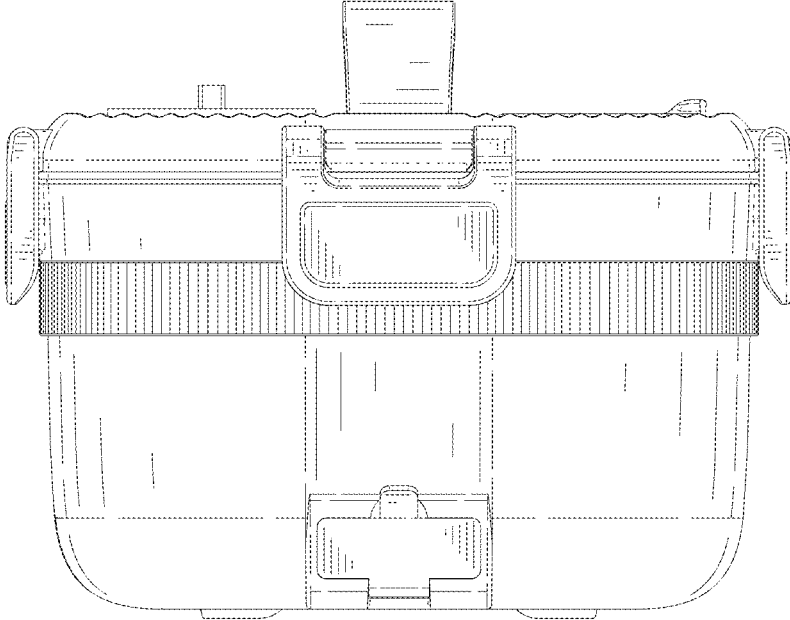

FIG. 5

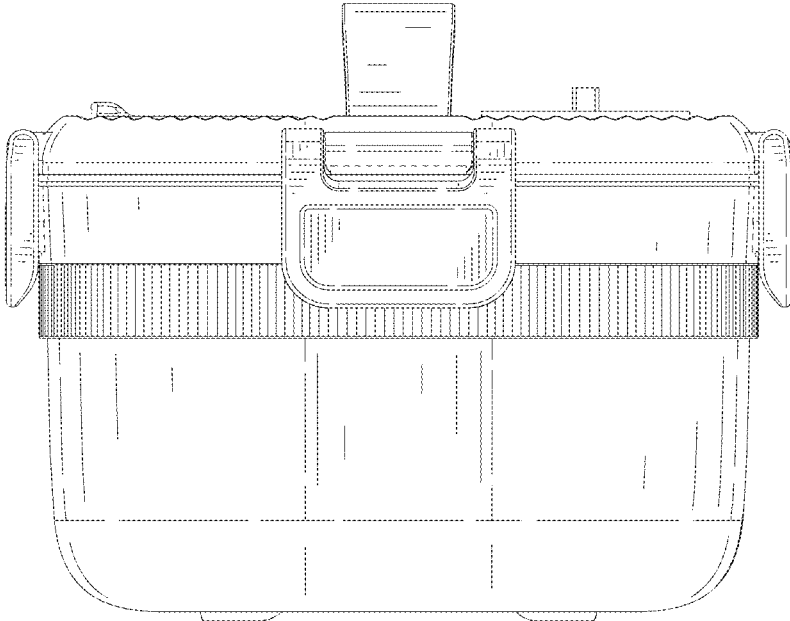

FIG. 6

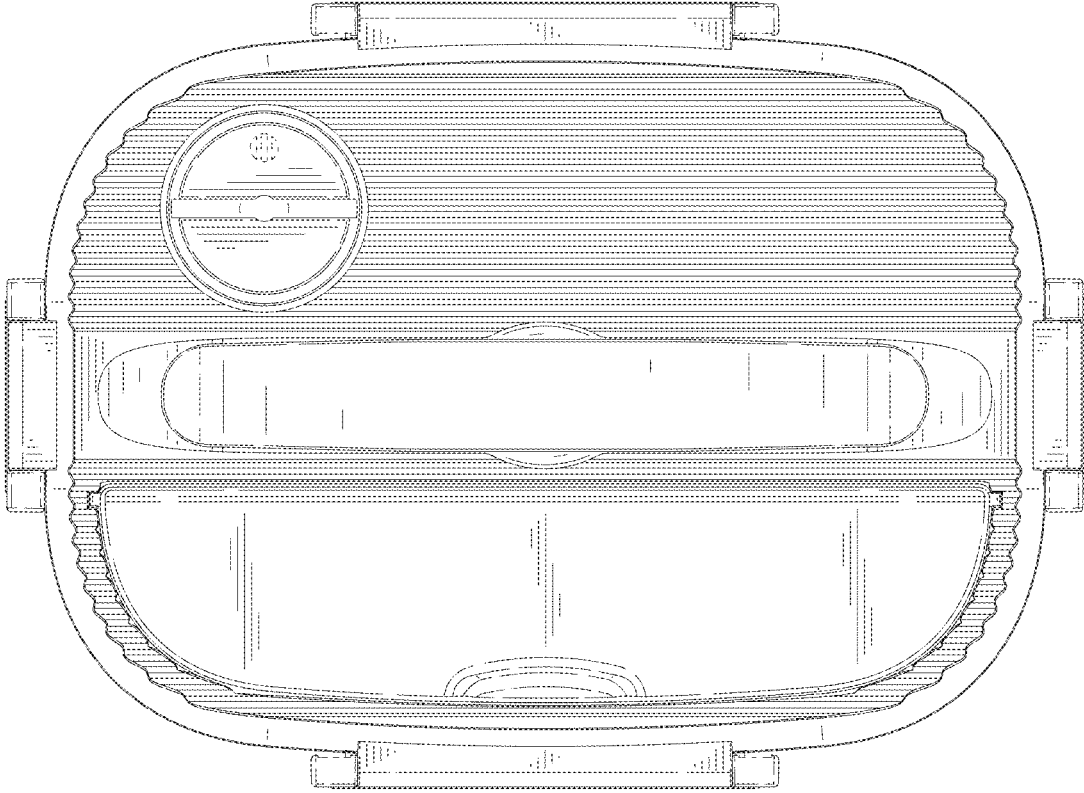

FIG. 7

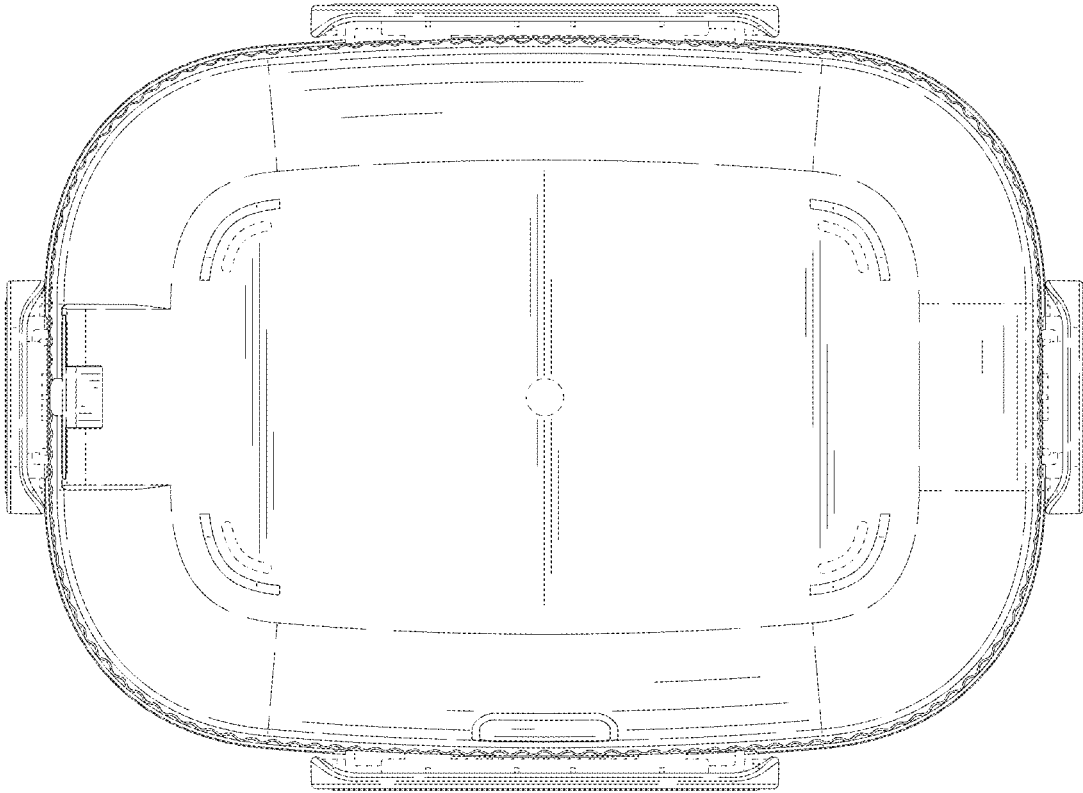

FIG. 8

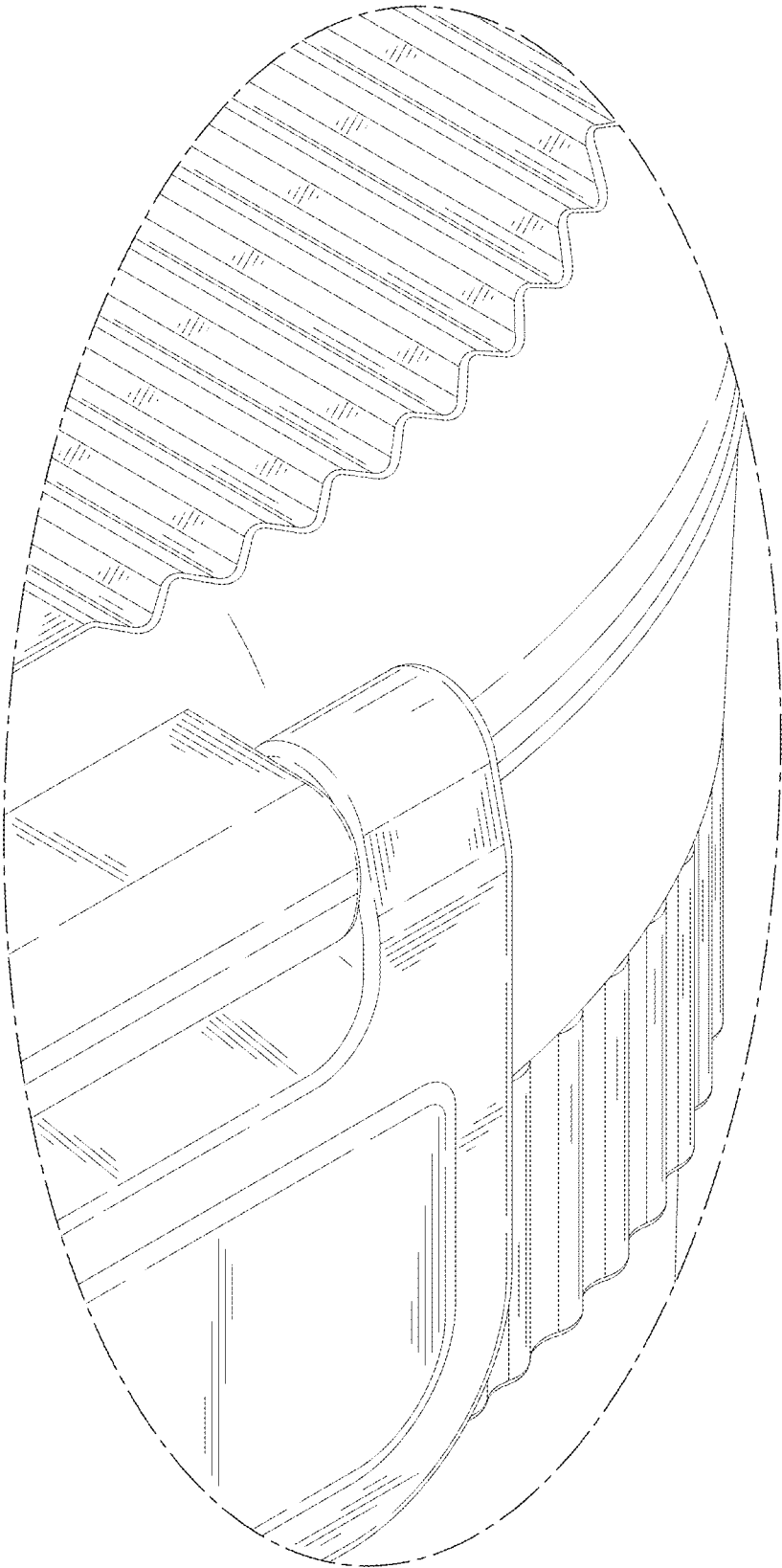

FIG. 9