



HU000026155T2

(19) **HU**(11) Lajstromszám: **E 026 155**(13) **T2****MAGYARORSZÁG**
Szellemi Tulajdon Nemzeti Hivatala**EURÓPAI SZABADALOM**
SZÖVEGÉNEK FORDÍTÁSA

- (21) Magyar ügyszám: **E 10 737123**
- (22) A bejelentés napja: **2010. 06. 18.**
- (96) Az európai bejelentés bejelentési száma:
EP 20100737123
- (97) Az európai bejelentés közzétételi adatai:
EP 2488359 A1 **2010. 12. 23.**
- (97) Az európai szabadalom megadásának meghirdetési adatai:
EP 2488359 B1 **2015. 10. 14.**
- (51) Int. Cl.: **B30B 11/24** (2006.01)
B29C 47/38 (2006.01)
B30B 15/30 (2006.01)
C10L 5/36 (2006.01)
C10L 5/44 (2006.01)
B30B 15/34 (2006.01)
B29C 47/60 (2006.01)
- (86) A nemzetközi (PCT) bejelentési szám:
PCT/PL 10/000049
- (87) A nemzetközi közzétételi szám:
WO 10147493

(30) Elsőbbségi adatok: 38831409 2009. 06. 18. PL	(74) Képvisező: PINTZ ÉS TÁRSAI Szabadalmi, Védjegy és Jogi Iroda Kft., Budapest
(72) (73) Feltalálók) és szabadalmas(ok): Junczyk, Adam Piotr, 21-500 Biala Podlaska (PL)	

(54) **Eljárás brikett készítésére aprított szalmából, és készülék brikett előállítására**

Az európai szabadalom ellen, megadásának az Európai Szabadalmi Közlönyben való meghirdetésétől számított kilenc hónapon belül, felszólalást lehet benyújtani az Európai Szabadalmi Hivatalnál. (Európai Szabadalmi Egyezmény 99. cikk(1))

A fordítást a szabadalmas az 1995. évi XXXIII. törvény 84/H. §-a szerint nyújtotta be. A fordítás tartalmi helyességét a Szellemi Tulajdon Nemzeti Hivatala nem vizsgálta.



(11) **EP 2 488 359 B1**

(12) **EUROPEAN PATENT SPECIFICATION**

(45) Date of publication and mention of the grant of the patent:
14.10.2015 Bulletin 2015/42

(21) Application number: **10737123.9**

(22) Date of filing: **18.06.2010**

(51) Int Cl.:
B30B 11/24 ^(2006.01) **B30B 15/30** ^(2006.01)
B30B 15/34 ^(2006.01) **C10L 5/44** ^(2006.01)
C10L 5/36 ^(2006.01) **B29C 47/38** ^(2006.01)
B29C 47/60 ^(2006.01)

(86) International application number:
PCT/PL2010/000049

(87) International publication number:
WO 2010/147493 (23.12.2010 Gazette 2010/51)

(54) **METHOD FOR MAKING BRIQUETTES FROM COMMINUTED STRAW AND A DEVICE TO PRODUCE BRIQUETTES**

VERFAHREN ZUR HERSTELLUNG VON PRESSLINGEN AUS ZERKLEINERTEM STROH UND VORRICHTUNG ZUR HERSTELLUNG VON PRESSLINGEN

PROCÉDÉ DE FABRICATION DE BRIQUETTES À PARTIR DE PAILLE BROYÉE ET DISPOSITIF DE PRODUCTION DE BRIQUETTES

(84) Designated Contracting States:
AL AT BE BG CH CY CZ DE DK EE ES FI FR GB GR HR HU IE IS IT LI LT LU LV MC MK MT NL NO PL PT RO SE SI SK SM TR

(30) Priority: **18.06.2009 PL 38831409**

(43) Date of publication of application:
22.08.2012 Bulletin 2012/34

(73) Proprietor: **Junczyk, Adam Piotr**
21-500 Bia a Podlaska (PL)

(72) Inventor: **Junczyk, Adam Piotr**
21-500 Bia a Podlaska (PL)

(74) Representative: **Belz, Anna et al**
Polnocna 6/24
20-064 Lublin (PL)

(56) References cited:
EP-A1- 1 193 045 WO-A1-00/18572
WO-A1-87/05619 WO-A2-2009/006752
AT-B- 401 525 CA-A1- 2 587 025
DE-B3- 10 254 373 GB-A- 2 269 131

- **Che Zhanbin: "Normal Temperature Briquetting Technology for Biomass with Original Moisture Content", International Conference on Bioenergy Utilization and Environment Protection 6th LAMNET Workshop - Dalian, China 2003, 7 September 2004 (2004-09-07), pages 1-6, XP055054601,**
- **GROVER P D ET AL: "BIOMASS BRIQUETTING: TECHNOLOGY AND PRACTICES Passage", 1 April 1996 (1996-04-01), BIOMASS BRIQUETTING: TECHNOLOGY AND PRACTICES, FOOD AND AGRICULTURAL ORGANIZATION OF THE UNITED NATIONS, PAGE(S) I-V, XP003025658,**

Remarks:

The file contains technical information submitted after the application was filed and not included in this specification

Note: Within nine months of the publication of the mention of the grant of the European patent in the European Patent Bulletin, any person may give notice to the European Patent Office of opposition to that patent, in accordance with the Implementing Regulations. Notice of opposition shall not be deemed to have been filed until the opposition fee has been paid. (Art. 99(1) European Patent Convention).

EP 2 488 359 B1

Description**Technical Field**

[0001] The subject of the present invention is a method for making briquettes from comminuted straw and a device for producing briquettes from comminuted plant waste.

Prior Art

[0002] Known methods for making briquettes from comminuted plant feedstock rely on compressing the raw material in a screw-type extruder while heating the extruder barrel and the forming die using electric heaters. During the compression the material solidifies, with the outer layer of a briquette formed having the most compact structure. In order to reduce cross-sectional heterogeneity of the resulting end product, the product is made in the form of a cylinder with a central hollow.

[0003] Polish patent No 198907 discloses a screw-type briquetting machine having a screw consisting of two segments, the first of which, counting from the inlet has a greater diameter and helix pitch than the other one which serves as a densifying segment of the screw. The barrel working chamber and the die are heated. Fitted at the face of the forming die is an annular die with a guide with pressure control. The screw is supported on bearings and actuated through an electric motor and a gearbox. The extruder barrel is equipped with a chute to supply the feedstock from a hopper.

[0004] International publication WO 2009/006752 discloses a method for producing a sausage type profiles from biomass material in which the biomass material is pre-dried to a moisture content of 20-35%, is fed to a screw-type extruder and then compressed, whereas in the compression region the biomass material has a temperature within the range between 100 to 130°C. The device disclosed in WO 2009/006752 is a screw-type extruder comprising a screw disposed in a barrel ended with a forming die.

[0005] Canadian patent application No CA 2587025 discloses a method for producing a firelog from a flax straw derivative, like flax shives, in which the flax straw derivative is pre-dried to a moisture content of about 4%, is fed to a screw-type extruder and then compressed, and in the compression region the flax straw derivative has a temperature within the range between about 150 to 180°C. The end product has a specific gravity of about 1.25. The device disclosed in CA 2587025 is a screw-type extruder comprising a screw disposed in a barrel ended with a forming die. The barrel is surrounded with an internal cooling jacket.

[0006] United Kingdom patent application No GB 2269131 discloses a method for producing a dense solid from biomass, like straw, in which the biomass is fed to a device comprising a rotating screw impeller without any pre-drying step and then compressed. The device does

not comprise any forming die. The final product has a density in excess of 1 g/cm³.

Summary of Invention

[0007] According to the present invention, comminuted straw, pre-dried to a moisture content between 15 to 25%, is fed to a screw extruder and then gradually compressed until it reaches a temperature above 290°C and a density above 1.3 g/cm³, and the resulting mass is extruded in a continuous process in the form of a cylinder with a uniform structure. During the extrusion a constant temperature span is maintained at the die, not exceeding 340°C. Preferably, the mass resulting from such compression has a density in the range from 1,3 to 1,5 g/cm³.

[0008] The subject of the present invention is also a device for the manufacture of briquettes from comminuted straw, said device having disposed in the barrel a three-segment screw with different helix pitches, said segment pitches decreasing toward the outlet. The forming die, disposed downstream the screw, is housed in a tank connected via a water system to a pump and a fanned cooler.

[0009] Preferably, a temperature indicator and a temperature sensor are installed inside the tank, integrated into the supply system of the pump.

[0010] The barrel chute is connected to a hopper equipped with a screw feeder driven by a separate motor. The motor of the screw feeder is equipped with a rotation speed controller. Screw feeder helix mates the arms of a rotating scraper installed on an inclined wall of the hopper.

Advantageous Effects of Invention

[0011] The method according to the present invention allows obtaining briquettes with a uniform structure throughout the transverse cross section. The feedstock, heated uniformly throughout its mass has a stable form that does not change during long storage. In steam environment, the raw material is converted into compact briquettes. This process of briquette manufacture results in obtaining a 100% natural and ecological fuel. Since the final product is characterized by a compact structure, its combustion is a process of long duration.

[0012] The briquetting device according to the present invention is energy-efficient, because attaining the right temperature does not require any heaters. The hopper ensures continuous and uniform feeding of the raw material in the form of comminuted straw. The device is also able to operate at negative temperatures.

[0013] In particular, the objects are achieved by a method according to claim 1, and a device according to claim 2. Preferred embodiment is subject of dependent claim 3.

Description of Embodiments

Example 1.

[0014] First, comminuted rye straw was prepared in a comminutor, then the straw was pre-dried to 20% moisture and fed to the briquetting machine's hopper. After the hopper had been filled with the comminuted straw, the screw feeder and the extruder screw were started simultaneously. The straw was gradually compressed. Screw rotation speed was initially set at 5 rpm and the machine operated at that speed until steam appeared at the outlet of guide 10, then the speed was increased to 25 rpm. During the operation of the extruder screw, the temperature of the raw materials was rising. Initially, the stabilizing sleeve produced incompletely solidified briquettes. After 5 minutes, as a result of temperature rise, the outgoing product in cylindrical form had reached the density of 1.3 g/cm³. The temperature sensor of the cooling system was set at 50°C. After that value had been exceeded, the cooling system pump was started. Further, the process ran in a continuous mode, provided that the material in the hopper was made-up when necessary. In case that excessive accumulation of raw material is found at the hopper outlet, the rotation speed of the screw feeder driving motor is reduced.

Example 2.

[0015] Comminuted straw, pre-dried to 15% moisture, was fed to the briquetting machine's hopper and processed like in Example 1. The product obtained in the form of a cylinder had a density of 1.4 g/cm³.

Example 3.

[0016] A device for the manufacture of briquettes is reproduced, as an example, in the enclosed drawing in which Fig. 1 shows the device in partial cross section along the axis of the barrel, and Fig. 2 is a side view with a section of the hopper.

[0017] Inside the barrel **1** which is seated on a foundation **2** there is disposed a screw **3** whose shaft **4**, supported on bearings **5**, is driven by an electric motor **6** through a belt transmission **7**. The screw **3** has three helix segments of decreasing pitch toward the outlet. Bolted at the face of the barrel **1** is a forming die **8** having a conical bore, which is connected to a stabilizing sleeve **9**. The stabilizing sleeve **9** has a guide **10** attached to it. The forming die **8** is housed in a cooling liquid tank **11** which is connected through the water system **12** to a fanned cooler **13** equipped with a fan **14**. The water system **12** is equipped with a pump **15** and a temperature indicator **16**, while at the tank **11** a temperature sensor **17** is installed which is part of the supply system of the pump **15**. The barrel **1** has a chute **18** connected to a hopper **19**, at the bottom of which there is a screw feeder **20** driven by an electric motor **21** while on an inclined

wall of hopper **19** a rotary scraper **22** is installed whose ends mate the helix of the screw feeder **20**.

5 Claims

1. Method for making briquettes from cereal straw which is comminuted and then pressed, **characterized in that** the comminuted straw, pre-dried to a moisture content of 15-25%, is fed to a screw-type extruder that does not comprise any heaters and then gradually compressed until it reaches a temperature above 290°C and density above 1.3 g/cm³, and the resulting mass is extruded in the form of a cylinder having a homogeneous structure.
2. A device for the manufacture of briquettes from comminuted straw, having a screw supported on bearings at its base, composed of segments of different helix pitches disposed in a barrel ended with a forming die, downstream which die a guide is disposed, and above the barrel there is a raw material hopper, **characterized in that** the screw (**3**) consists of three segments of decreasing helix pitches toward the outlet, while the forming die (**8**) is housed in a tank (**11**) connected through a water system (**12**) to a cooler (**13**) which has a fan (**14**), and a chute (**18**) at the barrel (**1**) is connected with the hopper (**19**) inside which there is a screw feeder (**20**) driven by a motor (**21**), and on an inclined wall of the hopper (**19**) a rotary scraper (**22**) is mounted whose arm ends mate the helix of the screw feeder (**20**), wherein the device does not comprise any heaters.
3. The device according to claim 2, **characterized in that** in the tank (**11**) there is installed a temperature sensor (**17**) which is part of the pump supply circuit (**15**) of the water system (**12**).

40 Patentansprüche

1. Herstellungsweise von Briketten aus Getreidestroh, das zum Häcksel geschnitten und dann gepresst wird, **dadurch gekennzeichnet, dass** das bis zur Feuchtigkeit von 15-25 ° vorgetrocknete Häcksel in eine Schneckenpresse, die keine Vorwärmer aufweist, eingeführt und anschließend zusammengedrückt wird, bis es eine Temperatur von mehr als 290° und eine Dichte von mehr als 1,3 g/cm erreicht, wobei die entstandene Masse in Form von einer Welle mit homogener Struktur ausgepresst wird.
2. Die Vorrichtung für Herstellung von Briketten aus Getreidestroh, welche eine in der Unterlage gelagerte Schnecke aufweist, die sich aus Segmenten mit diversen Windungssprüngen zusammensetzt und in einem mit der formenden Hülse abgeschlossenen

Zylinder untergebracht wird, wobei hinter der Hülse eine Führung und über dem Zylinder ein Rohstoffspeicher angeordnet sind, **dadurch gekennzeichnet, dass** die Schnecke (3) aus drei Segmenten mit einem sich zum Austritt verringernden Windungsmaßstab besteht und die formende Matrize (8) mit einem durch die Wasseranlage (12) mit einem Kühler (13) verbundenen Behälter (11) umbaut wird, wobei am Kühler (13) ein Ventilator (14) angeordnet ist und die Beschickung (18) des Zylinders (1) mit dem Speicher (19) verbunden wird, in dem sich eine mit dem Motor (21) getriebene Förderschnecke (20) befindet und an der geneigten Wand des Speichers (19) wird drehbar ein Abstreifer (22) montiert, dessen Schenkeln mit den Windungen der Förderschnecke (20) verzahnt werden, wobei die Vorrichtung keine Vorwärmer aufweist.

3. Die Vorrichtung nach dem Anspruch 2, **dadurch gekennzeichnet, dass** im Behälter (11) ein Temperaturfühler (17) installiert wird, der in den Kreis der Pumpenspeisung (15) der Wasseranlage (12) eingeschaltet ist.

ne contient pas d'éléments chauffants.

3. Dispositif selon la revendication 2, **caractérisé en ce que** dans le réservoir (11) est installé un capteur de température (17), qui est incorporé dans le circuit d'alimentation de la pompe (15) du réseau d'eau (12).

Revendications

1. Procédé pour la fabrication de briquettes de paille de blé, qui est découpée en paille hachée et ensuite comprimée, **caractérisé en ce que** la paille hachée est préséchée à l'humidité de 15 à 25% et puis elle est amenée à une extrudeuse à vis qui ne contient pas d'éléments de chauffage et ensuite est comprimée progressivement jusqu'à ce qu'elle atteigne la température au-dessus de 290°C et la densité au-dessus de 1,3 g/cm, et la masse résultante est extrudée sous la forme d'un cylindre avec une structure homogène.
2. Dispositif pour la fabrication de briquettes de paille hachée ayant une vis sans fin montée dans une base, consistante en segments avec différents pas de filetage et disposée dans un cylindre terminée par une douille de formage, suivie d'un guide, et avec le réservoir pour la matière première monté sur le cylindre, **caractérisé en ce que** la vis sans fin (3) se compose de trois sections avec la diminution de pas de vis vers de sortie, et une matrice de formage (8) est fermée dans le réservoir (11) relié par un réseau d'eau (12) au condenseur (13), accompagné par le ventilateur (14), et où l'élément d'alimentation (18) du cylindre (1) est relié à la trémie (19), dans laquelle est le dispositif de la vis sans fin d'alimentation (20) entraîné par un moteur (21), et sur la paroi inclinée de la trémie (19) est monté de façon pivotante le racloir (22), ses extrémités des bras sont engrenées au filet du dispositif de la vis sans fin d'alimentation (20), et le dispositif pour la fabrication de briquettes

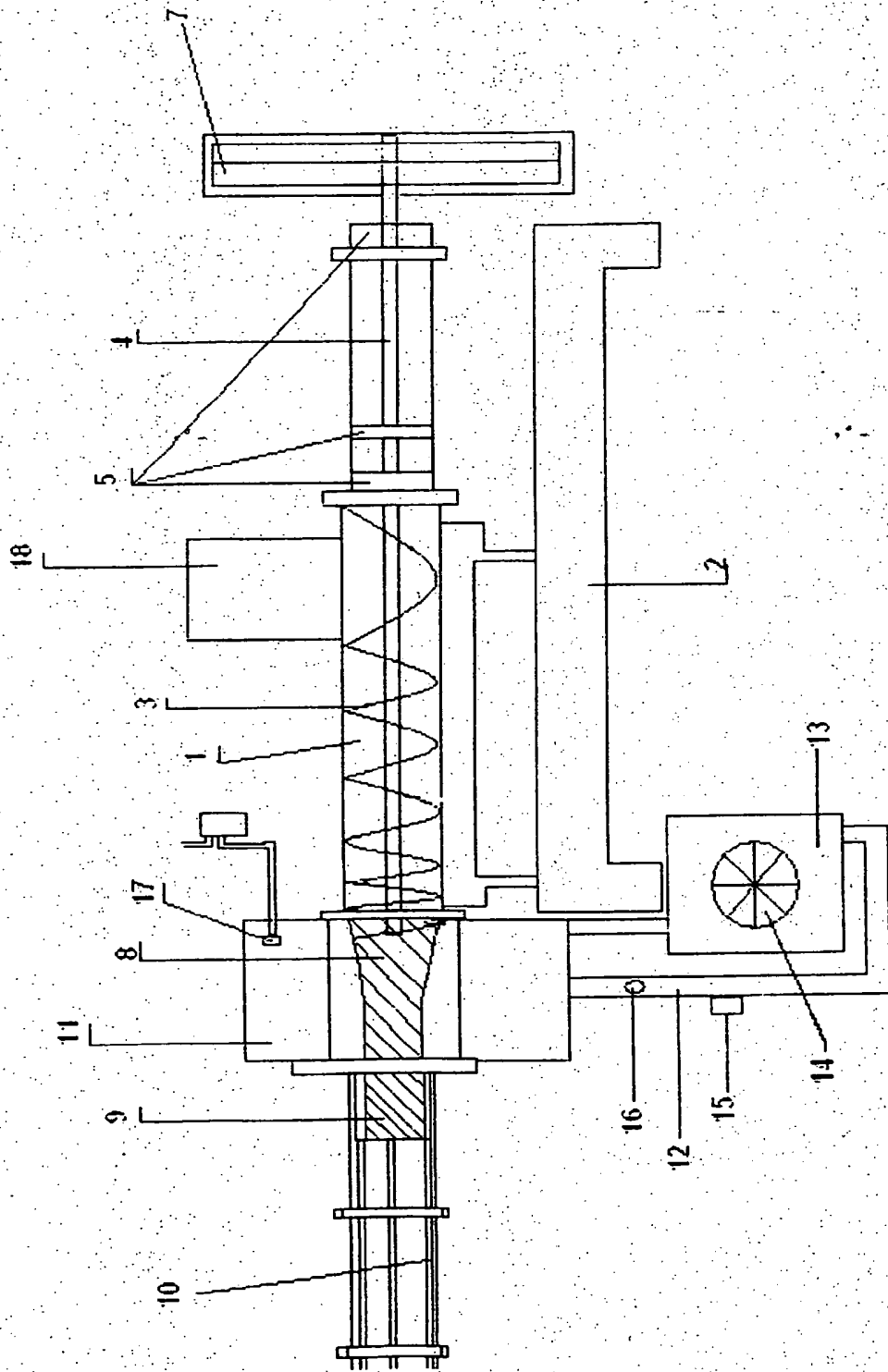

Fig. 1

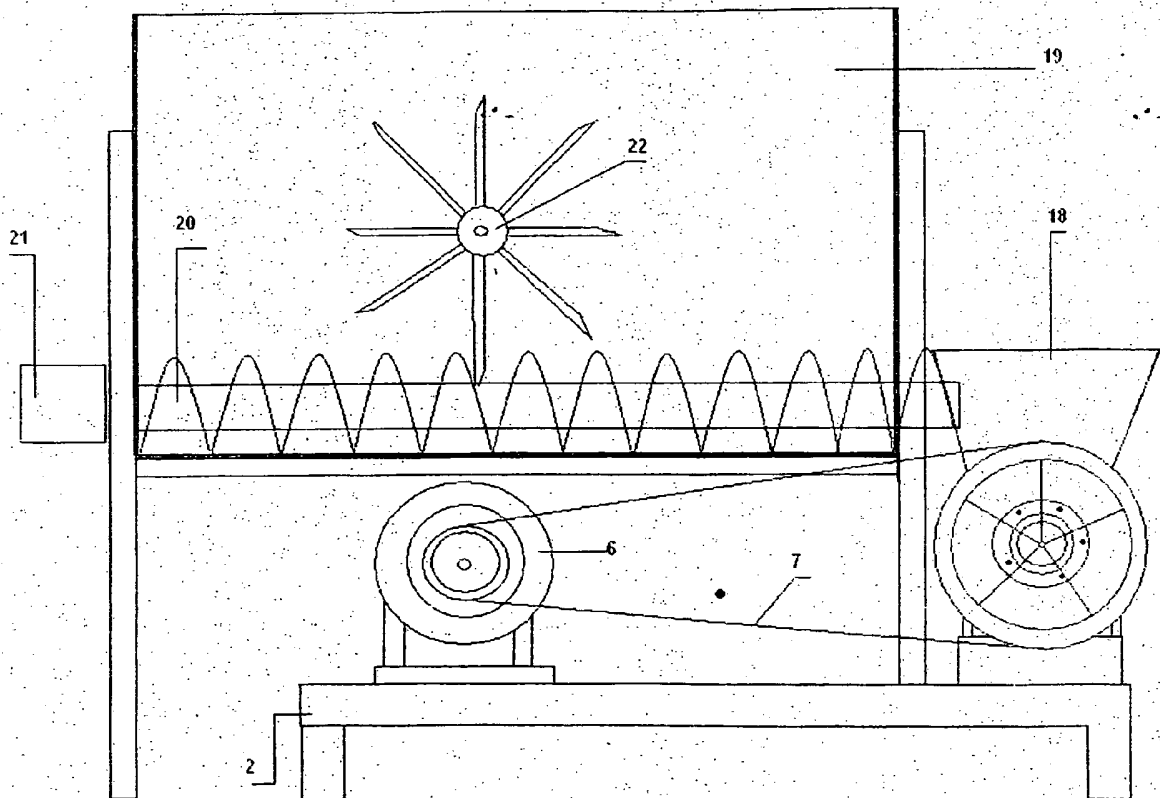

FIG. 2

REFERENCES CITED IN THE DESCRIPTION

This list of references cited by the applicant is for the reader's convenience only. It does not form part of the European patent document. Even though great care has been taken in compiling the references, errors or omissions cannot be excluded and the EPO disclaims all liability in this regard.

Patent documents cited in the description

- PL 198907 [0003]
- WO 2009006752 A [0004]
- CA 2587025 [0005]
- GB 2269131 A [0006]

ELJÁRÁS BRIKETT KÉSZÍTÉSÉRE APRÍTOTT SZALMÁBÓL, ÉS KÉSZÜLÉK BRIKETT ELŐÁLLÍTÁSÁRA
SZABADALMI IGENYPONTOK

1. Eljárás brikket készítésére gabonaszalmából, amely aprítva van, majd össze van préselve, azzal jellemelve, hogy a 15-25% nedvességtartalomra előszárított aprított (comminuted) szalmát betápláljuk egy csigásprés-típusú (screw-type) extrudáló készülékbe, amely nem tartalmaz semmiféle hevítőelemet (heater), majd fokozatosan préseljük addig, amíg ez elér egy 230° feletti hőmérsékletet és 1,3 g/cm³ feletti sűrűséget, és a létrejövő masszát extrudáljuk homogén szerkezettel bíró henger formájában.

2. Készülék brikket gyártására aprított szalmából, amely készülék rendelkezik egy csapágyakkal (bearing) alapjánál megtámasztott csavarral (screw), és ez különböző ívmelkedésű (helix pitch) szegmensekből van összeállítva egy olyan hüvelyben (barrel) elrendezve, amely egy alaknyomó szerszámmal (forming die) végződik; a szerszámtól lefelé (downstream) egy vezető (guide) van elrendezve, és a hüvely felett van egy nyersanyag tartály (hopper), azzal jellemelve, hogy a csavar (3) a kimenet (outlet) felé csökkenő (decreasing) ívmelkedések (helix pitch) három szegmenséből áll, miközben az alaknyomó szerszám (8) egy tankban (11) helyezkedik el, amely tank egy vízrendszeren (water system) (12) keresztül hozzá van kapcsolva egy hűtőberendezéshez (cooler) (13), amelynek van egy ventilátora (fan) (14); és egy garat (chute) (18) a hüvelynél (1) összeköttetésben van a tartállyal (hopper) (19), amelyen belül van egy motor (21) által hajtott csigás adagoló (screw feeder) (20); és a tartály (19) egyik ferde (inclined) falára egy forgó kaparó (rotary scraper) (22) van felszerelve, amelynek karvégei egyesülnek a csigás adagoló (20) csavarfelületével (helix); ahol a készülék nem tartalmaz semmiféle hevítőelemet (heater).

3. A 2. igénypont szerinti készülék, azzal jellemelve, hogy a tankban (11) be van állítva egy hőmérséklet-érzékelő (temperature sensor) (17), amely a vízrendszer (12) szivattyú szolgáltató körének (pump supply circuit) (15) egy része.