

Feb. 7, 1928.

1,658,068

A. WHITE

WHEELED TOY

Filed Sept. 15, 1924

2 Sheets-Sheet 1

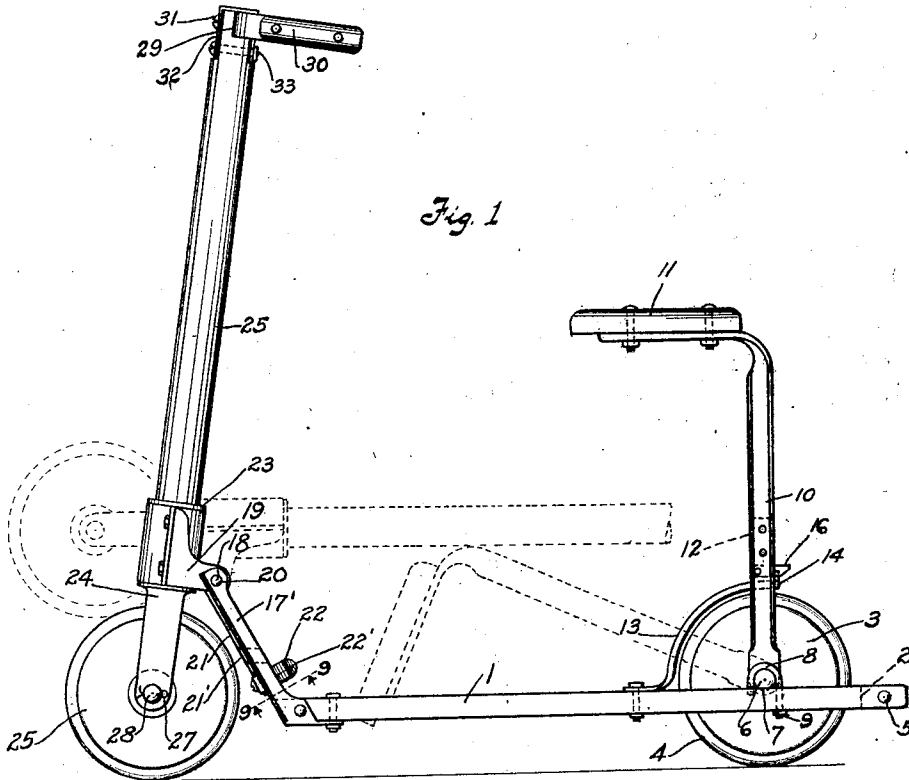

Fig. 1

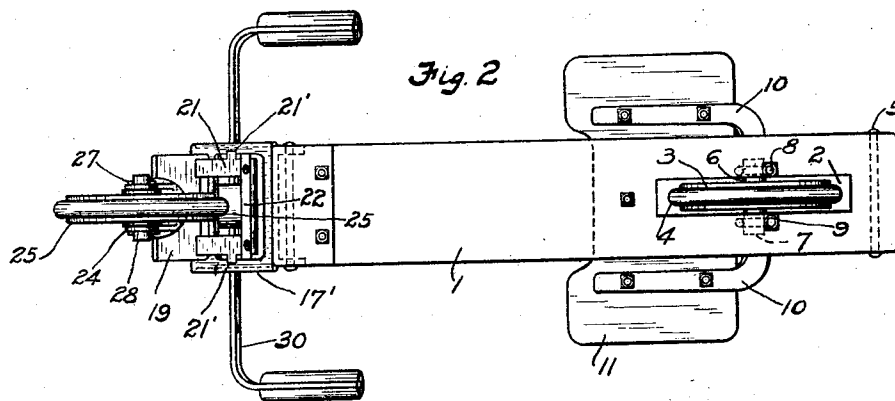

Fig. 2

INVENTOR.

Arthur White

BY

Morsell, Keeney and Morsell

ATTORNEYS.

Feb. 7, 1928.

1,658,068

A. WHITE
WHEELED TOY

Filed Sept. 15, 1924

2 Sheets-Sheet 2

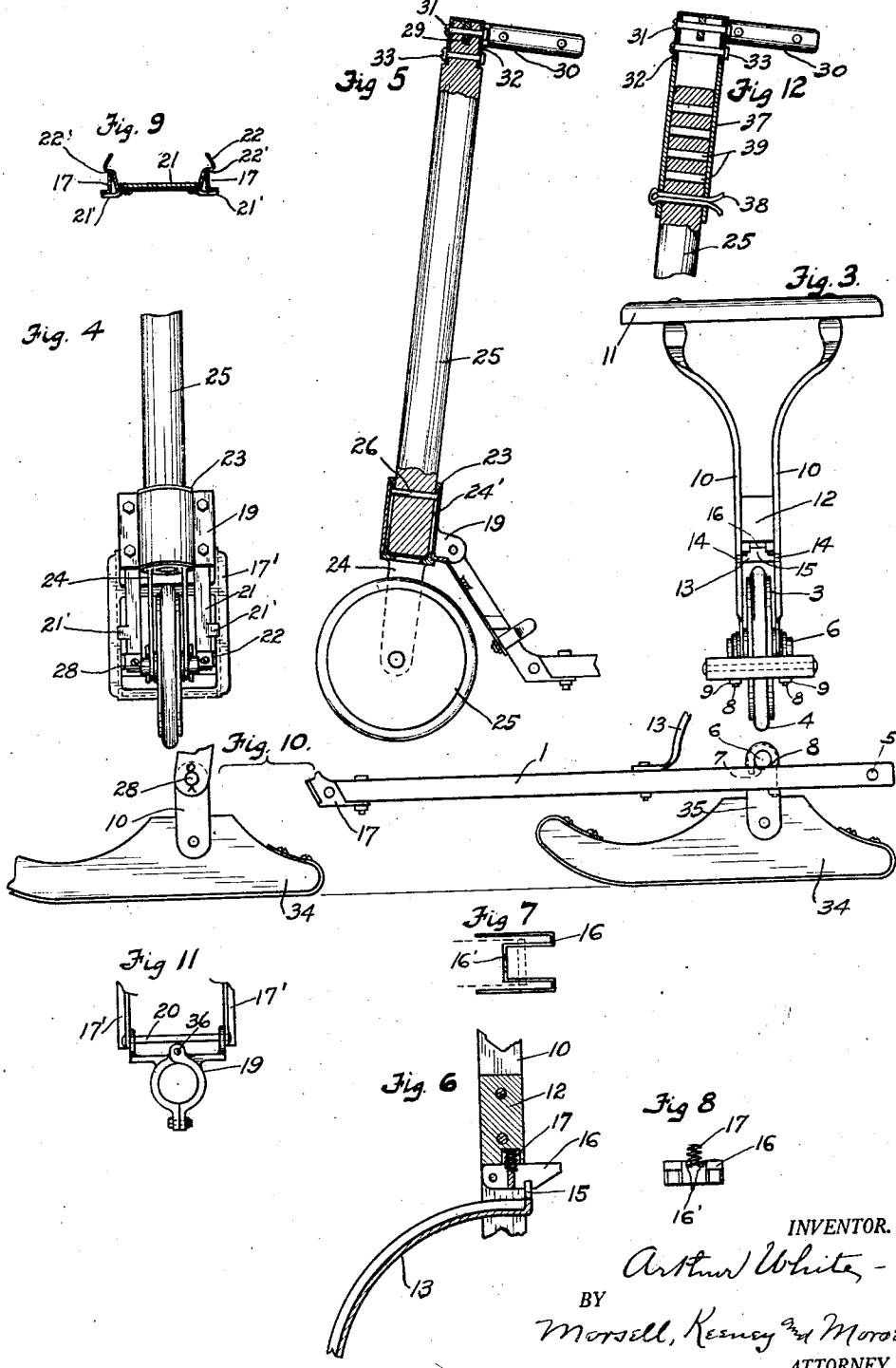

INVENTOR.

Arthur White -

BY
Morsell, Keesey and Morsell.
ATTORNEY.

UNITED STATES PATENT OFFICE.

ARTHUR WHITE, OF SHEBOYGAN FALLS, WISCONSIN.

WHEELED TOY.

Application filed September 15, 1924. Serial No. 737,805.

The invention relates to wheeled toys.

It is one of the objects of the present invention to provide a wheeled toy of the bicycle type which may be formed in greater part of wood, and in which the parts are manufactured and assembled in an easy manner to form a strong, simple and inexpensive toy for children.

A further object of the invention is to provide a wheeled toy of the bicycle type upon which a child may sit and propel by pushing on the walk with the feet.

A further object of the invention is to provide a wheeled toy in which the seat and its support and the steering post and handles may be easily folded downwardly to positions adjacent the foot or body board of the toy, so that the toy will occupy a minimum amount of space when not in use.

A further object of the invention is to provide a wheeled toy in which the foldable parts are automatically and rigidly locked in upright usable position.

A further object of the invention is to provide a wheeled toy in which runners may be substituted for the wheels to form a sled.

A further object of the invention is to provide a wheeled toy in which the parts are assembled in a manner to reinforce each other.

A further object of the invention is to provide a wheeled toy which is of simple construction, is strong and durable, and is well adapted for the purpose described.

With the above and other objects in view, the invention consists of the improved wheeled toy and its parts and combinations as set forth in the claims, and all equivalents thereof.

In the accompanying drawings in which the same reference characters indicate the same parts in all of the views:

Fig. 1 is a side view of the improved wheeled toy with the parts shown in open position, the view also showing the parts in folded position;

Fig. 2 is an inverted view thereof;

Fig. 3 is a view of the rear end portion of the toy;

Fig. 4 is a front detail view of the lower portion of the steering post;

Fig. 5 is a side view, partly in section, of the steering post and wheel;

Fig. 6 is a sectional detail view of the seat post and locking mechanism;

Fig. 7 is a top detail view of the seat post locking member;

Fig. 8 is a rear view thereof showing the manner of mounting the spring;

Fig. 9 is a sectional detail view of the steering post connection taken on a larger scale on line 9—9 of Fig. 1;

Fig. 10 is a side view of the lower portion of the toy showing sleigh runners substituted for the wheels;

Fig. 11 is a detail top view of the steering post connection; and

Fig. 12 is a sectional detail view of a modification of the upper portion of the steering post.

Referring to the drawings, the numeral 1 indicates the foot board or member forming a portion of the frame of the improved toy, which extends horizontally, and its rear end portion is formed with an elongated slot 2 to receive a rear wooden wheel 3. Said wheel may have a rubber tire 4 mounted thereon, if desired. A bolt or rivet 5 reinforces the slotted end portion of the board. The axle 6 upon which the wheel 3 is journaled is of less length than the width of the foot board, and is recessed into the upper surface of the board, as indicated by the numeral 7 to prevent endwise movement of said shaft. Hook bolts 8 extend around the end portions of the shaft, and the shank portions extend downwardly through the foot board and have nuts 9 threaded on their ends to draw the axle ends firmly into engagement with the board and the recesses 7, to prevent endwise movement of the axle. The axle also extends through openings in the ends of metal channel frame bars 10 which are positioned on opposite sides of the wheel 3 and the inner side edges of the slotted portions of the board and extend upwardly therefrom. The upper end portions of the bars 10 are flattened and extend forwardly and have a seat 11 mounted thereon. A block 12 holds the seat support or bars 10 in spaced relation and said support may be swung forwardly and downwardly to rest on the board 1, the axle 6 serving as a fulcrum. A curved guard member 13 fastened to the foot board 1 and extending upwardly and rearwardly in front of the wheel 4, passes between the seat bars 10, and at its rear end is formed with lateral stop projections 14 which limit the rearward swing of the seat bars. The rear end of the guard is also provided with a shoulder 15

which is engaged by latch 16 positioned between and pivoted to the seat bars 10 to lock the said seat bars in upright position. A coiled spring 17 recessed into the block 12 and bearing in notched portions 16' of the latch 16 yieldingly holds the latch in locking position, so that when the seat is swung upwardly the latch will ride on the guard and the beveled free end of the latch will engage and ride upwardly on the shoulder 15 and automatically snap into locking position.

The forward end portion of the foot board has rigidly connected thereto a metal bifurcated bracket member 17' which is formed with eyes 18 at its upper end. A steering fork member 19 extends between the bifurcations of the bracket member 17' and is hinged thereto by a transverse pivot bolt 20 to permit the fork member 19 to swing rearwardly and downwardly towards the foot board. The fork member is also provided with a downward extension 21 which extends between the bifurcations of the bracket 17' and is formed with stop projections 21' to limit the movement of the fork member with relation to the bracket member. A spring latch 22 mounted on the extension 21 is formed with shoulders 22' which are adapted to extend between the bifurcations of the bracket member 17' and automatically snap over the edges thereof into locking position shown in Fig. 9. To unlock, it is only necessary to press the end portions of the latch 22 towards each other.

The fork member 19 is formed of two parts bolted together to extend around the shouldered bearing 23 of the steering fork 24. Said fork carries a steering wheel 25 at its lower end and at its upper end is in the form of a socket 24' for receiving the lower end portion of a wooden steering post 25. A transverse pin 26 firmly secures the post to the steering fork socket while cotter pins 27 extending through the steering wheel axle 28 hold said axle against endwise movement in the steering fork.

The upper end portion of the steering post is provided with a transverse slot 29 for receiving the metal strip of the steering handle 30 and a bolt 31 extends through the strip and the post and secures the parts together. The upper end of the post is reinforced by a metal strip 32 through which the bolt 31 also extends. Said strip is further connected to the post by a bolt 33.

Sleigh runners 34 having upwardly extending eyed straps 35 are adapted to be substituted for the wheels 3 and 25 by simply removing the wheels from the axles and mounting the eyed straps of the runners thereon, as shown in Fig. 10, when it is desired to use the toy on snow or ice.

Fig. 11 shows a slightly modified form of steering fork in which the joint between

the two sections of the fork is formed longitudinally of the foot board and the rear portion is joined together by a hinge pin 36. As shown in Fig. 12, the upper end of the post 25 is modified to permit vertical adjustment thereof by providing a telescoping member 37 which extends over the post end and fastened thereto by a cotter pin 38. Said post end is formed with a number of pin openings 39 to receive the pin in adjusting the height of the handle member.

While the construction shown is provided with spring latches, it is to be understood that other kinds of latches or locks may be used to secure the seat support and the steering post in upright position.

From the foregoing description, it will be seen that the wheeled toy may be inexpensively manufactured in greater part from wood, and that a very strong durable structure is provided due to the novel arrangement of parts which permit folding the toy when not in use.

What I claim as my invention is:

1. A wheeled toy, comprising a foot board, a seat member pivotally connected to one end portion thereof and having a supporting member for the rear end portion of the board, a bracket member connected to the forward end portion of the board and extending forwardly therefrom, a steering member pivotally connected to the front end of the bracket member and having a supporting member at its lower end portion, said steering member also having means for locking said member in upright position, both the seat member and the steering member being foldable to positions toward each other and the foot board, a guard member mounted at one end on the foot board and extending above the rear supporting member, and means for locking the seat member in its upper position to said guard member.

2. A wheeled toy, comprising a foot board having an elongated slot in its rear portion, an axle connected to said board and extending transversely of the slot, a wheel extending into said slot and journaled on said axle, a seat member pivotally connected to the axle and having a seat mounted on its upper end portion, a bracket member connected to the forward end portion of the board and extending forwardly therefrom, and a steering fork pivotally connected to the front upper end portion of the bracket member and having a steering wheel journaled in its lower end portion and having a steering means at its upper end portion, both the seat member and the steering fork being foldable to positions toward each other and the foot board.

3. A wheeled toy, comprising a foot board having an elongated slot in its rear portion, a supporting wheel within and having a

journal connection with the slotted portion of the board, a bracket member connected to the forward end portion of the board and extending forwardly therefrom, a seat member pivotally connected to the foot board and movable concentrically with relation to the axis of the supporting wheel and having a seat at its upper end portion, a guard member mounted at one end on the foot board and curving upwardly and rearwardly in front of the supporting wheel, a steering member connected to the front end of the bracket-member and having a supporting wheel at its lower end portion, both the seat member and the steering member being foldable to positions toward each other and the foot board, and means for locking the said members in their upper positions, the seat member being locked to the guard member.

4. A wheeled toy, comprising a foot board having an elongated slot in its rear portion, an axle extending transversely of the slot and connected thereto, a wheel within the slot and journaled on the axle, a seat member pivotally connected to the axle and having a seat at its upper end, a bracket member connected to the forward end portion of the board and extending forwardly therefrom, a steering fork member pivotally connected to the front upper end portion of the bracket member and having a handle means at its upper end portion, a wheel journaled in the lower end portion of the steering fork, means for locking the seat member in its upper position, and means for locking the steering fork member in its upper position, both the seat member and the steering fork member when unlocked being foldable toward each other and the foot board.

5. A wheeled toy, comprising a foot board having an elongated slot in its rear portion, an axle extending transversely of the slot, means connecting the axle to the foot board, a wheel within the slot and journaled on the axle, a seat member pivotally connected to the axle on opposite sides of the wheel and extending upwardly therefrom and having a seat at its upper end portion, a guard member mounted on the foot board and extending upwardly therefrom, a latch means for locking the seat member to the guard member when the seat member is in its upper position, a bracket member mounted on the front end portion of the foot board, a steering fork member pivoted to the bracket member, means for locking the steering fork member to the bracket member, a steering fork turnably mounted in the steering fork member and having a steering handle at its upper end, and a wheel journaled in the

lower end of the steering fork, said seat member and steering fork member being foldable toward the foot board.

6. A wheeled toy, comprising a foot board having an elongated slot in its rear portion, an axle extending transversely of the slot, means connecting the axle to the foot board, a wheel within the slot and journaled on the axle, a seat member pivotally connected to the axle on opposite sides of the wheel and extending upwardly therefrom and having a seat at its upper end portion, a guard member mounted on the foot board and extending upwardly therefrom, a latch means for locking the seat member to the guard member when the seat member is in its upper position, a bracket member mounted on the front end portion of the foot board, a steering fork member pivoted to the bracket member, and having a downward extension which engages the bracket member to limit the forward movement of the steering fork member, latch means for locking the lower portion of the extension to the bracket member, a steering fork turnably mounted in the steering fork member and having a steering handle in its upper end, and a wheel journaled in the lower end portion of the steering fork, said seat member and steering fork member being foldable toward the foot board.

7. A wheeled toy, comprising a foot board having an elongated slot in its rear portion, an axle extending transversely of the slot, means connecting the axle to the foot board, a wheel within the slot and journaled on the axle, a seat member formed of metal bars which are pivotally connected to the axle on opposite sides of the wheel and extend upwardly therefrom in spaced relation, a seat member, a curved guard member mounted on the foot board and extending upwardly in front of the wheel and between the bars of the seat member and having stop means to limit the rearward movement of said seat member, a latch means carried by the bars and engaging the curved guard to lock the bars in upright position, a bracket member mounted on the front end portion of the foot board, a steering fork member pivoted to the bracket member, means for locking the steering fork member to the bracket member, a steering fork turnably mounted in the steering fork member and having a steering handle at its upper end, and a wheel journaled in the lower end of the steering fork, said seat member and steering fork member being foldable toward the foot board.

In testimony whereof, I affix my signature.

ARTHUR WHITE.