

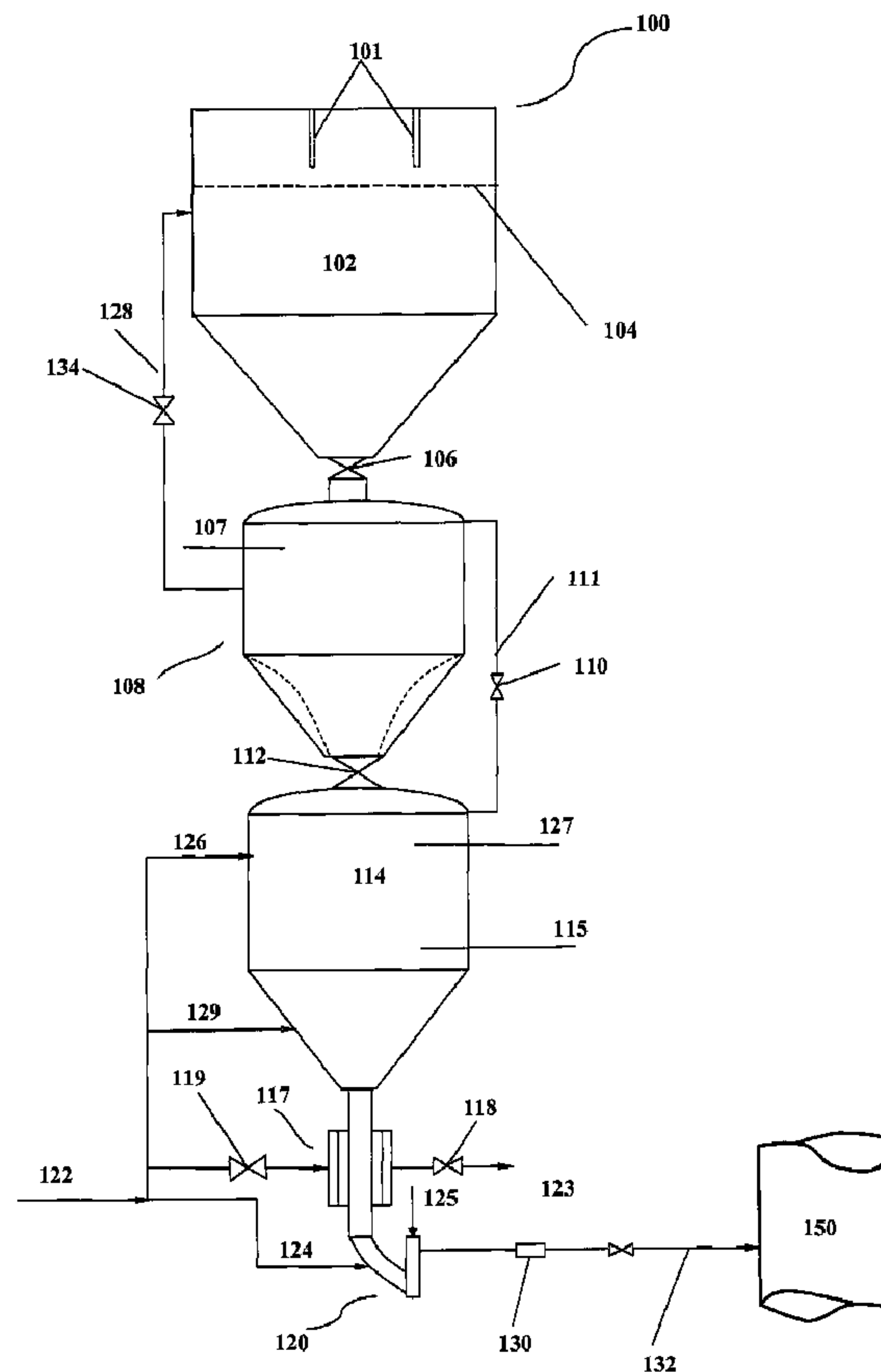

(86) **Date de dépôt PCT/PCT Filing Date:** 2010/12/20
 (87) **Date publication PCT/PCT Publication Date:** 2011/07/14
 (45) **Date de délivrance/Issue Date:** 2018/07/24
 (85) **Entrée phase nationale/National Entry:** 2012/06/21
 (86) **N° demande PCT/PCT Application No.:** US 2010/061271
 (87) **N° publication PCT/PCT Publication No.:** 2011/084737
 (30) **Priorités/Priorities:** 2009/12/21 (US61/288,534);
 2010/12/16 (US12/970,006)

(51) **Cl.Int./Int.Cl. C10J 3/50** (2006.01),
G05D 7/00 (2006.01)
 (72) **Inventeurs/Inventors:**
 VIMALCHAND, PANNALAL, US;
 PENG, WAN WANG, US;
 LIU, GUOHAI, US
 (73) **Propriétaire/Owner:**
 SOUTHERN COMPANY SERVICES, INC., US
 (74) **Agent:** NORTON ROSE FULBRIGHT CANADA
 LLP/S.E.N.C.R.L., S.R.L.

(54) **Titre : ALIMENTATEUR HAUTE PRESSION ET PROCEDE DE FONCTIONNEMENT POUR ALIMENTER EN MATIERES EN GRAINS OU FINES**
 (54) **Title: A HIGH PRESSURE FEEDER AND METHOD OF OPERATION TO FEED GRANULAR OR FINE MATERIALS**



(57) **Abrégé/Abstract:**

A coal feed system to feed pulverized low rank coals containing up to 25 wt% moisture to gasifiers operating up to 1000 psig pressure is described. The system includes gas distributor and collector gas permeable pipes imbedded in the lock vessel. Different

(57) Abrégé(suite)/Abstract(continued):

methods of operation of the feed system are disclosed to minimize feed problems associated with bridging and packing of the pulverized coal. The method of maintaining the feed system and feeder device exit pressures using gas addition or extraction with the pressure control device is also described.

(12) INTERNATIONAL APPLICATION PUBLISHED UNDER THE PATENT COOPERATION TREATY (PCT)

(19) World Intellectual Property Organization
International Bureau(43) International Publication Date
14 July 2011 (14.07.2011)(10) International Publication Number
WO 2011/084737 A3(51) International Patent Classification:
C10J 3/50 (2006.01) G05D 7/00 (2006.01)

(74) Agent: REDDY, Arvind R.; Thomas, Kayden, Horstemeier & Risley, LLP, 600 Galleria Parkway, Suite 1500, Atlanta, GA 30339-5948 (US).

(21) International Application Number:
PCT/US2010/061271

(81) Designated States (unless otherwise indicated, for every kind of national protection available): AE, AG, AL, AM, AO, AT, AU, AZ, BA, BB, BG, BH, BR, BW, BY, BZ, CA, CH, CL, CN, CO, CR, CU, CZ, DE, DK, DM, DO, DZ, EC, EE, EG, ES, FI, GB, GD, GE, GH, GM, GT, HN, HR, HU, ID, IL, IN, IS, JP, KE, KG, KM, KN, KP, KR, KZ, LA, LC, LK, LR, LS, LT, LU, LY, MA, MD, ME, MG, MK, MN, MW, MX, MY, MZ, NA, NG, NI, NO, NZ, OM, PE, PG, PH, PL, PT, RO, RS, RU, SC, SD, SE, SG, SK, SL, SM, ST, SV, SY, TH, TJ, TM, TN, TR, TT, TZ, UA, UG, US, UZ, VC, VN, ZA, ZM, ZW.

(22) International Filing Date:
20 December 2010 (20.12.2010)

(25) Filing Language: English

(26) Publication Language: English

(30) Priority Data:
61/288,534 21 December 2009 (21.12.2009) US
12/970,006 16 December 2010 (16.12.2010) US(71) Applicant (for all designated States except US):
SOUTHERN COMPANY SERVICES, INC. [US/US];
241 Ralph McGill Blvd., Atlanta, GA 30308 (US).

(84) Designated States (unless otherwise indicated, for every kind of regional protection available): ARIPO (BW, GH, GM, KE, LR, LS, MW, MZ, NA, SD, SL, SZ, TZ, UG, ZM, ZW), Eurasian (AM, AZ, BY, KG, KZ, MD, RU, TJ, TM), European (AL, AT, BE, BG, CH, CY, CZ, DE, DK, EE, ES, FI, FR, GB, GR, HR, HU, IE, IS, IT, LT, LU, LV, MC, MK, MT, NL, NO, PL, PT, RO, RS, SE, SI, SK, SM, TR), OAPI (BF, BJ, CF, CG, CI, CM, GA, GN, GQ, GW, ML, MR, NE, SN, TD, TG).

(72) Inventors; and

(75) Inventors/Applicants (for US only): VIMALCHAND, Pannalal [US/US]; 689 Highland Lakes Cove, Birmingham, AL 35242 (US). PENG, Wan, Wang [CN/US]; 944 Talon Way, Birmingham, AL 35242 (US). LIU, Guohai [US/US]; 1248 Eagle Park Road, Birmingham, AL 35242 (US).

[Continued on next page]

(54) Title: A HIGH PRESSURE FEEDER AND METHOD OF OPERATION TO FEED GRANULAR OR FINE MATERIALS

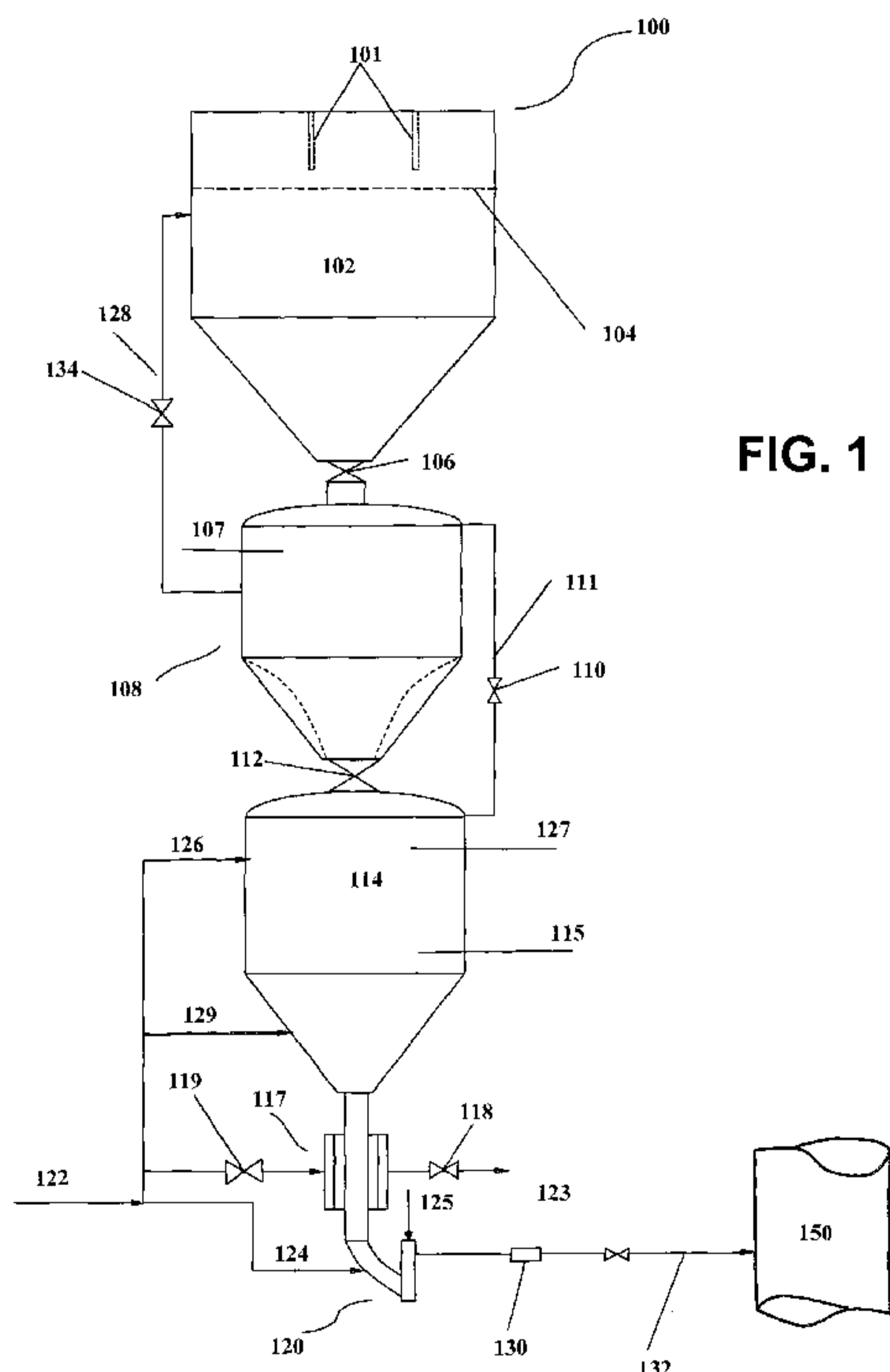

FIG. 1

(57) Abstract: A coal feed system to feed pulverized low rank coals containing up to 25 wt% moisture to gasifiers operating up to 1000 psig pressure is described. The system includes gas distributor and collector gas permeable pipes imbedded in the lock vessel. Different methods of operation of the feed system are disclosed to minimize feed problems associated with bridging and packing of the pulverized coal. The method of maintaining the feed system and feeder device exit pressures using gas addition or extraction with the pressure control device is also described.

WO 2011/084737 A3

WO 2011/084737 A3 

Published:

- *with international search report (Art. 21(3))*
- *before the expiration of the time limit for amending the claims and to be republished in the event of receipt of amendments (Rule 48.2(h))*

(88) Date of publication of the international search report:
29 December 2011

**A HIGH PRESSURE FEEDER AND METHOD OF OPERATION
TO FEED GRANULAR OR FINE MATERIALS**

[0001]

STATEMENT REGARDING FEDERALLY SPONSORED RESEARCH OR DEVELOPMENT

[0002] This invention was made with Government support under Cooperative Agreement Number DE-FC21-90MC25140 awarded by the United States Department of Energy. The United States government has certain rights in the invention.

FIELD OF INVENTION

[0003] This disclosure relates to a device and the method of operation to feed a mixed size of granular or fine materials to a high pressure vessel.

BACKGROUND

[0004] One difficulty in feeding granular or fine coal with moderate amounts of moisture into a high pressure gasifier includes devising a reliable way to increase the pressure of the coal stream from atmospheric pressure to the operating pressure while accurately metering the coal feed rate. Essentially, three methods have been practiced: slurry coal feed systems, dry powder feed systems with a lock vessel and rotating metering devices, and coal pumps.

[0005] For the slurry coal feeder, the slurry includes 32-40 wt% water added to the powder coal to make the coal slurry viscosity low enough for pumping into a high pressure gasifier. A

fundamental issue with this approach is that the cost of drying the low rank coals to a nearly moisture-free condition is very high because the drying process can be quite lengthy. For example, US Patent No. 6,162,265 discusses drying and preparing a slurry with low rank coals. The process is quite complicated and increases the capital, operating and maintenance costs to a level where the gasification facility becomes economically unattractive. It is relatively easy to remove the surface moisture from the coal; however, the drying facility required to remove nearly all the moisture including inherent moisture from coal is quite large. After removing nearly all the moisture from the coal, water is added again to make the slurry. In addition to the high cost of drying the coal, the thermal efficiency of the gasification process will be low because the water added to slurry the nearly dry coal needs to be evaporated in the gasifier. Thus, in the combined process of coal drying and slurry feeding, the moisture in and with the coal undergoes evaporation twice. The energy required to evaporate the water in the gasifier increases the oxygen consumption as well as the associated capital and operating costs. If the coal is not dried before slurrying, then the amount of water that needs to be evaporated in the gasifier nearly doubles as the low rank coals contain significantly high levels of moisture, which can be in the range 30 to 45 percent by weight of the coal. The double duty moisture evaporation in the gasifier significantly lowers process efficiency and useful syngas yield and increases operational costs with high oxygen consumption and higher cooling duties to condense moisture from the syngas. Therefore, using the slurry method to feed low rank coals to a high pressure gasifier is economically unfeasible. This may be the fundamental reason why no known commercial practice exists.

[0006] Using a lock vessel, as has been operated in the prior art, to feed the granular coal and metering the coal with a rotating device such as an auger or a screw feeder encounters problems too. The lock vessel is a means to increase the pressure as the coal moves from the atmospheric pressure in the storage bin to the operating pressure in the feed vessels. The lock vessel method to increase the pressure is based on swinging the pressure between the

atmospheric and operating pressures cyclically. The lock vessel has two valves: one connecting the atmospheric pressure storage bin from which coal is fed to the lock vessel and the other connecting to a coal feed vessel which receives coal from the lock vessel and is maintained at the operating pressure of the gasifier. In cyclic operation, when the lock vessel is ready to receive coal from the atmospheric vessel, the inlet valve opens. Once the coal reaches a predetermined level, the inlet valve closes. Then the lock vessel is pressurized using nitrogen or any other relatively inert gas such as CO₂. When the lock vessel pressure equals to the feed vessel pressure, the outlet valve opens. The coal in the lock vessel is supposed to flow into the feed vessel under gravity. And most times, it does. However, when the coal moisture increases to above 5%, finely ground coal particles tend to pack in the lock vessel when the lock vessel is pressurized. The packed coal in the lock vessel will not dislodge from the lock vessel into the pressurized feed vessel. The feed vessel will gradually empty out, eventually interrupting the coal feed to the gasifier. The loss of coal feed affects the gasifier operation because it has to be shut down and restarted, thereby increasing operational costs and causing a loss in production.

[0007] The metering devices are generally rotating devices that require an appropriate seal to prevent the coal fines from leaking to the atmosphere. It is difficult to develop a long lasting reliable seal mechanically for the high pressure differences that exist between the feeder and the atmosphere because of the presence of coal dust and constant rotation of the device. Further, the accuracy of the metering becomes difficult because of the changes in coal bulk density. Erosion of the rotating device and housing by the coal particles is a significant issue for certain types of coal feeders.

[0008] Using a coal pump to directly feed coal to a high pressure gasifier has been in development for many years; but, the device has not been developed sufficiently enough for commercial applications. The fundamental issue is the wide variance in the properties of the coal powder or granular material. As the pressure seals are designed for certain narrow range of coal particles, it is difficult to seal at high pressures all the time for naturally varying feed

characteristics of ground coal. The ground coal properties vary due to variations in raw coal, variations in crushing and milling operations and segregation of coal particles during storage and conveying. Any interruption of feed or blowback of hot ignitable process gases and gasifier bed materials can be highly unsafe for the coal pump system.

SUMMARY

[0009] The present disclosure describes an apparatus and methods of operation to feed granular or fine low rank coals with high moisture content, which can be as high as 25%, to a gasifier with operating pressure in the range of about 5 to 1000 psig.

[0010] The present disclosure relates to a solids feed system that provides an apparatus and method of operation to feed prepared coal or carbonaceous materials to a high pressure vessel. The preferred coal moisture is in the range of about 1-25%. The coal particle size can be in the range of about 0-6 mm. It should be appreciated that there are various ways to define irregularly shaped particles. Generally, some coal particles can have a sphericity around 0.7 – sphericity refers to diameter of an equivalent spherical volume. In the context of this disclosure, a 6 mm particle, for example, refers to particles that can pass through a 6 mm sieve screen. Normally, it is understood that this is the case (passing through a sieve screen) unless stated otherwise. Even though the feed system can handle many different solids, the system is described using coal as the solid particles to feed as coal is one of the most difficult materials to handle because of its heterogeneity and differing characteristics.

[0011] The processed coal is stored in a coal storage bin and is fed to the lock vessel whenever a cycle demand signal is received from the control system. The present disclosure provides two methods to ensure that the solids particles dislodge and fall out of the lock vessel and into the feed vessel as desired by the operational sequence.

[0012] The first method, according to the present disclosure, is termed as a micro-fluidization method. During operation of the lock vessel, the lock vessel may be pressurized

directly to the feed vessel pressure at a predetermined pressurization profile and rate before the lock vessel exit valve opens to the feed vessel. If the solid particles pack in the lock vessel, the operation fails as the feed vessel does not receive additional solids and the solids feeding process is interrupted. In one embodiment of the present disclosure, if the system operating pressure is greater than 50 psia, the lock vessel is pressurized to a pressure 3-10% higher than the system operating pressure. The pressure is then reduced to the feed vessel operating pressure by venting the gas out of the lock vessel to the coal surge bin. The gas venting rate or the orifice in the venting line is designed to ensure the gas superficial velocity in the lock vessel is about twice the minimum fluidization velocity of the mean particles in the lock vessel.

[0013] To ensure that substantially all the materials in the lock vessel are fluidized during the micro-fluidization process, gas venting elements are installed in large lock vessels. The structure of these venting elements includes steel pipes with many holes drilled through the pipe wall and all the holes are covered with gas permeable material that is impermeable to solids. One of these materials is sintered metals. Other materials and arrangements are equally feasible.

[0014] Further, to aid the fluidization process, additional gas can be added to the lock vessel through a gas distribution membrane or through gas addition pipes inserted into the lock vessel. The added gas will travel to the vent pipes and in the process to fluidize the bed materials.

[0015] For solid particles that do not have the strong tendency to pack throughout the lock vessel, the particles may still tend to pack mainly at the bottom of the lock vessel near the solids exit. The particle packing can be broken down by over-pressurizing or under-pressurizing the lock vessel to about 2-15 pounds per square inch (psi) higher or lower than the operating pressure of the feed vessel. When the valve between the lock and feed vessels is opened, the pressure difference will cause rapid gas exchanges between the lock and feed vessels. As a result, the bridge or particle packing near the lock vessel bottom will be broken down.

[0016] Another objective of the present disclosure is to have a pressure control device in the downcomer below the feed vessel to maintain a constant pressure difference between the gasifier or reactor vessel and the solids exit at the feeder. The device allows the system to rapidly inject or extract gas out of the feed system, maintaining a desired constant feed system pressure.

[0017] The feed system has a feed device downstream of the pressure control device. The feed device consists of a downcomer, a short riser and aeration nozzles. The solid particles in the lower part of the riser flow as a moving, expanded bed. The control gas from the feed vessel and feed device flowing into the downcomer and through the riser keeps the bed expanded. One of the objectives of this disclosure is to control the solid particles feed rate by controlling the bed moving speed in the riser with the total control gas that flows through the feed device.

[0018] Another objective of the disclosure is to reduce or prevent transport gas from contacting solid particles in the feed vessel and the downcomer. The transport gas is added to the top of the riser and conveying line to ensure sufficient conveying velocity is maintained. This facilitates the use of small amount of inert control gas in the feed vessel with large amount of reactive transport gas in the conveying line, preventing any reactions between the transport gas and solid particles in the feed vessel.

[0019] Another objective of the current disclosure is solids feed rate control through a combination of both control gas to the feed system and feed system pressure. For a given characteristic of the solids, the control of the feed rate is based on the gas flow rate to the discharge section of the feeder and the gas flow rate to the feed vessel. For the constant feed rate operation, the gas feed to the feed vessel is slightly higher than the solids volumetric flow rate out of the feed vessel. If the characteristics of the solids changes during operation, mass flow rate of coal or solids to the gasifier or reactor can be maintained by maintaining a constant feed system pressure.

BRIEF DESCRIPTION OF THE DRAWINGS

[0020] Aspects of the present disclosure can be better understood by illustrations and will be described by reference to the following drawings.

[0021] FIG. 1 is a schematic of a feeder assembly including a feed storage bin, a lock vessel, a feed vessel, a pressure control device and a feeder device in accordance with various embodiments of the present disclosure.

[0022] FIG 2 is a schematic of the pressure control device of FIG. 1 in accordance with various embodiments of the present disclosure.

[0023] FIG 3 is a schematic of the lock vessel of FIG. 1 with internal gas distribution and venting arrangements in accordance with various embodiments of the present disclosure.

[0024] FIG 4 is a schematic of a lock vessel gas injection and release device in accordance with various embodiments of the present disclosure.

[0025] FIG 5 is a schematic of the feeder device of FIG. 1 in accordance with various embodiments of the present disclosure.

[0026] FIG 6 is an experimental trend of lock and feed vessel pressures illustrating micro-fluidization.

[0027] FIG 7 is an experimental trend of coal feed rate versus total Control nitrogen flow rate through the PDAC feeder device.

DETAILED DESCRIPTION

[0028] As shown in FIG. 1, a pressure decoupled advanced coal feeder (PDAC) **100** according to one embodiment of the disclosure, comprises an assembly of vessels and feed and pressure control devices. It includes a coal surge bin **102**, configured to temporarily store processed coal in transit from a coal preparation system to a gasifier or reactor **150**. The coal surge bin **102** also accepts vent gas from a lock vessel **108**. A plurality of filter bags **101** are

installed in the surge bin **102** to filter out coal dust. Also, a screen **104** with an opening is installed to prevent failed bags that fall from interrupting the coal feeding process. In some embodiments, the openings of the screen **104** can be sized in the range of about two by about two inches. Also included are a feed vessel **114**, a pressure control device **117**, a coal feed rate control device **120** and a coal density measurement instrument **130** on the coal conveying line **132** that conveys coal to the gasifier or reactor **150**.

[0029] At least one valve **106** is installed between the lock vessel **108** and the surge bin **102**. In many embodiments, two valves can be employed between the lock vessel **108** and surge bin **102**. The first valve below the surge bin **102** isolates the surge bin from the lock vessel **108** when the feeder system goes through an outage. The second valve can be located between the lock vessel **108** and the first valve below the surge bin **102** and acts as a pressure boundary between the lock vessel and the surge bin. The second valve closes in a relatively clean environment as it is timed to close at least a few seconds after the first valve closes.

[0030] The valve **106** can open on demand and coal from the surge bin **102** fills the lock vessel **108** to a desired level. An initiation signal for adding coal to the lock vessel **108** can be a sequential action signal. The initiation signal can be based at least upon a coal level measurement in the coal feed vessel **114**. For illustration purposes, one can use a level probe **115** as a starting point for the cycle of coal transfer. When the level probe **115** has detected that the coal level has reached a preset level, a sequence starts with the opening of the lock vessel inlet valve **106** to fill the lock vessel **108** to a pre-determined level **107**. The level measurement for the lock vessel **108** can be any of the various level measurement techniques, such as gamma ray measurement, a conductance level probe, a capacitance level probe, a vibratory probe, ultrasonic level measurement, and other level measurement techniques. Once the level measurement has detected the solids level, the lock vessel solids inlet valve **106** is closed and the lock vessel **108** starts the pressurization process. In prior art processes, the lock vessel **108** is pressurized to a pressure equal to the feed vessel pressure and the valve **110** on

the balance line **111** will open. At substantially the same time, the valve **112** at the outlet of the lock vessel **108** can open. The solids can flow out the lock vessel **108** by gravity into the feed vessel **114**. However, when the solids such as coal in the lock vessel **108** contain a substantial amount of particles less than, for example, 45 microns in size, as well as particles having a relatively high moisture content, the particles may tend to pack and cannot flow freely under gravity. Solid particles such as coal, when dried and pulverized, may not be uniform in size and moisture characteristics may change over a period of time as short as a day. When size and moisture characteristics are out of bounds even for short duration during the day, it can lead to loss of coal feed to pressurized units such as a gasifier or reactor **150**. By one of the following three methods, embodiments of the disclosure can maintain feed even if characteristics of feed particles vary.

[0031] In one embodiment, the lock vessel **108** can be over-pressurized about 3-15 psi higher than the pressure in the feed vessel. In different lock vessel operational methods described herein, the pressurization sequence includes a slow pressurization rate (e.g., for up to about 60 seconds), followed by a fast pressurization rate until the pressure is within 5% of the desired final pressure, and finally a slow pressurization rate until the desired final pressure is reached. The timing of each pressurization step can change depending on the characteristics of the coal source. Packing of the particles may occur at the start of pressurization and the initial slow pressurization step is helpful to minimize the effects of packing. The final slow pressurization step can ensure that the desired pressure is reached with minimum overshoot.

[0032] When the higher preset pressure of the lock vessel **108** has been reached, the valve **110** on balance line **111** can open first because the pressure is higher in the lock vessel **108** than in the feed vessel **114**, and gas will flow from the lock vessel **108** to the feed vessel **114**. The gas release from the lock vessel **108** may have a tendency to fluidize the solids in the lock vessel or break any minor bridging in the lock vessel **108**. After a short time delay (e.g., between about 500 milliseconds to about 1 second), the lock vessel exit valve **112** can be

opened. As the lock vessel **108** is still slightly under positive pressure, the minor bridging of the solids in the lock vessel exit can break and fall under gravity as well as with a push from the positive pressure in the lock vessel **108**. By minor bridging, it is understood that the solids will normally flow and occasionally, (e.g., about every four to eight hours or about 30-60 cycles), there occurs a weak lock vessel bridging at the exit during which the solids fail to fall into the feed vessel **114**. Whenever such a bridging occurs, the above procedure will break the bridge and the feed process will continue. This operation method is termed as an over-pressurization mode.

[0033] To maintain the pressure difference between the PDAC feeder device exit **123** and the reactor **150** substantially constant, the additional gas from over-pressurization that causes the higher pressure in the feed vessel **114** and coal feeder exit must be properly released. In one embodiment, in the present disclosure, the gas release is accomplished by a pressure control device. US Patent Publication No. 2010/0263342, which is incorporated herein by reference, describes a pressure control device (known therein as a pressure let-down device) and operating such a device in a different application where the device facilitates let-down of the solid streams pressure from an operating system pressure to substantially atmospheric pressure.

[0034] In the embodiment, a pressure control device **117** is presented in FIG 2 for coal feeder application, where the pressure control device is reconfigured for use as a means to add gas through valve **119** to the solids stream **214**. The gas chamber **206** is isolated from the process solids stream **214** with a bed of inert granular solids **210** held in place with an inner gas permeable membrane **212** and an outer gas permeable membrane **208**. Gas can also be extracted through valve **118** to reduce solids stream **214** pressure. Unlike the device used in US2010/0263342, where the exit pressure of the solid stream is generally less than half of inlet pressure, in this embodiment the pressure difference across the pressure control device **117** is low, as the purpose is to control pressure by adding or venting gas in small amounts. With

addition/extraction of gas from solids stream **214**, the pressure of the solids stream at the exit **220** of the pressure control device **117** can be maintained substantially constant.

[0035] As the lock vessel **108** is operated in the over-pressurization mode, when the valve **110** in the pressure balance line **111** and the valve **112** are open, the gas together with the solids can travel out of the feed vessel **114** faster due to a higher pressure difference created due to over-pressurization. If the gas and solids are allowed to flow from the feed vessel **114** to the reactor **150**, the pressure difference between the PDAC feeder device exit **123** and the reactor **150** may increase and as a result, the solids feed rate will also increase. As shown below, control of the pressure difference is critical to control the flow rate of the solids from the PDAC feeder device exit **123** to the reactor **150**. To avoid such a pressure increase, the excess gas due to over-pressurization of the lock vessel **108** can be released by the pressure control device **117** by opening the gas release valve **118**.

[0036] The pressure control device **117** as shown in FIG 2 can be located in the downcomer, downstream of the feed vessel **114**, and receives gas and solids flow stream **214** from the lock vessel **108**. The connecting pipe **203** and the pressure control device **117** are in communication with the feeder vessel **114** at a first end and the PDAC feeder device **120** at an opposing end. When a pressure measurement device **127** detects a pressure that is higher than the preset value, the control valve **118** will open to rapidly reduce, if necessary, the feed vessel **114** pressure to the preset value. The gas and solids stream at the exit **220** of the pressure control device **117** is nearly at constant pressure. Note that a brief high coal feed rate spike is nearly harmless for the coal gasifier's performance and operation. Therefore, for the over-pressurization mode, the gas releases to reduce the feed vessel pressure need not be drastic and can be easily controlled. Operating the lock vessel **108** and the system under the over-pressurization mode can be advantageous because the logic of the system reduces any possibility of the gas reverse flow from the reactor **150** to the feeder which, if it occurs, is a safety concern. Under the over-pressurization mode, the worst scenario is a spike in the coal

feed rate due to any potential inaccuracy in pressure control. Normally, the pressure control can function reliably and precisely and the coal feed rate will not show any spikes.

[0037] A second operation mode for the lock vessel is termed under-pressurization mode. This mode can function when the packing that occurs in the lock vessel is due to the fines fraction in the coal that is higher than normal. Under this operating mode, the lock vessel **108** is pressurized to a slightly lower pressure than in the feed vessel **114**. Depending on the characteristics of the coal, the pressure differential can be in the range 3 to 15 psi. When the pressure in the lock vessel **108** reaches the preset pressure, which can be about 3 to 15 psi below the feed vessel pressure, the valve **112** can be configured to open. The higher pressure in the feed vessel **114** will force the gas from the feed vessel to flow upward into the lock vessel **108**. After valve **112** opens, the valve **110** in the balance line can also be configured to open after a short delay. As the coal starts to fall from lock to feed vessel, the space occupied by coal should be filled by a gas. As the coal falls into the feed vessel, an equivalent amount of gas is displaced. The gas displaced from the feed vessel can go through the balance line to lock vessel to occupy the volume of coal that moved to feed vessel.

[0038] In the under-pressurization mode, even a small pressure difference can cause the gas from the feed vessel **114** to rush to the lock vessel **108** at high velocities. This exerts sufficient force from bottom and breaks any bridge that typically forms at the lock vessel exit. The rushing velocity can be as high as 120 ft/s even at a low 2 psi pressure difference at 250 psig operating pressure. Also, a part of the additional gas injected will also rush into the lock vessel **108**, fluidizing the materials in the lock vessel **108** and minimizing the effect of packing.

[0039] The under-pressurization can cause a substantially instantaneous pressure reduction in the feeder system which, in turn, can cause a feed rate reduction if no further action is taken. But, a reverse flow situation is unlikely because the normal operating feeder pressure is designed to be at least 15 psi higher than the reactor pressure. In practice, the pressure differential during normal operation can be 50 psi. However, feed rate reduction from the feed

system in supplying coal to the gasifier is undesirable. To avoid the feed rate reduction, gas is injected into the feeder system through the feed line **122** to upper (stream **126**) and lower (stream **129**) portions of the feed vessel **114**, the pressure control device **117** using valve **119** and the PDAC feed device **120** with stream **124**. The distribution of the gas between these streams is dependent on the characteristics of feed material and system design. It is understood that the number of nozzles in the feed vessel **114** and PDAC feed device **120** can be multiple. The amount of additional gas necessary for a given lock vessel size and the extent of under-pressurization can be calculated quite precisely. For example, if the lock vessel volume is 500 ft³ with 50% of the volume occupied by the gas phase and the lock vessel **108** is 15 psi under pressurized, then the total amount of additional gas necessary is 17.5 lbs. With a known amount of additional gas needed and the desired time interval to restore the pressure in the feed vessel, people skilled in the art can size a buffer tank or select appropriate line sizes and control valves to inject the gas. To minimize the time lag and considering the actuation time for the valves, a feed forward control system can be used and a signal issued to the gas injection valves to ensure the pressure restoration time is less than about 500 milliseconds.

[0040] Another embodiment of the disclosure is termed micro-fluidization. The lock vessel **108** can be pressurized about 3-15% higher than the pressure in the feed vessel **114**. The high pressure gas is then released from the lock vessel **108** through valve **134** in vent line **128** until the pressure in the lock vessel **108** is essentially the same as the feed vessel **114**. If gas is released uniformly throughout the solids bed in the lock vessel **108** and the gas superficial velocity in the lock vessel **108** is substantially higher than the minimum fluidization velocity of the particles, then the solids bed in the lock vessel **108** will be fluidized. This minimizes the effects of particle packing in the lock vessel **108** and the solids will free fall into the feed vessel **114** when the valve **112** shown in FIG 1 opens.

[0041] For most solids, the particle packing effects in the lock vessel **108** are reduced during later stages of the fast pressurization step. A variation of micro-fluidization can be

effected by venting gas in the time range of about 1 to 3 seconds during the fast pressurization step and then continuing to pressurize to feed vessel pressure before opening the balance line valve **110** and the valve **112** between the lock vessel **108** and feed vessel **114**. This variation is helpful as much of the particle packing occurring during the initial pressurization stage can be dislodged and solids aerated. Solids have fewer tendencies to pack with continued pressurization after the micro-fluidization step.

[0042] One aspect of micro-fluidization includes releasing the high pressure gas from the lock vessel **108** as uniformly as possible. The method can be best illustrated with the lock vessel **108** depicted in FIG 3. To release gas substantially uniformly throughout the lock vessel **108**, gas release elements can be installed inside the lock vessel **108**. The gas release elements **310** and **320** are similar in structure and are further illustrated in FIG 4. The gas release elements **310** and **320** comprise a ring header **410** for collection as well as for distribution of the pressurizing gas as necessary. A plurality of gas permeable pipes **412** are mounted onto the ring header **410**; the length of the pipes **412** can vary depending upon the shape of the lock vessel **108**.

[0043] FIG 4 illustrates the structure of the gas permeable pipe **412**. The inner part **452** is a pipe with a plurality of holes drilled through its wall. The size of each hole can vary, but in one embodiment, they can be sized from about ¼ inch to about ½ inch. The number of holes depends at least upon the pipe size and the amount of gas to be released. One guideline is that the total cross-sectional area of the holes can be at least 10 times the cross-sectional area of the pipe **412** based on the pipe diameter so that the holes will not provide any substantial resistance to the gas flow. The outer member **454** of the gas permeable pipe **412** can be made of any gas permeable material. However, as discussed below, the pipe **412** can be used for gas to flow both ways. Therefore, in one embodiment, the pipe **412** can be rigid. The most common material that fits this application is sintered metals which are available in various pore

sizes. The sintered metal can restrict particles from entering the inner pipe and erode the venting valves.

[0044] When the lock vessel **108** operates in a micro-fluidization mode, the gas release pipe **412** can also be used during pressurization to distribute the pressurizing gas **302** for materials that have low permeabilities. When these internals are used for the gas distribution, they can distribute the gas quicker and more uniformly throughout the solids bed overcoming flow restrictions due to low permeabilities. The uniform distribution of the gas throughout the solids bed in the lock vessel **108** is a challenge for those solid particles with poor permeability. Some practitioners promote a slow pressurization technique so that the gas can penetrate throughout the bed during the pressurization stage. However, often times for commercial operation, this technique becomes impractical as it requires long pressurization times. The internal arrangement embodiments of the lock vessel **108** presented in FIGS 3-5 render a much shorter gas flow path in the bed compared to the use of a conical membrane and/or nozzles on a side of the lock vessel **108** as the pressurization means. During the pressurization stage, a hyperbolic membrane **330** located in the cone section of the lock vessel **108** (as illustrated in FIG 3) can also be used to add gas **302**.

[0045] In one embodiment, one guideline for micro-fluidization is that the pressure in the lock vessel **108** should be about 3-15% higher than the feed vessel pressure depending on the operating pressure, the size of the lock vessel **108** and characteristics of the feed material. The percent of over-pressurization in the lock vessel **108** is lower with the increased operating pressure and with the increased size of the lock vessel **108**. After the lock vessel **108** has reached the preset over-pressure for micro-fluidization, the pressure release rate through the internal gas release elements **310** and **320** as well as the normal venting line **128** can be such that the gas velocity in the lock vessel **108** is larger than two times the minimum fluidization velocity to facilitate fluidization of substantially all materials in the lock vessel **108**, reducing the effect of the particle packing. In one non-limiting example, if the feed vessel is pressurized at

about 500 psi and a 10% over pressure is chosen before the vent valves are open, then the 'preset' overpressure is 550 (500+10% of 500) psi.

[0046] To ensure the coal in the lock vessel **108** is fluidized during the gas release stage for materials prone to packing, gas stream **302** (as indicated by FIG 3) can be injected for a few seconds through the membrane **330** in the cone section of the lock vessel **108**. Since the cone and exit sections of the lock vessel **108** are most likely to be packed, the gas injection during the gas release can aid the solids to be fluidized in these sections and thus reduce the effects of particle packing and bridging that may occur during pressurization. After the over-pressurized gas is released and the lock vessel pressure equals the feed vessel pressure, the solids can freely fall into the feed vessel **114**. The gas release operation during micro-fluidization can, in one embodiment, last between about 1 to about 5 seconds depending upon the operating pressure.

[0047] As has been mentioned above, the pressure control device **117** can be used to control the pressure difference between the feeder and the reactor **150** either by withdrawing the gas or by adding the gas to the solids stream **214** flowing through the device **117**. The second method used to maintain the pressure difference between the coal feeder and the gasifier or reactor **150** is the PDAC feeder device **120** as shown in FIG. 5. The control gas added through the feed vessel **114** and pressure control device **117** flows through the PDAC feeder device **120**. Additional control gas **124** is added as necessary to control the coal feed rate through the device **120**.

[0048] The coal feed rate is controlled through a combination of both control gas to the feed system that passes through the PDAC feeder device **120** and feed system pressure. For a given characteristic of the solids, the control of the feed rate is based at least upon the gas flow rate to the discharge section of the feeder and the gas flow rate to the feed vessel and the pressure control device **117**. For the constant feed rate operation, the gas feed to the feed vessel **114** is slightly higher than the solids volumetric flow rate out of the feed vessel **114**. A

part of the gas entering the feed vessel **114** occupies the volume displaced as solids are continuously fed out of the vessel **114**. If the characteristics of the solids changes during operation due to changes in grind or segregation in surge bin **102**, the mass flow rate of coal or solids to the gasifier or reactor **150** can be maintained by maintaining a substantially constant feed system pressure.

[0049] As shown in FIG 5, the coal from the pressure control device **117** moves down a short inclined downcomer section of the pipe **140**. The coal then moves through a short vertical riser **141** before being discharged to the conveying line through feeder exit **123**. A part of the conveying gas **125** enters the top of the riser through pipe **142** and exits into the riser **141** through an inverted cone **144** coupled to the end of pipe **142**. The conveying gas as it leaves the inverted cone **144** picks-up coal particles from the top of the moving expanded bed to convey the coal to the downstream unit. Both the control gas and conveying gas can flow upward through section **143**. Depending upon the characteristics of feed material and downstream process, the superficial gas velocity in section **143** of the riser **141** can be maintained between about 3 and 10 ft/s by adjusting the conveying gas flow rate. Additional conveying gas is added downstream of the feeder device exit **123** to maintain a superficial gas velocity in the line to convey coal to the gasifier or reactor **150**. Even though one configuration of feed rate control device **117** is shown in FIG. 5, a person skilled in the art of handling solids should appreciate other configurations involving changes to the way conveying gas is introduced into the riser and the way the coal is conveyed out of the riser that are consistent with this disclosure.

[0050] The size of the inclined leg in downcomer section **140** and riser **141** are chosen to achieve turndown and control over coal feed rate. The inclined leg is aerated by a small portion of the control gas and the coal flows through the inclined leg essentially by gravity. The diameter of the inclined leg is chosen to provide more than the maximum coal feed rate that the device is designed for in order to ensure that the feed to the riser bottom is not limited at the

maximum coal feed rate through the riser. Much of the control gas added to various locations in the feed system can enter the riser **141**. The characteristics of gas and solids in the riser **141** can be described as a moving dense expanded bed. The coal feed rate is proportional to the superficial gas velocity or the volumetric gas flow rate due to the control gas that eventually flows through the riser **141**. The superficial gas velocity in this portion of the riser can be between about 0 and about 1 ft/s. The control gas can range between about 10 to 15% of the total conveying gas.

[0051] The conveying gas **125** may be different from the control gas **124** added to various locations in the PDAC feed system. Due to reactivity concerns, there may be situations where it is not desirable to have conveying gas enter the feed vessel **114**, which can contain bulk amounts of the feed material. In air blown gasification, the conveying gas is air and the control gas is typically an inert gas such as nitrogen or carbon dioxide. The PDAC feed device embodiment shown in FIG 5 effectively prevents air from entering the feed vessel **114** and reacting with coal.

[0052] The apparatus and methods presented increases the feed system's reliability to maintain coal feed rate to the gasifier even with difficult to handle coals as well as with varying coal characteristics and preparation methods. The system's reliability is further increased as the feed device embodiment in FIG 5 has no moving parts, which are norm in other types of coal feeders. Rotary table feeders, auger feeders, piston feeders and rotating dry pump feeders are examples of other types of coal feeders that have moving parts that can be prone to wear and tear and other maintenance problems such as motors, shaft seal leakage, maintaining small clearances (e.g., 5 mil) between stationary and rotating parts, blow through and erosion issues.

EXAMPLE

[0053] Described below is one non-limiting example of an embodiment of the disclosure. None of the descriptions, ranges, or other information in this example should be considered to

limit the scope of the present disclosure. In a fast circulating, pressurized fluidized bed gasification pilot test facility, an auger and rotary table feeder systems were tested and poor availability of these systems and other inherent scalability issues led to the development of the PDAC feeder system. The PDAC feeder system can be directly lined-up to the gasifier for on-line gasification operation or can be connected to a closed-circuit Off-line Coal Feed Test System. The Off-line system, which included a large receiver pressure vessel simulating the gasifier and a pressure let-down system, allowed us to operate substantially continuously in closed-loop and test various concepts rigorously. When on-line to the gasifier, the feeder system can feed from about 300 to 6000 lbs per hour of coal at about 100 to 280 psig pressure; while in off-line test loop, the feeder system can feed similar rates up to about 480 psig pressure. For test purposes, the mass mean diameter of the coal was varied from about 200 to 800 microns. Low rank coals were predominantly tested and the moisture content of the feed coal varied from about 18 to 25 wt%.

[0054] During pressurization, tendency for coal particles to pack causes coal bridging in the lock vessel, which may negatively affect feed system performance and availability. In pilot test facility, originally, the traditional pressurization mode (equal-pressurization) was used for operation and that led to a number of outages. Lock vessel at the pilot test facility has been designed and operated in various modes described earlier: slow pressurization, under-pressurization, over-pressurization and micro-fluidization. Variety of operation modes were designed either to minimize bridging and packing potential or to break the bridging and packing once detected without losing feed to the gasifier.

[0055] As the lock vessel at the pilot test facility was small, no internals as described earlier was necessary and the micro-fluidization was practiced during pressurization before the pressure reached the feed vessel pressure (FIG 6). Also, for test purposes, in the over-pressurization mode, the valve between the lock and feed vessels was opened first and after a short time delay (1 to 5 seconds), the valve on the balance line was opened. As the internal

surface of the lock vessel had a smooth finish, reducing the wall friction, the intentional pressure difference for a short duration after opening the valve between the lock and feed vessel was helpful at times in assisting the solids to move to the feed vessel. A form of internal pipes with gas manifold discussed in reference to FIG 4 was tested. These pipes were located near the wall of the vessel and the ½ inch holes on one side of the pipe with sintered metal covering were facing the wall. After opening the valve between the lock and feed vessels, nitrogen was pulsed through the manifold and pipes to dislodge moderate packing on the side of the vessel. After experimenting with various means invented, the lock vessel operated trouble-free with a number of different coals, coal characteristics, grind sizes and moisture content.

[0056] At the test facility, the pressure control device is coupled with the PDAC feeder device to control and regulate the coal feed rate. During operation transitions such as start-up, ramp-up, ramp-down and gasifier trips, the pressure control device aeration or vent were used to quickly stabilize the PDAC system and the feed rate to new conditions. In normal operation, control (gas) nitrogen flow was used to control the coal feed rate. As shown in FIG 7, the PDAC feed system was designed to maintain proportionality between coal feed rate and control nitrogen flow rate in the desired operations range. The test facility also had a Trim control nitrogen flow to feeder device to slightly vary coal feed rate to address fluctuations inherent in the gasifier. Both the pressure control device and the PDAC feeder device were maintenance-free and 100% available in over 3,500 hours of testing.

What is claimed is:

1. A coal feeder system (100), comprising:
 - a coal surge bin (102) configured to store processed coal for feeding into a gasifier (150);
 - a lock vessel (108) coupled to the coal surge bin (102), the lock vessel (108) being a pressure swing device;
 - characterised by:
 - a gas collector and distributor disposed (310, 320) within the lock vessel, the gas collector and distributor configured to distribute gas within the lock vessel;
 - a gas permeable membrane (208, 212) disposed within a conical section of the lock vessel (108);
 - a feed vessel (114) coupled to the lock vessel (108), the feed vessel (114) configured to operate at a substantially constant pressure;
 - a pressure control device (117) configured to maintain a substantially constant pressure between the feed vessel (114) and a gasifier (150); and
 - a feeder device (120) configured to control a coal feed rate into the gasifier (150).
2. The coal feeder system (100) of claim 1, wherein the coal surge bin (102) is configured for temporary storage of processed coal, the processed coal comprising up to about twenty-five percent moisture by weight.
3. The coal feeder system (100) of claim 1, wherein the lock vessel (108) further comprises internals configured to release an entrained gas substantially uniformly throughout the lock vessel (108) and fluidize bed materials in the lock vessel (108), and the internals comprise a network of gas permeable pipes (412) comprising sintered metals and connected to a manifold, and wherein gas collected in the manifold is vented to the surge bin (102).
4. The coal feeder system (100) of claim 1, wherein the pressure control device (117) further comprises means to add or extract gas from a solids stream passing through the coal feeder system (100) to maintain a substantially constant downstream pressure.

5. The coal feeder system (100) of claim 1, wherein a bridged material in at least one of the conical section and an exit section of the lock vessel and a packed material adjacent to the walls of the lock vessel are dispersed, allowing pulverized material to flow from the lock vessel to feed vessel.

6. The coal feeder system of claim 1, wherein the feeder device is arranged to control the rate of coal feed to the gasifier (150) by maintaining a feeder pressure with gas injection at different locations and by measured flow of control gas through the coal feeder system (100).

7. The coal feeder system (100) of claim 1, wherein the feeder device (120) further comprises a vertical downcomer (140) and a riser (141), the downcomer being inclined with respect to the riser, a feed rate capacity of the downcomer being greater than a desired maximum coal feed rate.

8. The coal feeder system (100) of claim 7, wherein a lower portion of the riser is a moving expanded bed in proportion with an amount of control gas passing therethrough, a superficial gas velocity in the lower portion of the riser is in the range of zero to one foot per second.

9. The coal feeder system (100) of claim 7, further comprising an inverted cone configured to convey gas into the riser without substantially disturbing the moving expanded bed.

10. A method of using a coal feeder system (100) comprising a coal surge bin (102) configured to store processed coal for feeding into a gasifier (150); a lock vessel (108) coupled to the coal surge bin (102), the lock vessel (108) being a pressure swing device; a gas collector and distributor disposed within the lock vessel (108), the gas collector and distributor configured to distribute gas within the lock vessel; a gas permeable membrane (208) disposed within a conical section of the lock vessel (108); a feed vessel (114) coupled to the lock vessel (108), the feed vessel (114) configured to operate at a substantially constant pressure; a pressure control device (117) configured to

maintain a substantially constant pressure between the feed vessel (114) and a gasifier (150); and a feeder device (120) configured to control a coal feed rate into the gasifier (150), the method comprising the steps of:

loading the lock vessel (108) with pulverized coal;

pressurizing the lock vessel (108) by a slow pressurization step for up to about sixty seconds;

pressurizing the lock vessel (108) by a fast pressurization step until the pressure is within 5% of a final desired pressure; and

pressurizing the lock vessel (108) by a slow pressurization step until a final desired pressure is reached.

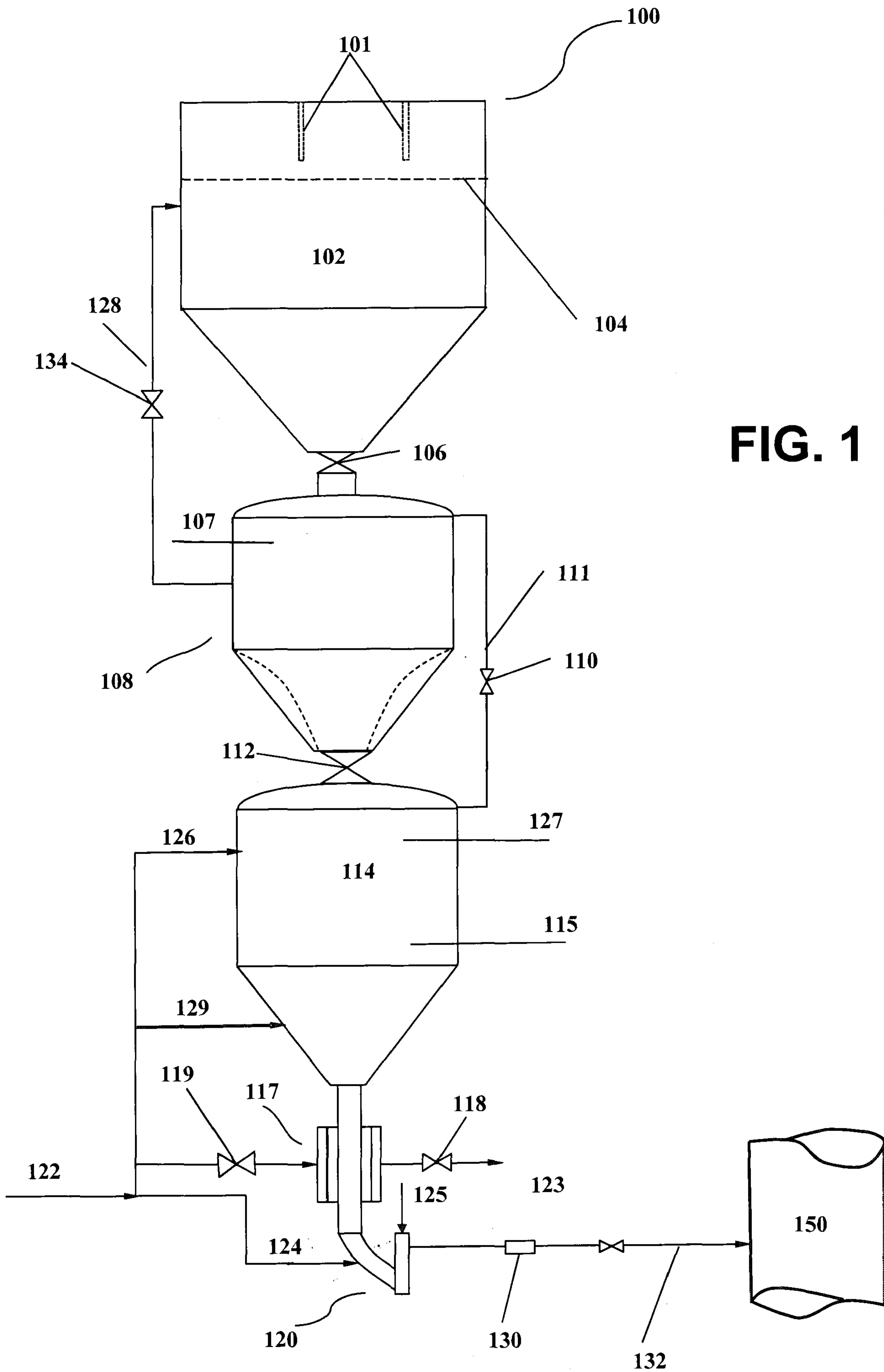

FIG. 1

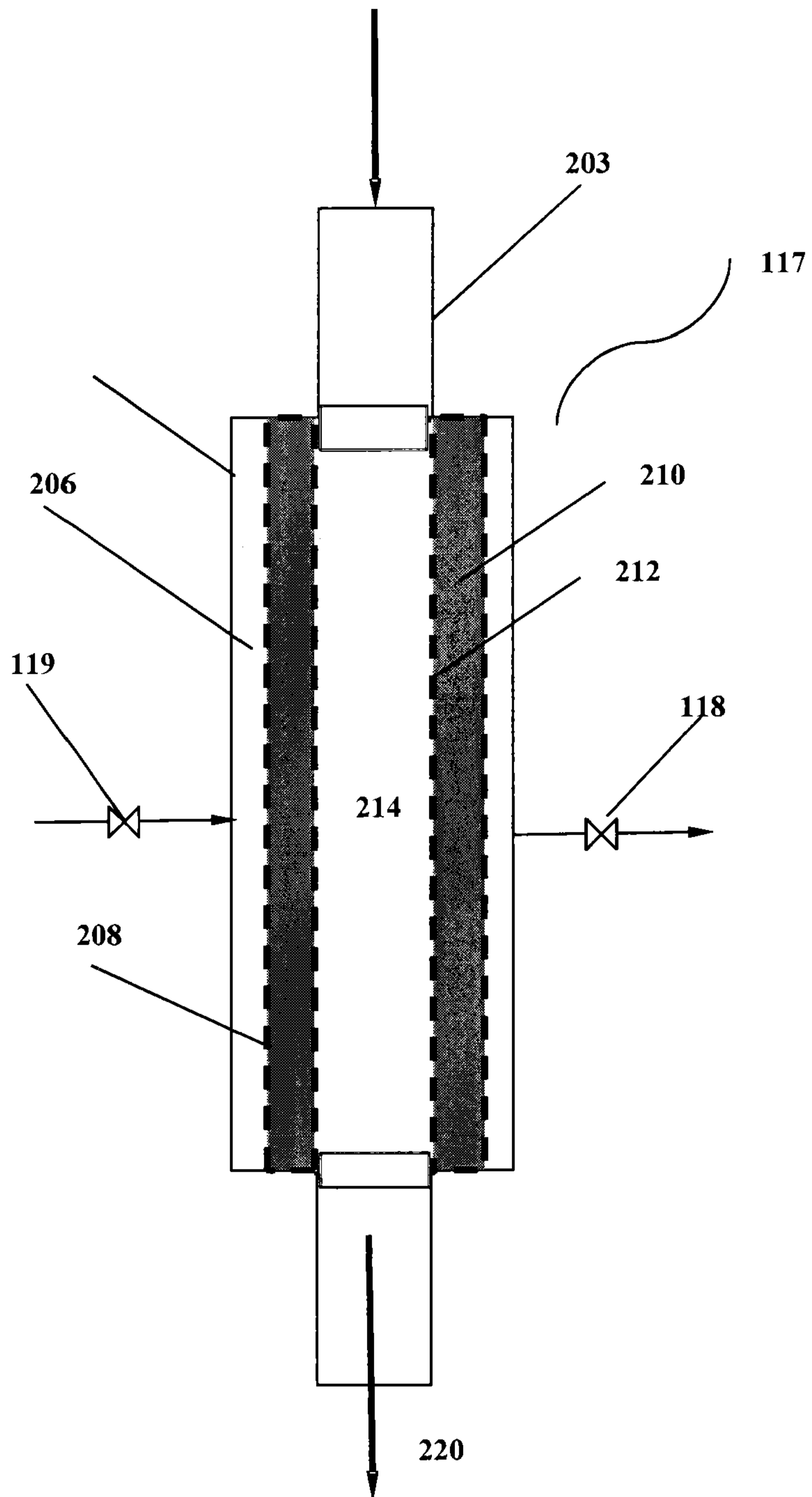

FIG. 2

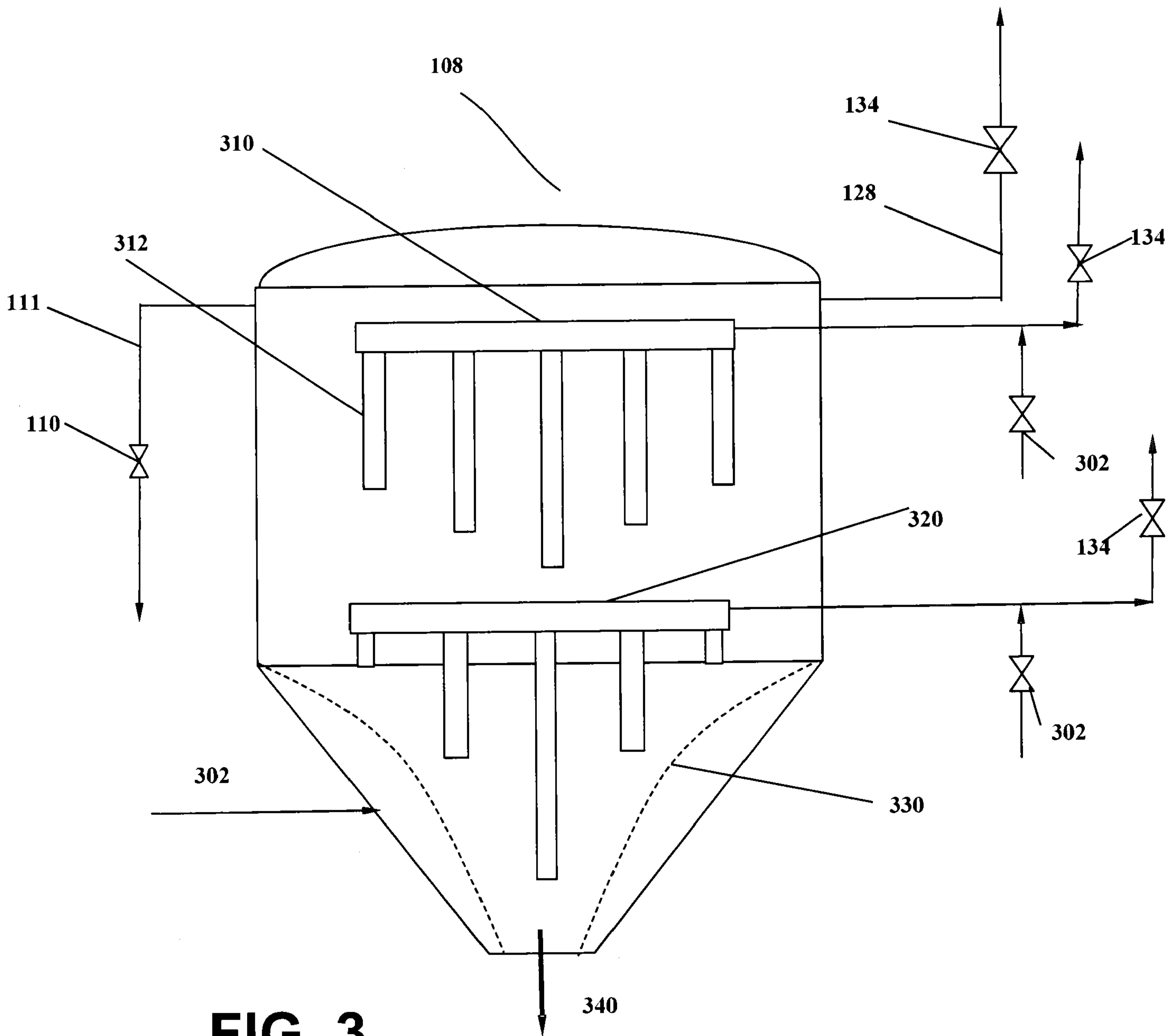

FIG. 3

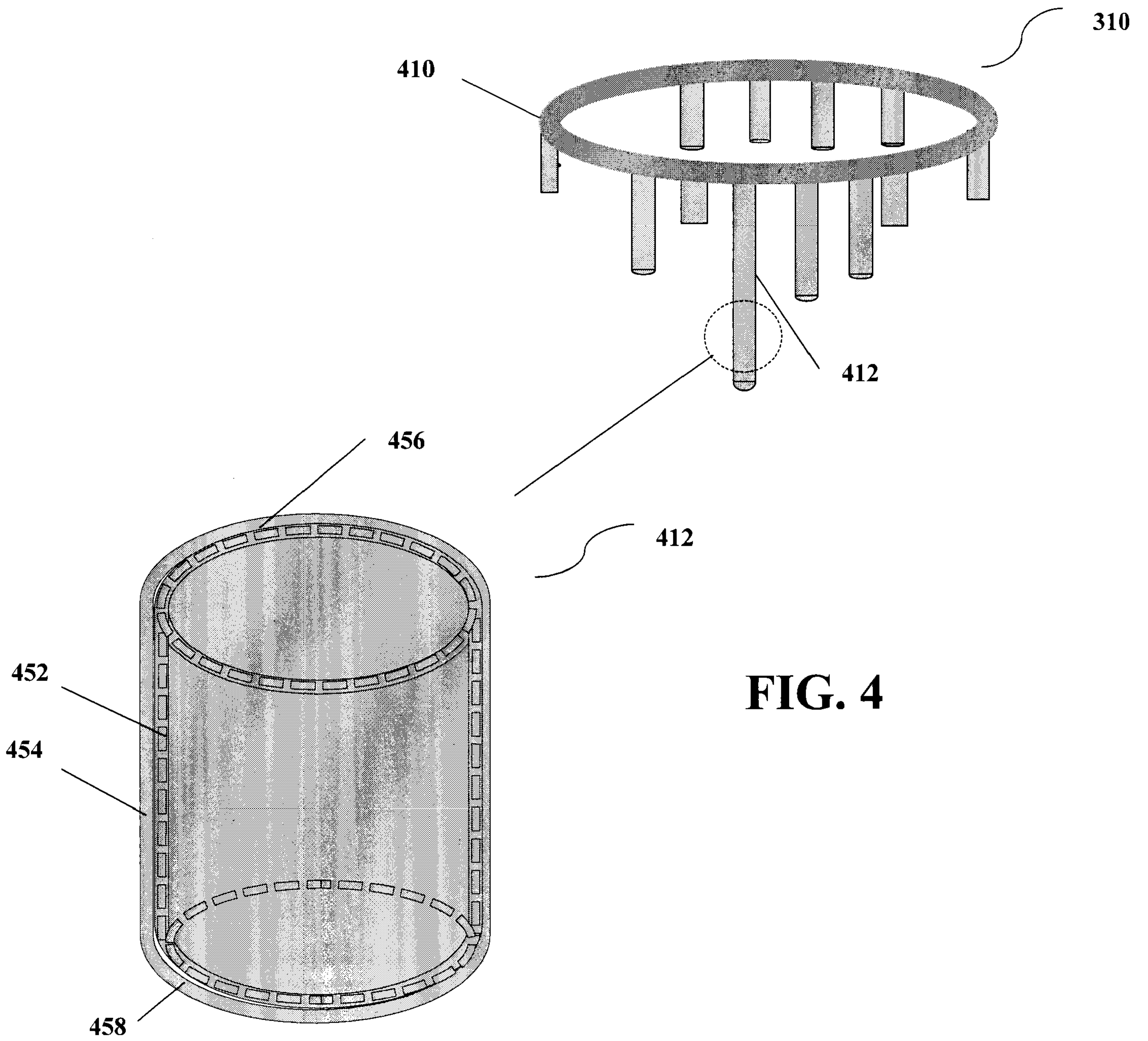
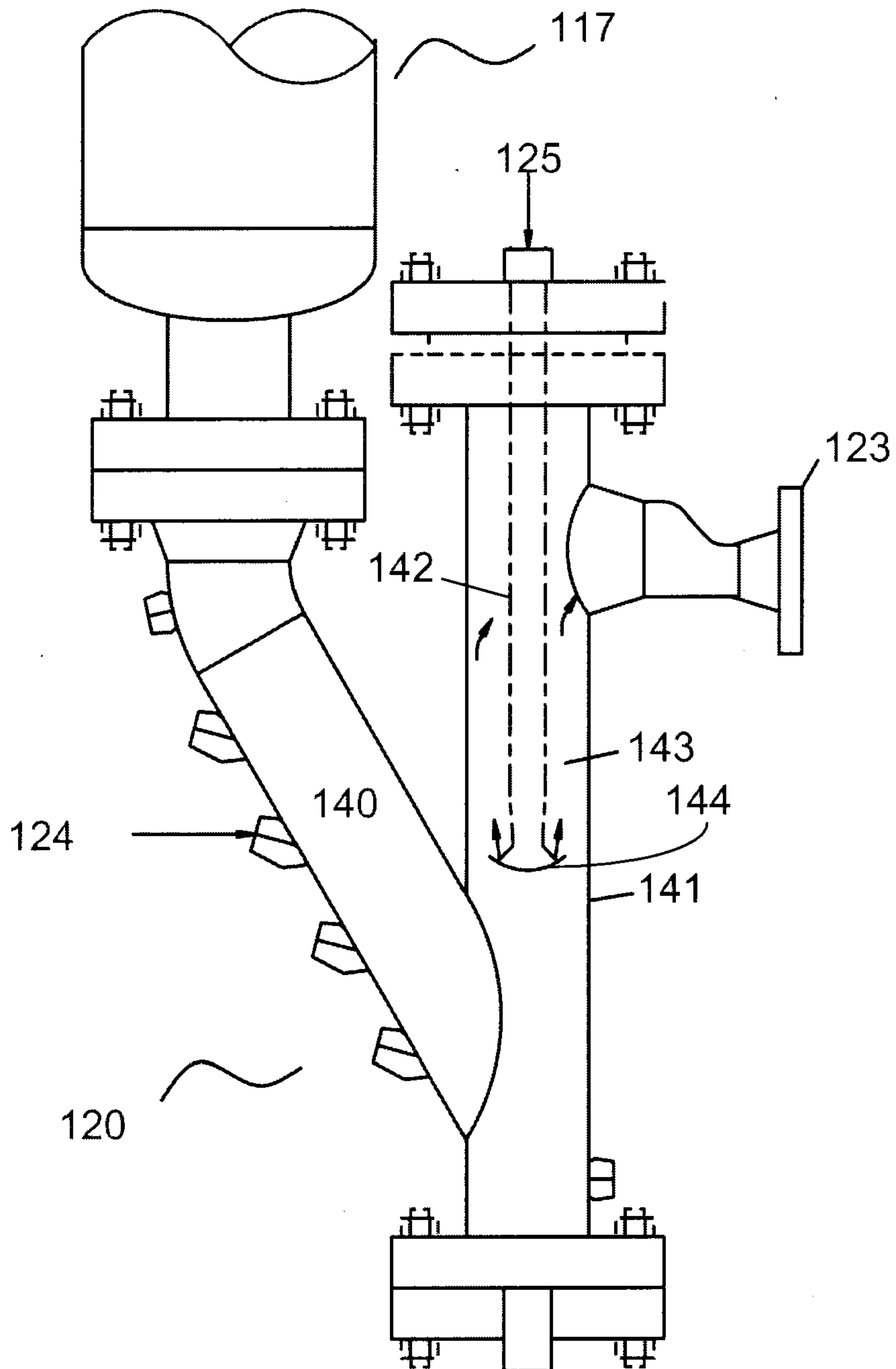

FIG. 4

**FIG. 5**

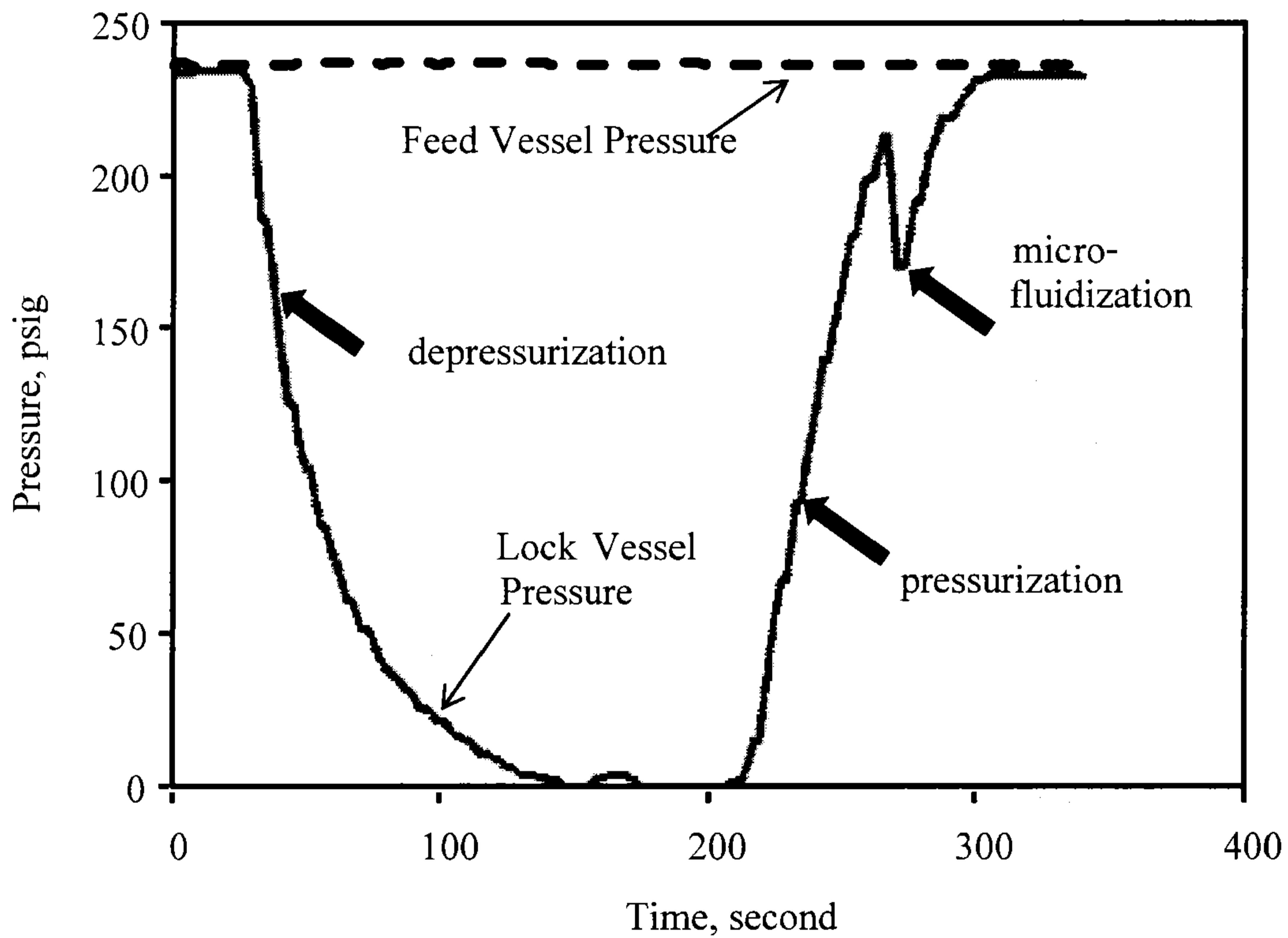

FIG. 6

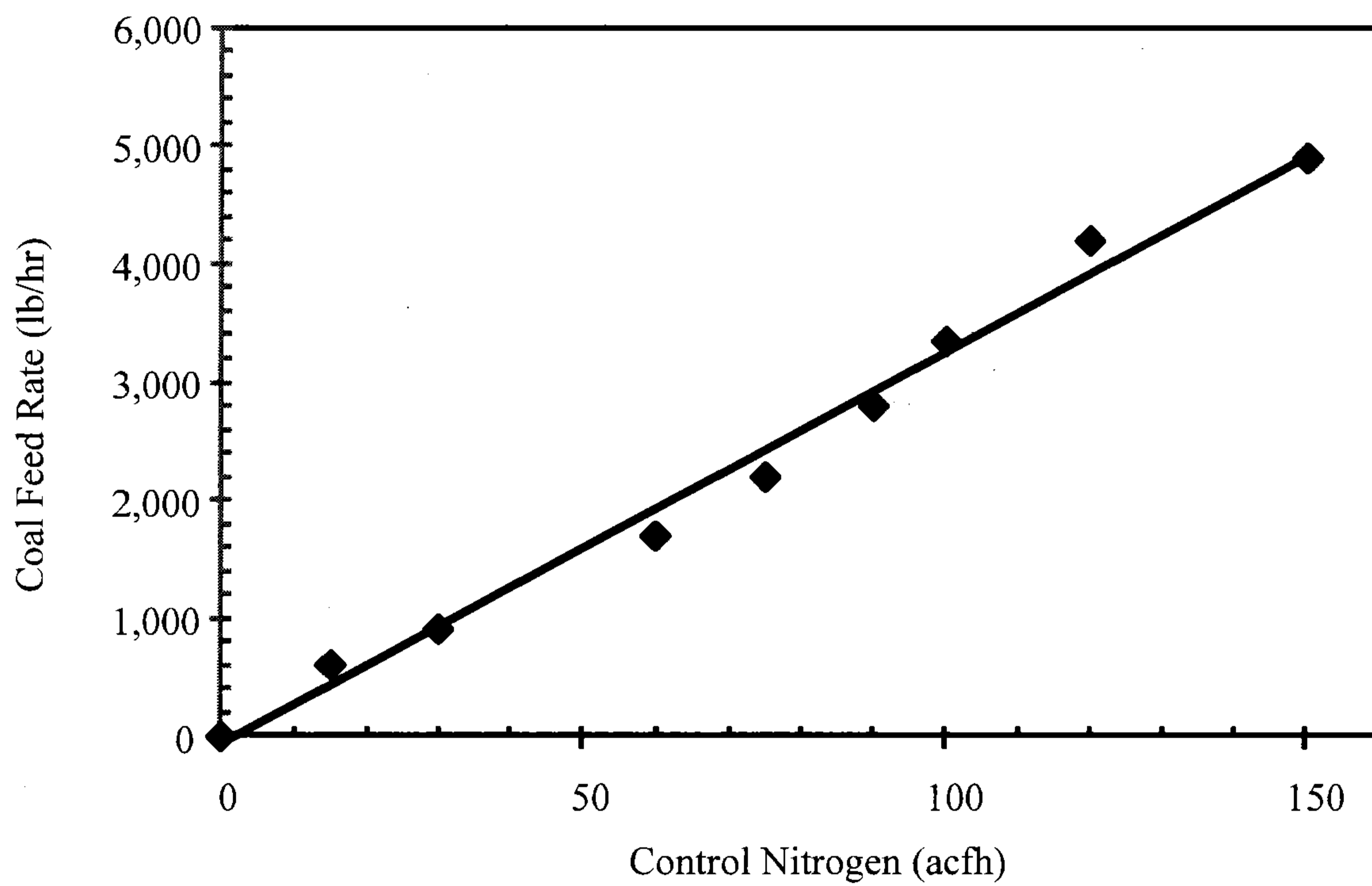

FIG. 7

