

J. MILEY.

REVERSING MECHANISM FOR MACHINE TOOLS.

APPLICATION FILED DEC. 20, 1905.

3 SHEETS—SHEET 1.

Fig. 1.

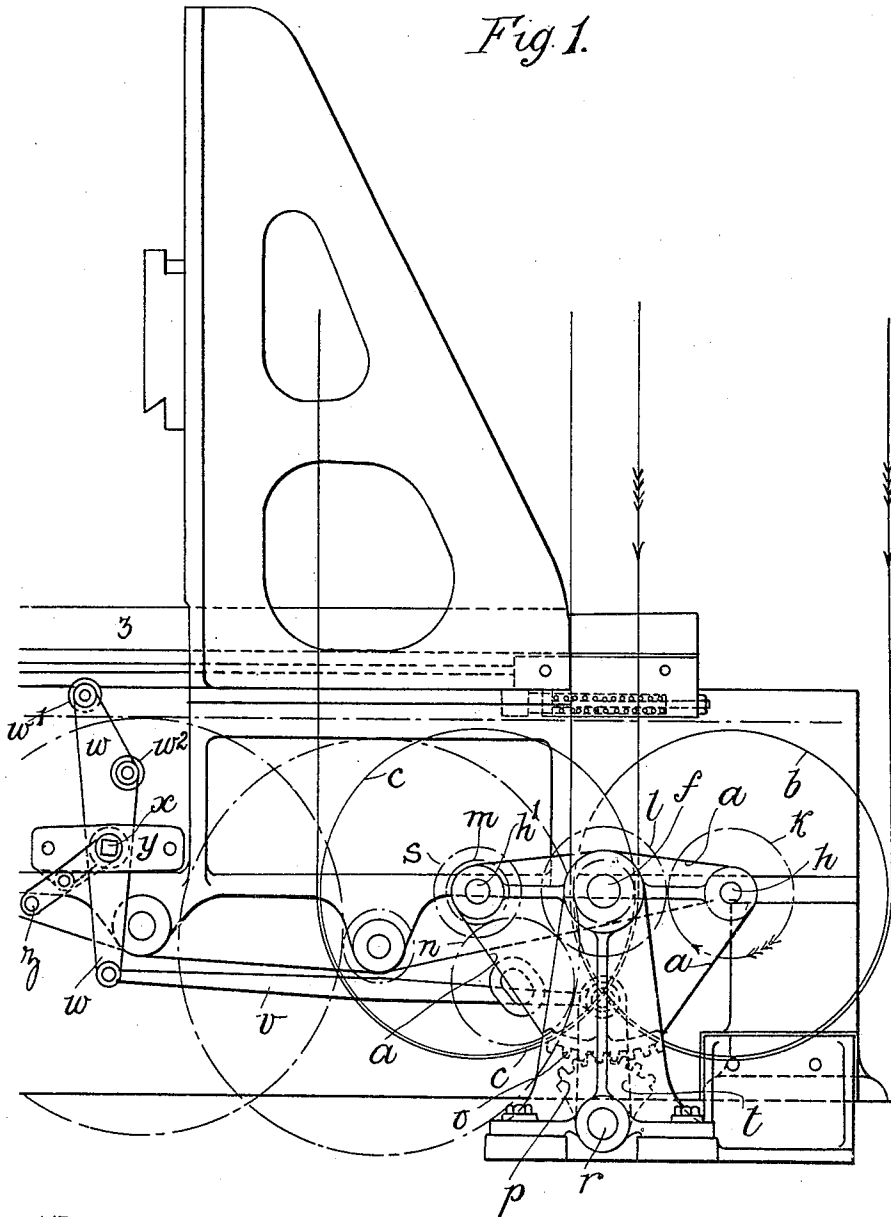

WITNESSES:

Smiller
 John A. Percival

INVENTOR.

John Miley

by *Richard A.*
 ATTYS

J. MILEY.
REVERSING MECHANISM FOR MACHINE TOOLS.

APPLICATION FILED DEC. 20, 1905.

3 SHEETS—SHEET 3.

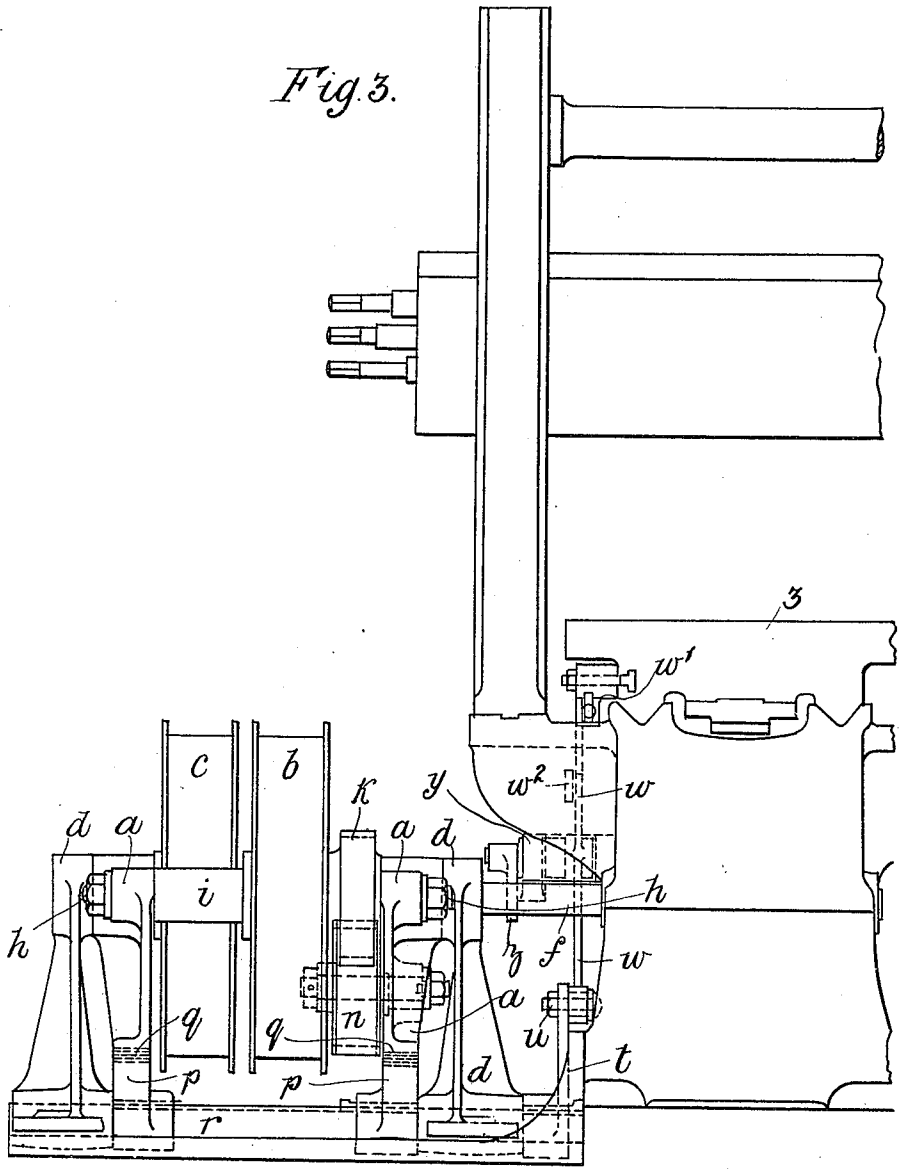

WITNESSES:
Amiller
John A. Perewial.

INVENTOR.
John Miley
Richardson
ATTYS.

UNITED STATES PATENT OFFICE.

JOHN MILEY, OF MANCHESTER, ENGLAND, ASSIGNOR TO CRAVEN BROTHERS, LIMITED, OF MANCHESTER, ENGLAND.

REVERSING MECHANISM FOR MACHINE-TOOLS.

No. 825,231.

Specification of Letters Patent.

Patented July 3, 1906.

Application filed December 20, 1905. Serial No. 292,656.

To all whom it may concern:

Be it known that I, JOHN MILEY, a subject of the King of Great Britain, residing at 12 Mary street, Harpurhey, Manchester, in the county of Lancaster, England, have invented new and useful Improvements in the Reversing Mechanism for Machine-Tools, of which the following is a specification.

This invention relates to improvements in the reversing mechanism of planing-machines and other machine-tools, cranes, and other belt or rope driven mechanisms, and has for its object to effect the automatic reversal of the main driving-shaft of the machine, crane, or other mechanism without shifting belts from fast to loose pulleys.

In carrying the invention into effect a rocking frame carrying two driven pulleys running in the same direction and a geared reversing-motion is mounted to oscillate upon two trunnion-brackets concentric with the driving shaft or screw to be reversed. This rocking frame is approximately triangular in form, is inverted, and has its center of movement in, say, the middle of its base, and at each end of the base is a stud or stay bolt, upon each of which at the opposite corners of the inverted base is fitted a revolving sleeve. On one sleeve is keyed one driven belt-pulley and a spur-wheel in gear with a spur-wheel on the driving-shaft. On the other sleeve is keyed the other driven belt-pulley and a pinion, gearing through an intermediate or carrier wheel with the aforesaid spur-wheel on the driving-shaft. On the apex of the inverted triangular frame is formed or secured toothed quadrants geared with pinions or segments fixed on a shaft which is oscillated by suitable connections from the traveling table or other moving part.

When the base of the inverted triangular frame is in a horizontal position, both the belts on the driving-pulleys are slack, and consequently no motion is transmitted through the gearing to the driving-shaft. When, however, the triangular frame is inclined to one side, the belt on the pulley which is lowered is tightened, and thus the shaft is driven through the gearing in one direction until the triangular frame is oscillated by the connections from the traveling table or other moving part, thus slackening the belt which had been driven and tightening the other belt, which thus becomes the driver and through

the gearing drives the shaft in the reverse direction.

In the accompanying three sheets of drawings, Figure 1 is a side elevation of part of a planing-machine to which my improved reversing mechanism is applied. Fig. 2 is a plan view of Fig. 1 with the reversing mechanism shown in section, and Fig. 3 is an end view of Fig. 1.

In the drawings, *a* designates a rocking frame carrying two pulleys *b c*, driven in the same direction by belts.

d represents two trunnion-brackets upon which the rocking frame carrying the geared reversing-motion is mounted and free to oscillate. These trunnions are concentric with the driving shaft or screw *f* to be reversed. This rocking frame *a* is approximately triangular in form, is inverted, and has its center of movement in, say, the middle of its base and oscillates upon the trunnion-brackets *d*. At each end of the base of the rocking frame is a stud or stay bolt *h h'*, which connect together the two end plates of the rocking frame *a*. Upon the bolts *h h'* are fitted sleeves *i i'*, to which the pulleys *b c* are respectively secured. On the sleeve *i* is also secured a spur-wheel *k*, gearing into a spur-wheel *l* upon the driving shaft or screw *f*. On the other sleeve *i'* is secured the other driven belt-pulley *c* and a pinion *m*, gearing, through an intermediate or carrier wheel *n*, with the aforesaid spur-wheel *l* on the driving-shaft. On the apex of the inverted rocking frame *a* are formed or secured two quadrants *o*, gearing into segments *p*, fixed upon a shaft *r*, carried in the brackets *d*.

To a lever *t* upon the shaft *r* is secured a stud *u*, which serves to connect the lever by a rod *v* to a lever *w*, which carries at its upper end two small bowls *w' w''*. The usual adjustable dogs (not shown) upon the table of the planing-machine act alternately upon one or other of the bowls *w' w''*, and so impart an oscillating movement to the shaft *r*. The lever *w* is keyed on a stud *x*, fitted in a stationary bracket *y*, and upon the squared end of this stud is fitted a handle *z*. The drawings represent the base of the rocking frame *a* in the horizontal position and the belts on the driving-pulleys *b* and *c* slack, so that no motion will be conveyed to the planing-machine.

To start the machine, the operative must move the handle *z*—say to lower it. This will move the lever *w* and rod *y* far enough

to move the lever *t* and cause the shaft *r* and segments *p*, mounted upon it, to turn the rocking frame *a* upon its trunnions *d* by the quadrants *o* far enough for the driving-belt to be drawn tight upon the pulley *c* on the sleeve *i'*, the pinion *m* upon which, by means of the carrier-wheel *n* and toothed wheel *l*, imparts motion to the driving shaft or screw *f* of the machine and sets the reciprocating table *3* in motion, the reversal of direction of the table being controlled by the adjustable stops, which act alternately upon the bowls *w'* *w*² of the lever *w*, as described.

In order to increase the speed of the driving shaft or screw *f* when the machine is cutting, I fit a spur-wheel *s* on a feather-key in the sleeve *i'*. This wheel is hollowed out, as shown in Fig. 2, and when required to increase the speed of the reciprocating table the carrier-wheel *n* is moved down out of gear with the pinion *m*, when the gear *s* can be pushed along the sleeve *i'* into gear with the carrier-wheel *n*, which still remains in gear with the wheel *l*, fast upon the driving shaft or screw *f*, and gives an increased speed to the machine-table.

The direction of rotation of the driving-pulleys *b* *c*, in connection with the gear-reversing wheels *k*, *m*, and *n*, is such that it automatically supplies the necessary tension for driving and does not require any dead-weights, springs, cams, or air-pressure to keep the driving-belt taut. This can be readily understood by referring to Fig. 1, where an arrow indicates the direction of rotation of the spur-wheels *k* and *n* when the spur-wheel *k* is driving the screw *f* through its gear *l*. The resistance before the screw *f* can be set in motion tends naturally to force the wheel *k* to travel round the gear *l*, and so holds the rocking frame *a* in position and automatically supplies the necessary tension to keep the belt taut, and a similar action takes place when the reversing-motion comes into play and the pinion *m* and carrier *n* become the drivers of the wheel *l* and screw *f*. It will be readily understood that instead of

driving the shaft *f* from the belts through the gear the motion might be taken in the reverse way from the shaft *f* through the gear to the belts, and in place of belts ropes might be employed.

Although I have only described my improved reversing-motion as applied to a planing-machine; it is obvious that it can be readily applied to certain other machine-tools, cranes, or other mechanisms.

What I claim, and desire to secure by Letters Patent of the United States, is—

1. In reversing mechanism for machine-tools and the like a rocking frame, a shaft carried on each side thereof, a driving-pulley on each shaft, a shaft for the tool to be reversed, a toothed wheel thereon, gears on the first-mentioned shafts gearing with said wheel, a quadrant on the frame, an oscillating shaft, segments thereon engaging with the quadrant to rock the frame and means for oscillating the shaft.

2. In reversing mechanism for machine-tools and the like, a rocking frame, a shaft on each side thereof, a pulley on each shaft, a toothed wheel on each shaft, a shaft for the machine to be reversed, a toothed wheel thereon, one of the wheels on the shafts of the frame meshing with said wheel and an intermediate wheel meshing with said wheel and the wheel of the other shaft on the frame, a second toothed wheel on said last-named shaft, means permitting movement of the intermediate wheel so as to engage with the second toothed wheel, a quadrant on said rocking frame, a rocking shaft, a segment thereon engaging with said quadrant and means for operating the rocking shaft from the machine.

In testimony whereof I have signed my name to this specification in the presence of two subscribing witnesses.

JOHN MILEY.

Witnesses:

HENRY BERNOULLI BARLOW,
HERBERT R. ABBEY.