

(19) **DANMARK**

(10) **DK/EP 3553251 T3**



Patent- og
Varemærkestyrelsen

(12) **Oversættelse af
europæisk patentskrift**

-
- (51) Int.Cl.: ***E 04 F 15/02 (2006.01)*** ***E 04 F 11/02 (2006.01)*** ***E 04 F 11/035 (2006.01)***
E 04 F 15/024 (2006.01) ***E 04 F 15/04 (2006.01)*** ***E 04 F 15/08 (2006.01)***
E 04 F 15/10 (2006.01) ***E 04 F 15/12 (2006.01)***
- (45) Oversættelsen bekendtgjort den: **2021-10-18**
- (80) Dato for Den Europæiske Patentmyndigheds bekendtgørelse om meddelelse af patentet: **2021-08-11**
- (86) Europæisk ansøgning nr.: **19167153.6**
- (86) Europæisk indleveringsdag: **2019-04-03**
- (87) Den europæiske ansøgnings publiceringsdag: **2019-10-16**
- (30) Prioritet: **2018-04-10 NL 2020738**
- (84) Designerede stater: **AL AT BE BG CH CY CZ DE DK EE ES FI FR GB GR HR HU IE IS IT LI LT LU LV MC MK MT NL NO PL PT RO RS SE SI SK SM TR**
- (73) Patenthaver: **Staco Holding B.V., Molenweg 1, 5953 JR Reuver, Holland**
- (72) Opfinder: **Simons, Tony Petrus Elisabeth, Heikamp 4, 6071 AT Swalmen, Holland**
- (74) Fuldmægtig i Danmark: **Plougmann Vingtoft A/S, Strandvejen 70, 2900 Hellerup, Danmark**
- (54) Benævnelse: **ANORDNING SAMT EN STØTTESTRUKTUR OG EN PROFIL FOR SÅDAN EN ANORDNING**
- (56) Fremdragne publikationer:
CA-A1- 2 715 232
DE-U1-202008 006 944
US-A1- 2005 115 181
US-A1- 2015 128 519
US-B2- 9 010 051

DESCRIPTION

[0001] Assembly as well as a supporting structure and a profile for such an assembly.

FIELD OF THE INVENTION

[0002] The invention relates to an assembly comprising at least one supporting structure and at least two filling elements supported by the supporting structure, which supporting structure comprises at least a first and a second elongated profile, each profile comprising at least a first leg and a second leg, wherein the first legs of the profiles extend in a same plane, whilst the second legs are spaced apart and extend substantially parallel to each other, wherein at least one filling element is supported by a first leg of the first elongated profile.

[0003] The invention further relates to a supporting structure and a profile for such an assembly.

[0004] Such assembly is being used as floors or staircases to support persons and other kind of loads.

BACKGROUND OF THE INVENTION

[0005] By such an assembly which is known from CA2715232A1 there is a raised parapet structure on a first side a each deck portion where part of a web portion bent back on itself and projects above the deck portion. On a second side of each deck portion there is an upstanding rib of complimentary configuration to the parapet of an adjacent joist of the deck assembly. The parapet and rib provide interengaging male and female portions.

[0006] Due to the interengaging male and female portions at each transition from one deck portion to the next deck portion, there are four layers of material between substrates located on the deck portions. Furthermore, due to the interengaging male and female portions, each male and female portion must be accurately be made to be able to be interengaged on the one hand and to avoid play on the other hand. It has to be noted that from a US2015128519A1 an assembly is known whereby a frame portion includes an upper portion comprised of a horizontal panel which spans between an upright flange at a first side and an upright flange at a second side so that the upright flanges form a U-shaped recess with the horizontal panel which is suitable to receive an insert body. The insert body is bounded on its longitudinal sides by flanges of the same frame portion. When positioning a number of frame portions next to each other, an upright flange at a first side of a first frame portion is located against an upright flange at a second side of a second frame portion. This makes the distance between two adjacent insert bodies relatively large.

[0007] By outside use, the known assembly has the disadvantage that rainwater can only leave each frame portion on its longitudinal ends.

[0008] Another disadvantage of such an assembly is that the distance between the two flanges of the frame portion determines the width of the insert body.

[0009] It has to be noted that by an assembly which is known from the Dutch patent NL1030517 the supporting structure is made of a number of spaced apart metal support bars and a number of spaced apart metal filling bars. The filling bars extend perpendicular to the support bars. The support bars are higher than the filling bars. Elongated wooden filling elements are located between the support bars and are supported by the filling bars. The elongated filling elements need to be connected to the supporting structure to obtain a desired stiffness. Due to the combination of elongated wooden filling elements and the metal supporting structure, it is difficult to predict the stiffness and maximum load-carrying capacity. Another disadvantage of this known assembly is that the supporting structure cannot easily be enlarged due to the fixed lengths of the supporting bars and filling bars. Also the method of production is relatively complicated rendering the assembly relatively costly.

[0010] Furthermore it has to be noted that US2005115181A1 discloses a flooring system comprising slabs located between strips. The metal profile of the strip has two vertical lateral flanges and a lower web, defining a receptacle for receiving a lamina. The lower web and the two vertical flanges of each individual strip form a U-shaped receptacle. Tiles without flanges are located between the strips.

SUMMARY OF THE INVENTION

[0011] At least one of the objects of the invention is to provide an assembly which can easily be manufactured at relatively low costs.

[0012] Another object of the invention is to provide an assembly having a relatively high stiffness.

[0013] This object is accomplished with the assembly according to claim 1.

[0014] At the side where the elongated profiles support the filling elements, the elongated profiles are L-shaped.

[0015] To obtain an assembly with a desired width and length, the profiles are made at the desired length. By placing a desired number of profiles next to each other, a supporting structure with the desired width is obtained. Subsequently, between each set of two spaced apart adjacent second legs, a filling element is positioned on the respective first leg and between second legs of the adjacent first and second elongated profiles only.

[0016] The profiles are preferably made of steel, aluminium, stainless steel, composite, plastic or other kind of material being strong enough to support the weight of the filling elements. The stiffness and maximum load-carrying capacity can easily be calculated.

[0017] The filling element does need to be connected to the supporting structure to provide the supporting structure with the desired stiffness. The filling element can be made of any kind of material.

[0018] Only the width of the first leg determines the width of the filing element to be supported by the first leg. By amending the width of the first leg, the elongated profile is suitable for supporting a filing element with a different width, whereby the filing element is bounded on both its longitudinal sides by second legs of the first and second profile. This is useful when a floor to be made has a width not being a round number of times the width of a single profile. For example the profile near the edge of the floor can easily be given the necessary width.

[0019] Since between two adjacent filing elements only one second leg is present, the amount of material need is less than by the assembly according to US20150128519A1 having two flanges between two adjacent filing elements.

[0020] Rainwater can easily leave each profile along nearly the whole longitudinal side at a side remote of the second leg.

[0021] When longitudinal sides of a floor to be made do not exactly extend parallel to each other, the longitudinal sides of profiles located next to each other may include a relatively small angle, which will result over the total number of profiles on the floor to the angle between the longitudinal sides of the floor.

[0022] The assembly according to the invention provides an architect with a large freedom of design.

[0023] The profiles can easily be made so that the costs of the supporting structure are limited.

[0024] Another embodiment of the assembly according to the invention is characterized in that an end of the first leg of the first profile is connected to an end of the first leg of the second profile near its second leg.

[0025] In this manner the first legs form a nearly continuous plane.

[0026] Another embodiment of the assembly according to the invention is characterized in that the end of the first leg of the first profile is connected to the end of the first leg of the second profile by welding.

[0027] In this manner the profiles are permanently connected to each other. In case that profiles should be detachably connected to each other bolts and nuts can be used, for

example. The welding can be made on several spots along the longitudinal sides of the profiles so that rainwater can flow off the first legs of the profiles between the welds.

[0028] Another embodiment of the assembly according to the invention is characterized in that at an end avert of the second leg the first leg is provided with a third leg located at another side of the plane as the second leg.

[0029] Due to such a third leg, the stiffness of the profile is further enlarged.

[0030] Another embodiment of the assembly according to the invention is characterized in that at an end avert of the second leg the first leg is provided with a U-shaped gutter comprising the third leg and a fourth leg connected to each other by a bridge part.

[0031] By outdoor use, such gutter can be used a drainage channel.

[0032] Another embodiment of the assembly according to the invention is characterized in that the first leg of the first profile is supported by the fourth leg of the second profile.

[0033] In this manner the fourth leg serves both as a side wall of the gutter as well as a support for the first leg of the adjacent profile. If desired the fourth leg of one profile can be welded to the first leg of the adjacent profile.

[0034] Another embodiment of the assembly according to the invention is characterized in that the third leg at an end avert of the first leg is provided with a fifth leg extending parallel to the first leg in a direction towards the second leg.

[0035] Due to such fifth leg, the stiffness of the profile is further enlarged.

[0036] Another embodiment of the assembly according to the invention is characterized in that the assembly comprises a number of supporting structures staggered with respect to each other forming a staircase.

[0037] Due to the relatively simple assembly, a staircase with a desired number of stairs can easily be made. The width of each stair will be determined by the length of the profile, whereas the depth of each stairs will at least be determined by the number of profiles the width thereof.

[0038] Another embodiment of the assembly according to the invention is characterized in that the second leg of the first profile of a first supporting structure is elongated, which second leg ends near or at the first leg of a profile of a second supporting structure.

[0039] In this manner the first leg will almost or completely close the space between two stairs and no additional components are needed to close this space.

[0040] Another embodiment of the assembly according to the invention is characterized in that

the first leg is provided with a number of raised portions, each provided with a central hole.

[0041] The at least one filling element is supported by raised portions of the first leg. In this manner the contact surface between the filling element and the first leg is limited. By outside use, rainwater can flow underneath the filling element and over the first leg to a drainage. Due to the central hole the contact surface is further limited. In case of a wooden filling element, the limited contact surface with the first leg makes it possible for the wooden filling element to breath.

[0042] The raised portions will enforce the torsion stiffness of the first leg.

[0043] Another embodiment of the assembly according to the invention is characterized in that the first leg is provided with a number of drainage holes.

[0044] Through said drainage holes rainwater on the first leg can be drained.

[0045] Another embodiment of the assembly according to the invention is characterized in that the second leg extends 1-5 millimetre, preferably 2-3 millimetre above the filling component.

[0046] The part of the second leg extending above the filling component will serve as anti slip for a person walking on the filling components.

[0047] Another embodiment of the assembly according to the invention is characterized in that the second leg at a side avert of the first leg is provided with a serration.

[0048] Due to the serration the anti-slip function of the part of the second leg extending above the filling component is further improved.

[0049] Another embodiment of the assembly according to the invention is characterized in that the filling element comprises an elongated panel of wood, plastic or other material.

[0050] Such panel can be freely positioned in the space bounded by a first leg and two adjacent second legs. If desired the panel can be fixed to the first leg, for example by means of bolts or nails. Preferably only one panel is positioned between two adjacent second legs, so that each panel is bounded on both its longitudinal sides by second legs. However, if desired more than one panel can be positioned between two adjacent second legs.

[0051] Another embodiment of the assembly according to the invention is characterized in that the filling element comprises granulate filling the space between the first leg of the first elongated profile and two spaced apart adjacent second legs.

[0052] Such granulate filling can easily be inserted in the space bounded by a first leg and two adjacent second legs and provides the assembly with a nice appearance.

BRIEF DESCRIPTION OF THE DRAWINGS

[0053] The assembly, supporting structure and profile according to the invention will further be explained with reference to the drawings, wherein,

figure 1 is a perspective view of a first embodiment of an assembly according to the invention,

figure 2 is a perspective view of a profile according to the invention of the assembly as shown in figure 1,

figure 3 is a side view of the assembly as shown in figure 1,

figure 4A and 4B are side views of different embodiments of the profile as shown in figure 2,

figure 5 is a perspective view of a second embodiment of an assembly according to the invention,

figure 6 is a perspective view of a supporting structure according to the invention of the assembly as shown in figure 5,

figure 7 is a perspective view of a U-shaped part of the assembly as shown in figure 5,

figure 8 is a perspective view of a profile according to the invention of the assembly as shown in figure 5,

figure 9 is a perspective view of a third embodiment of an assembly according to the invention,

figure 10 is a perspective view of a profile according to the invention of the assembly as shown in figure 9.

[0054] In the drawings, like reference numerals refer to like elements.

DESCRIPTION OF PREFERRED EMBODIMENTS

[0055] Figures 1-4B shows different views of a first embodiment of an assembly 1 according to the invention. The assembly 1 comprises a supporting structure 2 and four elongated filling elements 3 supported by the supporting structure 2. The supporting structure 2 comprises four identical elongated profile 4. Each profile 4 comprising a first leg 5, a second leg 6 extending perpendicular to the first leg 5 in an upward direction and connected to each other at their ends to form an L-shaped profile, a third leg 7 extending perpendicular to the first leg 5 in a downward direction and connected to the first leg 5 at an end avert of the second leg 6, a bridge part 8 extending parallel to the first leg 5 and connected to the third leg 7 at an end avert of the first leg 5, and a fourth leg 9 extending parallel to the third leg 7 and connected to

the fourth leg 8 at an end avert of the third leg 7.

[0056] The third leg 7, the bridge part 8 and the fourth leg 9 form a U-shaped gutter 10.

[0057] The profile 4 can be made of metal like steel, aluminium or stainless steel. It can also be made of other materials like composite or plastic.

[0058] The first leg 5 is provided with a number of raised portions 11, each provided with a central hole 12. The raised portions 11 can be punched in the first leg 5.

[0059] The first leg 5 is also provided with a number of drainage holes 13. The raised portions 11 and drainage holes 13 are located in a regular pattern forming a grating.

[0060] As can be seen in figure 4A the longitudinal side 14 of the second leg 6 at an end avert of the first leg 5 can be straight.

[0061] As can be seen in figure 4B the longitudinal side 15 of the second leg 6 at an end avert of the first leg 5 can be provided with a serration formed by a number of recesses 16.

[0062] As can be seen in figure 1, a first leg 5 of one profile 4 is supported by an end of the fourth leg 9 of an adjacent profile 4. The height of the fourth profile 9 is such that the first legs of all profiles 4 are located in a same horizontal plane.

[0063] The ends of the profiles 4 can be connected to side plates 17, for example by welding.

[0064] On each first leg 5 an elongated filling element 3 is located. The filling element 3 is an extruded plastic panel, for example. To reduce its weight it is provided with longitudinal channels 18. Such panels are known in the art and will not further be explained. If desired the panel can be fixed to the first leg 30, for example by means of bolts or nails.

[0065] The width W_2 of elongated filling element 3 is slightly smaller than the distance between two adjacent second legs 6 so that the elongated filling element 3 can easily be positioned between the second legs 6 and on the first leg 5. However, it should be wide enough to prevent that for example a stiletto heel of a shoe can get stuck between a side of the elongated filling element 3 and the second leg 6. The profile 4 has a width W_1 being large enough so that the fourth leg 9 of one profile 4 can be abut at a desired distance from the second leg 6 of the adjacent profile 4 to the first leg 5.

[0066] The height H_1 of the elongated filling element 3 is slightly smaller than the height of the second leg 6 above the raised portions 11 so that the second leg extends 1-5 millimetre, preferably 2-3 millimetre above the elongated filling component to provide anti-slippage.

[0067] However, if no such anti-slippage is needed and it is preferred to make the second leg

6 nearly invisible the height H2 of the second leg 6 can be made smaller than the height H1 of the elongated filling element 3.

[0068] Figures 5-8 shows different views of a second embodiment of an assembly 21 according to the invention forming a staircase. The assembly 11 comprises four supporting structure 22 with each two elongated filling elements 23 supported by respective supporting structure 22. Each supporting structure 22 forms a stair of the staircase. Each supporting structure 22 comprises three different elongated profiles 24, 25, 26.

[0069] The first profile 24 is a upside down U-shaped profile comprising two legs 27, 28 connected at their ends by a bridge part 29.

[0070] The second profile 25 comprises a first leg 30, a second leg 31 extending perpendicular to the first leg 30 in an upward direction and connected to each other at their ends to form an L-shaped profile and a third leg 32 extending perpendicular to the first leg 30 in an downward direction and connected to the first leg 30 at an end avert of the second leg 31.

[0071] The first leg 30 and the bridge part 29 are provided with a number of raised portions 11, each provided with a central hole 12. The raised portions 11 can be punched in the first leg 30. The first leg 30 is also provided with a number of drainage holes 13. The raised portions 11 and drainage holes 13 are located in a regular pattern forming a grating.

[0072] Like the longitudinal side 14 of the second leg 6, the longitudinal side 33 of the second leg 31 at an end avert of the first leg 30 can be straight or be provided with a serration formed by a number of recesses 16.

[0073] The third profile 26 is similar to the second profile 25 except that the second leg 34 of the third profile 26 is much longer than the second leg 31 of the second profile 25.

[0074] The ends of the profiles 24, 25, 26 can be connected to side plates 35, for example by welding.

[0075] Furthermore, the transition from the first leg 30 to the second leg 31 of the second profile 25 can be welded to the transition from the first leg 30 to the third leg 32 of the third profile 26. Also the end of the leg 27 can be welded to the transition from the first leg 30 to the third leg 32 of the second profile 25.

[0076] On each first leg 30 an elongated filling element 23 is located. The filling element 23 is a wooden panel, for example. Such panels are known in the art and will not further be explained. If desired the panel can be fixed to the first leg 30, for example by means of bolts or nails.

[0077] To obtain a staircase the desired number of supporting structures 22 with each two elongated filling elements 23 are connected to a wall 36 in a staggered manner, whereby the

second leg 34 of a lower located third profile 26 will be positioned behind the third leg 32 of the second profile 25. If desired it, the respective legs 32, 34 can be connected to each other.

[0078] Figures 9-10 shows different views of a third embodiment of an assembly 41 according to the invention. The assembly 41 comprises a supporting structure 42 and elongated filling elements 43 supported by the supporting structure 42. The supporting structure 42 comprises a number of identical elongated profiles 44. Each profile 44 comprising a first leg 45, a second leg 46 extending perpendicular to the first leg 45 in an upward direction and connected to each other at their ends to form an L-shaped profile, a third leg 47 extending perpendicular to the first leg 45 in a downward direction and connected to the first leg 45 at an end avert of the second leg 46 and a fifth leg 48 extending parallel to the first leg 45 in a direction towards the second leg 46.

[0079] The transition from the first leg 45 to the second leg 46 of one profile 44 is welded at weld 49 to the transition from the first leg 46 to the third leg 47 of an adjacent profile 44.

[0080] The first leg 45 is provided with a number of raised portions 11, each provided with a central hole 12. The raised portions 11 can be punched in the first leg 45. The first leg 45 is also provided with a number of drainage holes 13. The raised portions 11 and drainage holes 13 are located in a regular pattern forming a grating.

[0081] Like the longitudinal side 14 of the second leg 6, the longitudinal side 50 of the second leg 46 at an end avert of the first leg 45 can be straight or be provided with a serration formed by a number of recesses 16.

[0082] On each first leg 45 an elongated filling element 43 is located. The filling element 23 can be a wooden or plastic panel, for example. Such panels are known in the art and will not further be explained. If desired the panel can be fixed to the first leg 45, for example by means of bolts or nails.

[0083] It is also possible to refrain from raised portions 11 and drainage holes 13 in which case the first leg would flat. In such case it would be possible that the filling element comprises granulate filling the space between the first leg of the first elongated profile and two spaced apart adjacent second legs. Drainage holes 13 can be used if the diameter of the drainage holes 13 is smaller than the dimensions of the granulate.

[0084] Other raised portions like rubber elements instead of raised portions 11 with holes 12 to limit the contact area between the first leg and the filling element are also possible.

[0085] It is also possible that the profiles are L-shaped and are provided only with a first leg and a second leg, wherein an end of a first leg avert of the second leg is connected to an end of the adjacent first leg near its second leg.

[0086] It is also possible that the supporting structure comprises an elongated plate with a

number of ribs extending parallel to each other. The ribs can be welded to the plate. At least one filling element is supported by the elongated plate and is located between two spaced apart adjacent ribs. The ribs form the second legs and each part of the plate between two adjacent ribs form first legs.

[0087] The second leg can extend under an angle other than 90 degrees with the first leg, if desired. However, extending perpendicular to the first leg has the advantage that the elongated filling element can have a simple rectangular cross section.

[0088] For example, in case of a granulate as filling element, the supporting structure can be provided with strips extending perpendicular to the first and second legs to form barriers in the space between two adjacent second legs. This makes it easier to maintain the granulate uniformly in the supporting structure.

[0089] It is also possible that the first leg and/or second leg are made of a corrugated sheet.

[0090] It is also possible the elongated profiles have a T-shaped cross-section, with a second leg extending perpendicular to the first leg and connected to the first leg at about the middle thereof. The filling element is supported between two parallel extending T-shaped profiles, and is located on parts of two adjacent two first legs of the adjacent T-shaped profiles, which first legs are directed toward each other.

LIST OF REFERENCE SIGNS

[0091]

- 1 assembly
- 2 supporting structure
- 3 elongated filling element
- 4 profile
- 5 first leg
- 6 second leg
- 7 third leg
- 8 bridge part
- 9

- 10 fourth leg
- 11 U-shaped gutter
- 12 raised portion
- 13 central hole
- 14 drainage hole
- 15 longitudinal side
- 16 longitudinal side
- 17 recess
- 18 side plates
- 21 longitudinal channel
- 22 assembly
- 23 supporting structure
- 24 elongated filling element
- 25 first profile
- 26 second profile
- 27 third profile
- 28 leg
- 29 leg
- 30 bridge part
- 31 first leg
- 32 second leg
- 33 third leg

longitudinal side
34
second leg
35
side plate
36
wall
41
assembly
42
supporting structure
43
elongated filling element
44
elongated profile
45
first leg
46
second leg
47
third leg
48
fifth leg
49
weld
50
longitudinal side
H1
height
H2
height
W2
width
W1
width

REFERENCES CITED IN THE DESCRIPTION

Cited references

This list of references cited by the applicant is for the reader's convenience only. It does not form part of the European patent document. Even though great care has been taken in compiling the references, errors or omissions cannot be excluded and the EPO disclaims all liability in this regard.

Patent documents cited in the description

- CA2715232A1 [0005]
- US2015128519A1 [0006]
- NL1030517 [0009]
- US2005115181A1 [0010]
- US20150128519A1 [0019]

Patentkrav

- 1.** Anordning (1) omfattende mindst én støttestruktur (2) og mindst to fyldelementer (3) støttet af støttestrukturen (2), hvilken støttestruktur (2) omfatter mindst en første og en anden langstrakt profil (4), hvor hver profil
- 5 omfatter mindst et første ben (5) og et andet ben (6), hvor de første ben (5) af profilerne (4) strækker sig i et samme plan, mens de anden ben (6) er anbragt med afstand og strækker sig i alt væsentligt parallelt med hinanden, hvor mindst ét fyldelement (3) er støttet af et første ben (5) af den første langstrakte profil (4)
- kendetegnet ved, at** de første og anden ben (5, 6) af den langstrakte profil (4)
- 10 strækker sig vinkelret på hinanden og er forbundet til hinanden ved deres ender for at danne en L-formet profil, hvor det mindst ene fyldelement (3) er lokaliseret i et rum afgrænset i en retning vinkelret på langsgående sider af de anden ben (6) af det andet ben (6) af den første langstrakte profil (4) og det andet ben (6) af den tilstødende anden langstrakte profil (4).
- 15
- 2.** Anordning (1) ifølge krav 1, **kendetegnet ved, at** en ende af det første ben (5) af den første profil (4) ved en side afsides af det andet ben (6) af den første profil (4) er forbundet til en ende af det første ben (5) af den anden profil (4) nær det andet ben (6) af den anden profil (4).
- 20
- 3.** Anordning (1) ifølge krav 2, **kendetegnet ved, at** enden af det første ben (5) af den første profil (4) er forbundet til enden af det første ben (5) af den anden profil (4) ved svejsning (49).
- 25 **4.** Anordning (1) ifølge et af de foregående krav, **kendetegnet ved, at** ved en ende vendt bort fra det andet ben (6) det første ben (5) er forsynet med et tredje ben (7) lokaliseret ved en anden side af planet som det andet ben (6).
- 5.** Anordning (1) ifølge krav 4, **kendetegnet ved, at** ved en ende vendt bort fra
- 30 det andet ben (6) det første ben (5) er forsynet med en U-formet rende (10) omfattende det tredje ben (7) og et fjerde ben (9) forbundet til hinanden med en brodel (8).

- 6.** Anordning (1) ifølge krav 5, **kendetegnet ved, at** det første ben (5) af den første profil (4) er støttet af det fjerde ben (9) af den anden profil (4).
- 7.** Anordning (1) ifølge et af de foregående krav 5-7, **kendetegnet ved, at** det 5 tredje ben (7) ved en ende vendt bort fra det første ben (5) er forsynet med et femte ben (48) der strækker sig parallelt med det første ben (5) i en retning mod det andet ben (6).
- 8.** Anordning (1) ifølge et af de foregående krav, **kendetegnet ved, at** 10 anordningen (1) omfatter et antal af støttestrukturer (2) forskudt i forhold til hinanden for at danne en trappe.
- 9.** Anordning (1) ifølge krav 8, **kendetegnet ved, at** det andet ben (6) af den første profil (4) af en første støttestruktur (2) er langstrakt, hvilket andet ben 15 (34) ender nær eller ved det første ben (5) af en profil (4) af en anden støttestruktur (2).
- 10.** Anordning ifølge et af de foregående krav, **kendetegnet ved, at** det første ben er forsynet med et antal af hævede dele, hver forsynet med et centralt hul. 20
- 11.** Anordning (1) ifølge et af de foregående krav, **kendetegnet ved, at** det første ben (5) er forsynet med et antal af afløbshuller (13).
- 12.** Anordning (1) ifølge et af de foregående krav, **kendetegnet ved, at** det 25 andet ben (6) strækker sig 1-5 millimeter, fortrinsvis 2-3 millimeter over fyldkomponenten (3).
- 13.** Anordning (1) ifølge et af de foregående krav, **kendetegnet ved, at** det andet ben (6) ved en side vendt bort fra det første ben (5) er forsynet med en 30 savtakning (16).

14. Anordning (1) ifølge et af de foregående krav, **kendetegnet ved, at** fyldelementet (3) omfatter en langstrakt plade af træ, plast eller andet materiale.

15. Anordning (1) ifølge et af de foregående krav, **kendetegnet ved, at**
5 fyldelementet (3) omfatter granulat, som fylder mellemrummet mellem det første ben (5) af den første langstrakte profil (4) og to med afstand anbragte tilstødende anden ben (6).

16. Støttestruktur (2) egnet til at blive anvendt som støttestrukturen (2) af
10 anordningen (1) ifølge krav 1 og omfattende mindst en første og en anden langstrakt profil (4), hvor hver profil omfatter mindst et første ben (5) og et andet ben (6), hvor de første ben (5) af profilerne (4) strækker sig i et samme plan, mens de anden ben (6) er anbragt med afstand og strækker sig i alt væsentligt parallelt med hinanden, hvor mindst ét fyldelement (3) er støttet af et første ben
15 (5) af den første langstrakte profil (4) **kendetegnet ved, at** de første og anden ben (5, 6) af den langstrakte profil (4) strækker sig vinkelret på hinanden og er forbundet til hinanden ved deres ender for at danne en L-formet profil, hvor det mindst ene fyldelement (3) er lokaliseret i et rum afgrænset i en retning vinkelret på langsgående sider af de anden ben (6) af det andet ben (6) af den første
20 langstrakte profil (4) og det andet ben (6) af den tilstødende anden langstrakte profil (4).

17. Profile (4) egnet til at blive anvendt som profilen (4) af støttestrukturen (2) af anordningen (1) ifølge krav 1, omfattende mindst et første ben (5) og et andet
25 ben (6), hvor de første ben (5) af profilerne (4) strækker sig i et samme plan, mens de anden ben (6) er anbragt med afstand og strækker sig i alt væsentligt parallelt med hinanden, hvor mindst ét fyldelement (3) er støttet af et første ben (5) af den første langstrakte profil (4) **kendetegnet ved, at** de første og anden ben (5, 6) af den langstrakte profil (4) strækker sig vinkelret på hinanden og er
30 forbundet til hinanden ved deres ender for at danne en L-formet profil, hvor det mindst ene fyldelement (3) er lokaliseret i et rum afgrænset i en retning vinkelret på langsgående sider af de anden ben (6) af det andet ben (6) af den første langstrakte profil (4) og det andet ben (6) af den tilstødende anden langstrakte profil (4).

DRAWINGS

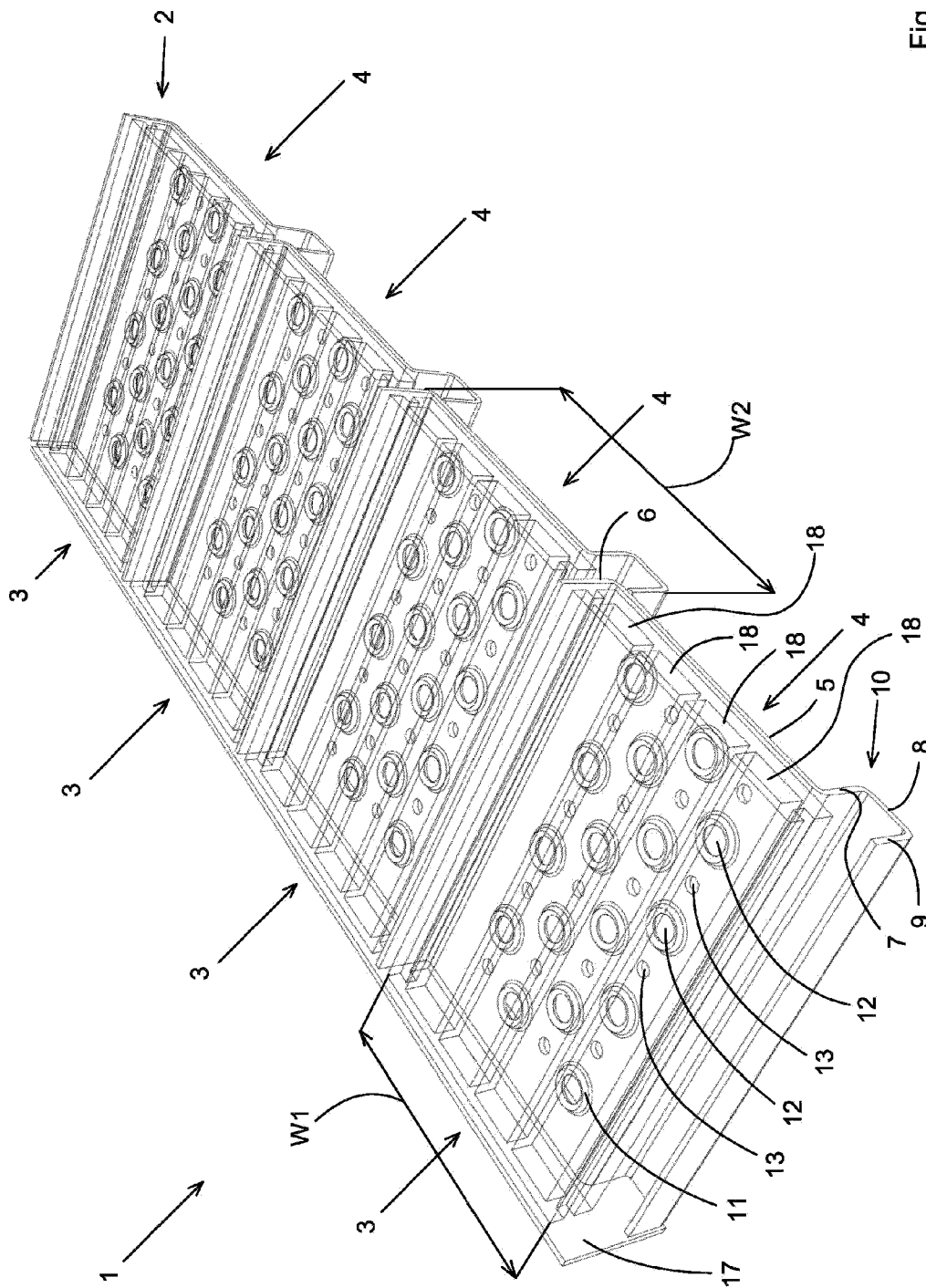

Fig.1

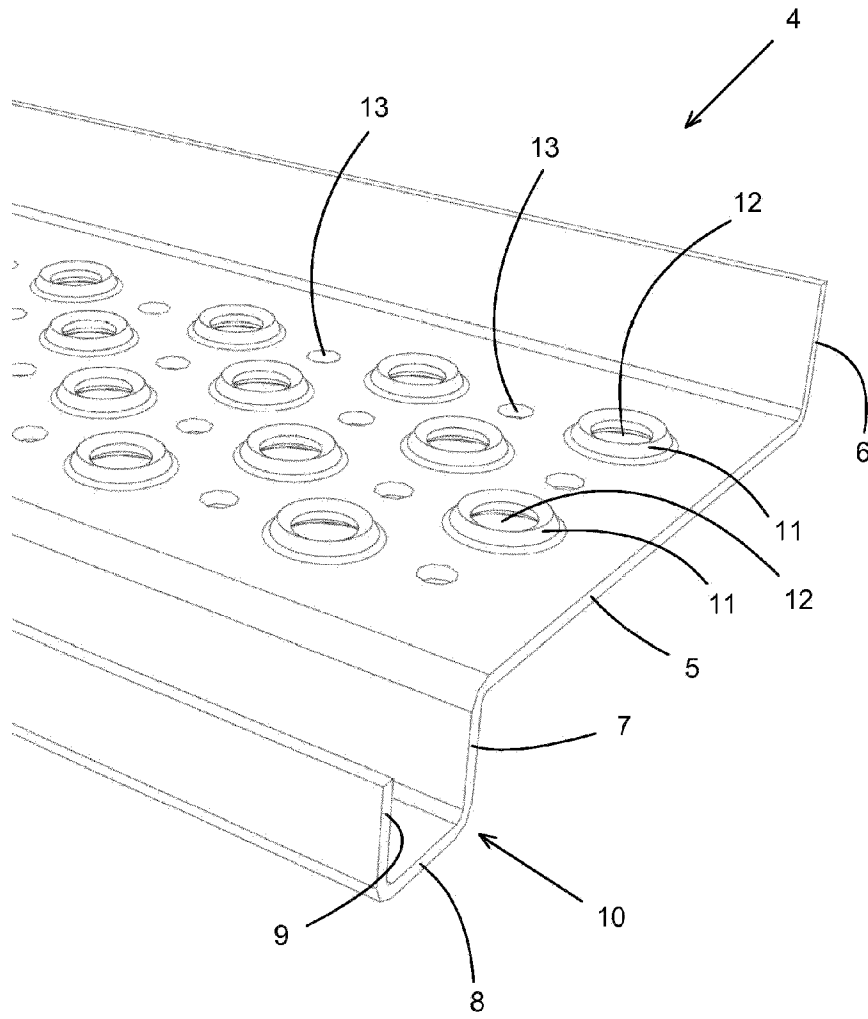

Fig.2

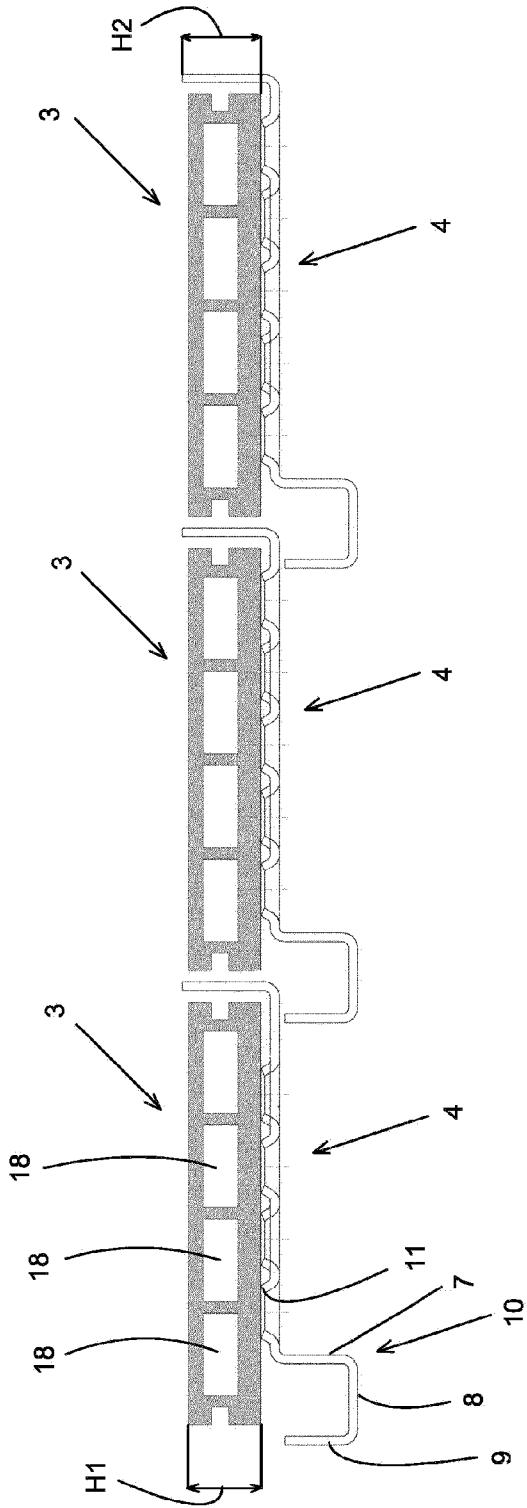
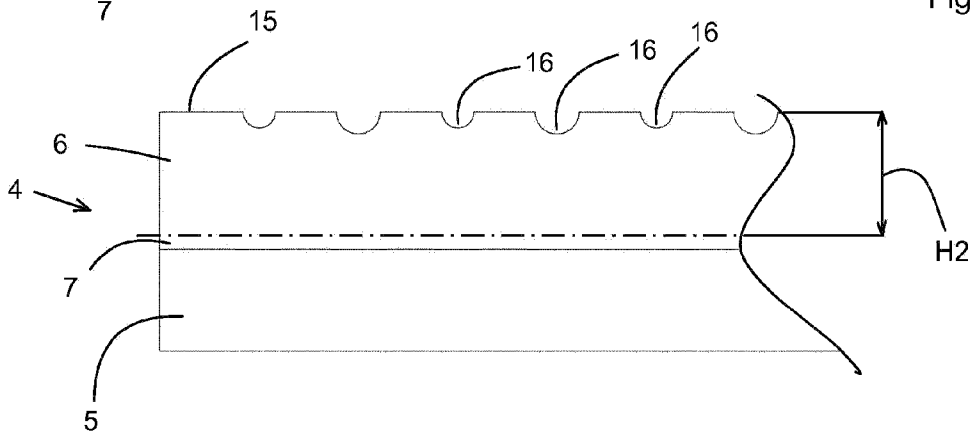
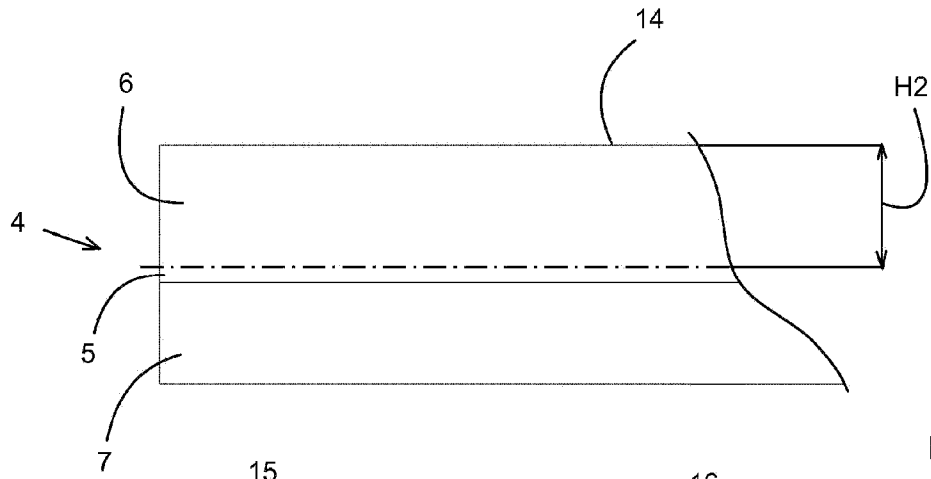

Fig.3



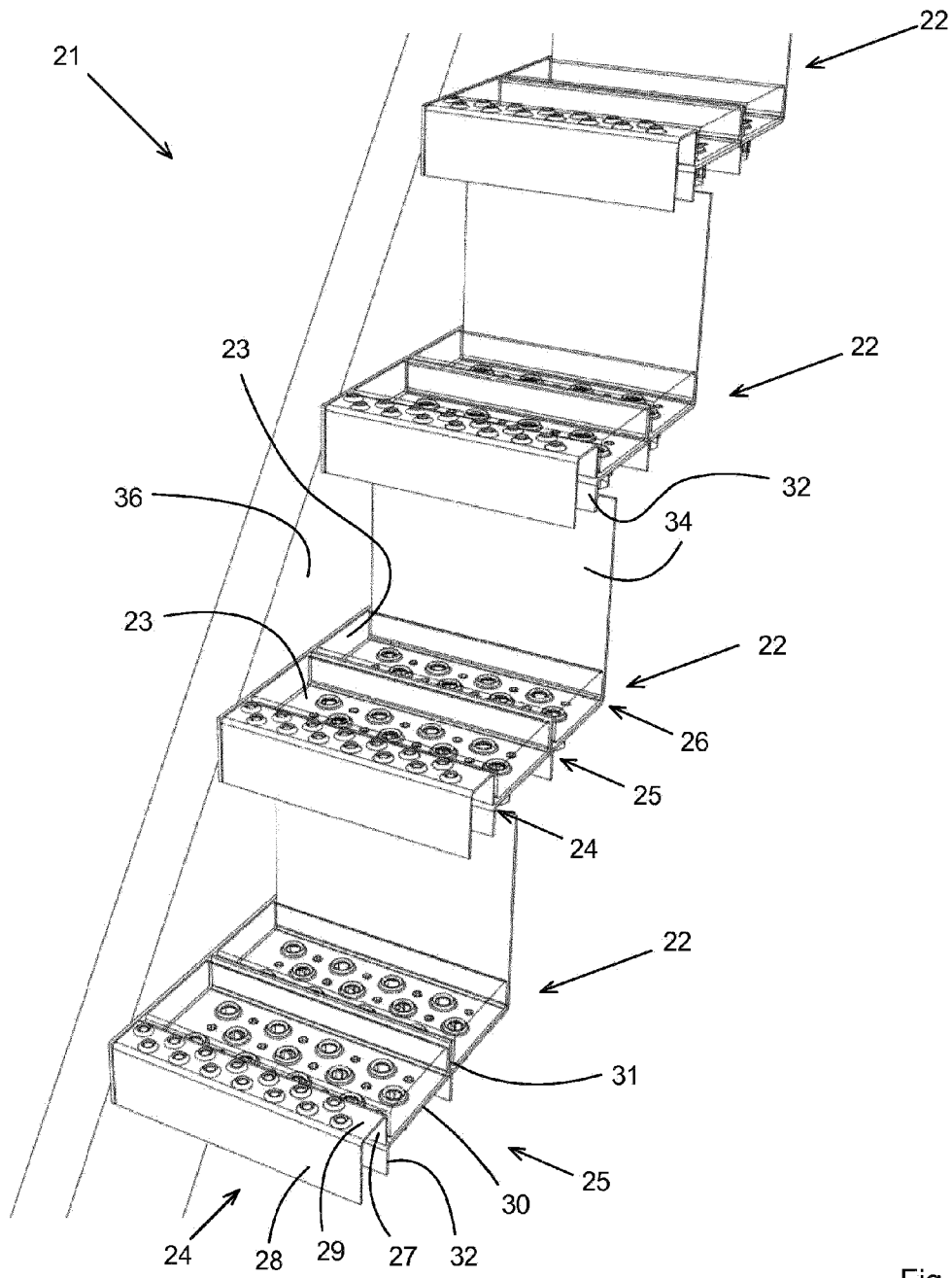

Fig.5

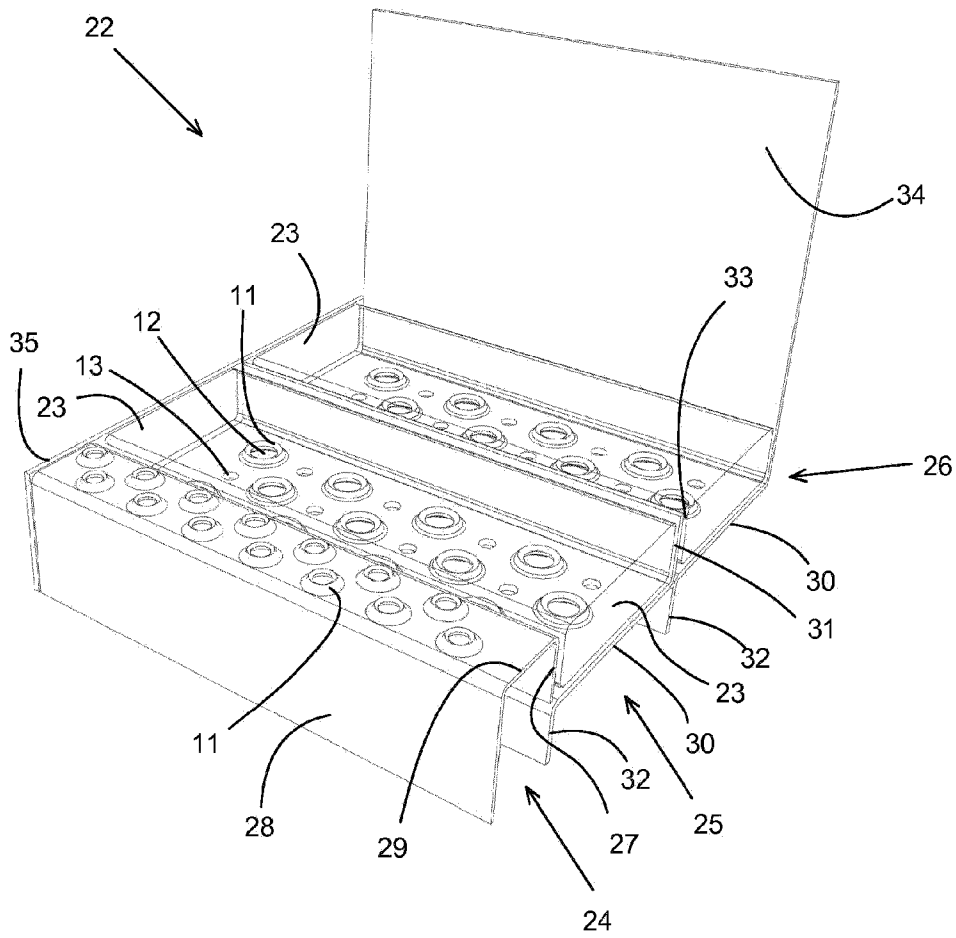

Fig.6

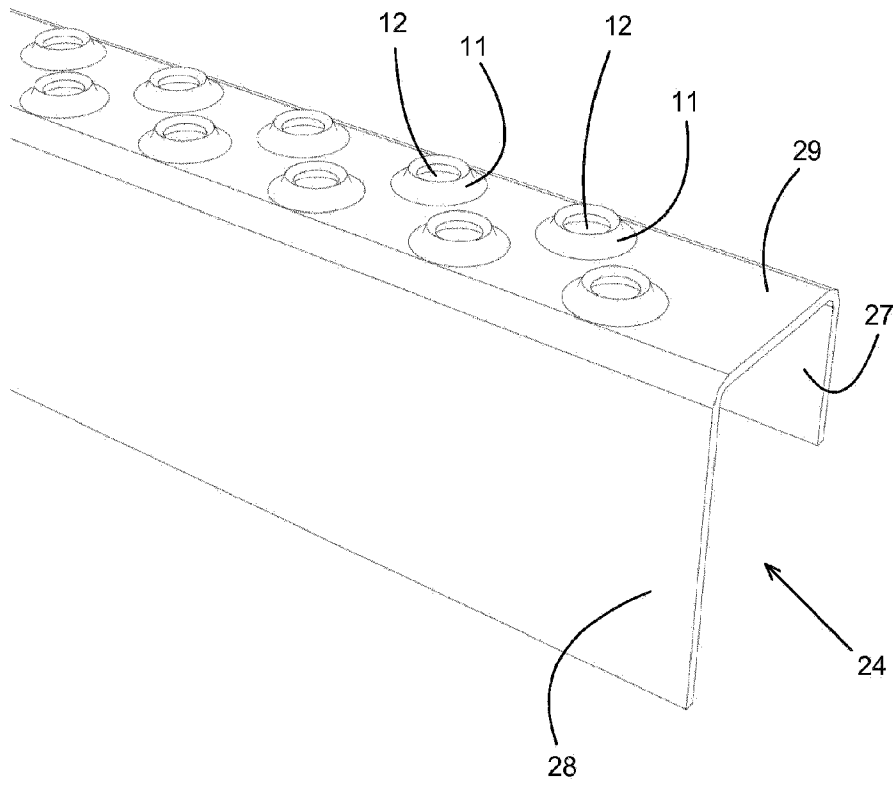

Fig.7

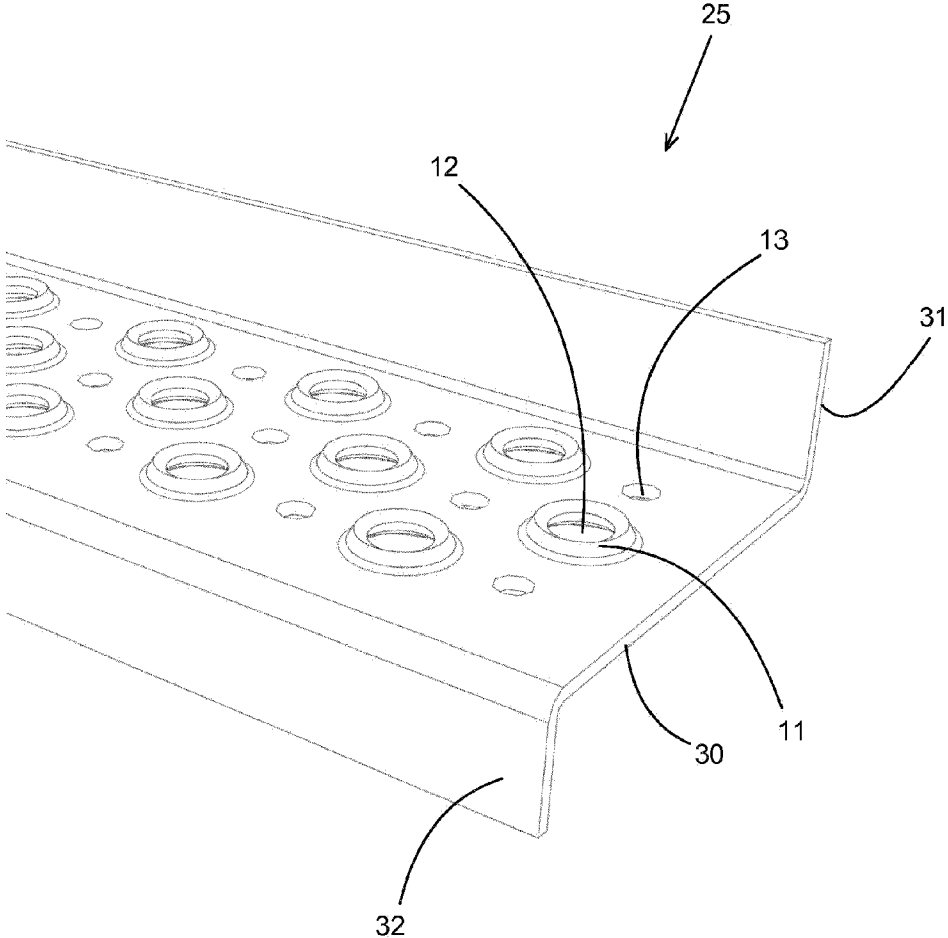

Fig.8

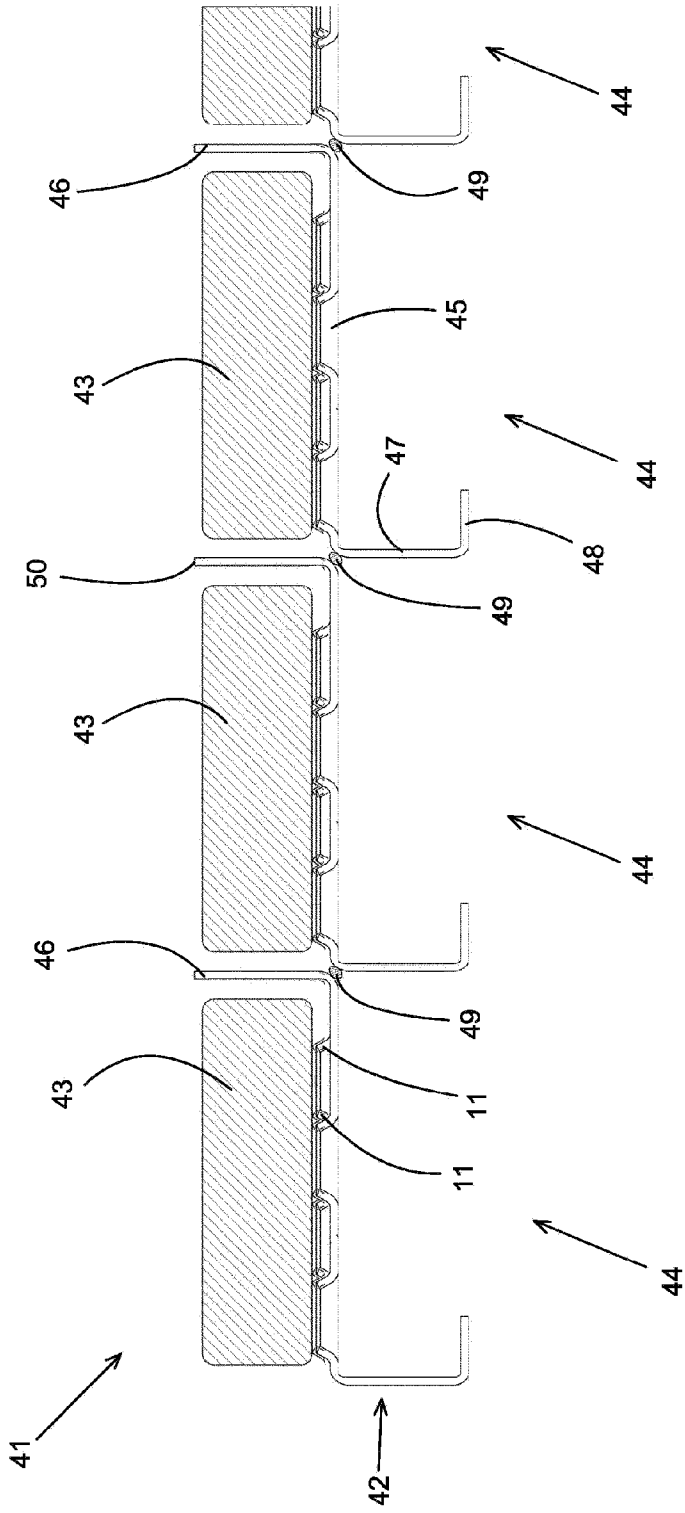

Fig.9

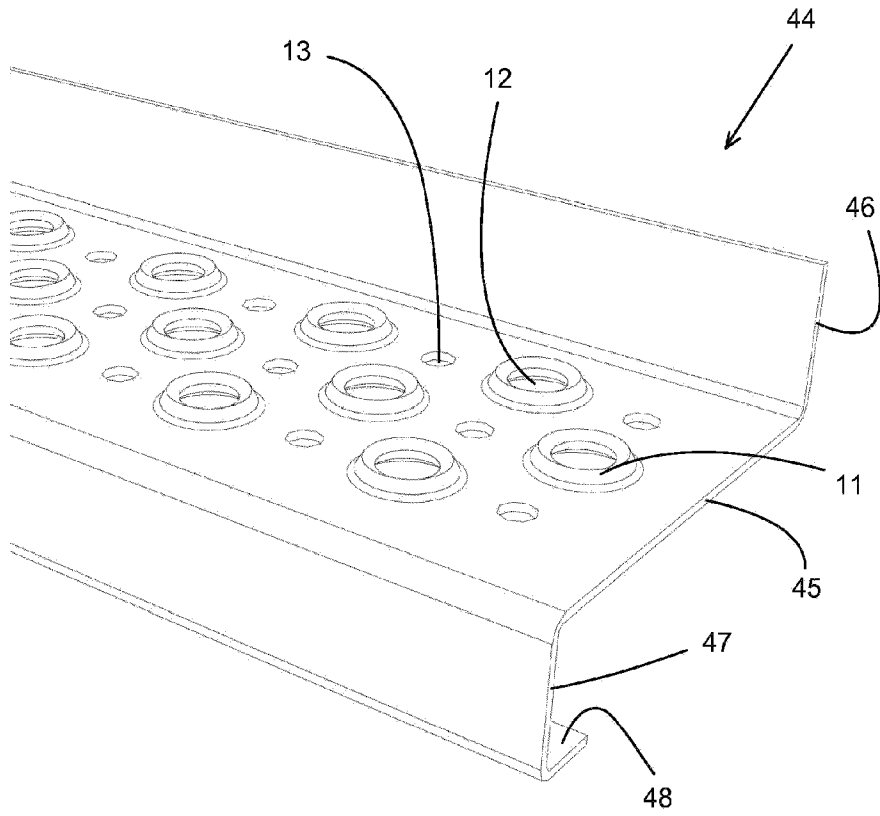

Fig.10