

(No Model.)

2 Sheets—Sheet 1.

E. B. STIMPSON.
PUNCHING MACHINE.

No. 525,872.

Patented Sept. 11, 1894.

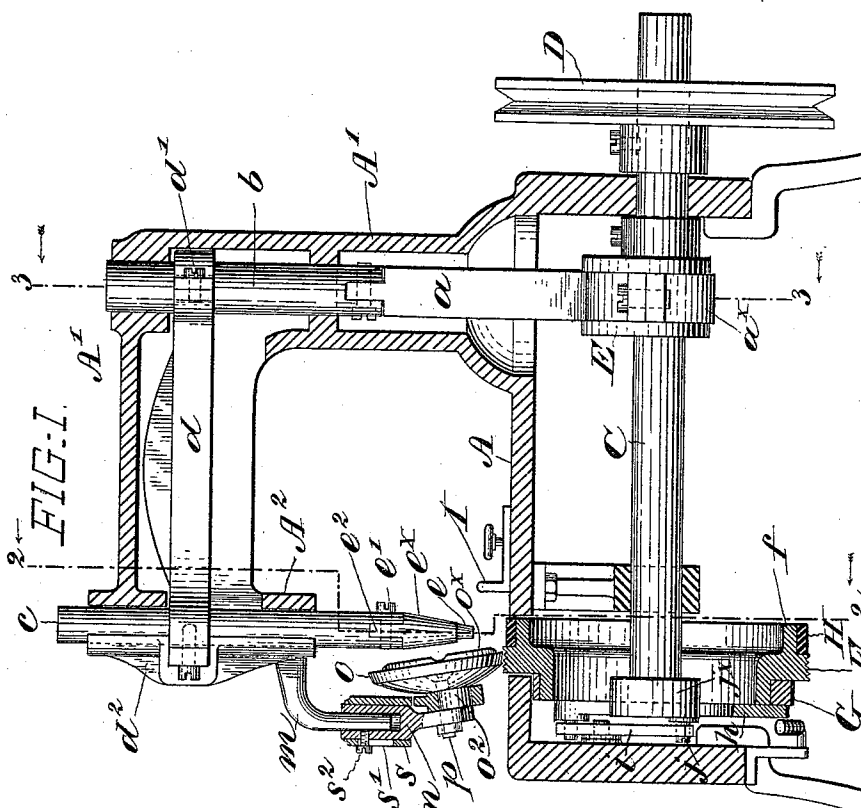
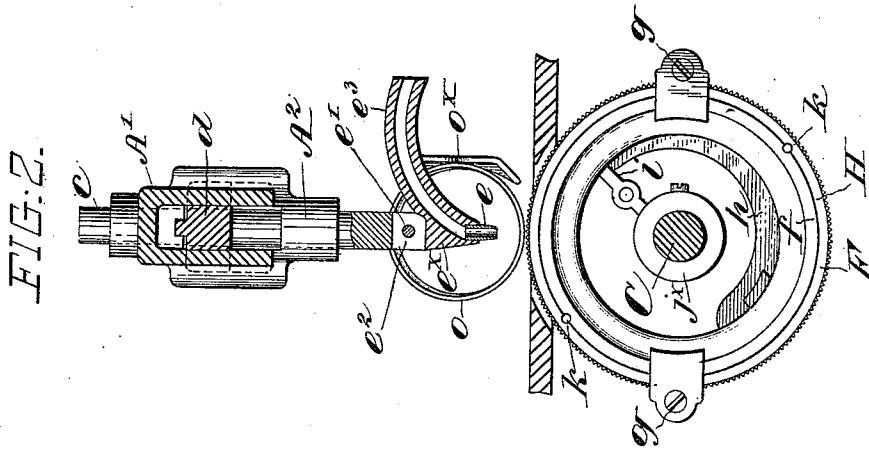

Witnesses:
J. W. Wilman
Peter A. Ross

Inventor:
Edward B. Stimpson
by *Henry Comstock*
his Attorney

UNITED STATES PATENT OFFICE.

EDWIN B. STIMPSON, OF BROOKLYN, NEW YORK.

PUNCHING-MACHINE.

SPECIFICATION forming part of Letters Patent No. 525,872, dated September 11, 1894.

Application filed September 23, 1893. Serial No. 486,293. (No model.)

To all whom it may concern:

Be it known that I, EDWIN B. STIMPSON, a citizen of the United States, residing at Brooklyn, in the county of Kings and State of New York, have invented certain new and useful Improvements in Punching-Machines, of which the following is a specification.

This invention relates to the class of machines employed for punching a series of holes in material fed intermittently under a reciprocating punch; and the object of the invention is, in part, to provide the feed-wheel of the machine with a removable, ring cutting bed fitted on a flange on the feed-wheel; in part to provide the tubular punch with a curved horn having a bore which forms a continuation of the punch, whereby the bits of soft material removed by the punch are carried away; in part to provide an interchangeable presser-foot, and in part to improve the general construction of the machine, all as will be hereinafter described.

In the accompanying drawings—Figure 1 is a longitudinal vertical mid-section of a machine embodying my improvements. Fig. 2 is a vertical transverse section in the plane indicated by line 2, 2, in Fig. 1. Fig. 3 is a transverse vertical section on line 3, 3, in Fig. 1. Figs 4 and 5 are views of the presser-foot, detached. Fig. 6 is a detached view of the feed-wheel and its appurtenances, seen from the left in Fig. 1. Figs. 7 and 8 are, respectively, a face view and sectional view, of the crank which actuates the feed. Fig. 9 is a plan view of the horizontal connecting bar, detached. Fig. 10 is a view of the punch and plunger, detached. This view shows the parts as seen from the left in Fig. 1.

A represents the bed of the machine and A' the standard. These form the frame of the machine and may be of cast iron, integral, and cored out as seen in Fig. 1. Mounted rotatively in the bed A, is a shaft, C, provided with a sheave or pulley, D, for driving. Fixed on the shaft is an eccentric, E, which is embraced by a yoke, a^x, on a rod, a. This rod is coupled at its upper end to a slide, b, mounted in slide-bearings in the standard. In the head, A², which forms a part of the standard, is mounted a plunger, c, parallel with the slide b, and this slide and the plunger are connected

by a bar d, which plays in a cored out recess in the overhanging part of the standard A'. At one end this bar is secured to the slide b, by a clamping-piece, d', and attaching screws, and at its other end it is secured to the plunger c, by a long clamping-piece, d². The construction of these parts is clearly shown in Fig. 9, where the clamping-piece d² and a part of the bar d, are represented in section. Rotation of the shaft C imparts a vertical reciprocating motion to the plunger c through the medium of the eccentric E, slide b, and connecting bar d.

The tubular punch, e, is secured in a punch-carrier, e^x, which is hollow and is secured to the lower end of the plunger by a screw, e', which passes through a tenon, e², on the carrier, said tenon fitting into a slot formed in the lower extremity of the plunger. In order that the bits or pieces of material cut out by the punch may be carried off and delivered at a distance from the punching point, where they would otherwise fall and obscure the work, the carrier e^x, is provided with a curved, tubular horn, e³, the bore in which communicates at its receiving end with the hollow of the punch e, as clearly shown in Fig. 2 and forms a continuation of same. The bits of material from the punch are driven upward and out through the horn e³, and fall from the delivery end thereof at a considerable distance from the punching point. The horn may be of any convenient length, and it will be arranged by preference, so as to deliver the bits ahead, or in the direction of the feed.

It is not new to provide a punching machine with a box-like receptacle housing the upper end of the punch tube, to receive the bits cut out by the punch and to provide this receptacle with a discharging tube; but I find that where the bits punched out are of soft material the only way to effect a clearance is to make the bore in the off-bearing tube or horn continuous with that in the punch out to the delivery end, and to curve this horn so as to direct the delivery where required.

The feed is effected by a serrated feed-wheel, F, driven forward intermittently by mechanism similar to that employed in some kinds of sewing machines. On the bed is fixed by screws, g, a ring holder G for the

feed-wheel F. A friction shoe, *h*, provided with a retracting spring, *h*^x, (seen in Fig. 6) bears on the feed-wheel, when said shoe is moved in a direction to put its spring *h*^x, under tension. On one end of the shoe *h*, is a laterally projecting stud, *h*¹, which is in the path of the outer, short arm of a rocking lever, *i*, fulcrumed on the frame. The other or inner arm of the lever *i* is in the path of the pin, *j*, of a crank-disk *j*^x, on the end of the shaft C, whereby, when said shaft rotates, the crank-pin *j*, acts on and rocks the lever *i*, causing the outer arm of said lever to act on the stud *h*¹, and shift the shoe *h*. The shoe bites on and shifts the feed-wheel in a well known way. In order to adjust the movement of the feed-wheel to that of the punch, the eccentric E may be shifted about the shaft C; and in order to vary the feed to suit the size of the punch, or the distance apart of the holes punched, the crank-pin *j*, may be set nearer to or farther from the axis of the shaft C. This may be effected by the construction illustrated in Figs. 7 and 8. A dovetail or undercut groove, *j*¹, is cut diametrically across the face of the crank-disk *j*^x, and in it is placed a slide-block *j*². The crank-pin, *j*, is a screw which passes through a clamping-washer, *j*³, and screws into the block *j*². By screwing in the pin the block and washer are clamped fast to the crank-disk.

To provide a cutting bed for the punch *e*, the feed-wheel F is furnished with a flange, *f*, which is rabbeted to receive a ring, H, of brass, copper, or other suitable metal or material to receive and form a bed for a cutting punch. This ring H will fit the bearing flange snugly. It will be situated directly under the punch, and its outer periphery will coincide, substantially, with the base of the teeth on the feed-wheel, so that when the material to be punched is in place and pressed down upon the feed-wheel it will rest solidly on the ring H which forms the punching bed. This ring moves, of course, with the feed-wheel and material, and therefore the punch will not touch it twice in succession at the same point. It is contemplated that the ring H will fit quite snugly and tightly on the bearing flange so as not to slip thereon, but as a precautionary device, a hole or holes may be drilled, half in the bearing flange and half in the ring H, and pins or screws, *k* (seen in Fig. 2) be set therein.

I am aware that, broadly speaking, it is not new to provide a punching machine with a punching bed which shifts at each punching operation and I do not claim this. In my construction the removable punching bed is mounted on a flange or rim on the feed-wheel and the material punched moves in a plane tangent to the punching bed.

To keep the goods or material pressed down upon the feed-wheel a presser-foot is employed; and for some kinds of goods a rolling foot is preferred while for other kinds a non-rolling foot is desirable. The presser-foot

herein shown is compound, or presses both of these forms of feet or pressers, either of which may be used, at will.

Figs. 1, 4 and 5 illustrate the construction of the foot best. On an arm, *m*, on the head of the machine, is adjustably mounted a socket-piece, *n*; and on this socket-piece is rotatively mounted a wheel, *o*, which forms the rolling foot. This wheel turns about a screw, *p*, set in the pendent portion of the socket-piece *n*. The non-rolling foot, *o*^x, may be brought down into operative position, as seen in Fig. 4, or be turned up so as to be inoperative, as seen in Figs. 1, 2 and 5. The non-rolling foot *o*^x has a flat stem, *o*¹, through which the screw *p* passes, and where the screw passes through said stem, the screw is embraced by an eccentric, *o*², which may be secured to the pendent portion of the socket-piece *n*. The non-rolling foot swings about this eccentric, whereby when the said foot is down in operative position, as in Fig. 4, it stands somewhat below the level of the rolling foot. This eccentric is not absolutely essential, as the non-rolling foot might swing concentrically with the rolling foot. To hold the non-rolling foot *o*^x in either of its two positions, two notches or recesses, *r*, are formed in its stem, either of which may be made to engage with a locking stud, *s*^x, on a vertically sliding sleeve, *s*, on the socket-piece *n*. The slide *s* has in it a slot, *s*¹, (seen in Fig. 1) in which plays the set-screw, *s*², which clamps the socket-piece *n* in place on the arm *m*.

I is the feed-guide, mounted adjustably on the bed A.

I do not limit myself to the precise construction and arrangement of parts as herein shown as these may be varied to some extent without departing materially from my invention.

If the punch is designed for ornamenting the margins of leather tips and the like, it may be made to punch a hole of any form desired, as circular, square, triangular, &c. The punches may be readily interchanged by simply removing the carrier and substituting another in its place. The punch need not be removed from the carrier for this purpose.

When the ring-shaped punching bed becomes too much roughened and worn for use, it may be replaced by another.

Having thus described my invention, I claim—

1. In a punching machine, the combination with a reciprocating cutting punch and a stationary bed to support the material to be punched, of a serrated feed-wheel which projects up through an aperture in the bed, a presser-foot arranged over the said feed-wheel, and a removable punching bed carried by said feed-wheel and projecting also through the aperture in the bed, substantially as set forth.

2. In a punching machine, the combination with an apertured, stationary bed to support the goods to be punched, and a reciprocating

cutting punch, of an intermittently rotating, serrated feed-wheel which projects up through the aperture in the supporting bed and is provided with a bearing flange *f*, adjacent to the serrated face, a removable ring-like punching bed mounted on the flange *f* under the punch, and a presser-foot arranged over the serrated face of the feed-wheel, substantially as set forth.

10 3. In a punching machine, the combination with an apertured, stationary bed A, a reciprocating cutting punch, and a feed-wheel F, provided with a serrated feeding surface and a lateral flange *f*, of a presser-foot arranged
15 over the feed-wheel, a ring-shaped punching bed H, mounted removably on the said flange, and means for preventing the rotation of the said punching bed about the flange, substantially as set forth.

20 4. In a punching machine, the combination with a reciprocating punch and an intermittent feeding mechanism for the material, of a compound presser-foot, comprising a rolling foot, *o*, a non-rolling foot, *o*^x, adapted to be
25 turned up out of the way when not in use, and means substantially as described for holding said non-rolling foot in either of its two positions, the non-rolling foot taking under the rolling foot when down in use.

30 5. In a punching machine, the combination with a reciprocating punch and an intermittent feeding mechanism for feeding the material under the punch, of the presser-foot, comprising the socket-piece, *n*, the arm, *m*, on
35 which said piece is mounted, the rolling foot, *o*, mounted on the pendent portion of the socket-piece, the screw, *p*, the non-rolling

foot, *o*^x, having a stem, *o*['], provided with two notches *r*, and the sliding locking sleeve *s*, mounted on the socket-piece and provided
40 with a locking stud to engage the said notches in the stem of the non-rolling foot, as set forth.

6. In a punching machine, a tubular punch having the upper end of its straight bore connected with and registering with a curved bore
45 which forms a continuation and prolongation of the bore in the punch and serves to carry away and deliver the bits removed by the punch.

7. In a punching machine, the combination with the reciprocating plunger, of the tubular punch-carrier mounted on the plunger and having a laterally projecting horn provided
50 with a curved bore which forms a prolongation of the socket in the carrier which receives the punch, and the said punch, all arranged to operate substantially as set forth.

8. In a punching machine, the combination with the reciprocating plunger, slotted at its
60 lower end, of the hollow punch carrier provided with a tenon to engage said slot and an integral, laterally projecting, tubular horn, the screw which secures the carrier to the plunger, and the punch set in the carrier, sub-
65 stantially as set forth.

In witness whereof I have hereunto signed my name in the presence of two subscribing witnesses.

EDWIN B. STIMPSON.

Witnesses:

HENRY CONNETT,
JAMES K. DUFFY.