

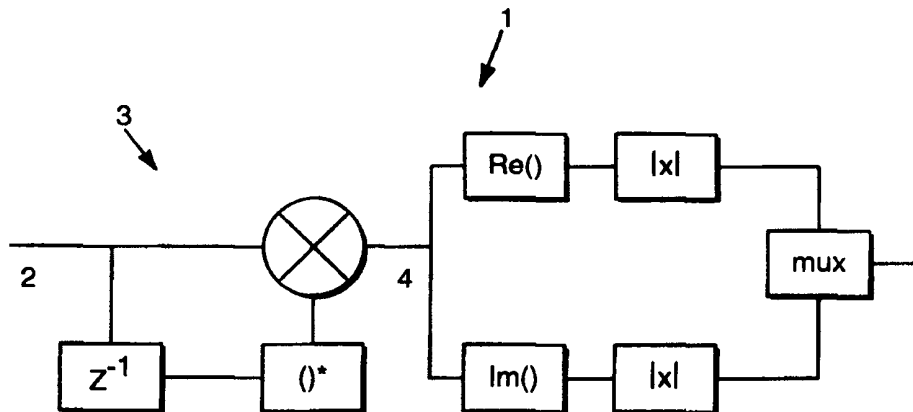

INTERNATIONAL APPLICATION PUBLISHED UNDER THE PATENT COOPERATION TREATY (PCT)

<p>(51) International Patent Classification <sup>6</sup> : <b>H04B 17/00</b></p>	<p><b>A3</b></p>	<p>(11) International Publication Number: <b>WO 99/59274</b> (43) International Publication Date: 18 November 1999 (18.11.99)</p>
<p>(21) International Application Number: PCT/GB99/01532 (22) International Filing Date: 14 May 1999 (14.05.99) (30) Priority Data: 9810395.5 14 May 1998 (14.05.98) GB (71) Applicant (for all designated States except US): SIMOCO INTERNATIONAL LIMITED [GB/GB]; St. Andrews Road, P.O. Box 24, Cambridge CB4 1DP (GB). (72) Inventors; and (75) Inventors/Applicants (for US only): HILLIER, Adrian, Paul [GB/GB]; 31 Greenways Crescent, Bury St. Edmund, Suffolk IP32 7JP (GB). FRAYLING-CORK, Robert, Maxwell [GB/GB]; 30 Victoria Park, Cambridge CV4 3EL (GB). (74) Agent: FRANK B. DEHN &amp; CO.; 179 Queen Victoria Street, London EC4V 4EL (GB).</p>		<p>(81) Designated States: AE, AL, AM, AT, AT (Utility model), AU, AZ, BA, BB, BG, BR, BY, CA, CH, CN, CU, CZ, CZ (Utility model), DE, DE (Utility model), DK, DK (Utility model), EE, EE (Utility model), ES, FI, FI (Utility model), GB, GD, GE, GH, GM, HR, HU, ID, IL, IN, IS, JP, KE, KG, KP, KR, KZ, LC, LK, LR, LS, LT, LU, LV, MD, MG, MK, MN, MW, MX, NO, NZ, PL, PT, RO, RU, SD, SE, SG, SI, SK, SK (Utility model), SL, TJ, TM, TR, TT, UA, UG, US, UZ, VN, YU, ZA, ZW, ARIPO patent (GH, GM, KE, LS, MW, SD, SL, SZ, UG, ZW), Eurasian patent (AM, AZ, BY, KG, KZ, MD, RU, TJ, TM), European patent (AT, BE, CH, CY, DE, DK, ES, FI, FR, GB, GR, IE, IT, LU, MC, NL, PT, SE), OAPI patent (BF, BJ, CF, CG, CI, CM, GA, GN, GW, ML, MR, NE, SN, TD, TG).  Published <i>With international search report.</i>  (88) Date of publication of the international search report: 16 March 2000 (16.03.00)</p>

(54) Title: RADIO CHANNEL QUALITY ESTIMATION



(57) Abstract

An apparatus (1) for estimating the quality of a differential quaternary phase-shift keying digitally modulated radio signal. The signal (2) is input to a differential demodulator (3) in which a sequence of digitally modulated constellation points is differentially demodulated to produce a sequence (4) of demodulated constellation points or symbols of the demodulated signal. The magnitudes of the instantaneous energies of the in-phase and quadrature-phase components of each symbol in the sequence (4) is then determined. This gives the instantaneous value of the scalar energy of each sampled symbol in the digitally modulated signal. The radio channel service quality is estimated by determining the variation of a set of two or more of the symbol energy values, e.g. by considering the variance of the set of values in the scalar amplitude sequence.

**FOR THE PURPOSES OF INFORMATION ONLY**

Codes used to identify States party to the PCT on the front pages of pamphlets publishing international applications under the PCT.

AL	Albania	ES	Spain	LS	Lesotho	SI	Slovenia
AM	Armenia	FI	Finland	LT	Lithuania	SK	Slovakia
AT	Austria	FR	France	LU	Luxembourg	SN	Senegal
AU	Australia	GA	Gabon	LV	Latvia	SZ	Swaziland
AZ	Azerbaijan	GB	United Kingdom	MC	Monaco	TD	Chad
BA	Bosnia and Herzegovina	GE	Georgia	MD	Republic of Moldova	TG	Togo
BB	Barbados	GH	Ghana	MG	Madagascar	TJ	Tajikistan
BE	Belgium	GN	Guinea	MK	The former Yugoslav Republic of Macedonia	TM	Turkmenistan
BF	Burkina Faso	GR	Greece	ML	Mali	TR	Turkey
BG	Bulgaria	HU	Hungary	MN	Mongolia	TT	Trinidad and Tobago
BJ	Benin	IE	Ireland	MR	Mauritania	UA	Ukraine
BR	Brazil	IL	Israel	MW	Malawi	UG	Uganda
BY	Belarus	IS	Iceland	MX	Mexico	US	United States of America
CA	Canada	IT	Italy	NE	Niger	UZ	Uzbekistan
CF	Central African Republic	JP	Japan	NL	Netherlands	VN	Viet Nam
CG	Congo	KE	Kenya	NO	Norway	YU	Yugoslavia
CH	Switzerland	KG	Kyrgyzstan	NZ	New Zealand	ZW	Zimbabwe
CI	Côte d'Ivoire	KP	Democratic People's Republic of Korea	PL	Poland		
CM	Cameroon	KR	Republic of Korea	PT	Portugal		
CN	China	KZ	Kazakstan	RO	Romania		
CU	Cuba	LC	Saint Lucia	RU	Russian Federation		
CZ	Czech Republic	LI	Liechtenstein	SD	Sudan		
DE	Germany	LK	Sri Lanka	SE	Sweden		
DK	Denmark	LR	Liberia	SG	Singapore		
EE	Estonia						

INTERNATIONAL SEARCH REPORT

International Application No

PCT/GB 99/01532

A. CLASSIFICATION OF SUBJECT MATTER  
IPC 6 H04B17/00

According to International Patent Classification (IPC) or to both national classification and IPC

B. FIELDS SEARCHED

Minimum documentation searched (classification system followed by classification symbols)

IPC 6 H04B G10L H04Q H04R

Documentation searched other than minimum documentation to the extent that such documents are included in the fields searched

Electronic data base consulted during the international search (name of data base and, where practical, search terms used)

C. DOCUMENTS CONSIDERED TO BE RELEVANT

Category °	Citation of document, with indication, where appropriate, of the relevant passages	Relevant to claim No.
X	US 5 214 687 A (KAENSAEKOSKI ANTTI ET AL) 25 May 1993 (1993-05-25) column 1, line 41 -column 2, line 57 ---	1,3-12, 14,16-25
X	GB 2 307 375 A (BRITISH BROADCASTING CORP) 21 May 1997 (1997-05-21) claims 2,3 ---	1,2,6, 14,15,19
X	WO 97 41702 A (NOKIA TELECOMMUNICATIONS OY ;PIIRAINEN OLLI (FI)) 6 November 1997 (1997-11-06) abstract page 4, line 20 -page 5, line 27 ---	1,5,14, 18
X	US 4 653 053 A (PELCHAT GUY M ET AL) 24 March 1987 (1987-03-24) column 1, line 35 - line 58 column 4, line 29 - line 36 ---	1,5,14, 18
	-/--	

Further documents are listed in the continuation of box C.

Patent family members are listed in annex.

° Special categories of cited documents :

"A" document defining the general state of the art which is not considered to be of particular relevance

"E" earlier document but published on or after the international filing date

"L" document which may throw doubts on priority claim(s) or which is cited to establish the publication date of another citation or other special reason (as specified)

"O" document referring to an oral disclosure, use, exhibition or other means

"P" document published prior to the international filing date but later than the priority date claimed

"T" later document published after the international filing date or priority date and not in conflict with the application but cited to understand the principle or theory underlying the invention

"X" document of particular relevance; the claimed invention cannot be considered novel or cannot be considered to involve an inventive step when the document is taken alone

"Y" document of particular relevance; the claimed invention cannot be considered to involve an inventive step when the document is combined with one or more other such documents, such combination being obvious to a person skilled in the art.

"&" document member of the same patent family

Date of the actual completion of the international search

17 December 1999

Date of mailing of the international search report

13.01.00

Name and mailing address of the ISA

European Patent Office, P.B. 5818 Patentlaan 2  
NL - 2280 HV Rijswijk  
Tel. (+31-70) 340-2040, Tx. 31 651 epo nl,  
Fax: (+31-70) 340-3016

Authorized officer

Burghardt, G

## INTERNATIONAL SEARCH REPORT

International Application No

PCT/GB 99/01532

C.(Continuation) DOCUMENTS CONSIDERED TO BE RELEVANT		
Category	Citation of document, with indication, where appropriate, of the relevant passages	Relevant to claim No.
Y	WO 94 28638 A (MOTOROLA INC) 8 December 1994 (1994-12-08) abstract; claims 1,9 ---	13,26
Y	US 5 581 651 A (ISHINO TOSHIYUKI ET AL) 3 December 1996 (1996-12-03) column 3, line 56 - line 64 column 4, line 43 - line 65 abstract ---	13,26
A	US 5 710 986 A (WAKABAYASHI NAOYUKI ET AL) 20 January 1998 (1998-01-20) column 4, line 13 - line 34 -----	13,26

# INTERNATIONAL SEARCH REPORT

national application No.

PCT/GB 99/ 01532

## Box I Observations where certain claims were found unsearchable (Continuation of item 1 of first sheet)

This International Search Report has not been established in respect of certain claims under Article 17(2)(a) for the following reasons:

1.  Claims Nos.:  
because they relate to subject matter not required to be searched by this Authority, namely:
  
2.  Claims Nos.:  
because they relate to parts of the International Application that do not comply with the prescribed requirements to such an extent that no meaningful International Search can be carried out, specifically:
  
3.  Claims Nos.:  
because they are dependent claims and are not drafted in accordance with the second and third sentences of Rule 6.4(a).

## Box II Observations where unity of invention is lacking (Continuation of item 2 of first sheet)

This International Searching Authority found multiple inventions in this international application, as follows:

1.  As all required additional search fees were timely paid by the applicant, this International Search Report covers all searchable claims.
  
2.  As all searchable claims could be searched without effort justifying an additional fee, this Authority did not invite payment of any additional fee.
  
3.  As only some of the required additional search fees were timely paid by the applicant, this International Search Report covers only those claims for which fees were paid, specifically claims Nos.:
  
4.  No required additional search fees were timely paid by the applicant. Consequently, this International Search Report is restricted to the invention first mentioned in the claims; it is covered by claims Nos.:

### Remark on Protest

- The additional search fees were accompanied by the applicant's protest.
- No protest accompanied the payment of additional search fees.

**FURTHER INFORMATION CONTINUED FROM PCT/ISA/ 210**

This International Searching Authority found multiple (groups of) inventions in this international application, as follows:

1. Claims: 1-10,11,12,14-23,24,25,27,28

Method and apparatus for estimating the service quality provided by a radio channel on the basis of the variation of a set of two or more of the determined parameter values.

Method and apparatus for estimating the service quality provided by a radio channel on the basis of the difference between an expected instantaneous value of a parameter and the value for a sample of a parameter of a modulated signal on the radio channel.

2. Claims: 13,26

Method and apparatus for controlling the playing of a received speech signal by a mobile radio including the step of/means for estimating the quality of service of a radio channel.

# INTERNATIONAL SEARCH REPORT

Information on patent family members

International Application No

PCT/GB 99/01532

Patent document cited in search report	A	Publication date	Patent family member(s)	Publication date
US 5214687	A	25-05-1993	NONE	
<hr style="border-top: 1px dashed black;"/>				
GB 2307375	A	21-05-1997	NONE	
<hr style="border-top: 1px dashed black;"/>				
WO 9741702	A	06-11-1997	FI 961796 A	27-10-1997
			AU 2571397 A	19-11-1997
			CN 1217128 A	19-05-1999
			EP 0891678 A	20-01-1999
			NO 984938 A	23-10-1998
<hr style="border-top: 1px dashed black;"/>				
US 4653053	A	24-03-1987	NONE	
<hr style="border-top: 1px dashed black;"/>				
WO 9428638	A	08-12-1994	AU 7018594 A	20-12-1994
			CN 1098832 A	15-02-1995
			US 5524279 A	04-06-1996
<hr style="border-top: 1px dashed black;"/>				
US 5581651	A	03-12-1996	JP 7030496 A	31-01-1995
			JP 7123242 B	25-12-1995
<hr style="border-top: 1px dashed black;"/>				
US 5710986	A	20-01-1998	JP 5218955 A	27-08-1993
			JP 5218956 A	27-08-1993
			JP 5218957 A	27-08-1993
			JP 5218958 A	27-08-1993
			US 5564077 A	08-10-1996
<hr style="border-top: 1px dashed black;"/>				