

(No Model.)

2 Sheets—Sheet 1.

J. G. BAKER.

PIPE AND ROD VISE.

No. 348,818.

Patented Sept. 7, 1886.

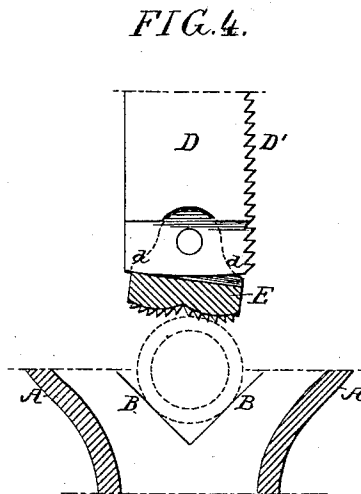
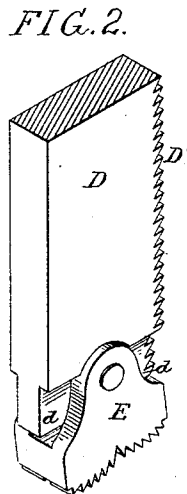
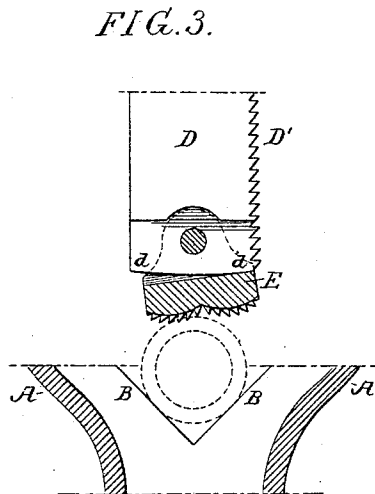
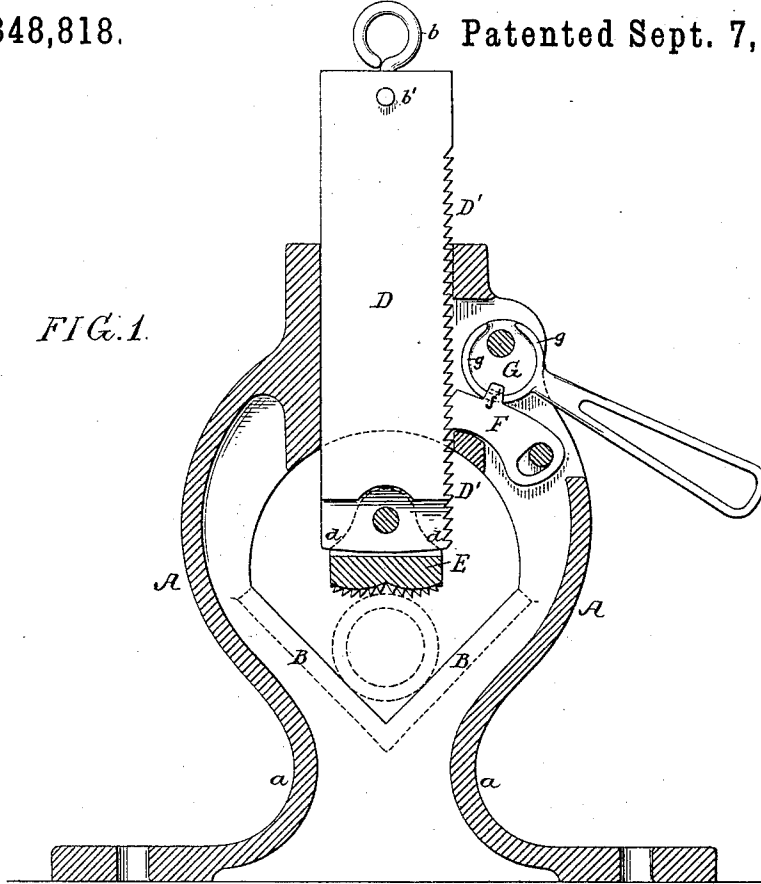

Witnesses:
 Edgar A. Sapperselt
 Williams D. Conner.

Inventor:
 Joseph G. Baker
 by his Attorneys
 Howson and Co.

J. G. BAKER.
PIPE AND ROD VISE.

No. 348,818.

Patented Sept. 7, 1886.

FIG. 5.

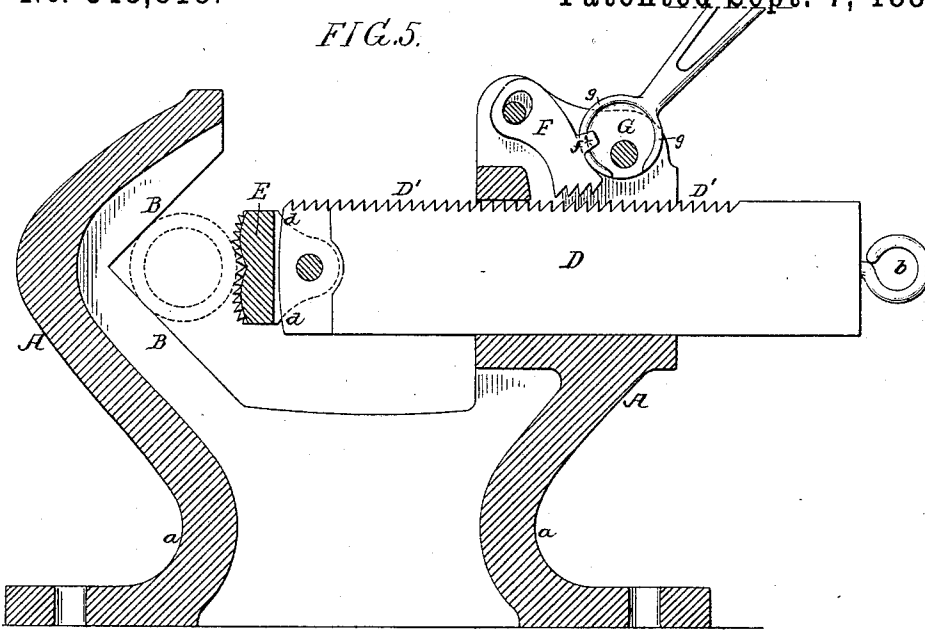

FIG. 6.

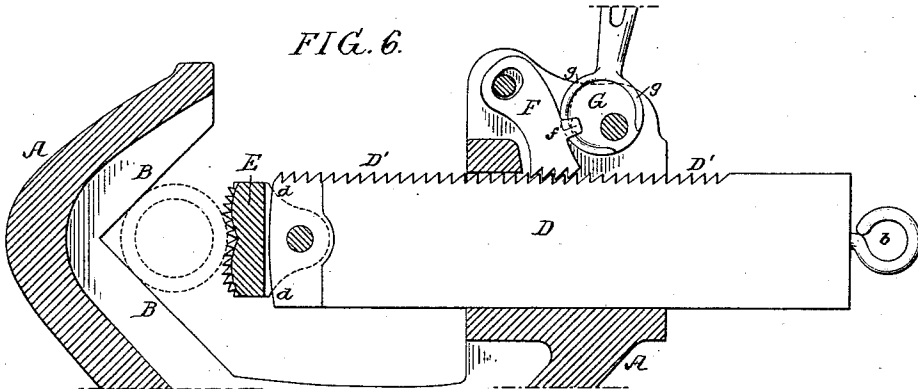
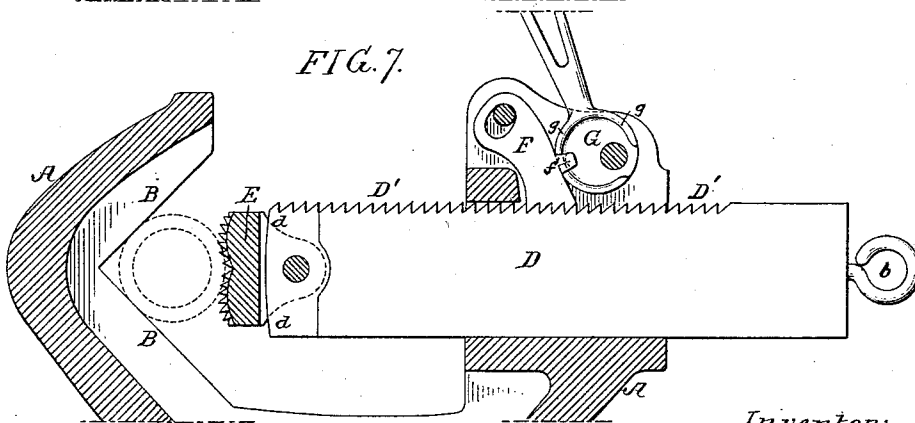

FIG. 7.



Witnesses:
 Edgar A. Hopperett
 William D. Corrier.

Inventor:
 Joseph G. Baker
 by his Attorneys
 Howson and Law

UNITED STATES PATENT OFFICE.

JOSEPH G. BAKER, OF FERNWOOD, PENNSYLVANIA.

PIPE AND ROD VISE.

SPECIFICATION forming part of Letters Patent No. 348,818, dated September 7, 1886.

Application filed May 25, 1886. Serial No. 203,200. (No model.)

To all whom it may concern:

Be it known that I, JOSEPH G. BAKER, a citizen of the United States, residing in Fernwood, Delaware county, Pennsylvania, have invented certain Improvements in Pipe and Rod Vises, of which the following is a specification.

My invention consists of certain improvements in the construction of the pipe and rod vise for which I made application for Letters Patent of the United States March 29, 1886, Serial No. 196,957.

One of the main objects of my present invention is to improve the construction of the devices for locking the movable block carrying the pivoted gripping-jaw, and a further object of my invention is to prevent accidental injury to the pipe from overpressure, while at the same time insuring a good grip on the work. These objects I attain in the manner which I will now proceed to describe.

In the accompanying drawings, Figure 1 is a vertical section of a pipe-vise embodying my improvements. Fig. 2 is a perspective view of the lower end of the gripping-block detached. Figs. 3 and 4 are views illustrating the action of the gripping-jaw carried by the movable block. Fig. 5 is a vertical section of a modified form of vise; and Figs. 6 and 7 are views illustrating the operative devices in different positions.

The frame and general construction of the pipe-vise illustrated in Fig. 1 is similar to that shown in my above-mentioned application, the frame being of a closed-yoke shape, and the movable block carrying the pivoted gripping-jaw being vertical; but in the construction illustrated in Figs. 5, 6, and 7 I have shown a vise having the frame open at one side for the more ready introduction of the pipe or other work to be gripped. In this case I prefer to arrange the sliding block in a horizontal position.

In the construction shown in Figs. 1, 2, 3, and 4 the yoke-shaped body A is mounted vertically on a stem, *a*, with a flattened base for application to the work-bench. On this yoke-shaped body are formed the V-shaped jaws B B of the vise, while the upper part of the frame has a vertical opening for the reception and guidance of the sliding block D, which carries at its lower end the pivoted gripping-

jaw E. At its upper end it is provided with a hook or handle, *b*, for the manipulation of the block when it is desired to raise it to free the pipe or other object from the vise. A stop, *b'*, is formed at the upper end of the block, to prevent it from descending beyond a certain point through the frame.

On one side of the sliding block D are formed ratchet-teeth D', which in my present invention are shown in the reverse position from that illustrated in my former application. With these teeth engages the toothed locking-pawl F, pivoted to the frame and acted upon by a handled cam, G, which is also pivoted to the frame, so that by the action of this cam the pawl may be caused to engage with the ratchet-teeth. The cam G is provided with flanges *g*, engaging with hooks or fingers *f'* on the pawl, so that the latter will always follow the movement of the cam away from the block D, as well as toward it.

In my present invention the form of pawl is changed somewhat from what is shown in my above-described application, and the pivot-point of the pawl is placed behind that of the cam, or, in other words, farther away from the rack than is the cam-pivot, so that when the cam is turned to throw the pawl forward it will have the effect of moving the pawl not only in engagement with the ratchet-teeth thereof, but also downward toward the gripping end of the block, and consequently will tend to push the gripping-jaw into more close contact with the pipe or other article after it has first been brought into contact with the latter, this being insured by making the throw of the cam G greater than one tooth of the ratchet and less than two teeth.

To prevent the pawl from binding on the block, and also to facilitate the disengagement of the teeth of the pawl from the teeth of the ratchet without increasing the extent of movement of the cam, I pivot the pawl loosely to the frame. In the present case I have shown the opening for the pivot-pin larger than the pin. The movements will be those which are more clearly illustrated in Figs. 5, 6, and 7, in which the vise is shown as arranged horizontally and with its frame open at the side. When the cam is moved to withdraw the pawl from contact with the block, the parts will be in the relative positions illustrated in Fig. 5.

If the cam-lever is then moved over to press the pawl into contact with the teeth of the block which has been moved up with its jaw to the pipe, the action will be to first throw the toothed end of the pawl over into engagement with the ratchet-teeth of the block, as indicated in Fig. 6, and then as the movement of the cam is continued the entire pawl will be pushed bodily forward, and with it the block, to force the gripping-jaws into firmer contact with the pipe, as illustrated in Fig. 7.

In my previous application the gripping-jaw E is illustrated as having curved toothed faces eccentric to the pivot, so that when the pipe is turned in either direction by the application of a tool thereto one set of teeth will effectually grip the pipe, but the pull on the pipe may be so great as to cause the continued movement of the pivoted jaw to crush or otherwise injure the pipe. To prevent this accident, therefore, I have brought down the lower ends of the block into such relative positions to the pivoted jaw that these ends will form stops *d*, as illustrated in Figs. 3 and 4, to prevent the pivoted jaw from swinging beyond a certain point, that is, beyond a point

which would cause damage to the pipe or other article acted upon.

I claim as my invention—

1. The combination of the frame and sliding block having ratchet-teeth with a cam pivoted to the frame and a pawl, also pivoted to the frame, but at a point further away from the block than is the cam, substantially as specified.

2. The combination of the frame and sliding block having ratchet-teeth with a pawl loosely pivoted to the frame and a cam to act on the pawl, as set forth.

3. The combination of the frame and sliding block provided with a pivoted gripping-jaw having curved faces and stops *d d* on the block, substantially as and for the purpose set forth.

In testimony whereof I have signed my name to this specification in the presence of two subscribing witnesses.

JOSEPH G. BAKER.

Witnesses:

HUBERT HOWSON,
HARRY SMITH.