

(No Model.)

2 Sheets—Sheet 1.

S. WILLCOCK.  
CHIMING CLOCK.

No. 525,064.

Patented Aug. 28, 1894.

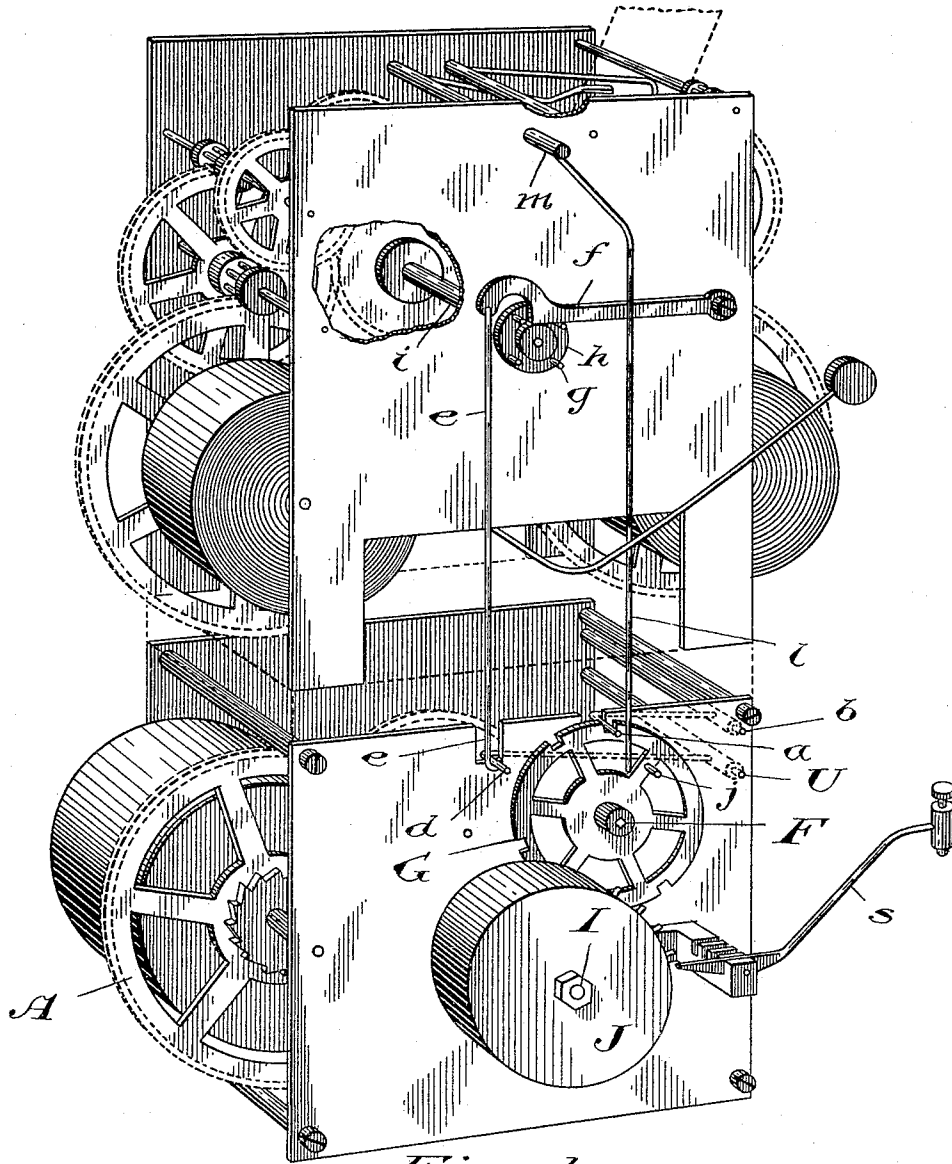

Fig. 1

Witnesses

Fred Clarke  
Thos. E. Robertson

Inventor

Stephen Willcock  
by Rodoubt & Maybee  
Attys

(No Model.)

2 Sheets—Sheet 2.

S. WILLCOCK.  
CHIMING CLOCK.

No. 525,064.

Patented Aug. 28, 1894.

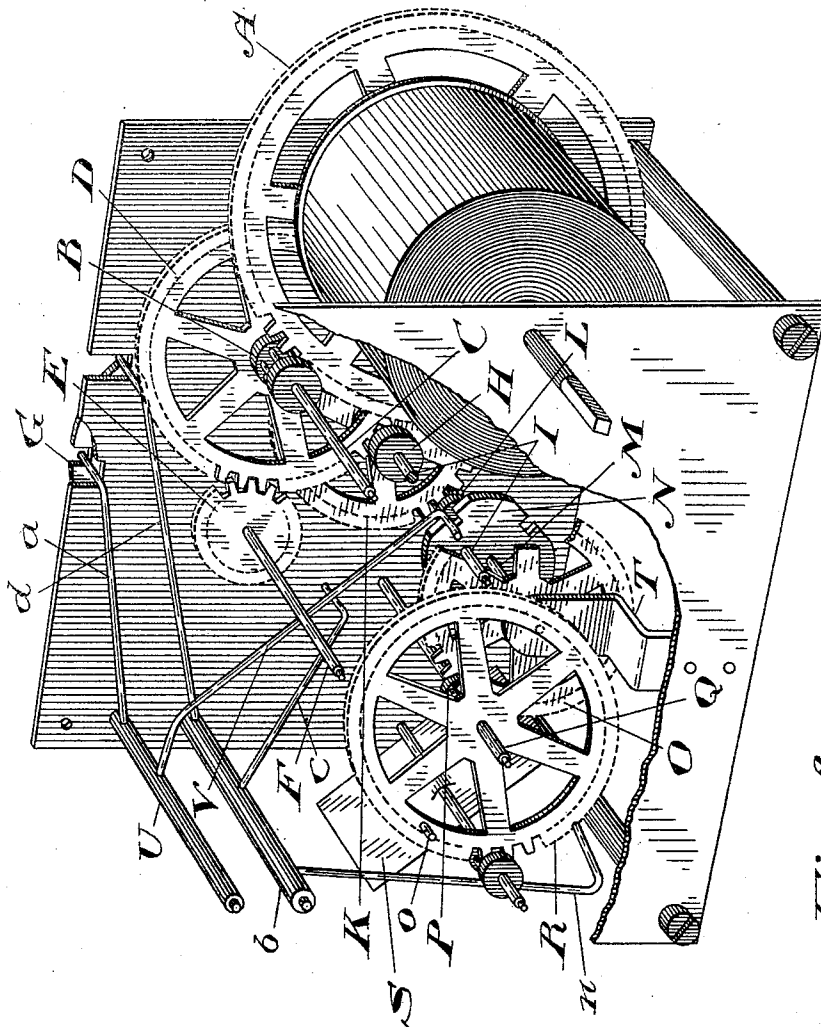

Fig. 2

Witnesses

Fred Clarke  
J. M. Neff

Inventor

Stephen Willcock  
by Ridout & Maybee  
Attys

# UNITED STATES PATENT OFFICE.

STEPHEN WILLCOCK, OF TORONTO, CANADA, ASSIGNOR TO THOMAS SARGANT, OF SAME PLACE.

## CHIMING-CLOCK.

SPECIFICATION forming part of Letters Patent No. 525,064, dated August 28, 1894.

Application filed March 12, 1894. Serial No. 503,345. (No model)

To all whom it may concern:

Be it known that I, STEPHEN WILLCOCK, of the city of Toronto, in the county of York and Province of Ontario, Canada, have invented a certain new and useful Improvement in Chime-Clocks, of which the following is a specification.

The object of this invention is to produce a cheap, simple and efficient chime clock, and it consists, essentially, of a chime movement preferably having an arm attached to its starting spindle, which arm is moved at every quarter hour through the medium of a disk placed on the center arbor of the time movement.

It further consists of a chime movement having a pin placed on one of its wheels, which pin is so arranged as to make one revolution each hour, and which is located in the path of a wire connected with the starting spindle of an ordinary striking movement, so that at the proper time the striking movement is set in motion by the movement of said pin.

My improvement also consists in locating the case of the chime movement substantially in the same plane as the case containing the time and striking movements. By so arranging the cases of these movements, the casing of the chime movement may be made in one piece with the casing of the time and striking movements, or it may be made separate therefrom and be attached to the frame to which the ordinary clock movement is secured, thus needing much less room in the thickness of the clock case.

The invention also consists in the peculiar construction, arrangement and combinations of parts hereinafter more particularly described and then definitely claimed.

In the accompanying drawings, which represent the preferable way of carrying out my invention—Figure 1 is a perspective view showing my chime movement placed below and suitably connected with a time movement and a striking movement. Fig. 2 is a perspective view from the other side of the chime movement.

In showing and describing my invention in detail, it will be unnecessary to describe in detail all of the parts of the time and striking movements, as they form no part of my

present invention, and any of the well-known forms of such movements may be used. It will therefore only be necessary to state that a casing is provided which contains the time and striking movements, and that the letter *i* represents the center arbor of the time movement and the letter *m* represents the starting spindle of the striking movement.

A, is the main driving wheel on the chime movement.

B, is a pinion on the spindle C, with which the main wheel A, meshes.

D, is a spur wheel rigidly connected to the spindle C, and meshing with the pinion E, on the count wheel spindle F. G, is the count wheel which is sprung on to the said spindle, preferably on the outside of the movement, as shown. The spur wheel D, also meshes with the pinion H, on the chime drum spindle I.

J, is the chime drum, which is rigidly connected to this spindle outside the movement, as shown.

K, is a spur wheel rigidly connected to the chime drum spindle I, and meshing with the pinion L, on the locking disk spindle M. The end of the locking disk spindle M, is carried by the bracket T, to give the necessary room for the warning wheel R. To this spindle the locking disk N, is rigidly connected.

O, is a spur wheel rigidly connected to the locking disk spindle M, and meshing with the pinion P, on the warning wheel spindle Q. R, is the warning wheel rigidly connected with this spindle.

S, is the fly driven from the warning wheel, as indicated.

U, is the locking arm spindle, from which projects the locking arm V, having an end adapted to engage with the notches in the locking disk N. An arm *a*, also projects from this spindle and has its end bent to engage with the notches of the count wheel G.

*b*, is a spindle having an arm *c*, which is adapted to engage with the locking arm V. *n*, is an arm attached to this spindle having its end adapted to engage with a pin *o*, on the warning wheel R, when the said spindle *b*, is rocked. From this spindle *b*, another arm *d*, projects, which arm is bent outwardly at its end and engages with a wire *e*, the upper end

of which is pivoted to the rock arm *f*. This arm *f*, is so located as to be alternately raised and dropped by the action of the pins *g*, on the quarter hour disk *h*, which is connected to the center arbor *i*, of the time movement. The rest of this movement is not shown in the drawings, as it may be of any ordinary construction.

*j*, is a pin projecting from the face of the count wheel *G*.

*l*, is a wire rigidly connected to the starting spindle *m*, of the striking movement. The lower end of the wire *l*, lies in the path of the pin *j*, so that at the proper time, the wire *l*, is rocked and the striking movement set in motion. The drum *J*, is of course provided with suitable pins to operate the pivoted bell-hammers *s*, in the usual way. The drum *J*, makes two revolutions while the count wheel *G*, is making one. Thus it takes two complete revolutions of the drum to sound the quarter hour, half hour, three quarter and four quarter hour chimes. As there are thus ten quarter hour chimes sounded, the drum *J*, must be provided with five quarter hour sets of pins.

The operation of my chime clock is as follows:—By the revolution of the center arbor *i*, one of the pins *g*, is caused to raise the pivoted rock arm *f*, which through the wire *e*, and arm *d*, rocks the spindle *b*. The arm *c*, is thus made to lift the locking arm *V*, out of one of the notches in the locking disk *N*, and the arm *a*, is by the movement of the locking arm spindle *b* lifted out of the notch in the count wheel in which it was lying; at the same time the end of the arm *n*, is brought into the path of the pin *o*, on the warning wheel *R*. The train is thus left free to move till the pin *o*, comes in contact with the arm *n*. This motion of the train is sufficient to bring the periphery of the locking disk under the locking arm *V*, preventing the dropping of the locking arm, which prevents the arm *a*, again dropping into the notch in the count wheel *G*, when the spindle *b*, is left free to rock after one of the pins *g*, on the quarter hour disk has passed from under the pivoted rock arm *f*, and allowed it to drop. When the pin on the quarter hour disk has passed from underneath the pivoted rock arm *f*, the arm falls, and thus the spindle *b*, is allowed to rock so that the arm *n*, is removed out of the path of the pin *o*, on the warning wheel and the train revolves till the next notch on the count wheel *G*, comes under the end of the arm *a*. At the same time, one of the notches on the locking disk *N*, is under the end of the locking arm *V*, and the two arms simultaneously fall into their respective notches, and the movement of the train is stopped. The chime drum *J*, has thus been caused to revolve to an extent regulated by the space between two notches on the count wheel *G*, which, in the movement illustrated, are spaced to ring the quarter, half, three quarter and four quarter hour chimes.

The pin *j*, on the count wheel *G*, is so located as to start the striking movement as soon as the chime movement has completed the ringing of the four quarter chime. It will be noticed that the gearing of the train is so proportioned that four notches are required in the locking disk *N*, to insure that a notch on the locking disk shall be below the locking arm, when one of the notches on the count wheel *G*, is beneath the arm *a*.

I am aware that striking movements are made in which the count wheel is geared to an intermediate spindle geared to the main driving wheel, but in such movements, the locking disk is placed on the same spindle as the striking wheel which corresponds with the chime drum and the warning wheel is geared to the striking wheel spindle. Such an arrangement is impossible in a chime movement such as mine, where the chime drum of necessity moves slowly and I have overcome the difficulty by placing the locking disk on an independent spindle geared to the chime drum spindle and gearing the warning wheel spindle to the said locking disk spindle. This arrangement increases the speed of the locking disk and warning wheel and allows the locking arm to engage and disengage from the locking disk and the warning to take place within the time the chime drum is making one-fortieth of a revolution, which is all the space that can be allowed between each set of four chime pins.

From the above description it will be seen that I have succeeded in producing a very cheap, simple and efficient chime clock, and owing to the simplicity and compact nature of the chime movement, it will occupy very little more space than an ordinary time and striking movement.

It will also be seen that, as the casing of the chime mechanism is on substantially the same plane as the casing of the regular clock movement, it may easily be used in connection with any ordinary clock mechanism or be attached to the casing or housing of clocks already manufactured without making the said housing or casing any thicker.

When describing the movements as being on the same plane with each other, I mean that the chime movement is placed in such a position relative to the regular clock movement that the casing of the chime movement (or the front and back plates which constitute said casing) is made in continuation of, or in line with, the casing or front and back plates of the regular clock movement, for when it is so made, the chime movement may be placed either underneath or on the side of the regular movement instead of in front or in back of said movement, and thus will not take up any room in the thickness of the clock; there generally being much superfluous room on the sides of and underneath the clock movement, while that part of the clock immediately back of or in front of the movement is generally taken up by some part of

said movement. It will thus be seen that by making the movements in line with or on the same plane with each other, that much less room is occupied in the thickness of the clock. If the chime movement is not quite as thick as the clock movement, I prefer to place the back plate of the chime movement in line with the back plate of the clock movement; by so doing the rear parts of the movements are on a plane with each other, thus enabling the connections between the movements to be easily made.

What I claim as my invention is—

1. In a chime clock, a chime movement, located substantially in the same plane as a time movement and operated by a wire reciprocated by a disk connected to the center arbor of the time movement, in combination with a striking movement having a wire rigidly connected to its starting spindle, the lower end of which lies in the path of a pin attached to one of the wheels of the chime movement, substantially as and for the purpose specified.

2. In a chime clock, and in combination with the chime-drum, count wheel and lock arms thereof, a rock-arm *f*, a disk *h* connected with the center arbor of the time movement and having pins *g* projecting therefrom arranged to operate said arm *f* at each quarter revolution, and a connection between said rock arm and the chime movement, substantially as described.

3. In a chime clock, a chime drum making two revolutions in the hour; a count wheel making one revolution in the hour, in combination with suitable stopping and starting mechanism operated by an arm adapted to engage with notches in the count wheel; a reciprocating wire operated by a disk connected to the center arbor of a time movement; and a wire rigidly attached to the starting spindle of a striking movement, its lower end lying in the path of a pin on the count wheel, substantially as and for the purpose specified.

4. In a chime clock, a chime drum making two revolutions in the hour and carried by a spindle deriving motion from the main wheel of the movement, a count wheel making one revolution in the hour and carried by an independent spindle also deriving motion from the main wheel; a locking disk carried by a spindle geared to the chime drum spindle; a warning wheel carried by a spindle geared to the locking disk spindle; suitably carried and operated lock arms adapted to engage with the count wheel, locking disk and warning wheel; a wire adapted to raise the said locking arms and operated from a disk connected to the center arbor of a time movement; and a striking movement having a wire rigidly connected to its starting spindle, the lower end of which lies in the path of a pin attached to the above mentioned count wheel, substantially as and for the purpose specified.

5. In a chime clock, the combination of the following elements:—the chime drum *J*, carried by the spindle *I*, revolving twice in the hour and deriving motion from the main wheel *A*; the count wheel *G*, revolving once in the hour and carried by the independent spindle *F*, deriving motion from the main wheel *A*; the locking disk *N* provided with four notches and carried by the spindle *M*, geared to the chime drum spindle *I*; the warning wheel *R*, carried by the spindle *Q*, geared to the locking disk spindle *M*; the pin *o*; the spindle *U*, carrying the lock arm *V*, and arm *a*; the spindle *b*, carrying the arms, *c*, *n*, and *d*; the wire *e*, pivoted rock arm *f*; disk *h*, carrying one or more pins *g*; wire *l*; pin *j*, on the count wheel *G*; and starting spindle *m*, substantially as and for the purpose specified.

6. In a chime clock, a chime drum making two revolutions in the hour and carried by a spindle deriving motion from the main wheel of the movement, in combination with a count wheel making one revolution in the hour and carried by an independent spindle also deriving motion from the main wheel; a locking disk carried by a spindle geared to the chime drum spindle; a warning wheel carried by a spindle geared to the locking disk spindle and suitably carried and operated lock arms adapted to engage with the count wheel locking disk and warning wheel, substantially as and for the purpose specified.

7. In a chime clock, a chime movement comprising the following elements:—the chime drum *J*, carried by the spindle *I*, revolving twice in the hour and deriving motion from the main wheel *A*; the count wheel *G*, revolving once in the hour and carried by the independent spindle *F*, deriving motion from the main wheel *A*; the locking disk provided with four notches and carried by the spindle *M*, geared to the chime drum spindle *I*, the warning wheel *R*, carried by the spindle *Q*, geared to the locking disk spindle *M*; the pin *o*; the spindle *U*, carrying the lock arm *V*, and arm *a*; and the spindle *b*, carrying the arms *c* and *n*, substantially as and for the purpose specified.

8. In a clock and in combination with the time and striking movements thereof, a chime movement, mechanism between said time and chime movements adapted to set said chime movement in operation, and a connection between said chime and striking movements, so arranged that said striking movement is set in motion by the operation of said chime movement, substantially as described.

Toronto, March 9, 1894.

STEPHEN WILLCOCK.

In presence of—

A. M. NEFF,  
FREDK. CLARKE.