

(No Model.)

E. F. A. HEASTINGS.
TROLLEY STAND.

No. 522,057.

Patented June 26, 1894.

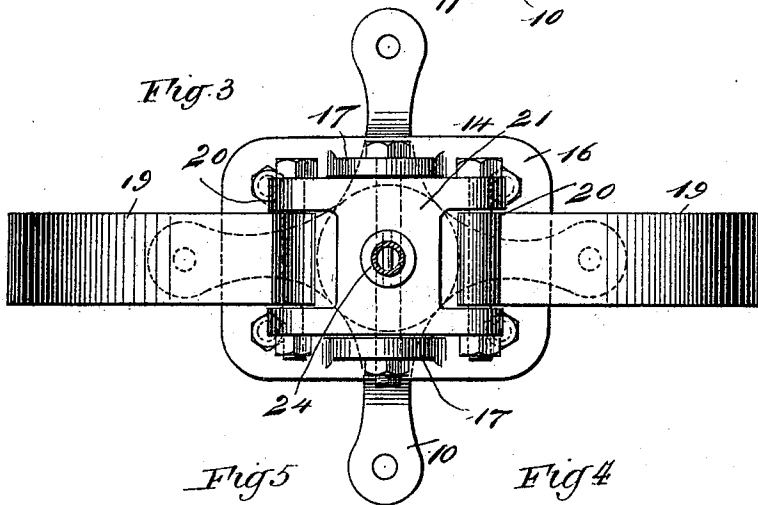
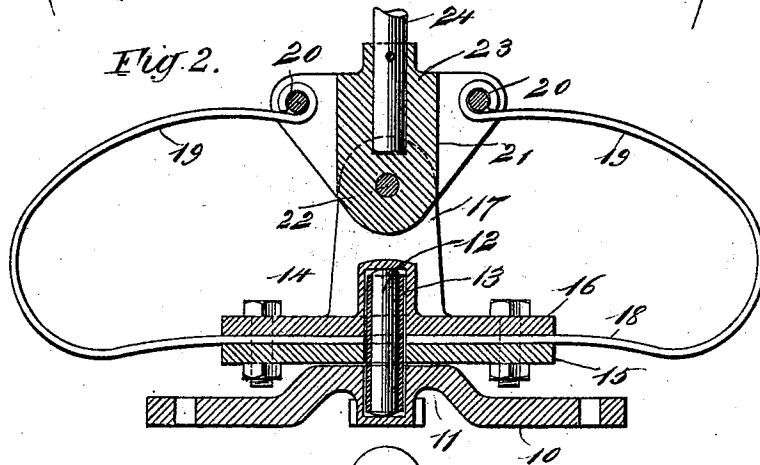
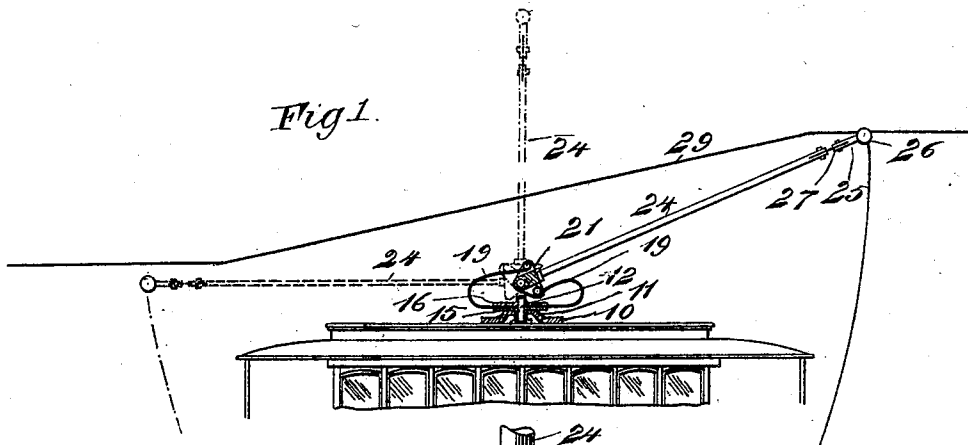
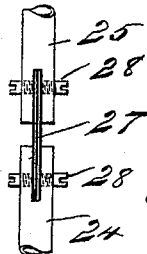
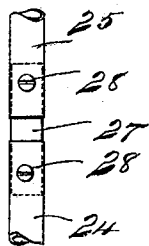

Fig 5

Fig 4



WITNESSES:

Paul Jabot
W. P. Hutchinson

INVENTOR

E. F. A. Hastings
BY *Munn & Co*

ATTORNEYS.

UNITED STATES PATENT OFFICE.

ELEAZER F. A. HEASTINGS, OF AVALON, PENNSYLVANIA.

TROLLEY-STAND.

SPECIFICATION forming part of Letters Patent No. 522,057, dated June 26, 1894.

Application filed April 12, 1894. Serial No. 507,238. (No model.)

To all whom it may concern:

Be it known that I, ELEAZER F. A. HEASTINGS, of Avalon, in the county of Allegheny and State of Pennsylvania, have invented a new and Improved Trolley-Stand, of which the following is a full, clear, and exact description.

My invention relates to improvements in that class of devices which are used in connection with trolley electric railway cars and which are mounted on the car to support the trolley pole.

The object of my invention is to produce a very simple and comparatively inexpensive trolley stand, which may be used in connection with any overhead trolley system, which is adapted to hold the pole in such a way that the trolley wheel always presses firmly against the trolley wire so as to make a good contact, which is so flexible however that the wheel easily follows the wire through its different elevations, as for instance when it is going under a bridge or other obstruction, which has an arrangement of springs adapted to quickly elevate the pole, which is constructed in such a way that in case one end of the spring or one spring breaks, the trolley is not rendered inoperative but will enable the car to be propelled to one end of the line, which may be easily reversed, and which is very easily controlled from the car.

To these ends my invention consists of a trolley stand, the construction of which will be hereinafter described and claimed.

Reference is to be had to the accompanying drawings, forming a part of this specification, in which similar figures of reference indicate corresponding parts in all the views.

Figure 1 is a sectional elevation of the trolley stand, as applied to a pole and car. Fig. 2 is an enlarged detail longitudinal section of the same. Fig. 3 is a sectional plan of the same. Fig. 4 is a broken side elevation of the trolley pole used in connection with the stand; and Fig. 5 is a view, similar to Fig. 4, but taken at right angles to it.

The stand is provided with a suitable base 10, which is adapted to be fastened to the top of the car, as shown in Fig. 1, this base being raised in the center, as shown at 11, to form a suitable support for the bracket above, and it has in the center a socket which receives the

pivot post 12 which is arranged vertically and surrounded by a bushing 13. The base supports the bracket 14 which has a base plate 15 turning on the base, and a top plate 16 bolted to the base plate, the top plate having side lugs 17 which project upward on opposite sides of it, and the bracket formed as described is provided with a central bottom socket to receive the pivot post and bushing on which it turns.

The stand is provided with a flat spring 18 which is clamped between the plates 15 and 16 of the bracket 14, and the ends of which are bent inward and upward, as shown at 19, thus forming two bow springs which, at their upper ends, are pivoted as shown at 20 to a second oscillating bracket 21, this being pivoted at its lower end, as shown at 22, between the lugs 17 of the bracket 14. It will be understood that the bows 19 may be made of independent springs if desired, and that several leaves may be combined if necessary to produce a spring of the desired tension.

In the top of the bracket 21 is a socket 23 to receive the lower section 24 of the trolley pole, and the upper section 25 which carries the trolley wheel 26 is connected to the section 24 of the pole by a spring 27, which is preferably a leaf spring and which is fastened by set screws 28. It will thus be seen that the pole is made flexible as well as its support and that the trolley wheel can easily follow the trolley wire 29, passing over a bend therein, as shown in Fig. 1, with the greatest facility. The spring 27 assists this action and the bow springs 19 serve to quickly return the pole to its place after it has been depressed, one spring pulling and the other pushing, as Fig. 1 shows. If the trolley is to be reversed, the pole may be pulled down and swung around, as illustrated in Fig. 1.

Having thus described my invention, I claim as new and desire to secure by Letters Patent—

1. A trolley stand, comprising a base, a bracket held to turn horizontally thereon, a second pole-carrying bracket pivoted on the first bracket, and bow springs projecting from opposite ends of the first bracket and pivoted to opposite ends of the pole-carrying bracket, substantially as described.

2. A trolley stand, comprising a base adapted

to be secured to a car, a pivot post mounted
in the base, a bracket journaled on the pivot
post and provided with upwardly-extending
arms, a second bracket held in the arms of
5 the first one and adapted to carry a pole, and
bow springs connecting the two brackets, sub-
stantially as described.

3. A trolley stand, comprising a flat topped
base, a bracket journaled on the base to turn
10 horizontally and provided with upwardly-ex-

tending arms, a second bracket pivoted be-
tween the arms of the first bracket and adapt-
ed to carry a trolley pole, and bow springs
clamped to the lower bracket and having their
upper ends pivoted to opposite ends of the 15
second bracket, substantially as described.

ELEAZER F. A. HEASTINGS.

Witnesses:

HENRY R. COPPERSTONE,
FRANK R. OSBORN.