

(No Model.)

H. N. HILL.
SEAM FOR METAL TROUGHS OR TANKS.

No. 525,459.

Patented Sept. 4, 1894.

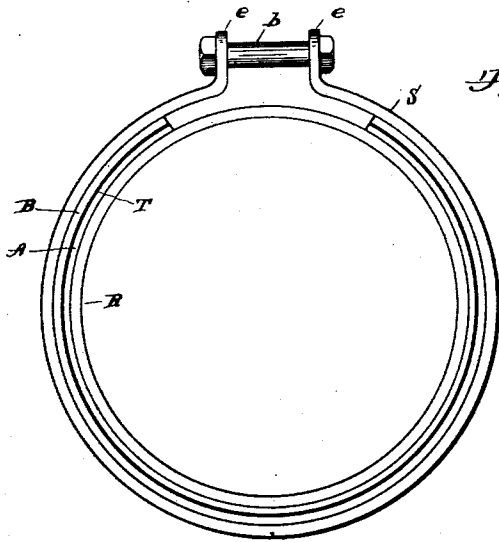

Fig. 2

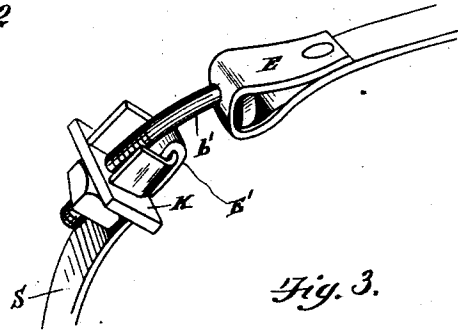

Fig. 3.

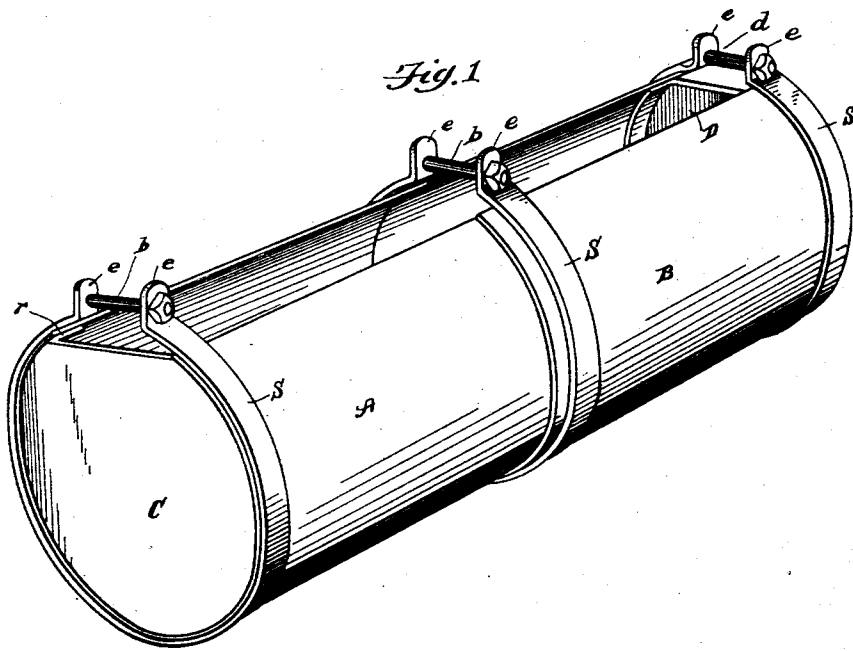

Fig. 1

WITNESSES
J. Clough.
D. W. Bradford

INVENTOR
Harvey N. Hill
By *Parker & Burton*
Attorneys.

UNITED STATES PATENT OFFICE.

HARVEY N. HILL, OF PONTIAC, MICHIGAN, ASSIGNOR OF ONE-HALF TO
MARTIN W. BLOOMBURG, OF SAME PLACE.

SEAM FOR METAL TROUGHS OR TANKS.

SPECIFICATION forming part of Letters Patent No. 525,459, dated September 4, 1894.

Application filed April 16, 1894. Serial No. 507,723. (No model.)

To all whom it may concern:

Be it known that I, HARVEY N. HILL, a citizen of the United States, residing at Pontiac, county of Oakland, State of Michigan, have
5 invented a certain new and useful Improvement in Seams for Metal Troughs or Tanks; and I declare the following to be a full, clear, and exact description of the invention, such
10 as will enable others skilled in the art to which it pertains to make and use the same, reference being had to the accompanying drawings, which form a part of this specification.

This invention relates to water tanks and
15 other similar structures made from sheets or strips of thin metal and used for either holding or conveying liquid.

The especial object of the invention is to produce a joint or seam between two strips
20 of metal, such that it will be impervious to liquid contained in a tank made from such sheets of metal, or flowing through or along a pipe or sluice way made from such sheets of metal.

In the drawings, Figure 1 shows in perspective a tank made from two sheets of metal, and having two heads or end pieces, one at either end. Fig. 2 is a cross section showing the manner of joining the edges or
30 meeting ends of two sheets of metal. Fig. 3 shows a means of drawing together the ends of the external compression ring.

A and B indicate two sheets of metal employed to form a tank. The sheets are rolled
35 into a partially cylindrical form, and the adjacent or joining ends are lapped the one by the other a short distance; and, between the contiguous surfaces of the sheets of metal, I preferably insert a strip of thin cloth, indicated at T in Fig. 2. This thin piece of
40 cloth may be soaked in oil, or may be inserted without such preparation, or it may be entirely omitted, although I prefer to insert it.

On the interior of the tank, within the inside of the under lapping end of the sheet A, is placed a ring R, and on the outside, over the overlapping end of the sheet B, is placed a split ring S. The ends of the split
50 ring S are provided at the extremities with

means for drawing the ends of the ring together and reducing its circumference. The means employed for this purpose may be any of the well known means used for contracting the circumference of the hoop, such as
55 a bolt *b* passing through eyes *ee* in the end of the split ring, or bolt *b'*, one end of which engages with the looped end E of the split ring, and the other end of which engages with a cross bar K that is caught under a loop
60 E' of the end of the split ring. The external hoop or split ring S is arranged directly outside and concentric with the internal ring R, and when the ends of the split ring S are drawn forcibly together by means of the
65 bolt *b*, the two ends of the plates A and B are drawn forcibly and very closely into contact, making a very tight and firm joint without the use of rivets or solder or cement.

To secure the ends C and D in the tank,
70 the ring R may be replaced by an turned flange *r*, which forms a part of the head C; and the sheet of metal A or B, as the case may be, is drawn down tightly; and this flange forms the internal ring, over which
75 the sheet metal is secured, by drawing together the ends of the encircling hoop or split ring in a manner precisely similar to the manner of drawing the two pieces together over the internal ring R. This style of joint
80 can be used in very large tanks, such as are employed in connection with wind mills; and it can also be employed for smaller tanks or troughs, such as are used for the watering of
85 stock. It can also be used in making long sluice ways for conveying water, where the sluice way is nearly level and can be made with an open upper surface.

Tanks or troughs of this form can be very readily and very rapidly constructed, and at
90 very low cost, as there is no necessity of either riveting, cementing, or soldering them.

What I claim is—

1. In a water tank, in combination with an inner support, an outer contractile band,
95 overlapping ends of sheet metal interposed between the support and band, a strip of packing material interposed between contiguous surfaces of the sheet metal forming the tank, substantially as described.

2. In a tank, the combination of an inner supporting member, an outer compression member, overlapping ends of sheet metal interposed between the supporting and compression members, and means for compressing the outer member, substantially as described.

In testimony whereof I sign this specification in the presence of two witnesses.

HARVEY N. HILL.

Witnesses:

ELMER R. WEBSTER,
EMMA WEBSTER.