

(19) World Intellectual Property Organization  
International Bureau



(43) International Publication Date  
23 August 2007 (23.08.2007)

PCT

(10) International Publication Number  
**WO 2007/094725 A1**

- (51) International Patent Classification:  
**B01D 45/14** (2006.01)      **B04B 5/12** (2006.01)  
**B04B 5/08** (2006.01)      **F01M 13/04** (2006.01)
- (21) International Application Number:  
PCT/SE2007/050013
- (22) International Filing Date: 12 January 2007 (12.01.2007)
- (25) Filing Language: Swedish
- (26) Publication Language: English
- (30) Priority Data:  
0600312-3      13 February 2006 (13.02.2006)      SE
- (71) Applicant (for all designated States except US): **ALFA LAVAL CORPORATE AB** [SE/SE]; Box 73, S-221 00 Lund (SE).
- (72) Inventors; and
- (75) Inventors/Applicants (for US only): **BORGSTRÖM, Leonard** [SE/SE]; Rönnbärsvägen 8, S-Tyresö (SE). **CARLSSON, Claes-Göran** [SE/SE]; Gripens Väg 41 A, S-146 36 Tullinge (SE). **SKOOG, Jan** [SE/SE]; Musikalvägen 73, S-142 43 Skogås (SE). **RIDDERSTRÅLE, Rolf** [SE/SE]; Heleneborgsgatan 21 C, S-117 31 Stockholm (SE).

- (74) Agent: **BERGLUND, Stefan**; Bjerkéns Patentbyrå KB, Östermalmsgatan 58, S-114 50 Stockholm (SE).
- (81) Designated States (unless otherwise indicated, for every kind of national protection available): AE, AG, AL, AM, AT, AU, AZ, BA, BB, BG, BR, BW, BY, BZ, CA, CH, CN, CO, CR, CU, CZ, DE, DK, DM, DZ, EC, EE, EG, ES, FI, GB, GD, GE, GH, GM, GT, HN, HR, HU, ID, IL, IN, IS, JP, KE, KG, KM, KN, KP, KR, KZ, LA, LC, LK, LR, LS, LT, LU, LV, LY, MA, MD, MG, MK, MN, MW, MX, MY, MZ, NA, NG, NI, NO, NZ, OM, PG, PH, PL, PT, RO, RS, RU, SC, SD, SE, SG, SK, SL, SM, SV, SY, TJ, TM, TN, TR, TT, TZ, UA, UG, US, UZ, VC, VN, ZA, ZM, ZW.
- (84) Designated States (unless otherwise indicated, for every kind of regional protection available): ARIPO (BW, GH, GM, KE, LS, MW, MZ, NA, SD, SL, SZ, TZ, UG, ZM, ZW), Eurasian (AM, AZ, BY, KG, KZ, MD, RU, TJ, TM), European (AT, BE, BG, CH, CY, CZ, DE, DK, EE, ES, FI, FR, GB, GR, HU, IE, IS, IT, LT, LU, LV, MC, NL, PL, PT, RO, SE, SI, SK, TR), OAPI (BF, BJ, CF, CG, CI, CM, GA, GN, GQ, GW, ML, MR, NE, SN, TD, TG).

Published:  
— with international search report

[Continued on next page]

(54) Title: CENTRIFUGAL SEPARATOR

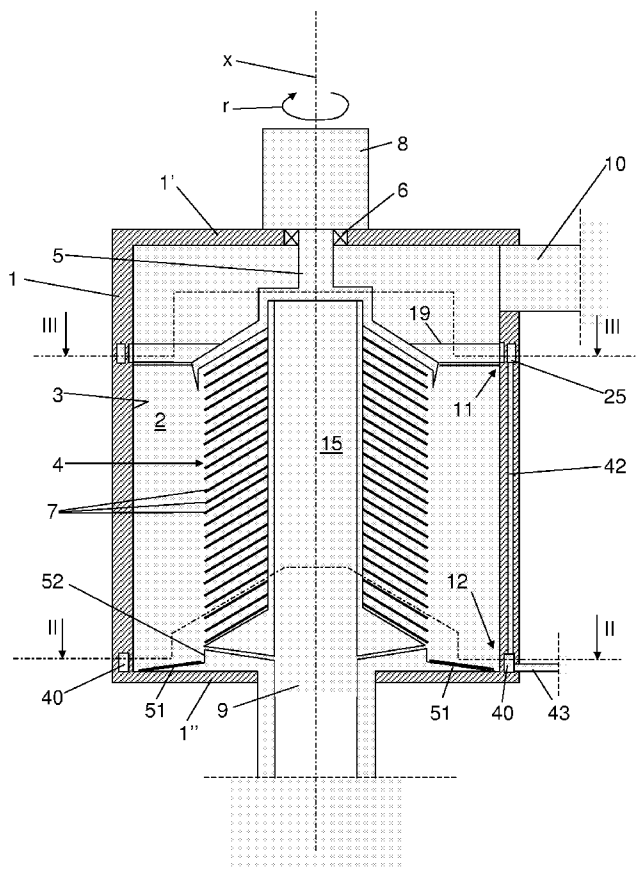

(57) Abstract: The invention refers to a centrifugal separator for cleaning of a gas containing liquid impurities. A stationary casing (1) encloses a separation space (2) and has an inner wall surface (3) facing the separation space. An inlet (9) is provided for the gas to be cleaned. A rotating member (4) is provided in the separation space downstream the inlet and arranged to rotate in a direction (r) of rotation around an axis (x) of rotation. The rotating member brings the gas to rotation in the direction (r) of rotation for separation, by means of centrifugal forces, of liquid impurities from the gas. A gas outlet (10) is provided downstream the rotating member for discharge of the cleaned gas. A first liquid outlet (11) is provided upstream the gas outlet and downstream the rotating member for discharge of separated liquid impurities and comprises at least one outlet hole. A surrounding ring groove (19) extends outwardly from the inner wall surface in the stationary casing and has a surrounding bottom surface (20), wherein the outlet hole extends outwardly from the bottom surface.

WO 2007/094725 A1



---

*For two-letter codes and other abbreviations, refer to the "Guidance Notes on Codes and Abbreviations" appearing at the beginning of each regular issue of the PCT Gazette.*

## 5 Centrifugal separator

### THE BACKGROUND OF THE INVENTION AND PRIOR ART

10 The present invention refers generally to a centrifugal separator for cleaning of gases from liquid impurities, such as oil particles and oil mist. More specifically, the invention refers to a centrifugal separator according to the preamble of claim 1.

15 SE-C-523 690 discloses such a centrifugal separator which is intended for cleaning of a gas containing liquid impurities in the form of oil particles and/or oil mist. The gas outlet for the cleaned gas extends in the known centrifugal separator from a lower part of the separation space. Immediately above the gas outlet, there is a shield element which extends into the separation space. Above the shield element at a distance therefrom, there is a number of outlet holes for discharge of the separated oil from the separation space. The separated oil is caught by the inner wall of the separation space and flows downwardly towards the outlet holes. The technique disclosed in SE-C-523 690 is based on the phenomenon that the shield element will create an annular gas cushion immediately above the shield element, and that this gas cushion will stop up the downwardly flowing oil at the level of the upper end of the gas cushion and at the level of the outlet holes so that the oil may be discharged through the outlet holes.

30 The applicant has found out that a part of the downwardly flowing oil will pass the gas cushion and the shield element, which means that this part of the oil will follow the cleaned gas out from the centrifugal separator through the gas outlet.

35 The outlet holes of the known centrifugal separator are equidistantly located along the periphery of the casing. This means that the oil

that is discharged through the holes has to be collected outside the casing for the transport to a common outlet.

## **SUMMARY OF THE INVENTION**

5

The object of the present invention is to provide a centrifugal separator which in an efficient manner is capable of separating liquid impurities from a gas. Furthermore, it is aimed at a centrifugal separator which has a simple construction and which prevents separated  
10 liquid impurities from being remixed with gas before the gas leaves the centrifugal separator.

This object is achieved by the centrifugal separator initially defined, which is characterized in that it comprises a surrounding ring  
15 groove, which extends outwardly from the inner wall surface in the stationary casing and has a surrounding bottom surface, wherein the outlet hole extends outwardly from the bottom surface.

By means of such a ring groove, which extends outwardly from the  
20 wall surface, i.e. into the wall of the stationary casing, liquid impurities flowing along the inner wall surface will be caught. Liquid impurities move at a relatively high speed in a rotating path along the direction of rotation. The liquid impurities will be collected in the ring groove and flow in the direction of rotation in the ring groove.

25

According to an embodiment of the invention, the first liquid outlet also comprises an annular collecting channel, which extends around the separation space radially outside the ring groove. In such a way, the separated liquid impurities are collected in an easy  
30 and convenient manner and will thereafter be conveyed away from the centrifugal separator by means of one single conduit. Advantageously, the outlet hole may extend between the ring groove and the collecting channel so that the liquid impurities flowing in the direction of rotation in the ring groove in an easy manner can be discharged to the annular collecting channel.  
35

According to a further embodiment of the invention, the ring groove has a first limiting wall, which extends downstream the bottom surface between the bottom surface and the inner wall surface, wherein the outlet hole has an upper point which lies substantially at the level of the first limiting wall. Consequently, it is ensured that all liquid impurities flowing in the ring groove will be discharged through the outlet hole to the annular collecting channel. Advantageously, the first limiting wall may extend substantially in parallel with a radial plane.

According to a further embodiment of the invention, the ring groove has a second limiting wall, which extends upstream the bottom surface between the bottom surface and the inner wall surface. Advantageously, the second limiting wall is inclined in relation to a radial plane.

According to a further embodiment of the invention, the centrifugal separator comprises at least one guide vane, which is provided for guiding the flow of separated liquid impurities through the outlet hole. Advantageously, the guide vane may extend through the outlet hole, wherein the liquid impurities in an efficient manner are conveyed in through the outlet hole and into the annular collecting channel. The guide vane may advantageously extend in at least one direction which is inclined outwardly and forwardly in relation to a tangent to the direction of rotation at the outlet hole.

According to a further embodiment of the invention, the outlet hole has in relation to the direction of rotation a forward limiting surface and a rearward limiting surface, wherein at least one of these limiting surfaces extends in a direction which is inclined outwardly and forwardly in relation to a tangent to the direction of rotation at the outlet hole.

According to a further embodiment of the invention, the centrifugal separator comprises a second liquid outlet, which is provided upstream the first liquid outlet. Advantageously, the second liquid outlet may then form a main outlet and the first liquid outlet a residual

outlet. Such an arrangement ensures a very good separation of substantially all liquid impurities from the gas to be cleaned and a substantially completely clean gas leaving the centrifugal separator via the gas outlet.

5

According to a further embodiment of the invention, the second liquid outlet comprises an annular collecting channel, which extends around the separation space radially outside the inner wall surface. Furthermore, the second liquid outlet may comprise at least one outlet hole which extends between the separation space and the annular collecting channel.

10

According to a further embodiment of the invention, the centrifugal separator is arranged to be provided in such a way that the axis of rotation extends substantially vertically, wherein the stationary casing has an upper end and a lower end and wherein the gas outlet is provided at the upper end. The second liquid outlet may then be provided at the lower end, wherein a main part of the liquid impurities will flow along the inner wall surface down to the second liquid outlet. A probably smaller part of the liquid impurities will due to the upwardly flowing gas flow be transported upwardly along the inner wall surface to the ring groove and the first liquid outlet.

15

20

According to a further embodiment of the invention, the separation space comprises a lower annular end surface, which extends between the rotating member and the inner wall surface, wherein the lower end surface is configured to transport liquid impurities radially outwardly to the second liquid outlet. Furthermore, the centrifugal separator may comprise a number of guide elements provided on the lower end surface and arranged to promote said transport. Said guide elements, seen radially outwardly, are advantageously directed forwardly in the direction of rotation. By means of such inclined or in relation to a radial direction sloping guide elements, the liquid impurities will, thanks to the influence from the gas flow in the separation space, be conveyed outwardly towards a larger diameter and thus to the inner wall surface and the second liquid outlet. Said guide elements may be configured as ribs extending upwardly from

25

30

35

the lower end surface or as grooves extending downwardly from the lower end surface.

5 According to a further embodiment of the invention, the lower end surface is conical and inclined outwardly and downwardly.

According to a further embodiment of the invention, the rotating member comprises a number of separating discs.

10

### **BRIEF DESCRIPTION OF THE DRAWINGS**

The invention is now to be explained more closely through a description of various embodiments disclosed by way of example and with reference to the drawings attached hereto.

15

Fig 1 discloses a vertical section through a centrifugal separator according to the invention.

Fig 2 discloses a cross section along the line II-II in Fig 1.

Fig 3 discloses a cross section along the line III-III in Fig 1.

20

Fig 4 discloses a view from inside the centrifugal separator towards an outlet hole of a liquid outlet of the centrifugal separator in Fig 1.

Fig 5 discloses a section from above through the outlet hole in Fig 4.

25

Fig 6 discloses an axial section through a liquid outlet of the centrifugal separator in Fig 1.

Fig 7 discloses a section through a guide element in the form of a rib of a surface in the centrifugal separator in Fig 1.

Fig 8 discloses a similar section through a guide element in the form of a groove.

30

### **DETAILED DESCRIPTION OF VARIOUS EMBODIMENTS**

35 Fig. 1 discloses a centrifugal separator for cleaning of a gas containing liquid impurities, for instance oil in the form of oil mist or oil particles, and possibly solid particles. The centrifugal separator comprises a stationary casing 1, which encloses a substantially

closed separation space 2. The casing 1 has an inner wall surface 3, which faces the separation space 2. The separation space 2 is arranged to permit the gas to flow therethrough.

5 The centrifugal separator also comprises a rotating member 4 which is provided in the separation space 2 and arranged to rotate in a direction  $r$  of rotation around an axis  $x$  of rotation, which also forms a centre axis through the casing 1. The centrifugal separator is provided in such a way that the axis  $x$  of rotation extends substantially  
10 vertically so that the stationary casing 1 has an upper end 1' and a lower end 1".

The rotating member 4 comprises a spindle member 5, which is journalled in the casing 1 at the upper end 1' by means of a bearing  
15 6, and a number of separating discs 7. In the embodiment disclosed, the separating discs 7 are conical and extend obliquely downwardly and outwardly from the spindle member 5. The invention is also applicable to rotating members having completely radial separating discs or separating discs extending in axial planes from  
20 the spindle member 5. The rotating member 4 is driven by means of a drive member 8, for instance an electrical motor, and is adapted to bring the gas to rotation in the direction  $r$  of rotation for separating, by means of centrifugal forces, the liquid impurities from the  
25 gas.

25 In the embodiment disclosed, the centrifugal separator also comprises an inlet 9 for the gas to be cleaned, a gas outlet 10 for the cleaned gas, a first liquid outlet 11 for the separated liquid impurities and a second liquid outlet 12 for the separated liquid impurities.  
30

30 The inlet 9 is centrally provided and extends through the lower end 1" of the casing 1. The inlet 9 conveys the gas into a central space 15 of the rotating member 4. From this central space 15, the gas is conveyed radially outwardly to the gaps formed between the separating  
35 discs 7. The gas outlet 10 is provided at the upper end 1' of the casing 1 downstream the rotating member 4. The gas leaving the gaps between the separating discs 7 thus rotates at a high ro-

tary speed in the direction  $r$  of rotation and will continue this rotating movement upwardly to the gas outlet 10 where the cleaned gas leaves the separation space 2.

5 The first liquid outlet 11 is provided upstream the gas outlet 10 and downstream the rotating member 4 with respect to the gas flow. The second liquid outlet 12 is provided at the lower end 1'' of the casing 1 and upstream the first liquid outlet 11 with respect to the gas flow. In the embodiment disclosed, the second liquid outlet 12 forms a  
10 main outlet, which is adapted for discharge of a main part of the liquid impurities, and the first liquid outlet 11 a residual outlet, which is adapted for discharge of substantially all residual liquid impurities. It is to be noted that the separated liquid impurities may contain solid particles which are discharged via the liquid outlets 11 and 12.

15 The centrifugal separator comprises a surrounding ring groove 19, which extends outwardly from the inner wall surface 3 and into the wall of the stationary casing 1. The ring groove 19, see Fig 6, has a surrounding bottom surface 20. The bottom surface 20 extends  
20 substantially in parallel with the axis  $x$  of rotation. The ring groove 19 also has a first, upper limiting wall 21, which extends downstream the bottom surface 20 between the bottom surface 20 and the inner wall surface 3. The first limiting wall 21 extends substantially in parallel with a plane being radial in relation to the axis  $x$  of  
25 rotation. The ring groove 19 also has a second, lower limiting wall 22, which extends upstream the bottom surface 20 between the bottom surface 20 and the inner wall surface 3. The second limiting wall 22 is inclined in relation to a radial plane, and more precisely radially outwardly and upwardly from the inner wall surface 3. The  
30 ring groove 19 is in the embodiment disclosed provided immediately below the gas outlet 10 at the level of an upper part of the rotating member 4. More precisely, the ring groove 19 is located at the level of the uppermost separating disc 7 and somewhat above the outlet of the gap formed between the two uppermost separating discs 7.

35 Furthermore, the centrifugal separator comprises an annular collecting channel 25, which extends around the separation space 2

radially outside the ring groove 19 in a peripheral direction. In the embodiment disclosed, the collecting channel 25 extends in the wall of the stationary casing 1 at the level of the ring groove 19.

5 The first liquid outlet 11 comprises at least one outlet hole 26, which extends outwardly from the bottom surface 20 and forms a passage between the ring groove 19 and the collecting channel 25. In the embodiment disclosed, three such outlet holes 26 are provided between the ring groove 19 and the collecting channel 25. It is to be noted that the centrifugal separator may comprise another number than the disclosed three outlet holes 26, for instance 1, 2, 4, 5, 6 or more outlet holes 26. Furthermore, each such outlet hole 26 has in the embodiment disclosed an upper point located below the first limiting wall 21, see Fig 4.

15

Each outlet hole 26 has, in relation to the direction  $r$  of rotation, a forward limiting surface 27 and a rearward limiting surface 28, see Fig 5. At least one of these limiting surfaces 27, 28 extends in a direction, which is inclined outwardly and forwardly in relation to a tangent of the direction  $r$  of rotation at the outlet hole 26 concerned. In the embodiment disclosed, both the forward limiting surface 27 and the rearward limiting surface 28 are inclined in such a direction.

20

Each outlet hole 26 also comprises a guide vane 29, which is provided to guide the flow of the separated liquid impurities through the outlet hole 26. Such a guide vane 29, which is disclosed more closely in Fig 4, extends through the outlet hole 26 and more precisely from an inner end at the level of the inner wall surface 3 to an outer end located in the collecting channel 25. Each guide vane 29 extends at least in one direction, which is inclined outwardly and forwardly in relation to a tangent of the direction  $r$  of rotation at the outlet hole 26. Furthermore, each guide vane 29 has in the embodiment disclosed a first inner part 29', which has a more radial inclination outwardly than a second outer part 29'' of the guide vane 29. It is to be noted that the centrifugal separator also may comprise guide vanes having another configuration and another location for guiding the flow of liquid impurities towards and through the out-

30

35

let holes 26. Especially, the centrifugal separator may comprise one or several guide vanes 30, which are located upstream the outlet hole 26 seen in the direction  $r$  of rotation. The guide vanes 30 are provided on the second inclined limiting wall 22 and are inclined obliquely upwardly in the direction  $r$  of rotation. Furthermore, there may be a guide member 31, which also is located upstream the outlet hole 26, but provided on the bottom surface 20. The guide member 31 extends along the height of the whole bottom surface 20 and is inclined forwardly and downwardly in the direction of rotation. The guide member 31 may be configured as a groove, or as a projecting guide element. The guide member 31 may also be configured in such a way that it merely comprises one limiting surface, which extends inwardly from the bottom wall 20 whereafter the bottom wall 20 very slowly again reaches its peripheral level.

The second liquid outlet 12 also comprises an annular collecting channel 40, which extends around the separation space 2 radially outside the inner wall surface 3. Furthermore, at least one outlet hole 41 is provided so that it extends between the separation space 3 and the collecting channel 40. In the embodiment disclosed, there are two such outlet holes 41, see Fig 2. It is to be noted that the centrifugal separator may comprise another number than the disclosed two outlet holes 41, for instance 1, 3, 4, 5, 6 or more outlet holes 41. The second liquid outlet 12, i.e. the outlet holes 41 are provided at the lower end 1".

As can be seen in Fig 1, the annular collecting channel 25 of the first liquid outlet 11 is connected to the annular collecting channel 40 of the second liquid outlet 12 via at least one connecting channel 42, which in the embodiment disclosed extends substantially in parallel with the axis  $x$  of rotation. It is of course possible to provide more than one such connecting channel 42. From the annular collecting channel 40 also at least one discharge conduit 43 extends for discharge of the separated liquid impurities from the centrifugal separator.

The centrifugal separator also comprises a lower annular end surface 50, which extends between the rotating member 4 and the inner wall surface 3. The lower end surface 50 is configured to transport liquid impurities radially outwardly to the second liquid outlet 12. The lower end surface 50 is in the embodiment disclosed slightly conical and inclined outwardly and downwardly, see Fig 1. It is to be noted, however, that the lower end surface 50 also may be substantially planar or even inclined somewhat outwardly and upwardly.

10

Furthermore, the centrifugal separator comprises a number of guide elements 51, which are provided on the lower end surface 50 and arranged to promote the transport of the liquid impurities outwardly towards the inner wall surface 3 and the outlet holes 41. The guide elements 51 are, seen radially outwardly, directed forwardly in the direction  $r$  of rotation. The guide elements 51 may be straight or, as in the embodiment disclosed, curved. In the embodiment disclosed, the centrifugal separator has six guide elements 51. However, it is to be noted that more or less such guide elements 51 may be provided on the lower end surface 50. The outlet holes 41 adjoin the lower end surface 50, i.e. the outlet holes 41 have a lower end located at the level of the lower end surface at its radially outer periphery.

20

In the embodiment disclosed, the guide elements 51 are configured as ribs, which extend upwardly from the lower end surface 50, see Fig 7. The guide elements 51 may then have a height from the lower end surface 50 that is at least approximately 1 mm. The guide elements 51 may also be configured as grooves extending downwardly from the lower end surface 50, see Fig 8. Also in this case, the guide elements 51 may have a height or a depth of at least approximately 1 mm from the lower end surface 50. In the embodiment disclosed, there is also a small gap at least between the radially outer end of the guide elements 51 and the inner wall surface 3 so that the liquid impurities may flow freely on the lower end surface 50 along the inner wall surface 3 to one of the outlet holes 41.

30

35

Each guide element 51 has a first radially inner end 51' and a second radially outer end 51''. The radially outer end 51'' is located in the proximity of but at a distance from the inner wall surface 3 so that a radially outer passage is formed between the inner wall surface 3 and the radially outer end 51', see Fig 2. The radially inner end 51' is located in the proximity of but at a distance from an annular inner end of the annular surface 50 so that a radially inner passage is formed between the annular inner end and the radially inner end 51' of each guide element, see Fig 2.

10

The centrifugal separator disclosed may for instance be used for cleaning of gas containing oil in the form of oil particles and/or oil mist. The gas to be cleaned may then be conveyed via the inlet 9 to the space 15. Due to the rotation of the rotating member 4, the gas will also be sucked into the gaps between the separating discs 7, wherein oil will be attached to these discs 7 and due to the centrifugal force transported outwardly on the discs 7. The oil then leaves the discs 7 and is thrown against the inner wall surface 3. The oil will then flow downwardly on the inner wall surface 3 to the lower end surface 50 and the second liquid outlet 12 where the oil will flow out through the outlet holes 41 into the collecting channel 40. A part of the oil, which hits the inner wall surface 3, will, due to the upward gas flow from the rotating member to the gas outlet 10, be transported upwardly along the inner wall surface 3. This oil will flow down into the ring groove 19 and be conveyed into the collecting channel 25 via the outlet holes 26. From the collecting channel 25, the separated oil is then transported down to the collecting channel 40. All separated oil is thus transported to this collecting channel 40, and from there out from the centrifugal separator via the discharge conduit 43.

30

The invention is not limited to the embodiments disclosed, but may be varied and modified within the scope of the following claims.

35

## Claims

1. A centrifugal separator for cleaning of a gas containing liquid impurities, wherein the centrifugal separator comprises
- 5 - a stationary casing (1), which encloses a separation space (2) and has an inner wall surface (3) facing the separation space (2), wherein the separation space permits the gas to flow therethrough,
- an inlet (9) for the gas to be cleaned,
- a rotating member (4), which is provided in the separation space
- 10 (2) downstream the inlet (9) with respect to the gas flow and arranged to rotate in a direction (r) of rotation around an axis (x) of rotation, wherein the rotating member (4) is adapted to bring the gas to rotation in the direction (r) of rotation for separation by means of centrifugal forces of at least a part of the liquid impurities
- 15 from the gas,
- a gas outlet (10), which with respect to the gas flow is provided downstream the rotating member (4) for discharge of the cleaned gas, and
- a first liquid outlet (11), which is provided upstream the gas outlet
- 20 (10) and downstream the rotating member (4) for discharge of the liquid impurities, and which comprises at least one outlet hole (26), characterized in that
- the centrifugal separator comprises a surrounding ring groove (19), which extends outwardly from the inner wall surface (3) in the stationary casing (1) and has a surrounding bottom surface (20),
- 25 wherein the outlet hole (26) extends outwardly from the bottom surface (20).
2. A centrifugal separator according to claim 1, characterized in
- 30 that the first liquid outlet (11) also comprises an annular collecting channel (25), which extends around the separation space (2) radially outside the ring groove (19).
3. A centrifugal separator according to claim 2, characterized in
- 35 that the outlet hole (26) extends between the ring groove (19) and the collecting channel (25).

4. A centrifugal separator according to any one of the preceding claims, characterized in that the ring groove (19) has a first limiting wall (21), which extends downstream the bottom surface (20) between the bottom surface (20) and the inner wall surface (3),  
5 wherein the outlet hole (26) has an upper point which lies substantially at the level of the first limiting wall (21).
5. A centrifugal separator according to claim 4, characterized in that the first limiting wall (21) extends substantially in parallel with a  
10 radial plane.
6. A centrifugal separator according to any one of the preceding claims, characterized in that the ring groove (19) has a second limiting wall (22), which extends upstream the bottom surface (20) between the bottom surface (20) and the inner wall surface (3).  
15
7. A centrifugal separator according to claim 6, characterized in that the second limiting wall (22) is inclined in relation to a radial plane.  
20
8. A centrifugal separator according to any one of the preceding claims, characterized in that the centrifugal separator comprises at least one guide vane (29), which is provided to control the flow of the separated liquid impurities through the outlet hole (26).  
25
9. A centrifugal separator according to claim 8, characterized in that the guide vane (29) extends through the outlet hole (26).
10. A centrifugal separator according to any one of claims 8 and  
30 9, characterized in that the guide vane (26) extends in at least one direction, which is inclined outwardly and forwardly in relation to a tangent to the direction ( $r$ ) of rotation at the outlet hole (26).
11. A centrifugal separator according to any one of the preceding  
35 claims, characterized in that the outlet hole (26) in relation to the direction of rotation has a forward limiting surface (27) and a rearward limiting surface (28), wherein at least one of these limiting sur-

faces (27, 28) extends in a direction, which is inclined outwardly and forwardly in relation to a tangent to the direction (r) of rotation at the outlet hole (26).

- 5 12. A centrifugal separator according to any one of the preceding claims, characterized in that the centrifugal separator comprises a second liquid outlet (12) which is provided upstream the first liquid outlet (11).
- 10 13. A centrifugal separator according to claim 12, characterized in that the second liquid outlet (12), forms a main outlet and the first liquid outlet (11) forms a residual outlet.
14. A centrifugal separator according to any one of claims 12 and  
15 13, characterized in that the second liquid outlet (12) comprises an annular collecting channel (40), which extends around the separation space (2) radially outside the inner wall surface (3).
15. A centrifugal separator according to claim 14, characterized in  
20 that the second liquid outlet (12) comprises at least one outlet hole (41) which extends between the separation space (3) and the collecting channel (40).
16. A centrifugal separator according to any one of the preceding  
25 claims, characterized in that the centrifugal separator is arranged to be provided in such a way that the axis (x) of rotation extends substantially vertically, wherein the stationary casing (1) has an upper end (1') and a lower end (1'') and wherein the gas outlet is provided at the upper end (1').
- 30 17. A centrifugal separator according to claims 12 and 16, characterized in that the second liquid outlet (12) is provided at the lower end (1'').
- 35 18. A centrifugal separator according to claim 17, characterized in that the separation space (2) comprises a lower annular end surface (50), which extends between the rotating member (4) and the

inner wall surface (3), wherein the lower end surface (50) is configured to transport liquid impurities radially outwardly to the second liquid outlet (12).

- 5 19. A centrifugal separator according to claim 18, characterized in that the centrifugal separator comprises a number of guide elements (51) provided on the lower end surface (50) and arranged to promote said transport.
- 10 20. A centrifugal separator according to claim 19, characterized in that said guide elements (51) seen radially outwardly are directed forwardly in the direction (r) of rotation.
- 15 21. A centrifugal separator according to any one of claims 19 and 20, characterized in that said guide elements (51) are configured as ribs which extend upwardly from the lower end surface (50).
- 20 22. A centrifugal separator according to any one of claims 19 and 20, characterized in that said guide elements (51) are configured as grooves extending downwardly from the lower end surface (50).
- 25 23. A centrifugal separator according to any one of claims 18 to 23, characterized in that the lower end surface (50) is conical and inclined outwardly and downwardly.
- 30 24. A centrifugal separator according to any one of the preceding claims, characterized in that the rotating member (4) comprises a number of separating discs (7).



Fig 2

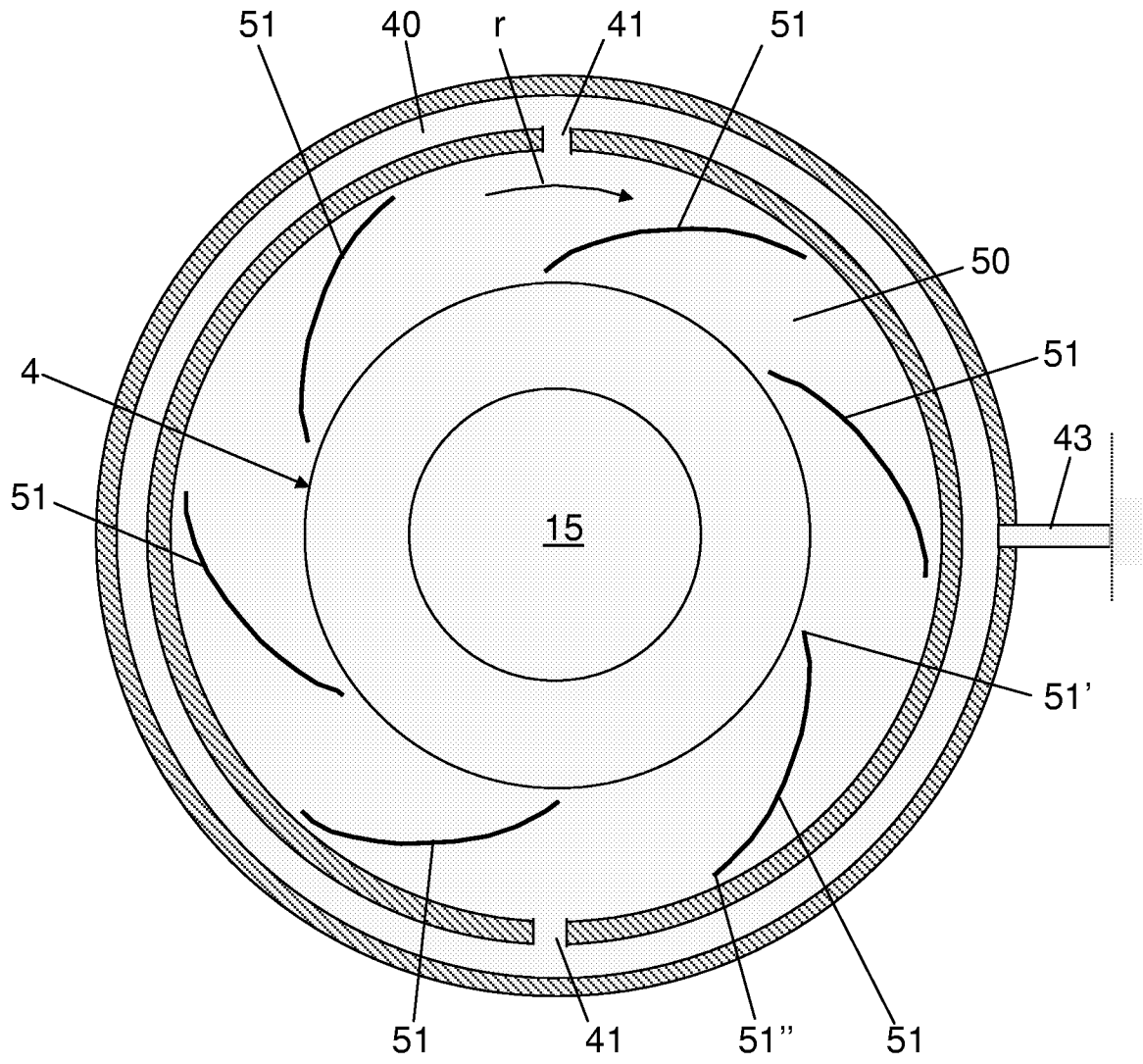

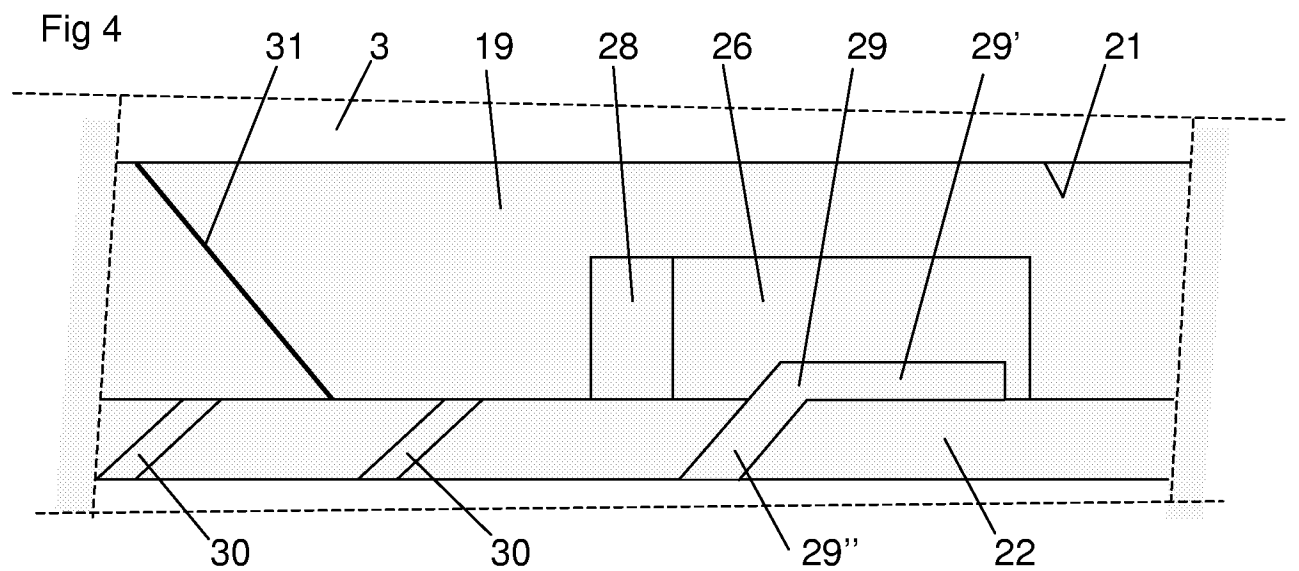
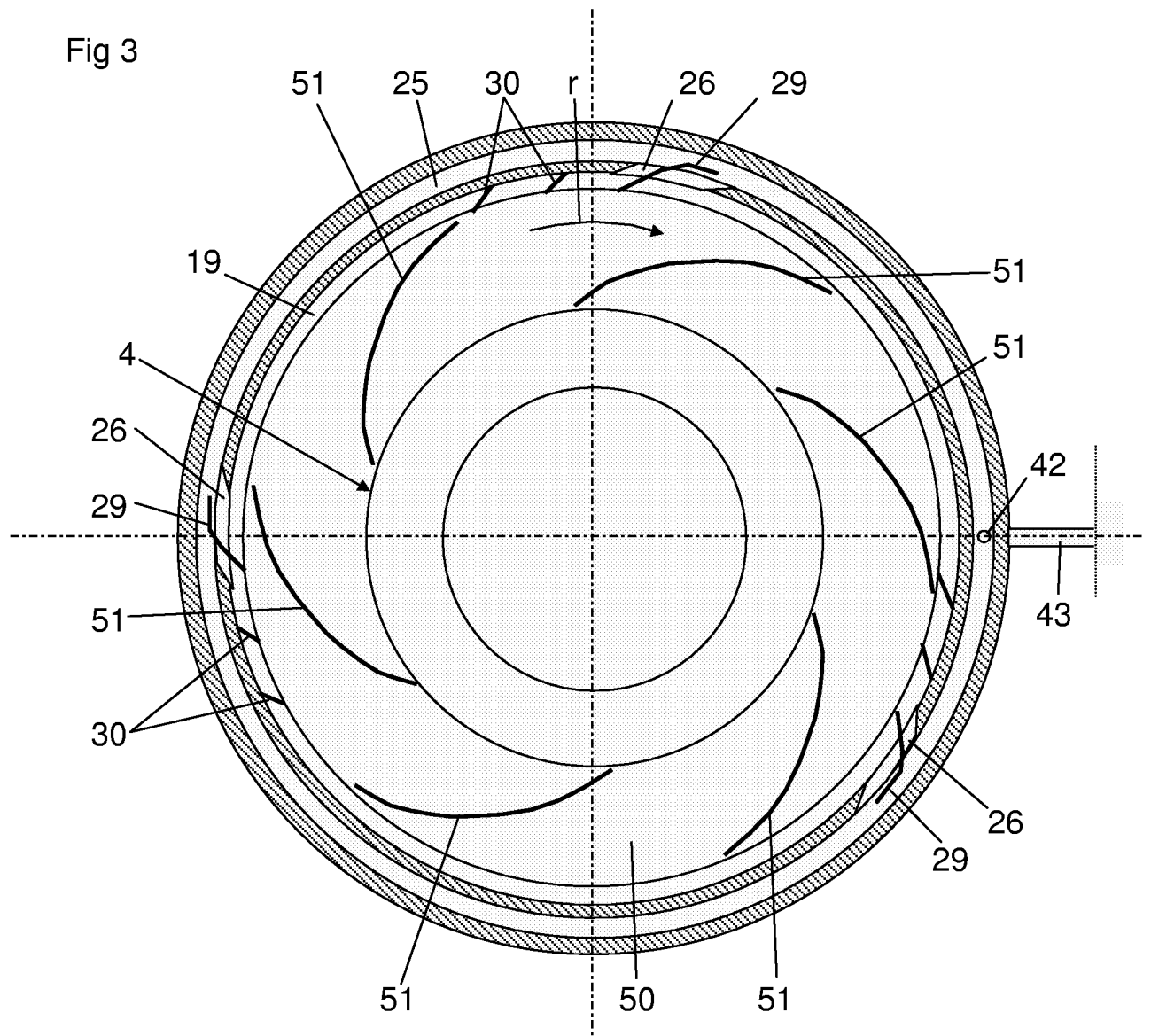

Fig 5

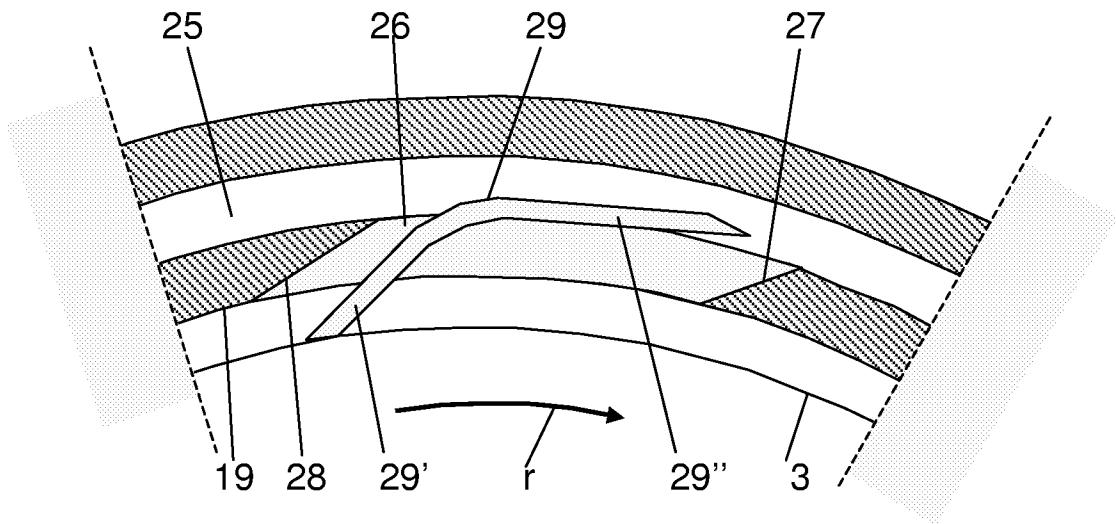
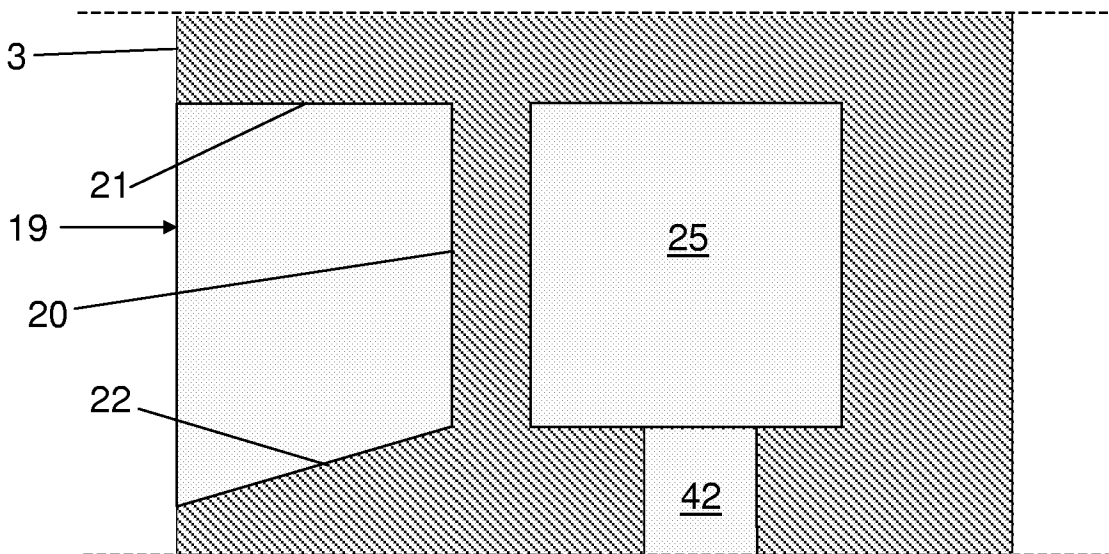

Fig 6



5/5

Fig 7

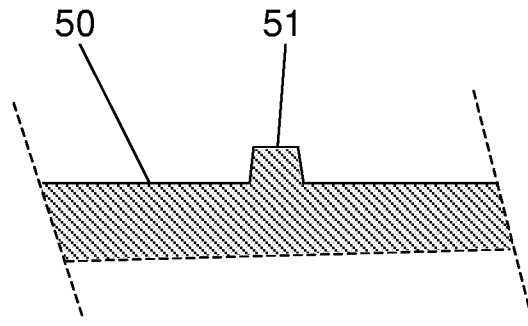
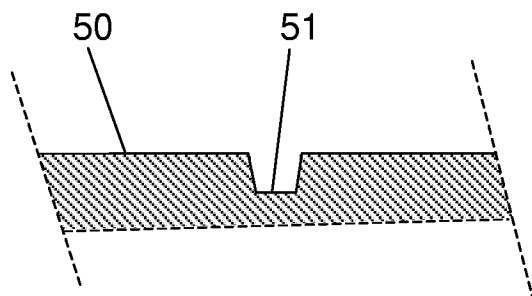

Fig 8



# INTERNATIONAL SEARCH REPORT

International application No.  
PCT/SE2007/050013

## A. CLASSIFICATION OF SUBJECT MATTER

IPC: **see extra sheet**  
According to International Patent Classification (IPC) or to both national classification and IPC

## B. FIELDS SEARCHED

Minimum documentation searched (classification system followed by classification symbols)

IPC: **B01D, B04B, F01M**

Documentation searched other than minimum documentation to the extent that such documents are included in the fields searched

**SE,DK,FI,NO classes as above**

Electronic data base consulted during the international search (name of data base and, where practicable, search terms used)

**EPO-INTERNAL, WPI DATA, PAJ**

## C. DOCUMENTS CONSIDERED TO BE RELEVANT

Category*	Citation of document, with indication, where appropriate, of the relevant passages	Relevant to claim No.
A	SE 505311 C2 (MASCHINENFABRIK KYFFHÄUSERHÜTTE GMBH), 4 August 1997 (04.08.1997), abstract, figures --	1-24
A	WO 2004024927 A1 (3NINE AB), 25 March 2004 (25.03.2004), the whole document --	1-24
A	SE 517760 C2 (ALFA LAVAL AB), 9 July 2002 (09.07.2002), abstract, figures -- -----	1-24

Further documents are listed in the continuation of Box C.  See patent family annex.

* Special categories of cited documents:	"T" later document published after the international filing date or priority date and not in conflict with the application but cited to understand the principle or theory underlying the invention
"A" document defining the general state of the art which is not considered to be of particular relevance	"X" document of particular relevance: the claimed invention cannot be considered novel or cannot be considered to involve an inventive step when the document is taken alone
"E" earlier application or patent but published on or after the international filing date	"Y" document of particular relevance: the claimed invention cannot be considered to involve an inventive step when the document is combined with one or more other such documents, such combination being obvious to a person skilled in the art
"L" document which may throw doubts on priority claim(s) or which is cited to establish the publication date of another citation or other special reason (as specified)	"&" document member of the same patent family
"O" document referring to an oral disclosure, use, exhibition or other means	
"P" document published prior to the international filing date but later than the priority date claimed	

Date of the actual completion of the international search <b>29 May 2007</b>	Date of mailing of the international search report <b>01 -06- 2007</b>
---	---

Name and mailing address of the ISA/ Swedish Patent Office Box 5055, S-102 42 STOCKHOLM Facsimile No. +46 8 666 02 86	Authorized officer  <b>Fredrik Andersson / MRO</b> Telephone No. +46 8 782 25 00
--	---

# INTERNATIONAL SEARCH REPORT

International application No.  
PCT/SE2007/050013

## International patent classification (IPC)

**B01D 45/14** (2006.01)  
**B04B 5/08** (2006.01)  
**B04B 5/12** (2006.01)  
**F01M 13/04** (2006.01)

## Download your patent documents at [www.prv.se](http://www.prv.se)

The cited patent documents can be downloaded at [www.prv.se](http://www.prv.se) by following the links:

- In English/Searches and advisory services/Cited documents (service in English) or
- e-tjänster/anförda dokument (service in Swedish).

Use the application number as username.

The password is **IGYZIIUXPI**.

Paper copies can be ordered at a cost of 50 SEK per copy from PRV InterPat (telephone number 08-782 28 85).

Cited literature, if any, will be enclosed in paper form.

# INTERNATIONAL SEARCH REPORT

Information on patent family members

28/04/2007

International application No.

PCT/SE2007/050013

SE	505311	C2	04/08/1997	DD	287147 A	21/02/1991
				DE	3936165 A	31/05/1990
				DK	550589 A	29/05/1990
				SE	8903942 A	29/05/1990
-----						
WO	2004024927	A1	25/03/2004	AU	2003270152 A	00/00/0000
				EP	1398383 A	17/03/2004
				EP	1539966 A	15/06/2005
-----						
SE	517760	C2	09/07/2002	AU	1445502 A	27/05/2002
				AU	1451602 A	27/05/2002
				EP	1337345 A	27/08/2003
				JP	3888973 B	07/03/2007
				JP	2004513769 T	13/05/2004
				SE	0004162 A	15/05/2002
				US	7001325 B	21/02/2006
				US	20040029698 A	12/02/2004
				WO	0240174 A	23/05/2002
				WO	0240176 A	23/05/2002