

July 4, 1967

R. A. COLA

3,329,962

SOLID STATE ELECTRON TRANSDUCER APPARATUS

Filed June 10, 1963

2 Sheets-Sheet 1

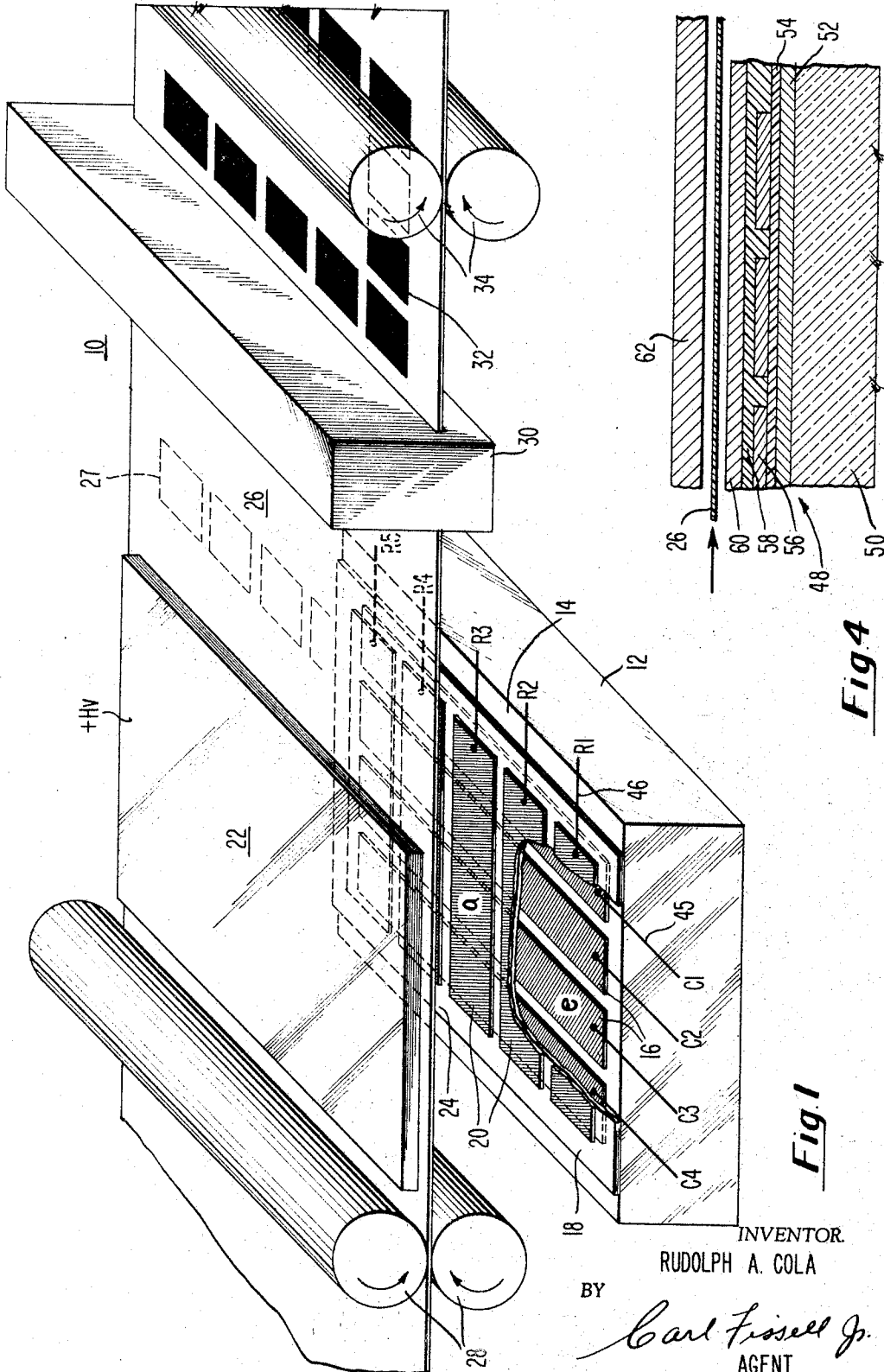

Fig. 4

Fig. 1

INVENTOR
 RUDOLPH A. COLA
 BY *Carl Fissell Jr.*
 AGENT

July 4, 1967

R. A. COLA

3,329,962

SOLID STATE ELECTRON TRANSDUCER APPARATUS

Filed June 10, 1963

2 Sheets-Sheet 2

Fig 2

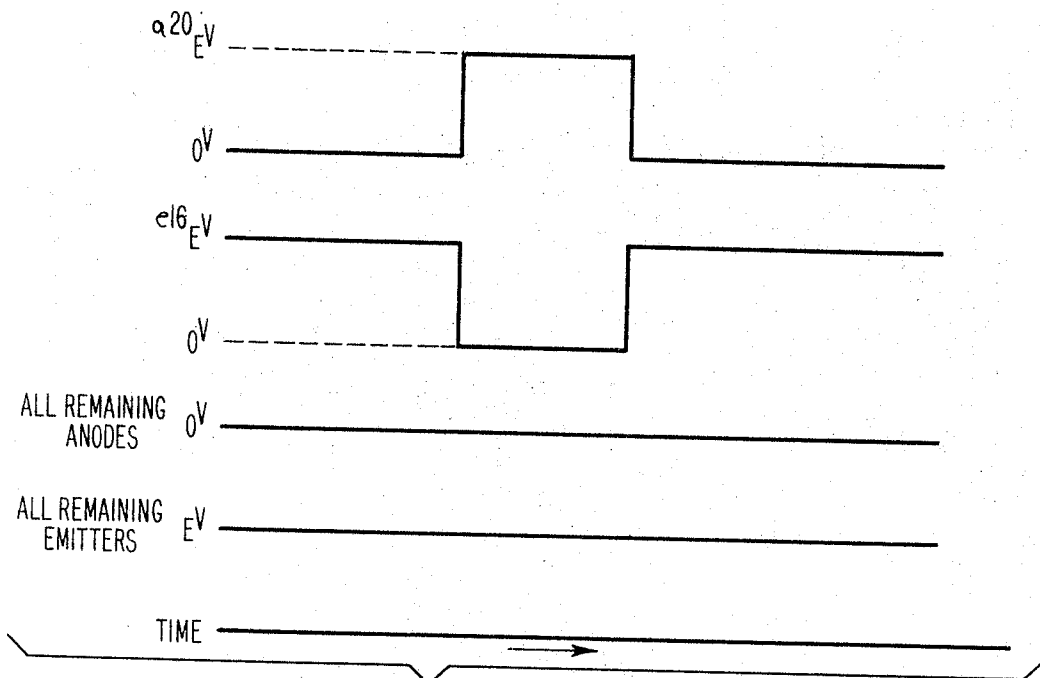
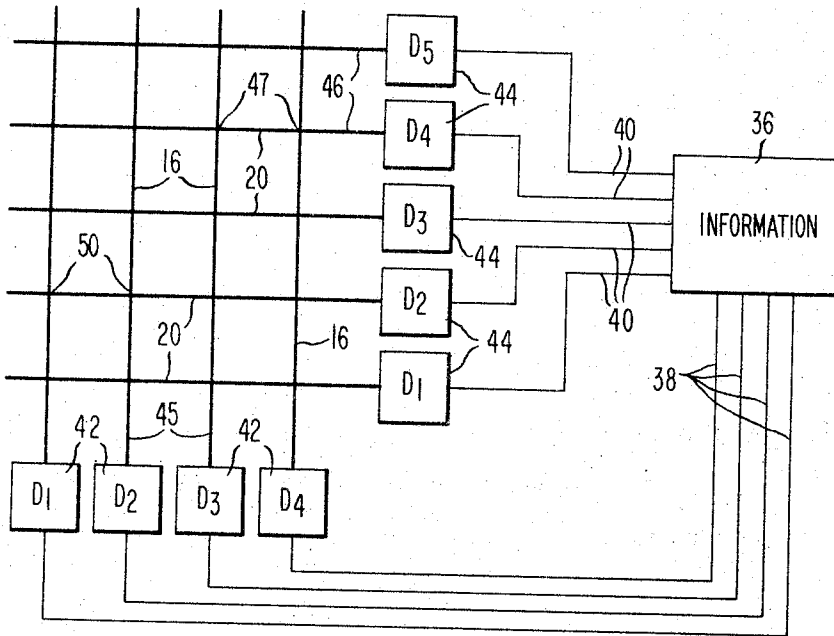

Fig 3

INVENTOR
RUDOLPH A. COLA
BY
Carl Fissel Jr.
AGENT

1

2

3,329,962
**SOLID STATE ELECTRON TRANSDUCER
 APPARATUS**

Rudolph A. Cola, Philadelphia, Pa., assignor to Burroughs Corporation, Detroit, Mich., a corporation of Delaware

Filed June 10, 1963, Ser. No. 286,827
 5 Claims. (Cl. 346-74)

The present invention relates to solid state electron transducer apparatus, and more particularly, although not necessarily exclusively, to solid state electron transducer apparatus utilizing quantum mechanic tunneling effects to generate electrons, e.g., in a beam or ray.

With still more specificity, the invention has to do with transducer apparatus wherein one or more tunnel emissive devices are utilized to produce electron emission into atmospheric air in the vicinity of a record member whereby such member is charged electrically in a manner producing a latent and/or visible image of recorded intelligence thereon.

It is an object of the present invention to provide solid state electron transducer apparatus utilizing quantum mechanic tunnel techniques for applying intelligence to a record member.

Another object of the invention is to provide a solid state electrostatic transducer for producing electron emission into atmospheric air for marking a dielectric record member with intelligence data.

Still another object of the invention is the provision of tunnel triode solid state electron transducer apparatus whereby the electric field in the recording gap is effectively shielded from the selection fields.

In accordance with the foregoing objects and first briefly described, the present invention comprises a solid state electron transducer including an electrically insulating substrate having one or more electrically conductive elements thereon. One or more electrically conductive elements are orthogonally arranged relative to the first conductive elements and electrically insulated therefrom. The relative thicknesses of the conductors and the insulating material being such as to induce electron emission via the quantum mechanic tunneling effect upon the application of a suitable potential to selected conductors. A collecting electrode is disposed adjacent to and in spaced apart relation with respect to the uppermost conductors to provide an air gap into which a record member may be interposed. Application of suitable signal potentials to selected conductive areas causes emitted electrons to impinge upon an associated record member producing charged areas thereon in the form of recorded intelligence.

The foregoing objects, advantages, construction and operation of the present invention will become more readily apparent from the following detailed description, appended claims, and accompanying drawings in which:

FIG. 1 represents an isometric view of the invention as embodied in one form of apparatus;

FIG. 2 is a schematic illustration of an operational control arrangement for the present invention;

FIG. 3 is a set of waveforms illustrative of the applied potentials used with the present invention, and

FIG. 4 is a greatly enlarged cross sectional view of a modification of the transducer construction of the present invention.

The copending application of John G. Simmons, Ser. No. 238,164, filed Nov. 16, 1962, entitled "Solid State Electron Apparatus," now Patent No. 3,275,844, and assigned to the same assignee as the present invention, describes quantum mechanic tunneling devices having current density capabilities that are much larger than known thermal cathodes. Emission from circular areas as small as four mils in diameter has been attained.

When an orderly array of such tunneling devices is fabricated on a planar surface it then becomes possible to resolve emission from any part of the plane down to at least an area of 1.3×10^{-5} in.². As contrasted to this, in electron optics, for example, electron beam resolutions of this order can only be achieved with a relatively high calibre electron gun. Such apparatus is both costly and difficult to fabricate, must be operated in vacuum and is relatively difficult to control in operation.

Altering the environmental conditions from those found in a vacuum to the conditions found in atmospheric air, and with no appreciable change in the emitting surface of the device, it is possible to produce electron emission in atmospheric air. For relatively small gap sizes, i.e., spacing between the anode of the tunneling device and its collector, electrons having a mobility of approximately 10^3 cm./sec./volt, can be collected. Because of the high attachment coefficient of the oxygen molecule O₂ for an electron, negative O₂⁻ ions are produced for larger gaps. These ions have a mobility of approximately 2 cm./sec./volt.

Referring now to FIG. 1, wherein there is depicted a solid state electron transducer 10 embodying the present invention, there is shown a supporting substrate of insulating-dielectric material, such for example, as glass 12. The thickness of the substrate 12 is of no appreciable concern but should be sufficiently thick to provide a suitable support for the operation and handling of the apparatus during subsequent stages of its fabrication and utilization. On one surface 14 of the member 12, there is provided, as for example, by vacuum deposition, one or more electrically conductive members 16, such for example, as metallic aluminum. In the present embodiment, and as will be described more particularly hereinafter, a matrix arrangement has been set forth. However, it is noted that such arrangement is a matter of choice and the actual configuration obviously must suit the particular application. Thus the inventive concept is not to be limited necessarily by the physical configuration. The elements 16 forming the emitter or cathode electrodes *e* of the present invention are or may be vacuum deposited in the form of parallel spaced apart stripes running longitudinally (vertically in FIG. 1) of the glass substrate 12 and forming columns of conductors. Across the surface of the plane formed by the tops of the lower electrodes 16, there is either an insulating member such as the sheet 18, shown in FIG. 1, or the members 16 themselves may be exposed to atmospheric air so that a "grown" self limiting oxide may form thereon. In either case, the insulating layer 18 provides a separation for purposes now to be described.

Over the grown or applied insulating layer 18 there is next deposited one or more conductive members 20, such for example, as strips of metallic aluminum arranged in parallel spaced apart rows and forming anode or collector electrodes *a*. As shown in FIG. 1, the electrodes 20 are orthogonally arranged relative to the first mentioned strips 16, so as beforementioned, to provide e.g., a 4 x 5 matrix of intersecting rows and columns of conductive members. The arrangement hereinabove set forth may be characterized as analogous to an electron tube in that the lowermost conductive members 16 act as cathodes or emitters while the uppermost conductive members 20 act in the nature of anodes or collectors, and, as will be described hereinafter, electron emission into atmospheric air can be accomplished.

Arranged in spaced apart relation to the uppermost conductive members 20 is a collector member 22, also of conductive material, e.g., aluminum, which is disposed with respect to the lower substrate assembly in a manner forming an air gap 24 between the bottom surface of the collecting plate 22 and the uppermost surface of the anode members 20. Into this gap a record member 26 may

be interposed. Such a record member may be in the form of a sheet, or a card, or as shown more particularly in FIG. 1, a thin film of dielectric material such for example, as Mylar, a material manufactured by E. I. du Pont de Nemours Co. of Wilmington, Del.

Since the anode plane, i.e., the plane of the conductors 20, and the collecting plate, i.e., the plane of the collector 22, are parallel, the field between them established by applying suitable potentials to the conductors 16, 20 and 22 is substantially uniform and is perpendicular to such planes. It can thus be seen that the beam of ions or electrons formed by means of this invention will have essentially the same shape as the active emitter area which in the present embodiment is e.g. substantially square. When the record medium 26, with or without a conductive backing material thereon, is placed within the gap, earlier described, one side of which may make contact with the collecting plate 22, and with one of the active emitters *e* emitting electrons, an electrical charge will be deposited on the medium 26 thereby forming a latent, i.e., non-visible image or spot 27. Where the field, due to the parallel planes is much greater than the dipole field created by the charge, very little if any defocusing occurs as the charge is deposited so that the shape of the charged spot necessarily has the same dimensions as the active emitter area.

Provision is made for employing the present transducer in a continuous recording apparatus utilizing a thin, relatively narrow sheet of recording material 26 which is or may be fed from a supply reel not shown, to take-up reel also not shown, by means of a first set of drive rollers 28 positioned on one side of the collecting plate 22 and rotating in the direction of the arrows, as shown, to cause the material 26 to pass into and through the air gap 24 of the transducer 10 and receive electrical charges thereon thereby producing a nonvisible latent electrical charge image. The inker-fixer means 30 may operate in substantially the same manner as that of the apparatus shown and described in Patents 2,955,894 and 3,012,839 in the names of H. Epstein and H. Epstein et al. respectively, and assigned to the present assignee. As the material leaves the inker-fixer 30, the formerly latent image can now be made clearly and plainly visible by the adherence to the charge spots of electrostatically attracted ink particles forming the opaque, i.e., blackened areas 32. Or, in known manner, the image charged spots 27 may be passed before an electrostatic transducer or probe which is capable of deriving a signal from such charged areas. Thereafter the dielectric film 26 is moved rightwardly by means of the rollers 34 rotated in the direction of the arrows, as shown, to a take-up reel, not shown, after which it may be stored or viewed at will.

A selection scheme utilizing the solid state electron transducer of the present invention is shown very generally and schematically in FIG. 2. An information selection mechanism 36 is provided with a plurality of output lines 38 and 40 which feed electrical information to individual drivers 42 and 44 for the vertical and horizontal lines, respectively. Output lines 45 and 46 from each driver terminate at a respective conductive member or strip 16 or 20 forming thereby the earlier mentioned matrix. The vertical drivers are designated D1 through D4, respectively, while the horizontal drivers are designated H1 through H5, respectively. Each driver has information applied thereto in the form of an electrical signal potential from the source of information 36. The voltage required by the tunneling devices of the present apparatus to produce the desired current is relatively small compared to the voltage on the collecting plate 22. Therefore, the fact that the selected anode strip is or may be a few volts more positive than all of the other anodes will not appreciably affect the field within or across the gap 24.

The operation of the present invention may be stated as follows: Consider that all the emitters, cathodes *e* 16

are connected to a source of positive potential, e.g., +6 volts via the drivers 42. All of the collectors, anodes *a* 20 are initially tied to ground-earth potential. A positive high voltage of e.g., 200-300 volts is applied to the plate 22. In the configuration of the apparatus of FIGS. 1 and 2 the interactions of the strips 16 and 20 can be likened to a diode 47 and can be considered as having a reverse potential applied thereto with respect to the collecting plate 2. Since there is no effective current—effective current being defined as sufficient current to cause tunnel electron emission—there will be no electron emission into the gap 24 and no electrical charge image is applied to or formed on the tape 26.

Referring to FIG. 3, application of a positive selection potential (e.g., +6 volts) to select a particular anode strip *a* 20, while simultaneously selectively reducing the potential of cathode emitter strip *e* 16 to zero or ground places a forward potential on the selected diode determined by the intersection of the selective anode and cathode strips 16 and 20. Conduction now occurs. Sufficient current is produced to cause tunnel electron emission into the gap 24. All other anode-cathode combinations but the one selected have a reverse potential of 6 volts or a potential of zero volts thereon. Therefore no effective current flows and these emitting areas e.g., diodes remain unselected. In this manner it is possible to electrically pulse the anode-cathode strip assembly so as to produce a desired pattern of electrical charges upon the tape 26. From what has just been described it is apparent that in order to produce charged areas 27 forming intelligence symbols, for example, the letter U etc. electrical potentials of prescribed amplitude and sign are first applied to the column 1 (C1) conductor 16 over line 45 after which the row 1 through row 5 (R1-R5) conductors 20 are energized over lines 46. The intersections 49 thereby conduct causing electron tunnel emission into the gap 24. The field between the tunnel emitting structure and the collecting plate 22 to which a high positive potential on the order of 100-300 volts has been applied causes the electron beam to impinge upon the web 26 thereby producing charged spots 27 thereon. Suitable inking and fixing of the image results in the formation of visible intelligence, such for example, as the letter U, 32, FIG. 1.

In FIG. 4 there is shown a modified form of the invention wherein a triode type structure 48 is illustrated. An insulating substrate 50 is provided with rows of parallel strips 52 of conductive material, e.g., aluminum, which as before may be evaporatively deposited upon the surface thereof. An insulating layer 54 is next applied to the structure after which an orthogonal layer of rows of conductors 56 are disposed thereon. Insulating material 58 is next laid down over this last layer of conductors 56. Thereafter a common plane electrode 60 is disposed over the uppermost insulating layer 58 and forms a common and continuous anode for all elements of the system thereby completely shielding the field in the printing gap from the selection field. A collecting plate 62 is employed as before and tied to a suitable positive electrical potential e.g., 100-300 volts.

As will be apparent to those skilled in the art from parallel selection and/or printing can be accomplished by providing a separate driver for each conductor line intersection and isolating each intersection or effective diode from its neighbor while employing a common anode plane electrode for example.

It may be desirable in certain applications in which the present invention may find employment to encapsulate portions of the structure so as to prevent damage thereto due to handling, exposure to the atmosphere, etc. It may also be expedient to provide means for enabling the entire structure to be pluggably mounted to the electrical circuitry with which it may be utilized.

What is claimed is:

1. Solid state electron transducer apparatus comprising,
 - (a) an insulating dielectric support member,

5

6

- (b) one or more thin conductive metallic members disposed on said support member in spaced apart parallel relationship,
 - (c) each of said conductive metallic members being provided with an insulating layer overlying the same, 5
 - (d) one or more conductive metallic members disposed orthogonally to said first named conductive members and overlying the insulating layer of said first members,
 - (e) a conductive member superposed with respect to said last named conductive members and arranged in spaced apart relationship thereto forming an air gap therebetween for reception of an associated record medium therethrough, 10
 - (f) means to propel said record member through said air gap, 15
 - (g) means for applying a constant electric potential to said conductive superposed member to provide an electric field in said air gap,
 - (h) means for selecting certain ones of said first and second named conductive metallic members in response to information to be recorded on said record medium, 20
 - (i) means for applying electrical potentials of opposite polarity to said selected ones of said conductive metallic members producing an electric field in the insulating layer disposed between said selected ones of said conductive members, said electric field being effective to cause electron emission into said air gap as a result of quantum mechanic tunneling of said electrons through said conductive and insulating layers whereby a latent electrostatic charge image is formed upon said record medium by said electron emission, and 25 30
 - (j) means to make said latent image visible to the eye. 35
2. Solid state electron transducer apparatus comprising,
- (a) an insulating support member,
 - (b) a plurality of conductive metallic thin film members disposed on said support member in spaced apart parallel relationship, 40
 - (c) each of said conductive members being provided with an insulating oxide layer overlying the same,
 - (d) a plurality of conductive metallic thin film members disposed orthogonally to said first named conductive members and overlying the insulating layer of said first members, 45
 - (e) a flat planar conductive member superposed with respect to said last named conductive members and arranged in spaced apart relationship thereto forming an air gap therebetween for reception of an associated record medium therethrough, 50
 - (f) means for applying a constant electrical potential to said planar conductive member to provide an electric field in said air gap, 55
 - (g) means for selecting certain ones of said first and second named conductive members in response to information to be recorded on an associated record medium, and
 - (h) means for applying electric potentials of opposite polarity to said selected ones of said conductive members producing an electric field in the insulating layer disposed between said selected ones of said conductive members and causing electron emission into said air gap as a result of quantum mechanic tunneling of said electrons through said conductive and insulating layers whereby a latent electrostatic charge image is formed upon said associated record medium by said electron emission. 60 65
3. Solid state electron transducer apparatus comprising, 70
- (a) an insulating support member,
 - (b) one or more vacuum deposited conductive thin film members disposed on said support member in spaced apart parallel relationship, 75

- (c) each of said conductive members being provided with an insulating layer of an oxide of said conductive thin film member overlying the same,
 - (d) one or more vacuum deposited conductive thin film members disposed orthogonally to said first named conductive members and overlying the insulating layer of said first members,
 - (e) a flat planar conductive member superposed with respect to said last mentioned conductive members and arranged in spaced apart relationship thereto forming an air gap therebetween,
 - (f) means for advancing a record medium into and through said air gap,
 - (g) means for applying a constant electric potential to said planar conductive member to provide an electric field in said air gap,
 - (h) means for selecting certain ones of said first and second named conductive thin film members in response to information to be recorded on said record medium,
 - (i) means for applying electrical potentials of opposite polarity to said selected ones of said conductive thin film members producing an electric field in the insulating layer disposed between said selected ones of said conductive members, said electric field being effective to cause electron emission into said air gap as a result of quantum mechanic tunneling of said electrons through said conductive and said insulating layers whereby a latent electrostatic charge image is formed upon said record medium by said electron emission, and
 - (j) means for rendering said latent image visible to the eye.
4. Solid state electron transducer apparatus comprising,
- (a) an insulating substrate,
 - (b) a plurality of conductive thin film members of metallic aluminum disposed on said substrate in spaced apart parallel columns,
 - (c) an insulating layer composed of an oxide of aluminum overlying said conductive members,
 - (d) a plurality of conductive thin film members of metallic aluminum disposed on said insulating layer in spaced apart parallel rows orthogonally to said first named members,
 - (e) a planar metallic collecting member arranged in superposition to said last named conductive members forming an air gap therebetween,
 - (f) means to advance a record member through said air gap in one direction,
 - (g) means for applying a constant electric potential to said planar conductive member to provide an electric field in said air gap,
 - (h) means for selecting certain ones of said first and second named conductive thin film members in response to information to be recorded on said record member,
 - (i) means for applying electrical potentials of opposite polarity to said selected ones of said conductive thin film members producing an electric field in the insulating layer disposed between said selected ones of said conductive members and causing electron emission into said air gap as a result of quantum mechanic tunneling of said electrons through said conductive and insulating layers whereby a latent electrostatic charge image is formed upon said record member by said electron emission, and
 - (j) means for converting said electrostatic latent image into a visible image.
5. Solid state electron transducer apparatus comprising,
- (a) an insulating dielectric substrate,
 - (b) a plurality of conductive vacuum deposited thin film members of metallic aluminum disposed on said substrate in spaced apart parallel columns,

7

- (c) an insulating layer composed of an oxide of said metallic aluminum overlying said conductive members,
- (d) a plurality of conductive vacuum deposited thin film members of metallic aluminum disposed on said insulating layer in spaced apart parallel rows orthogonally to said first named members, 5
- (e) a flat, thin, plate-like planar aluminum collecting member arranged in superposition to said last named conductive members forming an air gap therebetween, 10
- (f) oppositely disposed pairs of roller means effective to advance a record member through said air gap in one direction,
- (g) means for applying a constant electric potential to said planar conductive member to provide an electric field in said air gap, 15
- (h) means for selecting certain ones of said first and second named conductive thin film members in response to information to be recorded on said record member, 20
- (i) means for applying electrical potentials of opposite polarity to said selected ones of said conductive

8

- thin film members providing an electrical field in the insulating layer disposed between said selected ones of said conductive members and causing electron emission into said air gap as a result of quantum mechanic tunneling of said electrons through said conductive and insulating layers whereby a latent electrostatic charge image is formed upon said record member by said electron emission,
- (j) means for converting said electrostatic latent image into a visible image, and
- (k) means for permanently fixing said image.

References Cited

UNITED STATES PATENTS

3,024,140	3/1962	Schmidlin	317—234
3,056,073	9/1962	Mead	317—234
3,068,479	12/1962	Benn et al.	346—74
3,131,256	4/1964	Frohbach	346—74
3,150,282	9/1964	Geppert	317—235

BERNARD KONICK, *Primary Examiner.*J. BREIMAYER, *Assistant Examiner.*