



- (51) International Patent Classification: Not classified
- (21) International Application Number: PCT/IB2015/055882
- (22) International Filing Date: 3 August 2015 (03.08.2015)
- (25) Filing Language: Italian
- (26) Publication Language: English
- (30) Priority Data: RM2014A000448 1 August 2014 (01.08.2014) IT
- (71) Applicant: PIAGGIO & C. S.P.A. [IT/IT]; Viale Rinaldo Piaggio 25, I-56025 Pontedera (IT).
- (72) Inventors: CAPOZZELLA, Paolo; c/o PIAGGIO & C. S.P.A, Viale Rinaldo Piaggio 25, I-56025 Pontedera (IT). BERNARDINI, Roberto; c/o PIAGGIO & C. S.P.A, Viale Rinaldo Piaggio 25, I-56025 Pontedera (IT).
- (74) Agents: LEONE, Mario et al.; C/o Cantaluppi & Partners S.r.l., Viale Della Tecnica 205, I-00144 Rome (IT).
- (81) Designated States (unless otherwise indicated, for every kind of national protection available): AE, AG, AL, AM,

AO, AT, AU, AZ, BA, BB, BG, BH, BN, BR, BW, BY, BZ, CA, CH, CL, CN, CO, CR, CU, CZ, DE, DK, DM, DO, DZ, EC, EE, EG, ES, FI, GB, GD, GE, GH, GM, GT, HN, HR, HU, ID, IL, IN, IR, IS, JP, KE, KG, KN, KP, KR, KZ, LA, LC, LK, LR, LS, LU, LY, MA, MD, ME, MG, MK, MN, MW, MX, MY, MZ, NA, NG, NI, NO, NZ, OM, PA, PE, PG, PH, PL, PT, QA, RO, RS, RU, RW, SA, SC, SD, SE, SG, SK, SL, SM, ST, SV, SY, TH, TJ, TM, TN, TR, TT, TZ, UA, UG, US, UZ, VC, VN, ZA, ZM, ZW.

- (84) Designated States (unless otherwise indicated, for every kind of regional protection available): ARIPO (BW, GH, GM, KE, LR, LS, MW, MZ, NA, RW, SD, SL, ST, SZ, TZ, UG, ZM, ZW), Eurasian (AM, AZ, BY, KG, KZ, RU, TJ, TM), European (AL, AT, BE, BG, CH, CY, CZ, DE, DK, EE, ES, FI, FR, GB, GR, HR, HU, IE, IS, IT, LT, LU, LV, MC, MK, MT, NL, NO, PL, PT, RO, RS, SE, SI, SK, SM, TR), OAPI (BF, BJ, CF, CG, CI, CM, GA, GN, GQ, GW, KM, ML, MR, NE, SN, TD, TG).

**Published:**  
— without international search report and to be republished upon receipt of that report (Rule 48.2(g))

(54) Title: PERMANENT MAGNET ELECTRIC MOTOR AND GENERATOR AND HYBRID MOTOR COMPRISING IT IN A SCOOTER

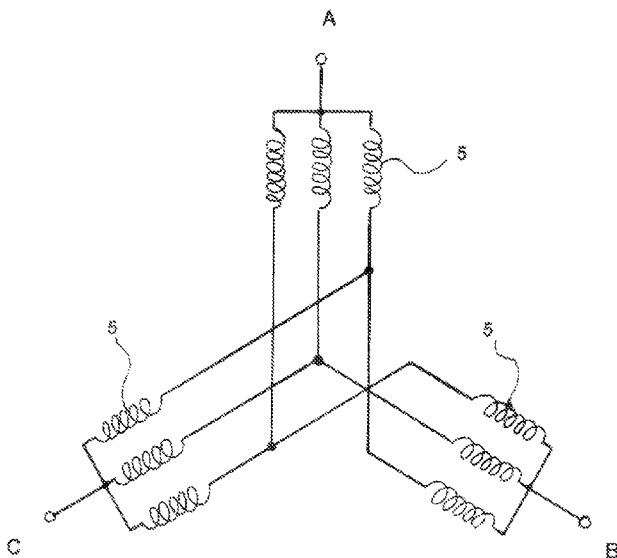

FIG. 2

(57) Abstract: An electric motor-generator (1) of the type with permanent magnets with three-phase radial flow, comprising a stator having a plurality of teeth (3), each one provided with a respective electric winding (5) implemented by a conducting wire and with a respective heading polar expansion (4), divided into groups (A, B, C) corresponding each one to a phase, allows an easy implementation of the windings in the motor itself by using teeth of the stator with even relevant sizes, by obtaining at the same time a reduced short-circuit current which produces a smaller fatigue of the battery during the recharge phase, wherein the electric windings (5) of each single tooth of each group are connected therebetween in parallel, wherein the distance (13) between adjacent polar expansions is the minimum one so as to allow the passage of a conducting wire and wherein, by identifying a first magnetic circuit (X) comprising two adjacent teeth (3), the respective rotor and stator yokes, the thicknesses of the respective permanent magnets and the corresponding air gap, and a second magnetic circuit (Y) comprising two adjacent teeth (3), the respective rotor yokes, the respective halves (12) of the faced polar expansions (4) of said adjacent teeth (5) and the distance (13) between such polar expansions (4), the magnetic reluctances of the first and second circuit (X, Y) have the same order of magnitude.



**PERMANENT MAGNET ELECTRIC MOTOR AND GENERATOR AND HYBRID  
MOTOR COMPRISING IT IN A SCOOTER**

Description

5 The present invention relates to an electric motor, of the type with three-phase permanent magnets (*brushless*), with radial flow, in particular of the type apt to be mounted on the crankshaft of a four-stroke engine to act as motor and generator, thus determining a hybrid motor.

10 In this configuration, which can be used in an advantageous way aboard a scooter with a four-stroke single-cylinder engine, the rotor is provided with a certain number of permanent magnets and it is pre-arranged to be dragged into rotation directly by the crankshaft when the four-stroke engine is operating, to  
15 recharge the vehicle battery.

It is to be noted that this configuration allows recovering a portion of the energy used during breaking, by converting it into electric current.

20 Upon starting the four-stroke engine, the electric motor acts as starter motor fed by the same battery. Advantageously, a system for automatically switching-off the four-stroke engine can be provided when the vehicle stops, with a system managing automatically the engine re-starting as soon as driving power is requested again.

25 In this scheme a stator is used having a substantially circular structure with teeth made of ferromagnetic material, thereon electric wires are wound, crossed by electric current: the teeth are divided into groups for each phase, typically a three-phase solution is used.

30 In the radial flow motor-generator, the selection of the number of teeth and of the type of winding influences the losses inside the electric motor and the amount of short-circuit current, used during the recharging phase, which in turn determines a higher or lower stress in the  
35 battery.

On the other hand, in an engine with small sizes, for example with a displacement of 125 or 150 cc., the rooms available for housing the electric machine are limited,

whereas, indeed for the type of the used motor, the cost thereof has to be low in order not to affect too much that of the scooter including it.

It is to be noted that, at the performance level, the  
5 electric machine has to supply a torque up to 8.0 Nm,  
with a current of about 80 A. Once given these  
constructive constraints, the stator configuration has to  
be optimized to reduce the short-circuit current: a lower  
short-circuit current would allow diminishing the losses  
10 on the electric machine and implementing smaller control  
electronic devices. During the recharging phase a control  
period is established and the control electronic devices  
act during this period: for a period portion by short-  
circuiting the phases of the electric machine and for the  
15 remaining portion by supplying this current to the  
battery.

The European patent Nr. EP 1,344,296 describes a  
particular arrangement of the windings in an electric  
motor wherein a high number of teeth is provided, but  
20 with reduced size. In order to obtain this configuration,  
the winding in each phase groups three teeth connected in  
series.

However, this configuration results to be extremely  
complex, as the reduced size of the teeth makes difficult  
25 the implementation itself of the windings on each tooth.

The International application Nr. WO 00/76054 A1  
describes a stator wherein teeth made of ferromagnetic  
material are provided whereon no winding is provided.  
However, this configuration involves a high number of  
30 teeth.

The Japanese application Nr. JPH03178536 describes an  
arrangement of windings in a stator, wherein the teeth  
are consecutively alternated to belong each one to a  
different phase, with the windings of each phase arranged  
35 in parallel therebetween. However, even this  
configuration is suitable for stators with high number of  
teeth.

The technical problem underlying the present invention is  
to provide an electric motor-generator allowing to

overcome the drawbacks mentioned with reference to the known art.

Such problem is solved by an electric motor-generator of the type with permanent magnets with three-phase radial  
5 flow, comprising a stator, surrounding a rotor, having a plurality of teeth, each one provided with a respective electric winding implemented by a conducting wire and a respective heading polar expansion, divided into groups corresponding each one to a phase, wherein the windings  
10 of each single tooth of each group are connected therebetween in parallel, wherein the distance between adjacent polar expansions is the minimum one so as to allow the passage of a conducting wire and wherein, by identifying a first magnetic circuit comprising two  
15 adjacent teeth, the respective rotor and stator yokes, the thicknesses of the respective permanent magnets and the corresponding air gap, and a second magnetic circuit comprising two adjacent teeth, the respective rotor yokes, the respective halves of the faced polar  
20 expansions of said adjacent teeth and the distance between such polar expansions, the magnetic reluctances of the first and the second circuit have the same order of magnitude.

The main advantage of the electric motor-generator  
25 consists in allowing an easy implementation of the windings in the motor itself by using stator teeth with even important sizes, at the same time by obtaining a reduced short-circuit current producing a smaller fatigue of the battery during the recharge phase.

30 The present invention will be described hereinafter according to a preferred embodiment thereof, provided by way of example and not for limitative purposes by referring to the enclosed drawings wherein:

- 35 \* figure 1 shows a cross-section of the stator of an electric motor according to the present invention;
- \* figure 2 shows a scheme of a winding applied to the stator of figure 1; and
- \* figure 3 represents the magnetic circuits in the winding scheme in figure 2.

By referring to the figures, an electric motor-generator is illustrated in cross-section and it is designated with 1.

5 It is provided in a hybrid motor (not represented) comprising a single-cylinder four-stroke internal combustion engine, wherein the rotor of the electric motor-generator is fitted directly on the crankshaft of the internal combustion engine.

10 In particular, the assembly provides a configuration wherein the electric motor-generator is fitted on the crankshaft on one side of the respective engine block of the internal combustion engine opposite to the one wherein the engine is connected to the vehicle transmission organs, in particular a scooter.

15 The motor-generator is of the type with permanent magnets and has three phases, with a stator, outside the rotor, constituted by nine teeth, divided into groups made up of three teeth for each phase.

20 This type of electric motor is particularly suitable to be mounted on the axis of the crankshaft of a four-stroke engine, in particular a single-cylinder engine, in order to act both as starter engine and as generator.

25 The rotor is implemented in an element full of ferromagnetic material, comprising a central core 2 fitted to the crankshaft of an internal combustion engine: the full portion of the core constitutes the rotor yoke.

30 On the outer surface thereof, the rotor comprises a plurality of (not represented) permanent magnets of the type made of ferromagnetic ceramics, in particular ferrite.

The stator comprises a plurality of teeth 3 extending internally and radially, each one ending outside with an enlarged head 4, also called polar expansion, so as to  
35 implement a compartment between tooth and tooth which is filled up with windings 5 of conducting wire made of copper arranged around each tooth.

The teeth 3 have then an outer connecting surface formed

by the respective heads 4, also called polar expansions which in section have respective projecting halves 12 and they are separated by a distance 13 therethrough the wires have to cross during the winding phase.

5 The stator 1 further comprises a crown or yoke 6 and an outer reinforcement portion thereof, which occupies a circular sector of the stator, therefrom the cables of all windings branch through a connecting element 7 outside the stator 1, then connected inside a sheath 8  
10 and connected to a respective plug 9 which will be connected to the battery.

From said reinforcement portion even other cables branch, connected to Hall sensors, generally phase position sensors, placed between said reinforcement portion 6 and  
15 the teeth 3 positioned therein.

The sheath 8 includes even said other cables, then connected to respective connectors 10 and 11.

As said previously, the teeth 3 are divided into three groups, each one corresponding to a phase: the teeth of  
20 each group are separated by a circular sector of the stator 1, with the width of  $120^\circ$ .

The windings are implemented by a plurality of coils of the same wire made of glazed copper, arranged on several layers on the same tooth.

25 By referring to figure 2, of each group, designated with A, B, C, only the windings 5 of the stator are represented schematically. It is to be noted that the windings 5 of the same group are not arranged in series therebetween, but they are implemented by distinct wire  
30 tracts, connected to the ends in a configuration in parallel.

Therefore, each winding of each tooth belonging to the same group is connected to the windings belonging to the same group in parallel (figure 2).

35 This configuration with nine teeth results then to be particularly advantageous to optimize the engine losses, given a determined design torque requested by the same engine, which determines the weight of the ferromagnetic

material and then the sizes of the engine itself.

Generally, this technique to implement the windings allows using teeth with larger sizes than the state of art, by making then easier to perform the windings during  
5 the assembly of the engine.

By referring to figure 3 the magnetic circuits X, Y are represented, which can be detected for each coil wound on a tooth. A first dotted circuit (figure 3) comprises the tooth 3 of the winding 5, the teeth 3 of the adjacent  
10 windings, the rotor and stator yokes, the thicknesses of the magnets, the air gap. The magnet has a magnetic permeability practically equal to that of the air; it follows that in this circuit there are the higher magnetic losses in the flow passage on the air gap and on  
15 the thickness of the magnets.

The second circuit Y drawn with a solid line, instead, comprises the tooth of the winding, the teeth of the adjacent windings, the rotor yokes, half of the polar expansion and the thickness between the polar expansions.  
20 Here, there are the higher magnetic losses in the flow passage on the thickness between the polar expansions: in order to increase the magnetic reluctance, one has to decrease the losses on the magnetic circuits.

The size of the magnets' thickness is relevant with respect to the air gap and however it can be compared to the distance between the polar expansions, as the thickness is useful to avoid that the magnets made of ferrite could demagnetize when in the machine windings the maximum current circulates. It follows that the  
25 magnetic reluctance of the other circuit (not dotted, solid line) has the same order of magnitude as the one described previously.  
30

Such magnetic circuits are in parallel therebetween: to increase the magnetic reluctance it is sufficient to  
35 decrease the magnetic losses on one of the two circuits.

The first circuit is sized to guarantee the torque performances of the electric machine and then carrying out modifications reducing the magnetic losses and not worsening the performances becomes difficult.

As far as the second circuit is concerned, in order to decrease the magnetic losses it is sufficient to decrease the distance between the polar expansions. The obtainable minimum distance, however, has to be sufficient to allow  
5 the wire passage during the phase for winding the coil on the tooth.

With respect to a solution with a higher number of teeth, for example eighteen, the circuits between two stator poles are connected in series and then the thickness  
10 between the teeth on the second circuit has a double weight, by involving an increase in the losses on the magnets and a decrease in the equivalent reluctance.

Then, substantially a lower reluctance, that is a higher inductance and then a lower short-circuit electric  
15 current, corresponds to a larger size of the tooth, so as to reduce considerably the stress on the battery.

It is to be meant that the herein described solution is only one of the solutions, which is possible to implement according to the same inventive principle.

20 To the above-described electric motor and related electric winding a person skilled in the art, with the purpose of satisfying additional and contingent needs, could introduce several additional modifications and variants, all however comprised within the protection  
25 scope of the present invention, as defined by the enclosed claims.



CLAIMS

1. An electric motor-generator (1) of the type with permanent magnets with three-phase radial flow, comprising a substantially circular stator, surrounding a rotor, having a plurality of teeth (3) radially extending towards the rotor, each one provided with a respective electric winding (5) implemented by a conducting wire and a respective heading polar expansion (4), divided into groups (A, B, C) corresponding each one to a phase, wherein the electric windings (5) of each single tooth of each group are connected therebetween in parallel, wherein the distance (13) between adjacent polar expansions is the minimum one so as to allow the passage of a conducting wire and wherein, by identifying a first magnetic circuit (X) comprising two adjacent teeth (3), the respective rotor and stator yokes, the thicknesses of the respective permanent magnets and the corresponding air gap, and a second magnetic circuit (Y) comprising two adjacent teeth (3), the respective yokes of the rotor (2), the respective halves (12) of the faced polar expansions (4) of said adjacent teeth (5) and the distance (13) between such polar expansions (4), the magnetic reluctances of the first and second circuit (X, Y) have the same order of magnitude.
2. The electric motor according to claim 1, wherein the stator comprises nine teeth, divided into three groups (A, B, C) made up of three teeth each one.
3. A hybrid motor comprising a four-stroke single-cylinder internal combustion engine which has an engine block and a crankshaft crossing it and which, on a side of the engine block, is connected to respective transmission organs, characterized in that it comprises an electric motor-generator of the preceding claims wherein the electric motor-generator is fitted on the crankshaft on the opposite side with respect to that of the transmission organs.
4. A scooter comprising a hybrid motor of claim 3.

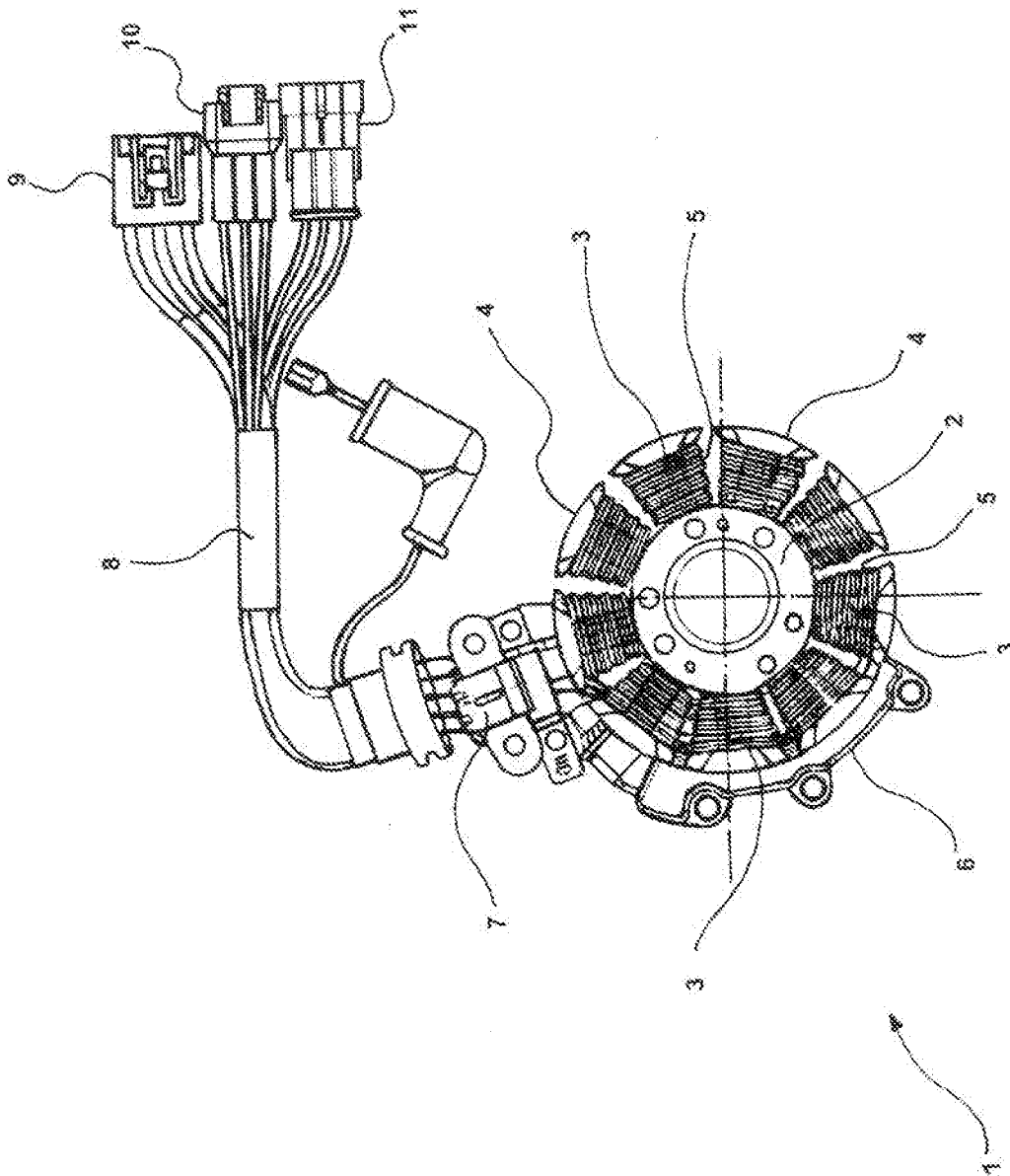

FIG.1

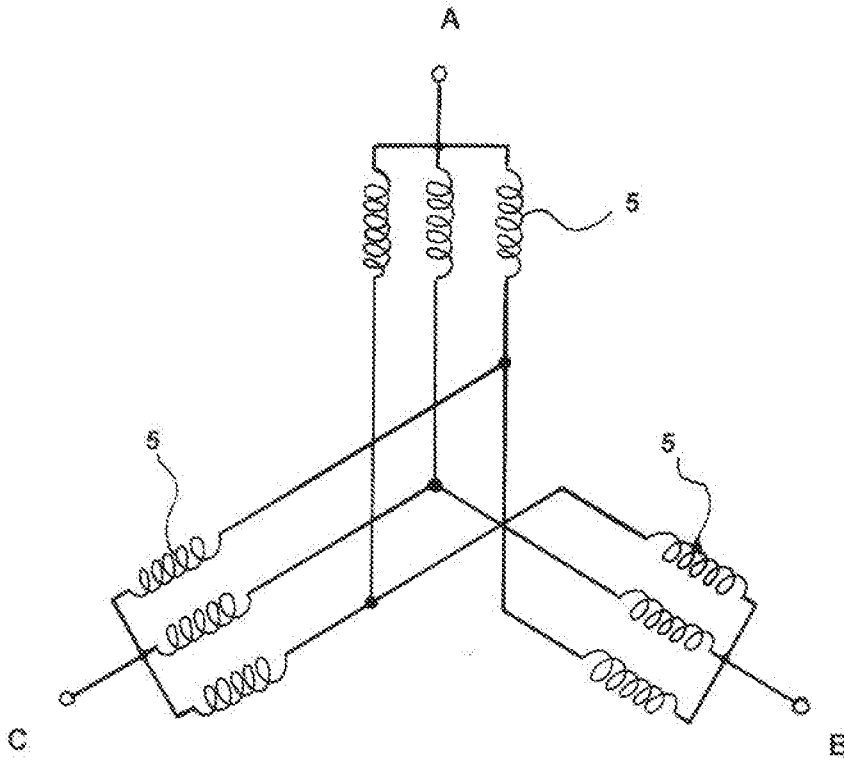
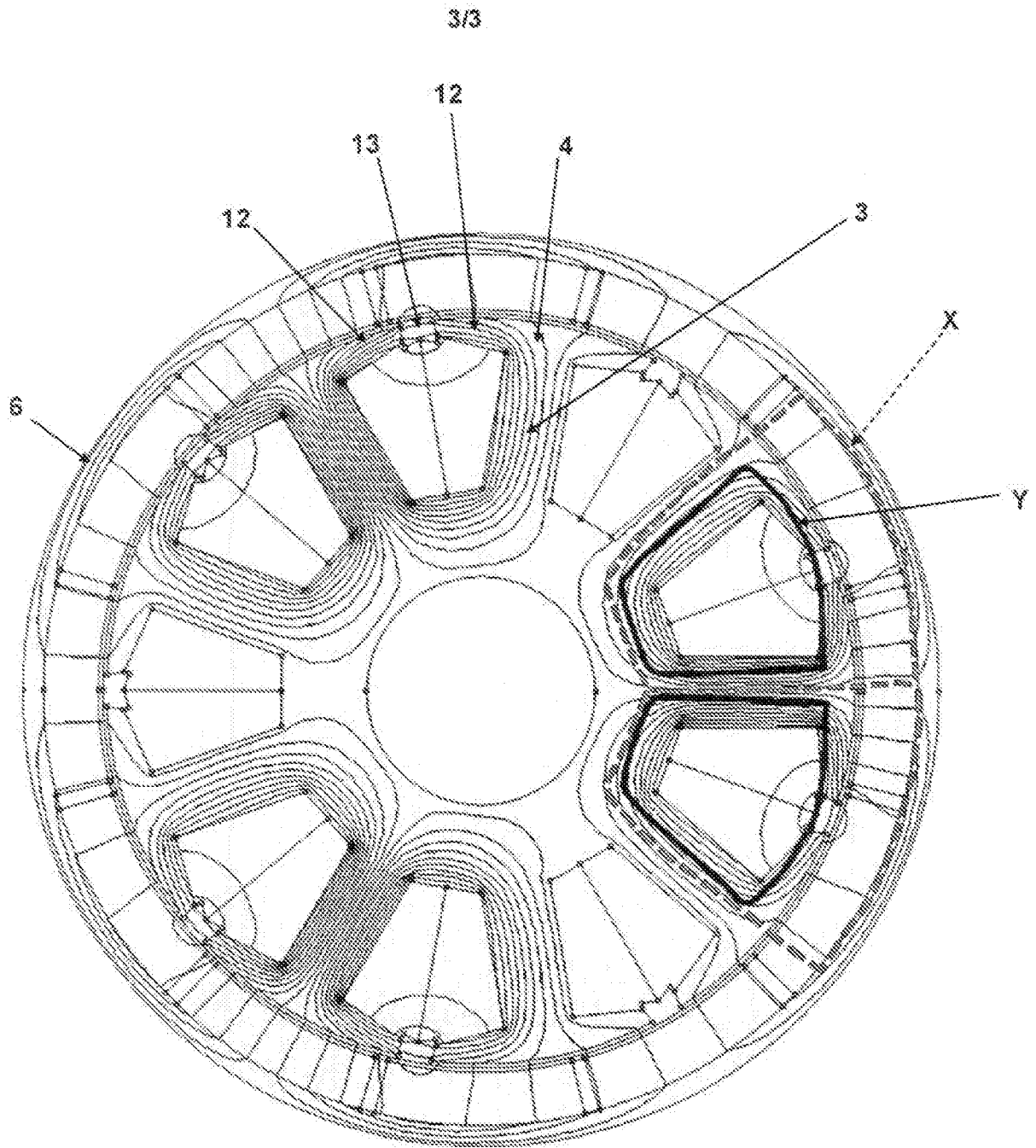

FIG.2



**Fig. 3**