

(No Model.)

2 Sheets—Sheet 1.

T. J. THORP. BROOM.

No. 446,901.

Patented Feb. 24, 1891.

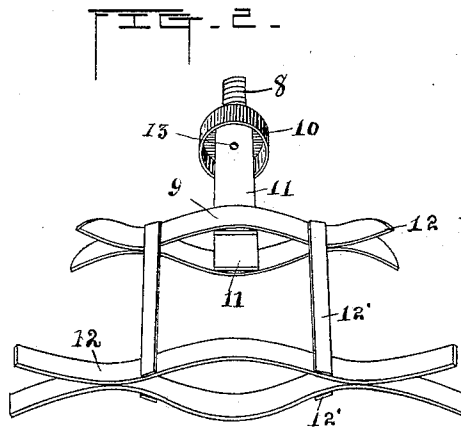
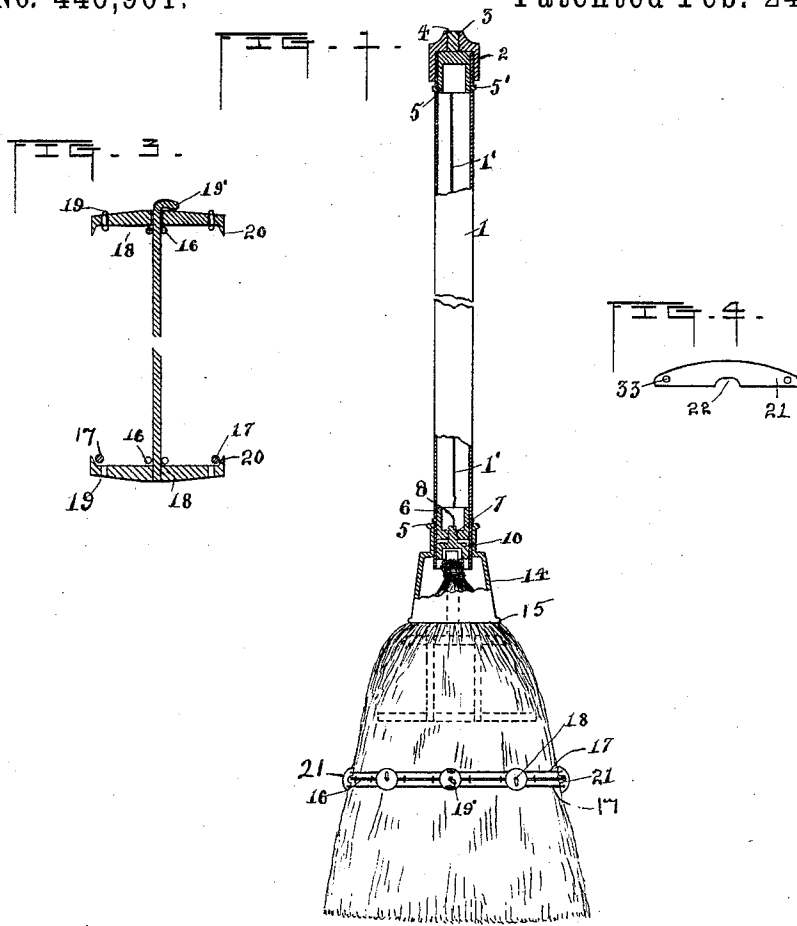

Witnesses
 Arch. M. Catlin
 John Callan

Inventor
 Thomas J. Thorp

By his Attorneys

Benj. R. Catlin

(No Model.)

2 Sheets—Sheet 2.

T. J. THORP.
BROOM.

No. 446,901.

Patented Feb. 24, 1891.

FIG. 5.

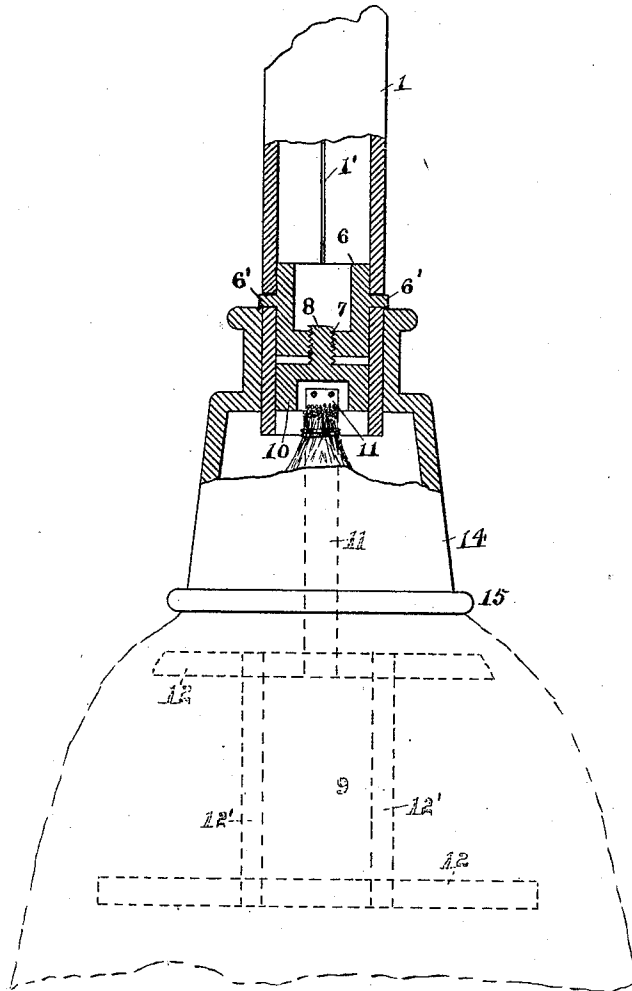

Witnesses
And M. Catlin
David Bonar

Inventor
Thomas J. Thorp
by
Benj. R. Cadie Attorney

UNITED STATES PATENT OFFICE.

THOMAS J. THORP, OF CHICAGO, ILLINOIS, ASSIGNOR OF ONE-THIRD TO
CHARLES J. BARNES, OF SAME PLACE.

BROOM.

SPECIFICATION forming part of Letters Patent No. 446,901, dated February 24, 1891.

Application filed July 9, 1890. Serial No. 358,221. (No model.)

To all whom it may concern:

Be it known that I, THOMAS J. THORP, a resident of Chicago, in the county of Cook and State of Illinois, have invented certain new and useful Improvements in Brooms; and I do hereby declare the following to be a full, clear, and exact description of the invention, such as will enable others skilled in the art to which it pertains to make and use the same.

The invention relates to brooms having detachable handles, frames, and fastening-wires; and it consists in the construction hereinafter described, and pointed out in the claims.

In the accompanying drawings, Figure 1 represents a side elevation, partly in section, of my improved broom. Fig. 2 is a perspective of a skeleton. Fig. 3 is a central section of a binding device. Fig. 4 is a side view of a distance-piece, and Fig. 5 is a partial section showing devices for joining the brush and handle.

Numeral 1 indicates the body of a broom-handle consisting of a tube, preferably nickel-plated. The upper end is closed and finished by any suitable means, such as shown. A cap 2 has an internal screw-threaded opening 3, adapted to be screwed onto the threaded stem 4 of a plug 5, secured by any convenient means in the interior of the tube.

5' indicates projections or stops rigidly secured in the plug 5 by screw-threads, solder, or equivalent means, and extending through perforations in the tube. Said projections can be cast upon the plug and the latter introduced in the tube, the projections being entered in the proper openings before the longitudinal joint 1 of the tube is fully closed. The upper end of the tube having been entered in the cap 2 and the screw engaged with the socket in the plug and the cap screwed down until the tube bears on the bottom of the recess in the cap, suitable terminal that will properly hold the tube is thereby produced.

6 denotes a plug similar to that above described, provided with like projections 6'. It has a screw-threaded opening 7 to receive a screw 8, formed on the plug 10.

9 indicates a skeleton having arms 11, which are secured to the plug 10 in a recess therein. Said skeleton is of special form, adapted to

receive and hold the broom-corn. It has two transverse members 12, each composed of curved bars and two pairs of vertical bars 12'. This device is preferably made of malleable iron. The skeleton having been secured to the plug and tube by the means described, or by like devices, the brush is built upon it in suitable form and its upper end wound with wires, the ends of which before beginning to wind are inserted in holes, such as indicated at 13.

14 denotes an approximately cone-shaped tube or thimble which is made to receive and hold the bottom of tube 1, and which incloses the arms 11. These arms are a part of the skeleton 9, and are each fastened by rivets or other means on a side of the socket in plug 10. One of these arms appears in Fig. 5 secured in place, the other being cut away. After the broom-corn has been laid and suitably formed about the frame 9 and its upper ends have been wired in usual manner the thimble 14 is forced down upon the shoulder of the broom at 15 by turning the handle and its contained screw-threaded plug, so that they are drawn down upon screw 8 toward the brush or broom proper.

In addition to the usual tying and binding string, such as indicated at 16, I employ the wires 17, which are passed under the disks, buttons, or bars 18, placed at convenient intervals. The wire ends are secured to the buttons by means of holes 19 or otherwise. Said buttons are arranged in pairs and connected through the broom-brush by means of wires secured thereto in any convenient manner. Preferably the wires are at one end permanently attached to one button and detachably fastened to the other by bending their ends down upon the same after having been passed through it, as shown at 19'. Teeth 20 are provided to hold the buttons more securely in place.

21 is a distance-piece, notched at 22 to embrace the binding thread or cord, and perforated at 23 to receive the wire 17. These pieces operate to hold the wires in proper relative position, and are most advantageously placed in the edge of the broom.

The tubular handle, being made of light metal, is stiffened at each end by an interior

plug and an external cap or thimble. The split in the tube enables the projections of the plugs to be entered in holes in the tube when slightly expanded, the longitudinal opening in the tube being subsequently closed and the cap and thimble placed thereon.

When the brush of a broom is worn out, a fresh one can be supplied to the frame and handle and bound with wire and thread, as set forth, or in any approved manner, and these devices of my invention can be reused many times with economy and convenience.

Having thus described my invention, what I desire to secure by Letters Patent is—

1. A tubular broom-handle made of elastic material and having interior plugs at each end provided with projections engaging holes in said handle, a cap surrounding the upper end and engaged with the plug, and a flaring

thimble surrounding the opposite end, adapted to cover the upper end of the broom-fiber, substantially as set forth.

2. In a broom, the skeleton having the transverse outwardly-curved bars, the intermediate connecting-bars 12', and arms 11, in combination with a tubular handle provided with a plug secured therein and secured to the arms 11 of the skeleton, the latter being concealed within and supporting the broom and having a part of the same between its transverse members, substantially as set forth.

In testimony whereof I have signed this specification in the presence of two subscribing witnesses.

THOMAS J. THORP.

Witnesses:

HANNAH M. CLOUD,

COREY A. KENNEDY.