

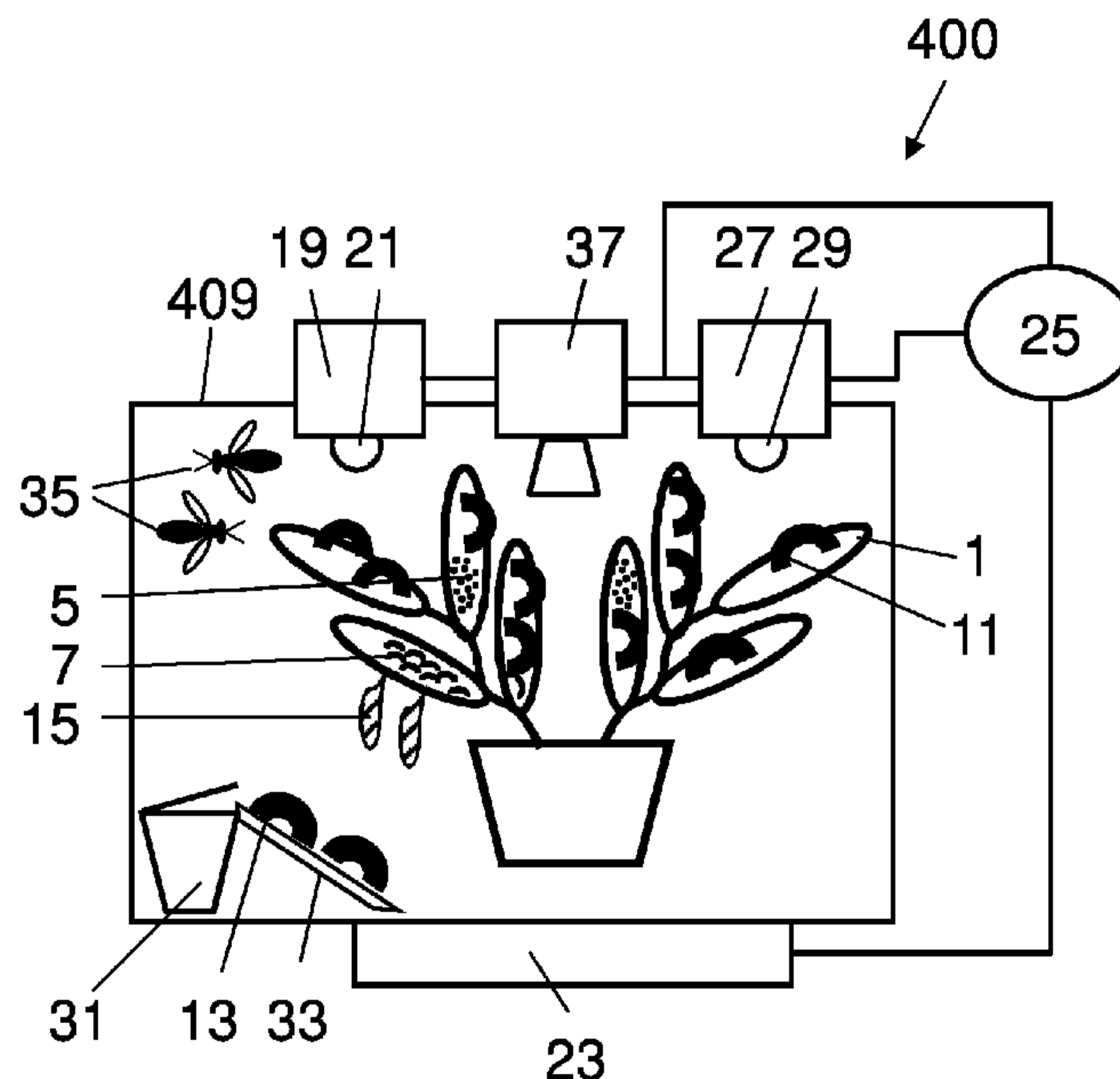

- (51) International Patent Classification:  
*A01K 67/033* (2006.01) *A01G 9/16* (2006.01)
- (21) International Application Number:  
PCT/EP2020/081027
- (22) International Filing Date:  
05 November 2020 (05.11.2020)
- (25) Filing Language: English
- (26) Publication Language: English
- (30) Priority Data:  
19207609.9 07 November 2019 (07.11.2019) EP
- (71) Applicant: **SIGNIFY HOLDING B.V.** [NL/NL]; High Tech Campus 48, 5656 AE Eindhoven (NL).
- (72) Inventor: **DE SAMBER, Marc André**; c/o High Tech Campus 7, 5656 AE Eindhoven (NL).
- (74) Agent: **VANDEN WYNGAERT, Hilbrand et al.**; High Tech Campus 7, 5656 AE Eindhoven (NL).
- (81) Designated States (*unless otherwise indicated, for every kind of national protection available*): AE, AG, AL, AM, AO, AT, AU, AZ, BA, BB, BG, BH, BN, BR, BW, BY, BZ, CA, CH, CL, CN, CO, CR, CU, CZ, DE, DJ, DK, DM, DO, DZ, EC, EE, EG, ES, FI, GB, GD, GE, GH, GM, GT, HN, HR, HU, ID, IL, IN, IR, IS, IT, JO, JP, KE, KG, KH, KN, KP, KR, KW, KZ, LA, LC, LK, LR, LS, LU, LY, MA, MD, ME, MG, MK, MN, MW, MX, MY, MZ, NA, NG, NI, NO, NZ, OM, PA, PE, PG, PH, PL, PT, QA, RO, RS, RU, RW, SA, SC, SD, SE, SG, SK, SL, ST, SV, SY, TH, TJ, TM, TN, TR, TT, TZ, UA, UG, US, UZ, VC, VN, WS, ZA, ZM, ZW.

(54) Title: METHOD AND SYSTEM FOR CULTIVATING INSECTS



**Fig. 6**

(57) **Abstract:** The present disclosure relates to a method and a system for growing plants and insects. In particular the present disclosure relates to a method for cultivating insects (5, 11, 15, 35), comprising providing herbivorous and/or omnivorous insects in a container (409) for confining the insects, and providing live plant material (1) as feedstock for the insects. The method comprises providing one or more live plants in a plant growing medium and exposed to the insects as the feedstock plant material, and controlling in at least part of the container at least one control parameter selected from temperature, humidity, illumination, air composition, additional feedstock for at least part of the insects, amount of the plant material and composition of the plant growing medium, for stimulating growth of the insects and/or the one or more live plants, more specifically for selectively stimulating growth of the insects in dependence on the growth of the one or more plants or selectively stimulating growth of the one or more plants in dependence on the growth of the insects.



**(84) Designated States** (*unless otherwise indicated, for every kind of regional protection available*): ARIPO (BW, GH, GM, KE, LR, LS, MW, MZ, NA, RW, SD, SL, ST, SZ, TZ, UG, ZM, ZW), Eurasian (AM, AZ, BY, KG, KZ, RU, TJ, TM), European (AL, AT, BE, BG, CH, CY, CZ, DE, DK, EE, ES, FI, FR, GB, GR, HR, HU, IE, IS, IT, LT, LU, LV, MC, MK, MT, NL, NO, PL, PT, RO, RS, SE, SI, SK, SM, TR), OAPI (BF, BJ, CF, CG, CI, CM, GA, GN, GQ, GW, KM, ML, MR, NE, SN, TD, TG).

**Declarations under Rule 4.17:**

— *as to applicant's entitlement to apply for and be granted a patent (Rule 4.17(ii))*

**Published:**

— *with international search report (Art. 21(3))*

## METHOD AND SYSTEM FOR CULTIVATING INSECTS

## FIELD OF THE INVENTION

The present disclosure relates to a method and a system for growing plants and insects. In particular the present disclosure relates to a method for cultivating insects, comprising providing herbivorous and/or omnivorous insects in a container for confining the insects, and providing plant material as feedstock for the insects.

Likewise, the present disclosure relates to a system for cultivating insects according to the above-referenced method, comprising a container for confining herbivorous and/or omnivorous insects, one or more live plants in a plant growing medium, and a controller for controlling in at least part of the container at least one control parameter selected from temperature, humidity, illumination, air composition, feedstock for at least part of the insects, and nutrient composition in the plant growing medium.

## BACKGROUND OF THE INVENTION

Consumption of insects by humans (also entitled entomophagy) is practised in many countries around the world although primarily in parts of Asia, Africa and Latin America. Insects supplement the diets of approximately 2 billion people (reference: FAO website) and have always been part of human diets.

Recently food industry, research institutions, legislators and agencies have also started paying attention to further exploitation of insects for food and feed (e.g. to nourish fish in aquaculture, or poultry). This is because of the rising need for high-quality animal proteins needed to feed a growing and increasingly prosperous world population.

The production of insect protein is a potentially promising addition of protein from other sources such as meat, dairy and eggs. Also, insect (protein) can be used to feed livestock.

The environmental impact of insect production seems to be relatively low compared to alternative protein sources such as legumes, algae or laboratory meat, and presents a particularly environmentally-friendly option if insects can be fed using readily available feed (or even waste). Also, the conversion factor of nutrient to insect protein is high because insects are cold-blooded (so no energy is used to maintain an elevated core body

temperature). Insect farming in general is much more environmentally friendly than traditional livestock farming (for greenhouse emissions, CO<sub>2</sub> emission can be up to 100 times lower than for farm animals, and nitrogen emissions up to ten times lower).

Next to the need to be able to produce for competitive cost price, a main issue is in potential public health risks. When using insects for food, the insects can be eaten either alive or freshly killed as whole insect, or after processing them into a food source or extract.

As whole insects still contain their gut microflora, these microflora (bacteria) may affect the microbiological quality of food of dead (killed) insects. Harmful toxins might be formed because of the degradation of the insect's body tissues.

Therefore, and possibly in particular in case of insects for human consumption, it is desired, e.g. for reasons of food safety and hygiene, that insects may be provided as fresh insects, in particular as whole and live insects. In most cases, the larvae or prepupae are the stages of interest for consumption, rather than the adult stages.

Therefore methods and systems for cultivating insects of the aforementioned kind are developed. E.g. KR 101812211 B1 relates to a solar power generation container for plant cultivation and insect breeding and, more specifically, relates to a solar power generation container for plant cultivation and insect breeding, capable of efficiently maintaining optimal environments for plant cultivation and insect breeding as well as considerably reducing costs for maintenance by obtaining electric energy from solar power generation as a basic energy source for plant cultivation and insect breeding. The solar power generation container comprises: a body part including a partition to divide a cultivation area and a breeding area; a planting part including a lighting unit installed in the cultivation area to emit an LED light source to seedlings, and forming a plant cultivation environment; an insect breeding part installed in the breeding area of the body, and forming a breeding environment in which insects are stored and raised; a temperature and humidity air conditioner comprising an air conditioning unit installed in the upper part of the body part and sending air formed at a set temperature and humidity, a temperature and humidity measurement unit measuring temperature and humidity in the body part; and a conditioning control part applying a control signal to the air conditioning unit in accordance with a measurement signal of the temperature and humidity measurement unit; and a solar power generation device installed in the body part, and generating electric energy to supply to the planting part, the breeding part, and the air conditioner by receiving solar light sources.

CN 102 523 974 A discloses a crop and insect co-cultivation box suitable for feeding herbivorous crop insects and cultivating crops at the same time. The co-cultivation

box comprises a plant raising tray for receiving soil and plants to grow, a nutrient supply system for supplying water and nutrients to the plants, a light source for providing light in the co-cultivation box, and a fan and a gauze covering the top of the co-cultivation box for removing heat from the light source out of the co-cultivation box. The crop and insect co-cultivation box can be applied to crop and insect interaction researches such as crop cultivation, insect raising, insect resistance of crop, and identifications on disease resistance of bacteriosis and virus of insect mediators.

Further improvements for cultivation of insects are desired.

## 10 SUMMARY OF THE INVENTION

Herewith a method and a system for cultivating insects are provided as set out in more detail below.

The method comprises providing one or more live plants in a plant growing medium and exposed to the insects as the feedstock plant material, and controlling in at least part of the container at least one control parameter selected from temperature, humidity, illumination, air composition, additional feedstock for at least part of the insects, amount of the plant material and composition of at least part of the plant growing medium, for stimulating growth of the insects.

Similarly, the system comprises that the live plants are arranged in the container to be exposed to the insects in the container as feedstock for the insects and that the controller is configured to control the least one control parameter for stimulating growth of the insects.

Preferably at least part of the insects are cultivated in a larval stage and the one or more live plants being exposed to the larvae as the feedstock for the larvae, then, the container may be configured for confining at least the larvae and the controller may be configured to control the least one control parameter for stimulating growth of the larvae.

By providing live plants as feedstock, rather than the dead and/or decaying material, the insects are provided with fresh feedstock. This may improve health of the insects, and therewith quality of the insects for harvesting as foodstuff, compared to providing dead and/or decaying plant material as feedstock. It also may reduce risks of mould, fungi, odours, luring of pests, contamination of nearby objects and/or other unwanted aspects of decaying products and instead provide the pleasant atmosphere of a live plant. The insects may be harvested for processing and/or consumption fresh. By providing the feedstock for the insects in the form of one or more live plants, provision of additional

feedstock may be reduced to keeping the one or more plants alive, thus transportation of feedstock for cultivating insects may be minimized. Live plants consume carbon dioxide and produce oxygen and they produce humidity in their environment; thus, an atmosphere for (the larvae of) the insects may be maintained in good quality, in particular, in better quality than if the insects were to be provided with dead and/or decaying material to feed on.

Conversely, live animals including insects consume oxygen and produce carbon dioxide, and they tend to thrive in dependence on humidity in their environment. Moreover excrements from (the larvae of) the insects may form a fertilizer for the one or more plants. thus the plants may benefit from exposure to the insects.

By controlling in at least part of the container at least one of the control parameters, growth of the insects may be stimulated. The controlling may relate directly to the insects like one or more of temperature, humidity, illumination, air composition, additional feedstock for at least part of the insects. The controlling may also relate indirectly to the insects and relate directly to (stimulating conditions for) the one or more plants: one or more of temperature, humidity, illumination, air composition, growth of the plant material; since a healthier and/or faster-growing plant tends to provide more and better quality food to the insects than a less healthy and/or slower growing plant, this improves health and/or growth of the insects, and in some cases possibly improves insect proliferation. Growth of the plant may depend on composition of at least part of the plant growing medium, e.g. volume, humidity, composition and/or structure, nutrients (e.g. fertilizer), acidity, temperature, etc., any which may be detected by one or more suitable detectors. Insects, at least in a larval stage, may thrive and grow best at different conditions than optimum for plant growth. This facilitates selective optimisation towards insect growth or towards plant growth. E.g., plants need light to grow, as their growth is based on photosynthesis. Larvae of insects and insects need food and high enough temperatures (as they are cold-blooded) for homeostasis and growth. Further, both plants and larvae require sufficiently well controlled other environmental conditions. The co-existence and specific control of insect growth versus plant growth can therefore be arranged by stimulating plant growth by light and/or insect growth by food, at least predominantly being the food provided by the live plants.

Controlling the control parameters may ensure that the assembly of the insects and the one or more plants may be substantially free from other species that may be considered as contaminants to the assembly, e.g. undesired plant and/or insect species, fungi, parasites etc.

Sufficiently grown insects, in particular at least part of the larvae and/or prepupae, may be harvested and used as, or for, food or feed for animals, including primates including humans. Note that it may be generally preferred to harvest the insects as larvae or prepupae, rather than as pupae or adult insects. Moreover, since the larvae are generally the development stage in which most protein is amassed per individual insect and per unit of time, harvesting of larvae may be the most economic manner of cultivating insects; whereas larvae of most insect species may eat voraciously, pupation costs time and energy and adults may eat little or not at all, and/or feed on significantly different substances (e.g. leaf-eating larvae vs. nectar-drinking adults). The larvae may therefore benefit most from the advantageous aspects of providing fresh and living plant material as feedstock.

It is further noted that in this disclosure, “larva” refers to any larval stage of the insect which may be referred to by different names: e.g. larva, maggot, mealworm, grub, caterpillar, inchworm, etc. Generally larvae of an insect species will grow and moult several times, an individual larval substage between successive moltings is commonly referred to as an “instar”. “Prepupa” refers to larvae in their final moulted larval stage (the final instar) which will transform themselves into the pupae, in turn developing into the adult stage (imago). Some insects may also develop further in the adult stage, possibly including molting as well.

Different instars of an insect species may have different characteristic appearances, e.g. with respect to patterning, colouring, number or shape of bristles and/or appendages. Further the number of moulting / instars between hatchling/neonate (larva as it emerges from an egg) and pupa tends to be insect species specific. Also, different instars may accept or prefer different types of feed. This may facilitate detection and/or controlling development of the insect growth; see also below.

The container serves to confine the insects. In particular, the container may be configured for confining the insects in any life stage, in particular in an adult life stage, and the method may comprise allowing and/or urging the insects to multiply within the container.

Thus, a substantially closed circular method for cultivating insects may be provided, based on cohabitation of plants and insects. It is noted that some insects desire particular conditions for mating, e.g. with regard to one or more of temperature, light conditions, humidity of air, humidity of surfaces, and/or in particular with respect to air compositions such as scents, aerosols, pheromones, animal odours, plant odours signalling plant development stages, etc. In the container, such conditions may be (re-)created and/or mimicked in a controlled environment.

E.g., a suitable container may comprise at least in part a cage and/or a grid-structure providing one or more openings. Also or alternatively, the container may comprise solid walls which may preferably be at least partly at least translucent, preferably transparent, e.g. plastic and/or glass, providing light to the one or more plants and/or facilitating  
5 observation of the plant(s) and insects. A substantially enclosed container may facilitate defining and/or maintaining one or more of the control parameters.

The method may further comprise controlling in at least part of the container, preferably the part of the container in which the control parameters are controlled or at least are controllable for stimulating growth of the insects, at least one of the control parameters  
10 for stimulating growth of the at least one plant in dependence on at least one of growth of the insects and growth of the plant.

Similarly, in the system, the controller may be configured to control at least one of the at least one control parameters for stimulating growth of the one or more plants.

For example, suitable temperature, humidity, and light etc. may be provided,  
15 see also discussion elsewhere herein; further, one or more of water, soil and fertilizers may be provided. As indicated before, plants and insects, at least in a larval stage, may flourish and grow best at different conditions. Control at least one of the at least one control parameters for stimulating growth of the one or more plants facilitates selective optimisation towards plant growth. Also or in addition, stimulating growth of the one or more plants may  
20 provide that the plant produces plant material in synchronisation with growth of the insects and/or their feeding habits; this may ensure reduction of requirements for (additional) feedstock during cultivation, with an associated reduction of transport of such (additional) feedstock. Additional feedstock may comprise nutritious substances and/or feedstock for different life stages such as sugar water for adults whereas the larvae feed on the one or more  
25 plants.

The method may further comprise controlling in at least part of the container at least one of the control parameters for selectively stimulating growth of the insects and/or growth of the at least one plant in dependence on at least one of growth of the plant and, respectively, growth of the insects; in particular controlling in at least part of the container at  
30 least one of the control parameters for selectively stimulating growth of the insects in dependence on the growth of the one or more plants or stimulating growth of the one or more plants in dependence on the growth of the insects.

Thus, it may be selected to stimulate growth of the insects for providing a rich insect harvest in case of sufficient growth of the plant(s), or, alternatively, it may be selected

to stimulate growth of the one or more plants for keeping up with growth and feeding requirements of the insects.

Besides improving quality of the insects, by providing and maintaining both the insects and their food in live condition, some form of cohabitation or symbiosis may be achieved between both live forms, resulting in a recurrent and possibly predictable harvestable amounts of insects of such high quality.

In any embodiment, the condition of the insects and/or of the one or more plants, and where applicable growth thereof, may be stimulated such that at a time when one or more insects of a particular development stage are ready for harvesting, e.g. larvae, preferably all larvae, the feedstock plant material may be finished and the one or more plants be effectively spent. However, it may be preferred that at least one of the control parameters is controlled such that at least one of the one or more plants survives and continues growing, possibly for repeated and/or continued performance of the method, the one or more plants providing the plant material as feedstock for one or more subsequent insect generations. Thus, the system may enable running multiple and consecutive cycles for an extended period. The number and/or size of the one or more plants, possibly together with their (predicted) growth parameters may be selected with respect to the (desired and/or predicted) growth and/or nutritional needs of the insects during the cultivation.

Also or in addition, selective stimulation may comprise alternating periods of stimulating growth of the insects and stimulating growth of the one or more plants, so that the plant(s) can recuperate, for stimulating an optimum co-habitation and possibly an average equilibrium between insect growth and plant growth; an optimum control may be determined with respect to the combination of plants and insects, rather than focusing on growth of the insects or on that of the one or more plants.

Also or in addition, selective stimulation may comprise providing periods of stimulating growth of only a particular stage of the insect life cycle and/or stimulating growth of the one or more plants and reducing or even preventing growth of at least one stage of the insects, e.g. for recovery of the one or more plants and/or for synchronising development of the insects, or at least several thereof, with respect to each other such as synchronised growing of the larvae and/or synchronised maturity for mating.

E.g., the method may comprise adjusting in at least part of the container at least one of the control parameters, for stimulating synchronisation of growth and/or development of plural individuals of the insects with respect to each other.

Such synchronisation of growth and/or development of plural individuals of the insects with respect to that of each other may comprise one or more of stimulating multiple insects to grow / develop at (substantially) the same rate, stimulating the insects to reach the same stage (e.g. a particular instar) simultaneously and/or to remain in a particular stage.

The system may comprise at least one detector for detecting in the at least part of the container at least one of a temperature, humidity, illumination, air composition, plant growth and composition of the plant growing medium, the controller and the detector being coupled for controlling in at least part of the container the at least one control parameter on the basis of one or more signals from the detector.

Such system facilitates checking and control and feedback, therewith reliable operation may be ensured. Suitable detectors may comprise at least one of a thermometer, hygrometer, gas analyser, weight sensor, light intensity meter, spectrograph, camera, etc.

The method may comprise detecting at least one plant life parameter of the at least one plant; and adjusting in at least part of the container at least one of the control parameters on the basis of the detected at least one plant life parameter.

The system may comprise at least one detector for detecting in the at least part of the container at least one insect life parameter of the insects and/or at least one detector for detecting in the at least part of the container at least one plant life parameter of the one or more plants.

Thus, monitoring and control and possibly a feedback-arrangement may be provided. Focus may be on growth of the insects or growth of the plant(s), but preferably, focus is on thriving of the assembly as a whole e.g. like a limited ecosystem, wherein the one or more plants are healthy and grow despite being eaten by the insects and the insects are healthy and grow stably and securely to provide a rich harvest. The plant growth may be slower or faster than the eating of the insects but preferably it is stimulated such that the plant's growth or growth rate matches the consumption or consumption rate of the insects so that an equilibrium is achieved. Note that such equilibrium may be attained for prolonged periods or only on average if cultivation is performed periodic as discussed above, in which case in periods of stimulating growth of the insects the plant(s) may be eaten faster than it/they can grow, and in subsequent periods of stimulating growth of the one or more plants, the plant(s) can grow faster than it/they are eaten so that the plant(s) can recuperate. In such plant recuperation period, growth of insects may be reduced e.g. by controlling one or more of the control parameters as explained herein elsewhere.

One detector may suffice for detecting at least one insect life parameter and at least one plant life parameter. E.g. a suitable detector may comprise a camera providing image data from at least part of the container; image data from the camera may be assessed by a human operator and/or be at least partly processed by an image processor and/or  
5 detection program for assessment of a condition and/or of growth of the plant and/or of the insects. E.g. suitable life parameters of the at least one plant may comprise: size, number, density, shape, position, colour and/or turgor, etc. of one or more of leaves, petals, buds, stems, branches and stalks etc.; suitable life parameters of the insects may comprise: size, number, density, colour, pattern, shape, state, development state and/or age distribution,  
10 reproduction rate, motility, of individual insects or rather groups of the insects, any of which may be considered with respect to the insects in one or more particular stages such as neonate larvae, larvae (one or more particular instars), prepupae, and/or adults, and in the latter case possibly, if the adults also moult one or more times, for one or more particular adult moulted stages.

15 Using (camera) vision is an option for one or more of detecting, measuring and evaluating the condition of the one or more plants. E.g., one can look at and/or analyse the number and/or shape of leaves, such as looking for and/or analysing cut-outs caused by insect feeding on the plant and/or curling of leaves caused by one or more of too much affected, drying out and starting to die, looking at a number of remaining leaves. Using vision  
20 is also an option for one or more of detecting, measuring and evaluating a condition of the insects, e.g. their mobility, growth rate, colouring, response to (simulated) threats. Here, preferably, account may be given for movement of the insects. If the insects (in any development phase) are in a line-of-sight, then a camera may detect them. One option is using feature recognition, which may be performed using any known computer vision  
25 method. In images or image data representative of images insects may be identified and/or quantitative and/or qualitative analysis may be performed, e.g. one or more of size, development stage and number of insects in one or more stages. Counting individuals may comprise counting a number of recognized features and/or clustering these in clusters or groups.

30 It is, again, noted that it may be preferred to operate the method and the system with a focus on thriving of the assembly as a whole, in which case it may suffice to monitor one or more conditions of the one or more plants, which may generally be easier to determine than conditions of the insects. E.g., changing of illumination and/or temperature may be maintained within certain limits selected for stimulating plant growth.

Also or alternatively, one or more sensors for atmosphere composition and/or one or more specific components thereof may be provided. E.g., sensors for oxygen, carbon dioxide, ethylene, humidity and/or for other substances may be employed.

The method may comprise providing a light source and providing illumination  
5 by the light source in at least part of the container, and controlling at least one of intensity and spectral power distribution, as a function of time and/or position in the part of the container. Controlling intensity as a function of position is also known as intensity distribution, for example in the part of the container.

Such control of illumination as a control parameter facilitates selective  
10 stimulation of growth of the insects and the one or more plants.

The system may comprise a light source for providing illumination by the light source in at least part of the container, wherein the controller is functionally connected with the light source and is configured for controlling at least one of intensity and spectral power distribution of the illumination as a function of time and/or position in the part of the  
15 container.

Intensity control may comprise providing relatively brightly-lit areas and/or relatively dark areas. Bright areas may promote plant growth. Dark areas may be preferred by larvae, in particular in later developmental stages, believed to be an evolutionary safety mechanism to hide from view of predators (e.g. birds, in the wild). Relatively bright areas  
20 may therefore promote plant growth and reduce density of larvae. Relatively dark areas may be provided for increasing larvae-density and/or for attracting mature larvae; this may facilitate harvesting the larvae at such location. As indicated before, adult insects may prefer relatively brighter areas.

Plants and larvae tend to prefer, and/or thrive on, light of mutually different  
25 wavelengths and/or wavelength ranges. E.g. infrared radiation may provide warmth. For insects, different life stages (larva, prepupa, pupa, adult, possibly even: egg) may respond mutually differently to one or more of intensity and spectral power distribution. E.g., larvae may eschew light in particular wavelength regions while the adult stage uses vision in the same or different wavelength regions for identifying suitable mates. Short (blue) wavelengths  
30 may be harmful to insect larvae and in some cases, in particular when at high intensity, can even be lethal to young larvae; however older larvae tend to be less susceptible. Further, response of larvae to shorter wavelengths (blue, violet, near-UV) tends to be stronger than for longer wavelengths (green, red, near IR). Plants tend to thrive least on green light and better on shorter and longer wavelengths (blue, violet, near-UV; red, near IR). One might use this to

manipulate the growth of the larvae (so harm a little to disrupt and slow down growth of larvae, without killing them). Control of spectral power of the light may therefore affect differently plants and insects, in particular different stages of the insects.

Various wild and domesticated insects (almost always the larvae of these) are considered for use as human food and/or as feed for other animals in agriculture. Particularly suitable insects for the present concepts may comprise black soldier fly (*Hermetia Illucens*), cucumber beetle (*Diabrotica undecimpunctata*), five-spotted hawkmoth (*Manduca quinquemaculata*), various types of butterfly and moths. Adult insects that are considered as food and/or feed are e.g. grasshoppers (*Acridomorpha*) and locusts (*Schistocerca gregaria*). Moreover, insects and/or larvae feed on plants that are easy to cultivate such as cucumber (*Cucumis sativus*), tomato (*Solanum lycopersicum*), cabbage types (*Brassica*) and grasses (*Poaceae*).

The black soldier fly (*Hermetia Illucens*) is particularly beneficial in that the larvae eat nearly all plant material, grow fast, are well sought-after fish and poultry food and are also considered tasty by many; the adults do not eat or sting and are no known pests or diseases carriers for livestock or humans. In more detail: it has a short life cycle of about 30-40 days; a high fecundity of about 900 eggs per spawn; the larvae are harvestable about 10-12 days after hatching; the larvae and prepupae have relatively low chitin content.

The one or more live plants may comprise herbs and/or leafy plants; these tend to be preferred by insects and insect larvae as they provide more nutritious plant material, provide more edible plant material, and (re-)grow faster than other plant types. E.g. the one or more plants may comprise cucumber plants, squash plants, pumpkin plants, zucchini plant, tomato plants, etc. but also brassica and grasses ... (see also above). Relevant parameters for assessing suitable feedstock plants may comprise: protein content, fibre content, starch content.

For the purpose of growing larvae in an artificial setting and with the aim to provide a stable and easy picking method, leafy plants may be selected: any type that has most of the following characteristics can be considered: strong; well growing and capable to cope with (high) numbers of larvae feeding on it (so the plant can recover sufficiently from feeding damage); containing the preferred nutrients for the larvae (protein, starch, fibre ratio); long enough lifespan (preferably at least one larvae harvest run; more preferably and in particular for prolonged cultivation or a closed system as discussed elsewhere herein, the plants should survive for longer periods and multiple larvae development cycles); non-toxic

to the larvae, i.e. the plant(s) should not have built-in defence mechanisms for the insects (to be) cultivated.

The system may comprise, in or at least connected to the container, a receptacle for collecting at least one of larvae, prepupae and pupae. Then, the system may  
5 comprise a receptacle controller, at least part of the receptacle and the controller being connected and configured that at least part of the receptacle is controllable or controlled with respect to at least one of temperature, humidity, illumination, air composition.

In view of the foregoing, at least part of the insects may be harvested by collecting the insects in a receptacle provided in or attached to the container. E.g., a cup or a  
10 basket may be provided into which the insects may enter and be captured. In particular, larvae may be unable to crawl out of a receptacle having sufficiently steep and/or non-sticky wall portions, e.g. near-vertical or even overhanging wall portions and/or walls having particular surface properties. Since the insects may be attracted to dark areas, a receptacle may be formed by or provided with a canopy or shady entrance. Also or alternatively, part of  
15 the receptacle, e.g. an entrance thereof may be marked by light of particular properties and/or particular smells e.g. pheromones. Also, or in addition, a particular temperature may be provided wherein the temperature may be chosen to lure the insects for pupating. Alternatively, at least part of the receptacle may be chilled to slow down further development of the larvae in the receptacle. Note that controlling one or more of light, air composition  
20 and/or quality, humidity and (in particular) temperature may also serve for preserving one or more insects in the receptacle.

#### BRIEF DESCRIPTION OF THE DRAWINGS

Fig. 1 indicates a method of cultivating insects;  
25 Figs. 2 and 3 shown two phases of the method;  
Figs. 4-6 show different systems for cultivating insects;  
Fig. 7 indicates a method of cultivating insects.

#### DETAILED DESCRIPTION OF THE EMBODIMENTS

30 It is noted that the drawings are schematic, not necessarily to scale and that details that are not required for understanding the present invention may have been omitted. The terms "upward", "downward", "below", "above", and the like relate to the embodiments as oriented in the drawings, unless otherwise specified. Further, elements that are at least

substantially identical or that perform an at least substantially identical function are denoted by the same numeral, where helpful individualised with alphabetic suffixes.

Further, unless otherwise specified, terms like “detachable” and “removably connected” are intended to mean that respective parts may be disconnected essentially  
5 without damage or destruction of either part, e.g. excluding structures in which the parts are integral (e.g. welded or moulded as one piece), but including structures in which parts are attached by or as mated connectors, fasteners, releasable self-fastening features, etc. The verb “to facilitate” is intended to mean “to make easier and/or less complicated”, rather than “to enable”. Further, words like “a”/“an”, “comprising” etc are to be understood as open  
10 specifiers, not limiting the contents and concepts of this disclosure to just the listed features but allowing additional features to be included.

As set out above, provision of larvae locally, alive and fresh prior to use is presented.

Specifically, a system and method are provided that allow locally growing live  
15 insects that can be easily harvested just before use by cultivating the insects on living plants as host and feed for the insects. More in particular, a method is provided that allows controlling the growth rate of the insects in conjunction with growing the plants (as the nutrients for the insects), allowing for timed harvesting.

The method assists in providing whole insects for food, since the insects are  
20 provided locally, alive and fresh prior to use. A system is provided that allows locally growing live insects that can be easily harvested just before use. Living plants are provided as host and feed for the insects. Controlling the growth rate of the insects and the plant nutrients for the insects may allow for timed harvesting. In an aspect, a closed circular method of insect/larvae/insect generation based on co-habitation with the host plant is provided. The  
25 method and approach allow local production (near the user) of insects, such that the user can harvest and process/consume the insects at the preferred place and time. This solves the issue of degrading tissues (and hence food quality and food safety are increased). Also, an ecological source of locally produced nutrients for the insects is provided, such that neither pre-processing nor transportation of feed to the culturing site is required.

30 Figs. 1, 2 and 3 indicate a simple embodiment e.g. for home and/or residential use and may be based on manual picking of the larvae at the moment of harvesting. Such embodiment may make use of single runs of plants and larvae. Fig. 1 illustrates a method and Figs. 2 and 3 illustrate a system 100 in two phases of the method.

In or for such embodiment, in step A one or more plants 1 in a pot 3 or other container containing soil or growing substance may be populated with eggs 5 and/or with neonate larvae 7 and placed in a container 9 for containing insects, thus providing a system 100 (Figs. 1, 2). This may be done by a supplier of the populated plant(s) so that a pre-  
5 populated plant may be sold.

Next in step B a phase of co-growth/development of the plants 1 and larvae 11 may be sustained until grown larvae 13 can be harvested in step C (Figs. 1, 3). After larvae harvesting, the system 100 might be fully cleared by removal/disposal of plant(s) 1 and any remaining larvae 11 and/or possible pupae 15 in step D. Easy/simple composting is possible,  
10 e.g. in the case of use of the black soldier fly as the insect species.

Optionally, a fresh set of eggs and/or neonate larvae may be obtained from a supplier and the plant 1 may be repopulated to start anew.

If the one or more plants 1 are pre-populated (or: re-populated) with individual eggs 5 and/or larvae 7, 11 of small enough age spread, the grown larvae 13 may be harvested  
15 all together and the plant(s) 1 may be disposed of without hatching of adult insects, even if any larvae and/or pupae 15 might have been “missed” in the harvest and remain with the plant 1.

The container 9 may be re-filled with a new pre-populated plant or, possibly depending on the material or materials of the container 9, discarded and possibly at least in  
20 part be recycled or even composted.

Fig. 4 shows another system 200 similar to system 100 of Figs 2-3; comprising an optional control system, e.g. comprising a controller 19 comprising one or more light sources 21 for controlling illumination of at least part of the interior of the container and/or a controller 23 for controlling temperature may be provided, allowing timing of growth and,  
25 hence, harvesting of larvae.

Note that if the harvesting is done before the larvae start pupating and/or in particular before the pupae hatch and adults appear, the container may need only be configured for containing larvae.

Fig. 5 shows a slightly more complex system 300 which may still be single run  
30 based (plant + eggs only used once). The system 300 comprises an optional controller 25 functionally connected with a controller 19 and light sources 21 and functionally connected with temperature controller 23 to control illumination and/or temperature in at least part of the container 9. The system 300 comprises optional further illumination controllers 27 and light sources 29 for providing illumination of different colours and/or spectral power,

functionally connected to the controller 25. In an embodiment the controller 25 may comprise a timer and a memory for operating the system 300 to control the illumination and/or temperature in accordance with a development cycle of the insects and the plant on the basis of data in the memory. The memory may comprise a look-up table and may be (re-  
5 )programmable, e.g. based on previous results. Some of the mentioned methods above might be automated and/or supported by Machine Learning and Artificial Intelligence algorithms. This allows for using big data and complex interactions.

For harvesting of the larvae, semi-automatic picking might be applied. As indicated, prepupae or larvae in later instars tend to look for darkness/shading and relatively  
10 dry spaces for pupating. A system, as shown here in Fig. 5 system 300, may comprise a relatively dark chamber or box 31 towards which the mature larvae 13 may migrate and which may serve as receptacle for the larvae. Taking advantage of the innate drive of mature larvae to move away from a ground and look for higher places, the receptacle may be provided with a ramp 33 for climbing of the larvae 13.

15 Fig. 6 shows a (semi-)closed system 400. Such closed system might be either a self-controlled and self-propagating system, or intermediate interfaces might be chosen. In the system 400 the plants 1 could be maintained during a long period and multiple insect cycles would run with that plant infrastructure, i.e., the container 409 should be configured for confining the insects of all or at least most stages, like eggs 5, neonate larvae 7, developed  
20 larvae 11, mature larvae and prepupae 13, pupae 15 and adults 35. In the system 400, the entire insect life cycle may be managed, including pupating; hatching, eating, flying and/or crawling of adults; mating by adults; and egg laying (ovipositioning). Dedicated structures for ovipositioning and/or pupating and/or hatching from pupae may be provided (not shown).

For harvesting of mature larvae, prepupae and/or adults, various techniques  
25 may be used. For the larvae, e.g., urging and/or luring into a receptacle may be employed as described above, possibly assisted by shaking the larvae off the plant(s) 1. Hand- and/or machine-picking of mature larvae may also be employed. For adult insects, any suitable technique may be used such as luring the adults with pheromones and/or light and/or temperature into a catching device e.g. a fyke net, but also, in particular in case of flying  
30 adults, using vacuum suction. It should be noted that vacuum suction could also be used for harvesting larvae.

The system 400 is provided with an optional camera 37 serving for detecting at least one insect life parameter and at least one plant life parameter. The camera 37 may be

functionally connected to the controller 25 and/or to the light sources 21, 29 and their controllers 19, 27, and/or to other systems, possibly remote.

Fig. 7 indicates a method of cultivating insects with the system 400:

5 Step 7A: providing herbivorous and/or omnivorous insects in a container for confining the insects and providing plant material as feedstock for the insects in the form of one or more live plants in a plant growing medium and exposed to the insects.

10 Step 7B: detecting at least one insect life parameter of the insects and adjusting in at least part of the container at least one of the control parameters on the basis of the detected at least one insect life parameter for stimulating growth of the insects, the control parameter being selected from temperature, humidity, illumination, air composition, additional feedstock for at least part of the insects, amount of the plant material and composition of the plant growing medium.

15 Step 7C: detecting at least one plant life parameter of the at least one plant; and adjusting in at least part of the container at least one of the control parameters on the basis of the detected at least one plant life parameter, the control parameter being selected from temperature, humidity, illumination, air composition, additional feedstock for at least part of the insects, and composition in the plant growing medium.

20 Note that step 7C may be done in parallel to step 7B and/or in any other sequence, based on whether it is desired to control the at least one insect life parameter and/or the at least one plant life parameter. Steps 7B and/or 7C may be repeated and/or alternated such that growth and development of plural individuals of the insects are synchronised with each other. For example, lowering temperature may essentially halt development of (larvae of) most insect species and bright light may both improve plant growth and hinder insect development. Conversely, increasing temperature and adjusting an illumination level may increase insect development.

25 Step 7D: harvesting of insects in a desired development stage.

30 Step 7E: optional detecting at least one plant life parameter of the at least one plant; and adjusting in at least part of the container at least one of the control parameters on the basis of the detected at least one plant life parameter, for recuperation of the one or more plants.

At least parts of the sequence 7A-7E may be repeated one or more times.

Note that the method and system, in particular system 400, may be provided with additional and new plants if need be.

In operation, part of the control of the system might be interrupted and/or be manually controlled. E.g., by making use of the control parameters light and temperature, one might intermediately ‘freeze’ the larvae, e.g. halting growth and movement; harvest the adult larvae; and next return to operation, e.g. starting the life cycle of the remainder/new cycles again by providing conditions such as temperature and light conditions for promoting growth again.

In a highly automated system in which the growth cycles can be controlled with one or more of the control parameters, a programmable controller may be provided which may predict growth on the basis of historical data and/or detector signals and control the system for controlled production of an insect harvest abundance.

At least part of various embodiments, in particular control and/or detection may be implemented as a program product for use with a computer system, where the program(s) of the program product define functions of the embodiments (including the methods described herein). In one embodiment, the program(s) can be contained on a variety of non-transitory computer-readable storage media, where, as used herein, the expression “non-transitory computer readable storage media” comprises all computer-readable media, with the sole exception being a transitory, propagating signal. In another embodiment, the program(s) can be contained on a variety of transitory computer-readable storage media. Illustrative computer-readable storage media include, but are not limited to: (i) non-writable storage media (e.g., read-only memory devices within a computer such as CD-ROM disks readable by a CD-ROM drive, ROM chips or any type of solid-state non-volatile semiconductor memory) on which information is permanently stored; and (ii) writable storage media (e.g., flash memory, floppy disks within a diskette drive or hard-disk drive or any type of solid-state random-access semiconductor memory) on which alterable information is stored.

The disclosure is not restricted to the above described embodiments which can be varied in a number of ways within the scope of the claims. For instance, since insects are often used as (additional) feed for fish or animals (e.g. for poultry). The present concepts may be used as a front-end to e.g. a closed mixed farming model (combining horticulture, insect cultivation and aquaculture/agriculture). Further, a direct feed-in of larvae to e.g. a poultry feeding apparatus and/or an aquaculture basin might be provided.

Elements and aspects discussed for or in relation with a particular embodiment may be suitably combined with elements and aspects of other embodiments, unless explicitly stated otherwise.

## CLAIMS:

1. Method for cultivating insects, comprising
- providing herbivorous and/or omnivorous insects in a container for confining the insects, and providing plant material as feedstock for the insects by providing one or more live plants in a plant growing medium and exposing to the insects as the feedstock plant material; and
  - controlling in at least part of the container at least one first control parameter selected from temperature, humidity, illumination, air composition, additional feedstock for at least part of the insects, amount of the plant material and composition of at least part of the plant growing medium, for stimulating growth of the insects; and
  - controlling in at least part of the container at least one second of the control parameters for stimulating growth of the one or more plants;
- where the method comprises
- controlling in at least part of the container the at least one first of the control parameters for selectively stimulating growth of the insects in dependence on the growth of the one or more plants, or
  - controlling in at least part of the container the at least one second of the control parameters for selectively stimulating growth of the one or more plants in dependence on the growth of the insects.
2. Method according to claim 1, comprising at least one of
- detecting at least one insect life parameter of the insects and adjusting in at least part of the container the at least one first of the control parameters on the basis of the detected at least one insect life parameter; and
  - detecting at least one plant life parameter of the at least one plant and adjusting in at least part of the container the at least one second of the control parameters on the basis of the detected at least one plant life parameter.
3. Method according to any one of the preceding claims, comprising adjusting in at least part of the container the at least one first of the control parameters, for stimulating

synchronisation of growth and/or development of plural individuals of the insects with respect to each other.

4. Method according to any one of the preceding claims, comprising providing a  
5 light source and providing illumination by the light source in at least part of the container, and comprising controlling at least one property of the illumination selected from intensity and spectral power distribution, as a function of time and/or position in the part of the container.
- 10 5. Method according to any one of the preceding claims, wherein the insects comprise one or more of black soldier fly (*Hermetia Illucens*), cucumber beetle (*Diabrotica undecimpunctata*), five-spotted hawkmoth (*Manduca quinquemaculata*), butterfly and moths.
6. Method according to any of the preceding claims, wherein the at least one first  
15 of the control parameters and the at least one second of the control parameters are different control parameters.
7. Method according to any one of the preceding claims, comprising providing  
in, or at least connected to, the container, a receptacle for collecting at least one of larvae,  
20 prepupae and pupae.
8. Method according to claim 6, comprising controlling in at least part of the receptacle at least one of temperature, humidity, illumination, air composition.
- 25 9. System for cultivating insects according to the method of any one of the preceding claims, comprising  
a container for confining herbivorous and/or omnivorous insects, and  
one or more live plants in a plant growing medium wherein the live plants are arranged in the container to be exposed to the insects as feedstock for the insects, and  
30 a controller adapted to  
- control in at least part of the container at least one first control  
parameter selected from temperature, humidity, illumination, air composition, additional feedstock for at least part of the insects, amount of the plant material and composition of at least part of the plant growing medium, for stimulating growth of the insects; and

- control in at least part of the container at least one second of the control parameters for stimulating growth of the one or more plants; wherein the controller is adapted to

5 - control in at least part of the container the at least one first of the control parameters for selectively stimulating growth of the insects in dependence on the growth of the one or more plants, or

- control in at least part of the container the at least one second of the control parameters for selectively stimulating growth of the one or more plants in dependence on the growth of the insects.

10

10. System according to claim 9, comprising at least one detector for detecting in the at least part of the container at least one of a temperature, humidity, illumination, air composition, amount of the plant material and composition of at least part of the plant growing medium, the controller and the detector being coupled for controlling in the at least  
15 part of the container the at least one first or at least one second control parameter on the basis of one or more signals from the detector.

11. System according to any one of claims 9-10, comprising at least one detector for detecting in the at least part of the container at least one insect life parameter of the  
20 insects and/or at least one detector for detecting in the at least part of the container at least one plant life parameter of the one or more plants.

12. System according to any one of claims 9-11, comprising a light source for providing illumination by the light source in the at least part of the container,  
25 wherein the controller is functionally connected with the light source and is configured for controlling at least one of intensity and spectral power distribution of the illumination as a function of time and/or position in the part of the container.

13. System according to any one of the claims 9-12, wherein the at least one first  
30 of the control parameters and the at least one second of the control parameters are different control parameters.

14. System according to any one of claims 9-13, comprising in, or at least connected to, the container, a receptacle for collecting at least one of larvae, prepupae and pupae.
- 5 15. System according to claim 14, comprising a receptacle controller, at least part of the receptacle and the controller being connected and configured that at least part of the receptacle is controllable or controlled with respect to at least one of temperature, humidity, illumination, air composition.

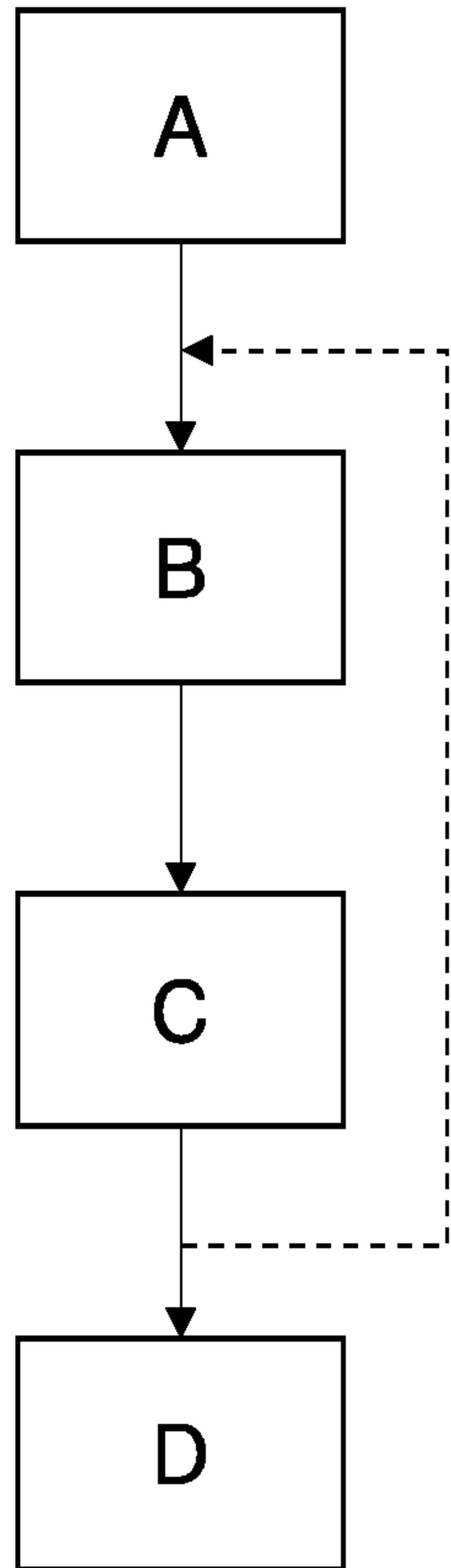

**Fig. 1**

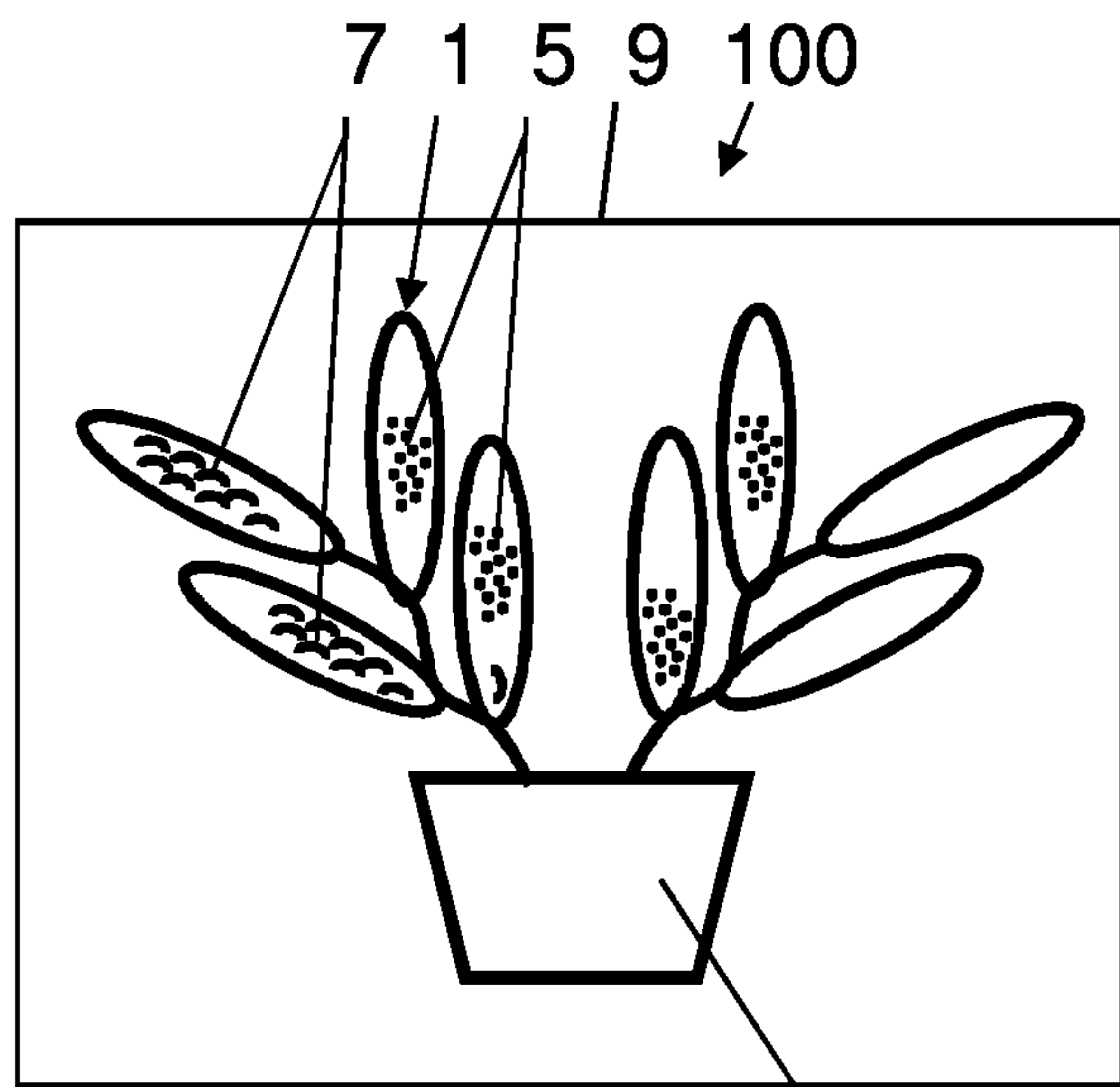

**Fig. 2**

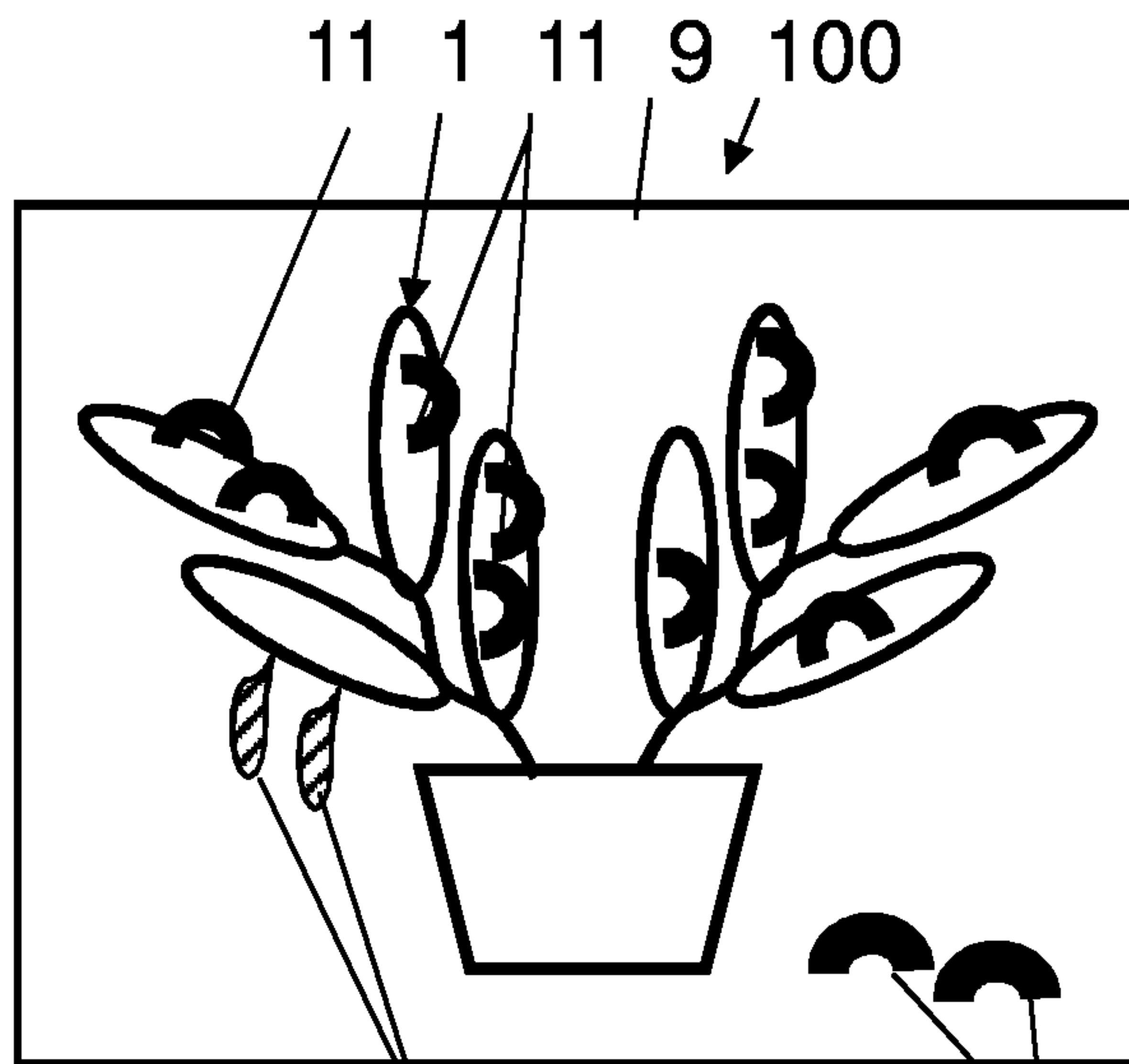

**Fig. 3**

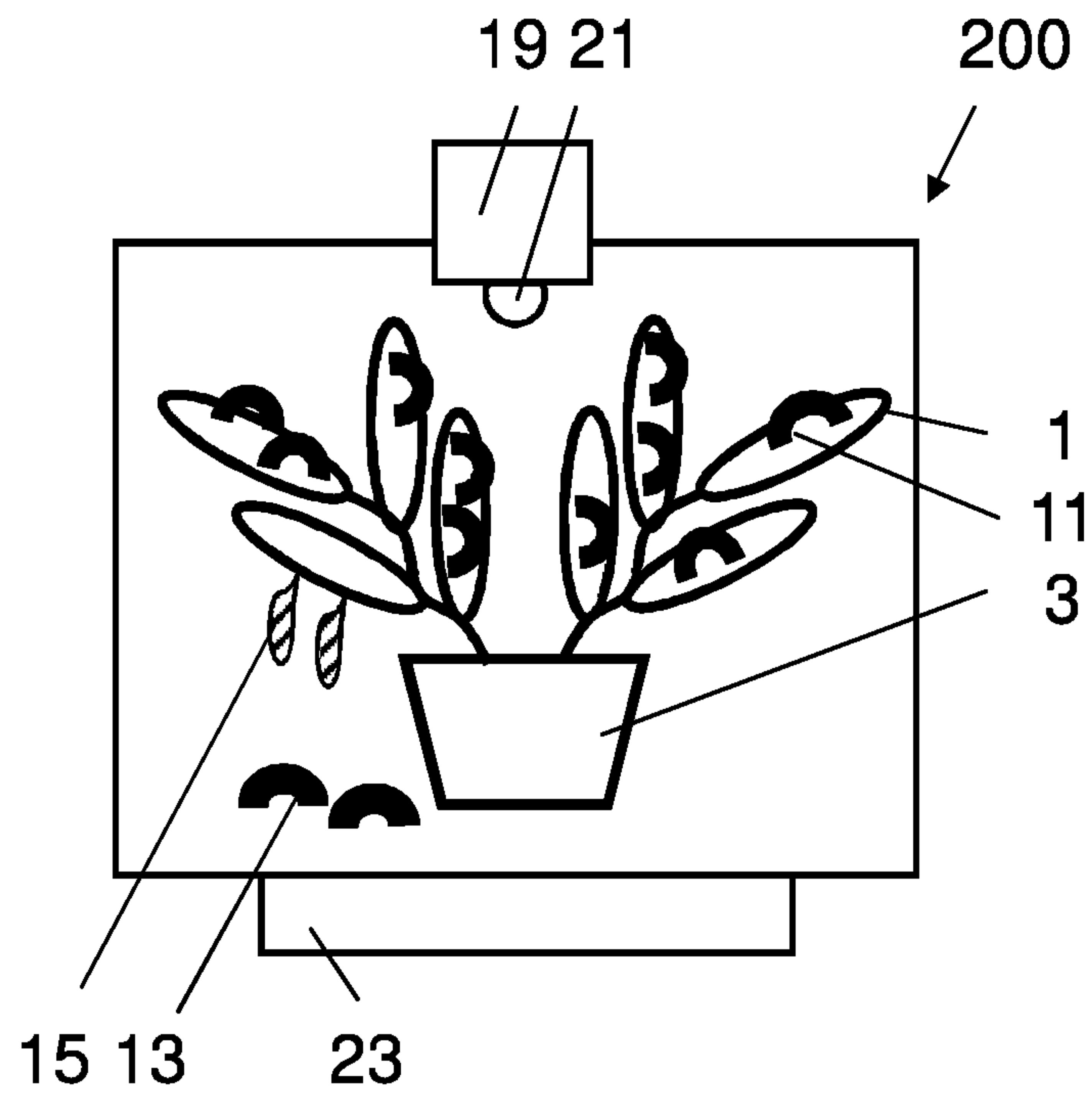

Fig. 4

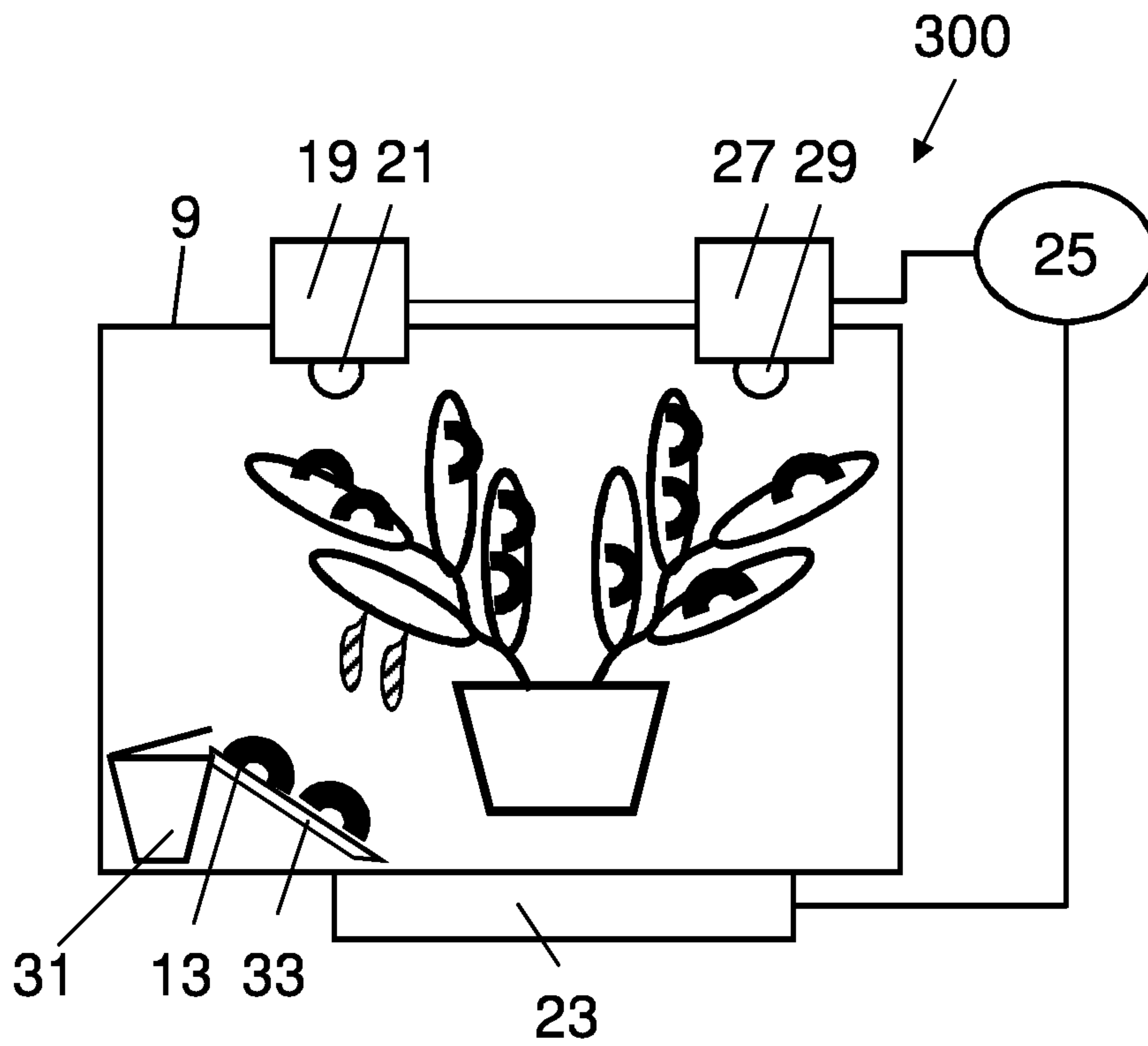
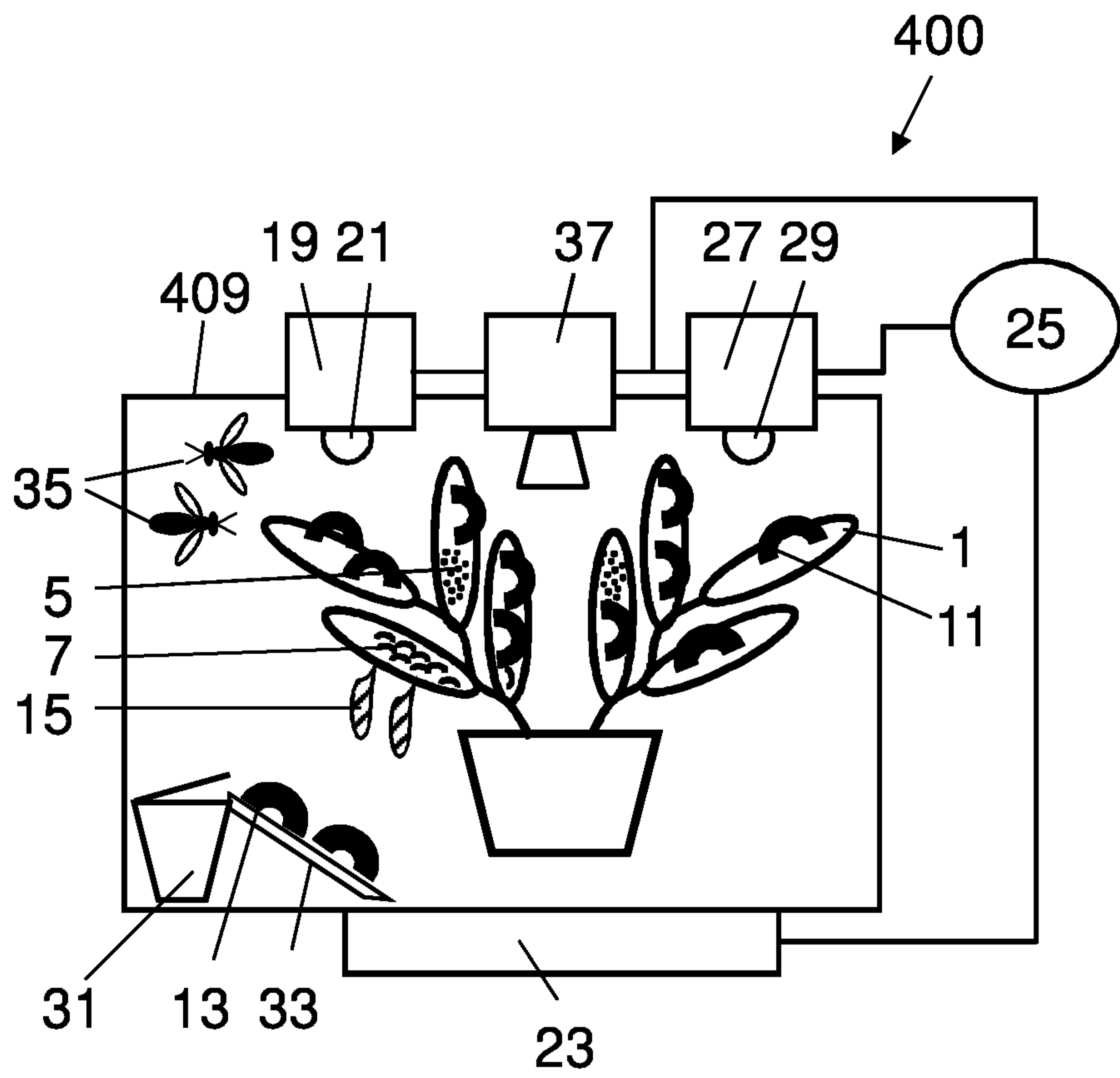
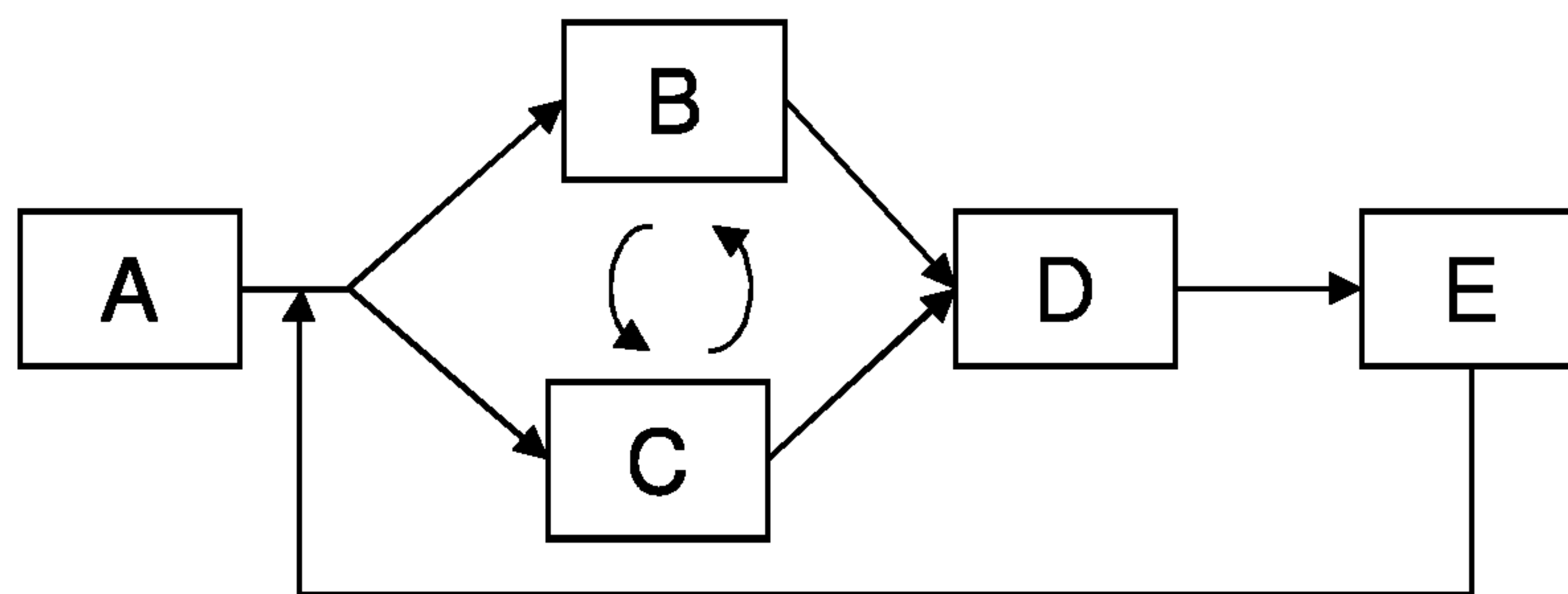

Fig. 5



**Fig. 6**



**Fig. 7**

**INTERNATIONAL SEARCH REPORT**

International application No PCT/EP2020/081027
---

**A. CLASSIFICATION OF SUBJECT MATTER**  
 INV. A01K67/033 A01G9/16  
 ADD.  
 According to International Patent Classification (IPC) or to both national classification and IPC

**B. FIELDS SEARCHED**  
 Minimum documentation searched (classification system followed by classification symbols)  
 A01K A01G  
 Documentation searched other than minimum documentation to the extent that such documents are included in the fields searched

Electronic data base consulted during the international search (name of data base and, where practicable, search terms used)  
 EPO-Internal, WPI Data

**C. DOCUMENTS CONSIDERED TO BE RELEVANT**

Category*	Citation of document, with indication, where appropriate, of the relevant passages	Relevant to claim No.
X	CN 102 523 974 A (UNIV NANJING AGRICULTURAL) 4 July 2012 (2012-07-04) cited in the application the whole document -----	1-15
X	KR 2010 0037482 A (LEE SANG HYUN [KR]) 9 April 2010 (2010-04-09) the whole document -----	1-15
X	KR 1999 0079066 A (REPUBLIC KOREA MAN RURAL DEV [KR]) 5 November 1999 (1999-11-05) the whole document -----	1-15
X	LU 100 403 B1 (ANXI HAIHONG BIOTECHNOLOGY CO LTD [CN]) 21 December 2017 (2017-12-21) the whole document -----	1-15

Further documents are listed in the continuation of Box C.  See patent family annex.

\* Special categories of cited documents :

"A" document defining the general state of the art which is not considered to be of particular relevance	"T" later document published after the international filing date or priority date and not in conflict with the application but cited to understand the principle or theory underlying the invention
"E" earlier application or patent but published on or after the international filing date	"X" document of particular relevance; the claimed invention cannot be considered novel or cannot be considered to involve an inventive step when the document is taken alone
"L" document which may throw doubts on priority claim(s) or which is cited to establish the publication date of another citation or other special reason (as specified)	"Y" document of particular relevance; the claimed invention cannot be considered to involve an inventive step when the document is combined with one or more other such documents, such combination being obvious to a person skilled in the art
"O" document referring to an oral disclosure, use, exhibition or other means	"&" document member of the same patent family
"P" document published prior to the international filing date but later than the priority date claimed	

Date of the actual completion of the international search  4 December 2020	Date of mailing of the international search report  17/12/2020
--	--

Name and mailing address of the ISA/ European Patent Office, P.B. 5818 Patentlaan 2 NL - 2280 HV Rijswijk Tel. (+31-70) 340-2040, Fax: (+31-70) 340-3016	Authorized officer  Batres Arnal, Lucía
--	---

# INTERNATIONAL SEARCH REPORT

Information on patent family members

International application No

PCT/EP2020/081027

Patent document cited in search report	Publication date	Patent family member(s)	Publication date
CN 102523974	A	04-07-2012	NONE
-----			
KR 20100037482	A	09-04-2010	NONE
-----			
KR 19990079066	A	05-11-1999	NONE
-----			
LU 100403	B1	21-12-2017	NONE
-----			